

APEM

4000 SERIES - POTENTIOMETER JOYSTICKS

TWO STANDARD MOUNTING OPTIONS LOW CURRENT DRAIN IP65 ABOVE PANEL

VARIETY OF POTENTIOMETER OPTIONS ROBUST, INDUSTRIAL, ALL METAL MECHANISM

AVAILABLE IN CLOSED & OPEN BODY VARIANTS INHERENTLY IMMUNE TO R.F.I.

OPTIONAL CENTRE-DETECT MICROSCHITCHING HIGH QUALITY POTENTIOMETERS



4000 SERIES - POTENTIOMETER JOYSTICKS

PRODUCT DESCRIPTION

GENERAL DESCRIPTION

The 4000 Series is a range of robust, industrial quality potentiometer joysticks. All 4000 Series share the same, all metal, mechanism to provide the finest performance and service life over a wide range of temperatures and loads. All 4000 Series employ high quality plastic film potentiometers, yielding a service life of many millions of cycles.

Whilst contactless joysticks such as the 9000 Series have replaced potentiometer joysticks in many applications, the 4000 Series continue to be popular owing to their ease of interfacing, wider operating voltage span, lower current drain and inherent immunity to RFI.

MECHANISM

Unlike most other products in its class the 4000 Series employs an all-metal mechanism, providing the finest feel. It delivers consistent return to centre performance over life, across a broad range of applications and operating environments. The 4000 Series is offered in two body styles; the more standard closed body type should be selected for those applications requiring gaiter option 5. The open frame variant may be specified for use with gaiter option 1, or in the case the joystick is specified with friction hold, or where space in the immediate vicinity of the joystick is very limited.

POTENTIOMETERS

The high quality plastic film potentiometers employed as standard in the 4000 Series have 340° tracks. With a shaft deflection angle of 55° (+/-27.5°), a typical 12V supply would therefore result in a full-scale nominal deflection from 5V to 7V, operating about a nominal 6V centre. The 4000 Series is available with alternative potentiometers, including the option of the 5K-55° track variant, providing rail-to-rail signal swings for applications where these are necessary and additional amplification is not practical.

Potentiometer option 2 is ideal for safety critical applications. Acting like two potentiometers in one, potentiometer option 2 provides two completely independent wiper signals, which may also be powered separately and yield nominally rail to rail outputs. The potentiometers on the 4000 Series are designed for use as a variable potential divider rather than a two pin variable resistor. Noise generated by the contact resistance of the wiper to the track dictates that for optimum performance the output signals should be fed into a load of greater than 100K.

Potentiometer option 9 is to special order only, and may be subject to longer than standard lead times.

GATING

Being a sub-panel mount joystick the panel cut-out may be used to limit the deflection of the joystick. The maximum allowable panel cutout dimensions are shown on the following page. Where some handles may be larger than the specified panel cut-out please refer to the Apem sales team. Subsequently the joystick may be supplied without the handle fitted, or with an additional mounting plate.

SPRINGING

As standard 4000 Series are offered sprung to centre. The standard spring force requires 1.3N (nominally) to off-centre the joystick. The 4000 Series may be specified with a lighter spring (1N), or a stronger spring (1.6N).

N.B. Forces quoted are subject to exact joystick configuration and are provided as a guide only.

Note: The company reserves the right to change specifications without notice.

4000 SERIES - POTENTIOMETER JOYSTICKS

PRODUCT CONFIGURATION

STANDARD OPTIONS

The 4000 Series is available with a range of standard options, to specify your joystick, simply choose one option from each column. An example is shown below.

4	R	2	1	2	S	1	E	5	5	00
SERIES	BODY	AXES	POTS	- 2 -	SPRING	- 1 -	HANDLE	BEZEL	GAITER	MODIFIER
4000 (4)	Closed (R) Open (P)	One (1) Two (2) Three (3)	10K 340° (1) 5K Dual Output (2) 5K 340° (5) 5K 55° (8) 5K 55°+CT (9)		Friction Hold (F) Strong (H) Standard (S) Weak (W)		Round (C) Cylindrical (D) Conical (E) Conical (G) Push Button Tactile (M) Push Button Soft Touch (N) Skirted (Q) Third Axis (R) Third Axis - Knurled (Y)	None (0) Square (3) Circular (5)	Internal (1) Standard (5)	None (00)

CABLE SPECIFICATION

Cable information may be subject to specification, please refer to Apem for details.

14/0.12 - Fourteen strands of 0.12mm diameter tinned annealed copper wire PVC insulated, to a nominal OD of 1mm	
Red : +Vcc for X & Y Axes	Black : 0V for X & Y Axes
Blue : X Axis Wiper	Yellow : Y Axis Wiper
Green : Centre Tap	
7/0.127 - Seven strands of 0.127mm diameter tinned copper wire ETFE insulated, to a nominal OD of 0.7mm	
Orange : Push Button	
Red : +Vcc for Z Axis	Blue : 0V for Z Axis
Green : Z Axis Wiper	
All 4000 Series are supplied with 150mm of twisted cable harness, with tinned ends.	
Connectors fitted upon request.	

TECHNICAL SPECIFICATION

All parameters and dimensions shown maybe subject to specification, please refer to Apem for details.

Life Cycles : >5 Million Operations	Lever Travel : +/-27.5 Degrees
Lever Material : Stainless Steel	Body Material : Glass Filled ABS or Steel
Knob Material : Nylon or Aluminium	Gaiter Material : Neoprene
Pivot Blocks : HE30 Alloy	Other Materials : Brass
Temperature Range : -20°C to +55°C	Resistance Tolerance : +/-20%
Linearity : +/-2%	Output Smoothness : 0.1% max
Power Rating : 1W at 70°C - Derate to 0W at 125°C	Insulation Resistance : 1000M Ohms, 500V DC
Preferred Load : >100K	Potentiometer Alignment : To Centre of Track (+/-1%)
Weight : 110 Grams	Above Panel Seal : IP65

4000 SERIES - POTENTIOMETER JOYSTICKS

USEFUL DIMENSIONS

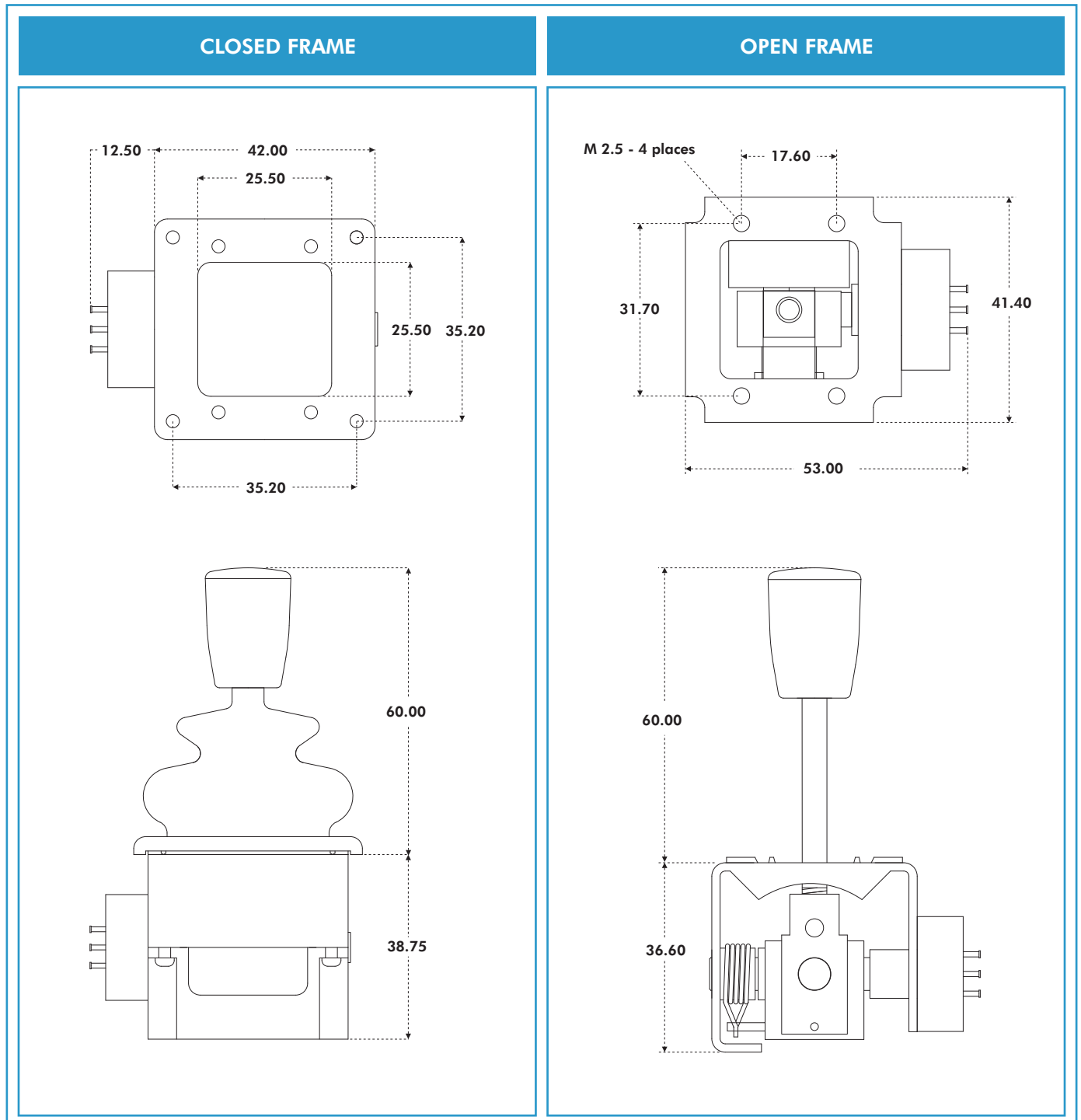

Note: The dimensions shown are for a generic two axes 4000 Series open frame with the E type handle, and a generic two axes 4000 Series closed frame also with the two axes E type handle. For specific dimensions of this or any other configuration please refer to Apem.

4000 SERIES - POTENTIOMETER JOYSTICKS

USEFUL DIMENSIONS

OPEN FRAME - PANEL CUT-OUT AND MOUNTING INSTALLATION

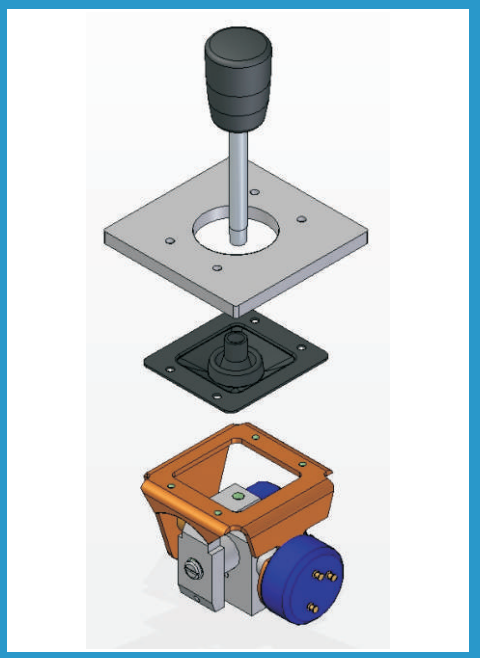

MOUNTING CUT-OUT

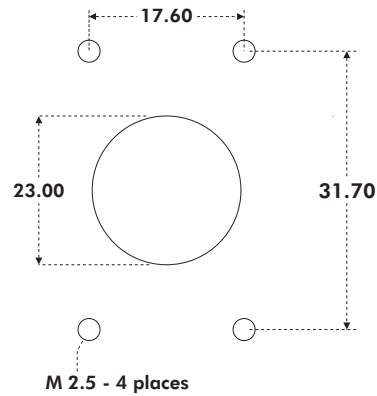

The joystick mounts from beneath the panel and the gaiter is trapped between the joystick and the panel. No bezel is necessary for this installation, since the panel acts as the bezel. The frame has M2.5 tapped holes and as such M2.5 machine screws are recommended for this mounting.

CLOSED FRAME - PANEL CUT-OUT AND MOUNTING INSTALLATION

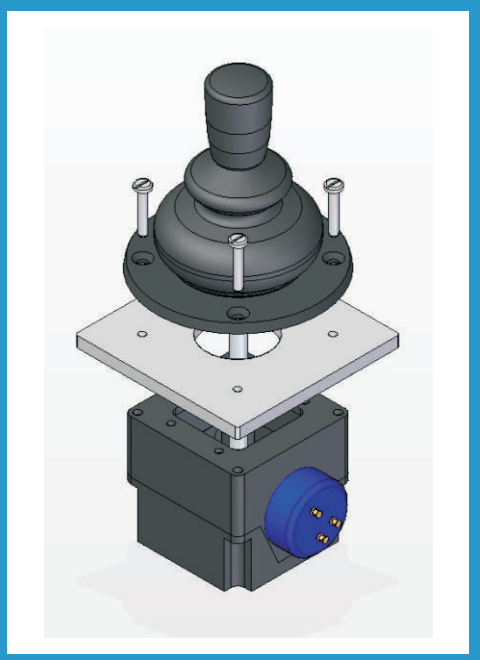

MOUNTING CUT-OUT

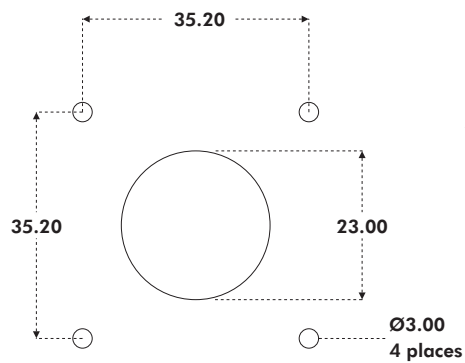

The body of the joystick is mounted from beneath the panel. The gaiter is passed through the panel cut-out and is held onto the front face of the panel by the mounting bezel. The square bezel has a gloss finish and is designed for use with No.4 x 3/8" pan head self tapping screws whereas the circular bezel has a matt finish and is designed for countersunk screws.

Note: During the mounting process, great care should be taken not to damage the gaiter. All panel cut-outs should be free from sharp edges and swarf that may damage the gaiter.

HANDLE SELECTION GUIDE

HANDLE C

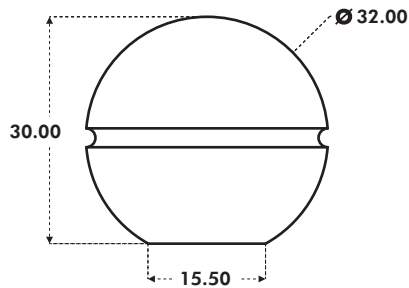

The conventional choice for power chairs.

MATERIAL: Phenolic

FINISH: Gloss

STANDARD COLOUR: Black

OTHER COLOURS: Upon request

AVAILABLE: 1000, 4000, 8000 and 9000 Series

HANDLE D

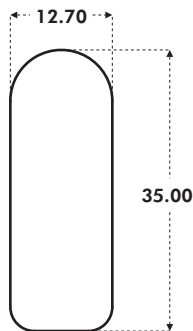

A tall cylindrical handle, with an anodised aluminium finish.

MATERIAL: Aluminium

FINISH: Anodised

STANDARD COLOUR: Black

OTHER COLOURS: Not available

AVAILABLE: 1000, 4000, 8000 and 9000 Series

HANDLE E

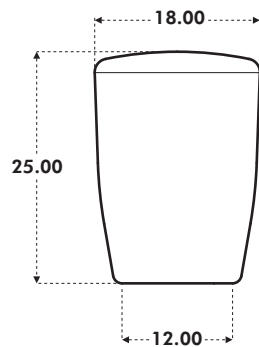

A mid-size conical handle with a modern look and feel.

MATERIAL: Nylon

FINISH: Matt

STANDARD COLOUR: Black

OTHER COLOURS: Upon request

AVAILABLE: 4000, 8000 and 9000 Series

HANDLE F

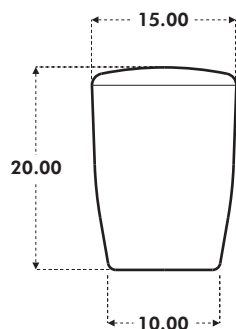

The smallest conical handle for that feel of precision.

MATERIAL: Nylon

FINISH: Matt

STANDARD COLOUR: Black

OTHER COLOURS: Upon request

AVAILABLE: 1000 and 5000 Series

Note: The drawings above are not to scale and all dimensions shown are in millimeters.
Note: Different colour variants may be subject to minimum order quantities.