

AUTOMATIC VOLTAGE SWITCH (SMPS < 300W)

CONTROLLER

- 50/60Hz FULL COMPATIBILITY
- INTEGRATED VOLTAGE REGULATOR
- TRIGGERING PULSE TRAIN OF THE TRIAC
- PARASITIC FILTER
- LOW POWER CONSUMPTION

TRIAC

- HIGH EFFICIENCY AND SAFETY SWITCHING
- UNINSULATED PACKAGE : AVS10CB
- INSULATED PACKAGE 2500V(RMS) : AVS10CBI
- $V_{DRM} = \pm 600V$
- $I_T(RMS) : 8A$

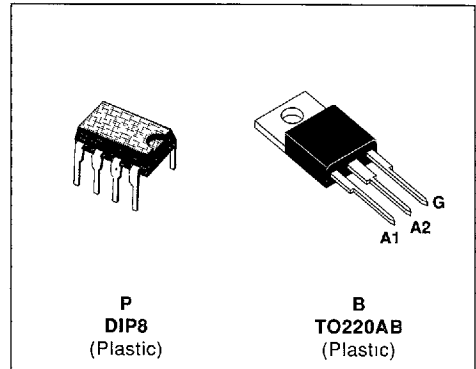

DESCRIPTION

The AVS10 kit is an automatic mains selector (110/220V AC) to be used in SMPS < 300 W. It is composed of 2 devices :

- The **Controller** is optimized for low consumption and high security triggering of the triac. When connected to V_{SS} , the **mode** input activates an additional **option**. If the main power drops from 220V to 110V, the triac control remains locked to the 220V mode and avoids any high voltage spike when the voltage is restored to 220V. When connected to V_{DD} , the **mode** input deactivates this **option**.
- The **TRIAC** is specially designed for this application. An optimization between sensitivity and dynamic parameters of the triac gate highly reduces the losses of supply resistor and allows excellent immunity against disturbances.

PIN CONNECTION

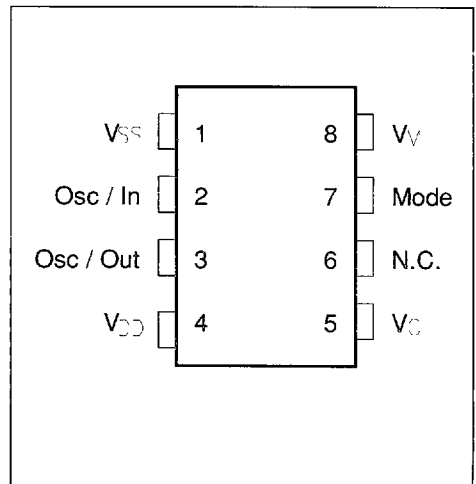

BLOCK DIAGRAM

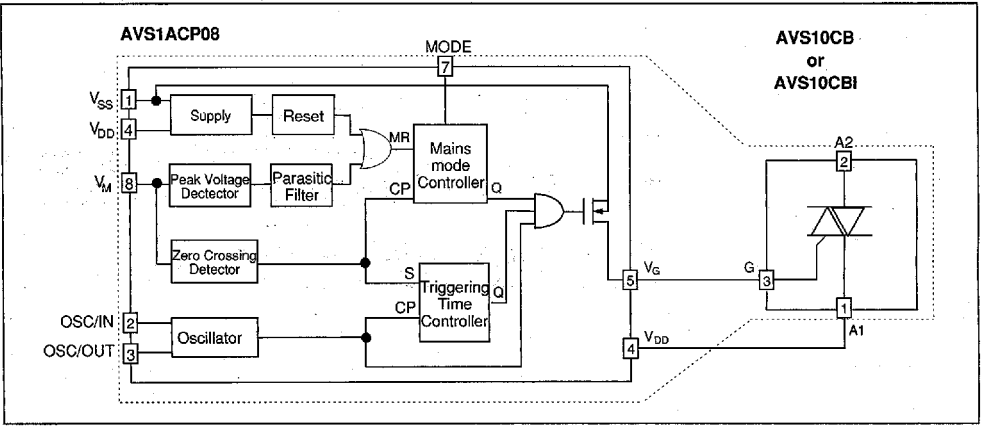

ABSOLUTE MAXIMUM RATINGS

CONTROLLER AVS1ACP08

Symbol	Parameter	Value		Unit
		Min.	Max.	
V _{SS}	Supply voltage	- 12	0.5	V
V _I / V _O	I / O voltage	V _{SS} - 0.5	0.5	V
I _I / I _O	I / O current	- 40	+ 40	mA
T _{stg}	Storage Temperature	- 60	+ 150	°C
T _{oper}	Operating Temperature code " C "	0	+ 70	°C

TRIAC AVS10CB / AVS10CBI T_j = +25°C (unless otherwise specified)

Symbol	Parameter		Value	Unit
V _{DRM}	Repetitive peak off-state voltage (2)		± 600	V
I _{T(RMS)}	RMS on-state current (360° conduction angle)	AVS10CB T _C = 80°C	8	A
		AVS10CBI T _C = 70°C		
I _{TSM}	Non repetitive surge peak on-state current (T _j initial = 25°C)	t = 8.3ms	85	A
		t = 10ms	80	
I _{2t}	I _{2t} value	t = 10ms	32	A ² s
di/dt	Critical rate of rise of on-state current (1)	Repetitive F = 50Hz	20	A/μs
		Non Repetitive	100	
dv/dt *	Linear slope up to 0.67 V _{DRM} Gate open	T _j = 110°C	50	V/μs
T _{stg} T _j	Storage Temperature Operating Junction Temperature		- 40 + 150 0 + 110	°C

(1) Gate supply : I_G = 100mA — di/dt = 1A/μs * For either polarity of electrode A2 voltage with reference to electrode A1
 (2) T_j = 110°C

THERMAL RESISTANCES

TRIAC AVS10CB / AVS10CBI

Symbol	Parameter		Value	Unit
Rth (j-a)	Junction-to-ambient		60	°C/W
Rth (j-c) DC	Junction-to-case for DC	AVS10CB	3.5	°C/W
		AVS10CBI	4.4	
Rth (j-c) AC	Junction-to-case for 360° conduction angle (F = 50Hz)	AVS10CB	2.6	°C/W
		AVS10CBI	3.3	

DC GENERAL ELECTRICAL CHARACTERISTICS

TRIAC AVS10CB / AVS10CBI

Symbol	Parameter		Value		Unit	
			Min.	Max.		
V _{GD}	V _D = V _{DRM} R _L = 3.3kΩ	Pulse duration > 20μs	T _J = 110°C	0.2	V	
V _{TM} *	I _{TM} = 11A	t _p = 10ms	T _J = 25°C		1.75	V
I _{DRM} *	V _{DRM} rated	Gate open	T _J = 25°C		10	μA
			T _J = 110°C		500	

* For either polarity of electrode A2 voltage with reference to electrode A1.

Fig. 1 : Maximum RMS power dissipation versus RMS on-state current ($F = 60\text{Hz}$).
(Curves are cut off by $(di/dt)c$ limitation)

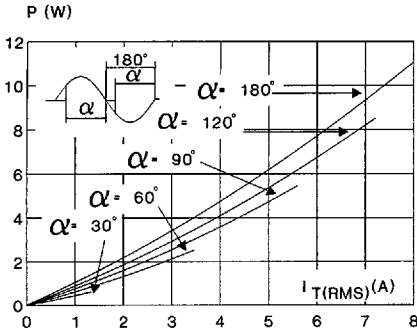

Fig. 2 : Correlation between maximum mean power dissipation and maximum allowable temperatures (T_{amb} and T_{case}) for different thermal resistances heatsink + contact (AVS10CB).

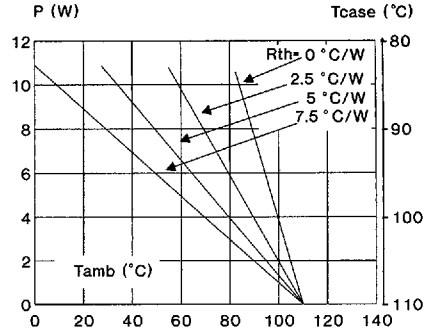

Fig. 3 : Correlation between maximum mean power dissipation and maximum allowable temperatures (T_{amb} and T_{case}) for different thermal resistances heatsink + contact (AVS10CB).

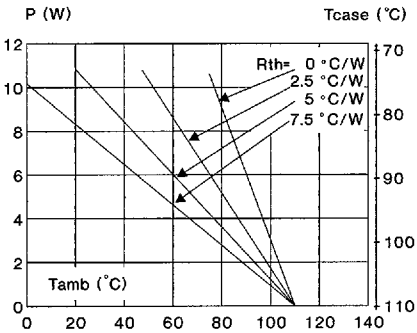

Fig. 4 : Non repetitive surge peak on-state current for a sinusoidal pulse with width : $t \leq 10\text{ms}$, and corresponding value of I^2t .

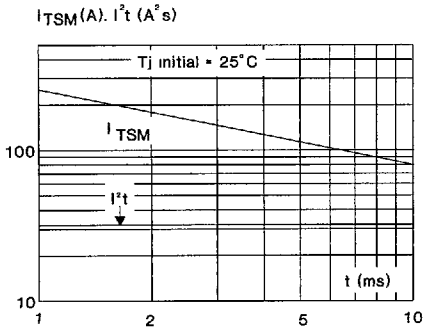
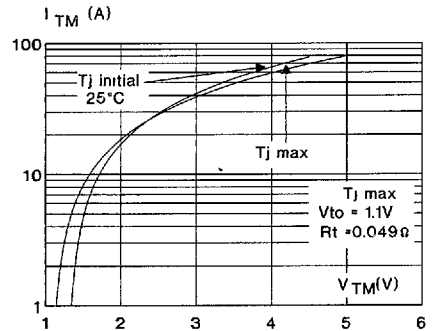

Fig. 5 : On-state characteristics (maximum values).



DC GENERAL ELECTRICAL CHARACTERISTICS (continued)

CONTROLLER AVS1ACP08 $T_{oper} = 25^{\circ}C$ (unless otherwise specified)

Symbol	Parameter	Value			Unit
		Min	Typ	Max	
VSS (pin 1) (Vreg)	Shunt regulator	- 10	- 9	- 8	V
ISS (pin 1) (Vreg) (@ VSS = 9V)	Supply current	0.4		30	mA
ISS (pin 1) (@ triac gate non connected)	Quiescent current			0.7	mA
f (pin 3) (@ R = 91kΩ) (C = 100pF)	Oscillator frequency	42	44	46	kHz
VM (pin 8) Vth (3)	Peak voltage of detection high-threshold	4.08	4.25	4.42	V
VM (pin 8) Vh (3)	Peak voltage of detection hysteresis	0.370	0.4	0.420	V
(1) VM (pin 8) Vth (3)	Zero-crossing detection high-threshold	95	110	125	mV
VM (pin 8) Vh (3)	Zero-crossing detection hysteresis	27	50	80	mV
(2) Vrazht (4)	Power-on-reset activation threshold		Vreg x 0.89		V
(2) Vrazilt (4)	Power-down-reset activation threshold	3		6.5	V
Mode (pin 7)	VIL (4) VIH (4)	0.7 Vreg		0.3 Vreg	V
VG (pin 5)	VOL (IVG = 25mA) Leakage current (VG = VDD)			650 + 10	mV μA

NOTES :

- (1) : This value gives a typical noise immunity on the zero-crossing detection of $110mV \times 1018/18 = 6.20V$ on the main supply
- (2) : See following diagram
- (3) : Voltage referred to VSS
- (4) : Voltage referred to VDD

POWER-ON AND POWER-OFF RESET BEHAVIOUR

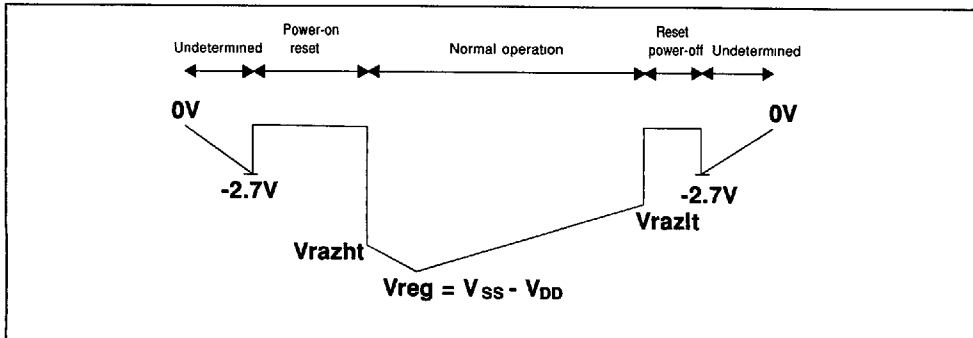

TYPICAL APPLICATION

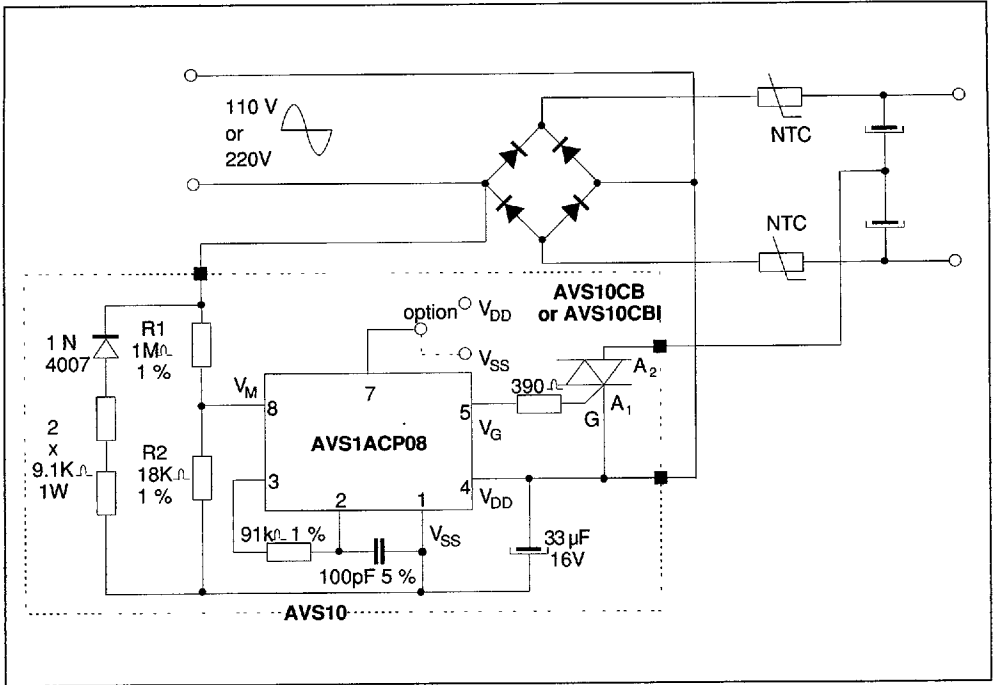

ORDERING INFORMATION

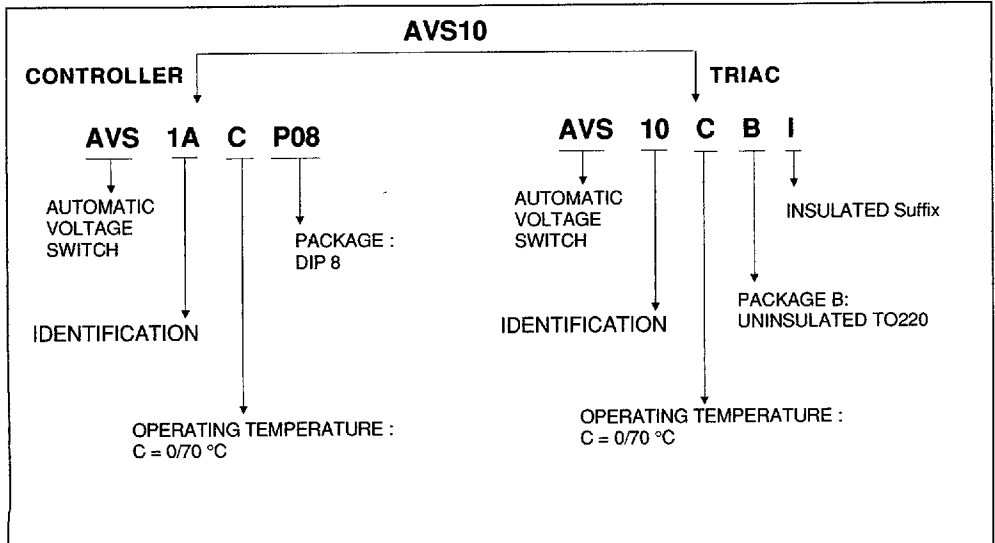

PACKAGE MECHANICAL DATA

8 PINS - PLASTIC DIP

CONTROLLER

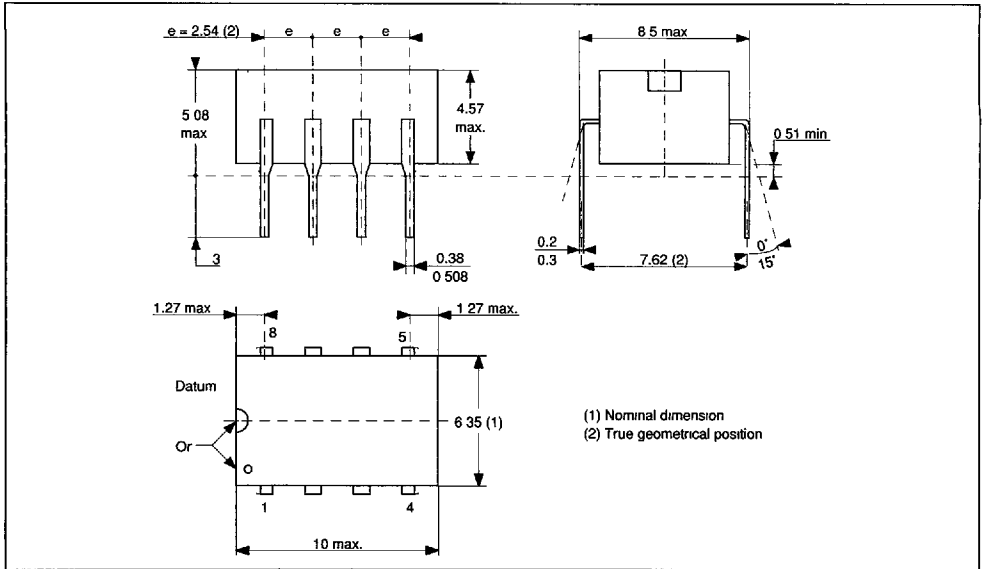

TO220AB (Plastic) (in millimeters)

TRIAC

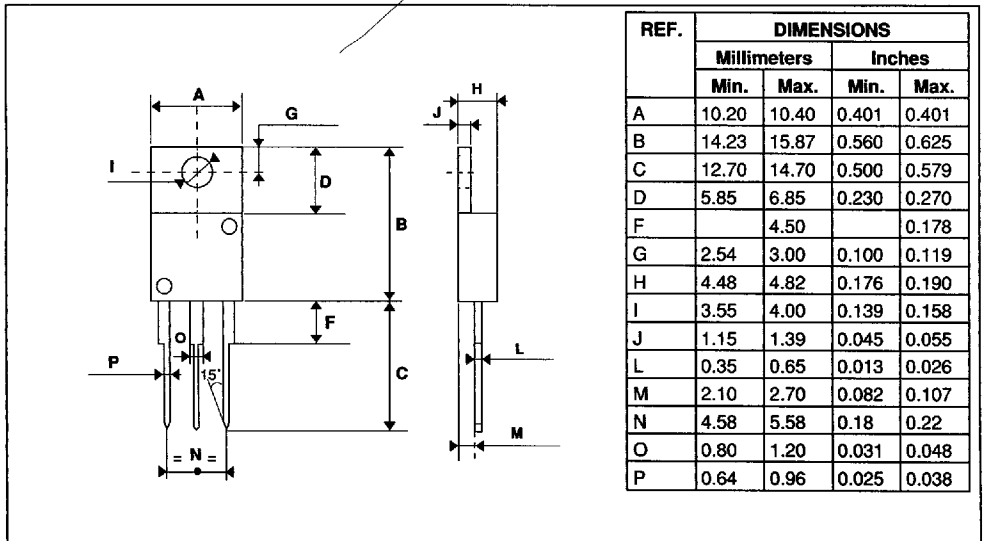

Cooling method : by conduction (method C)

Marking : Type number

Weight : 2.3 g

Polarity : N A

Stud torque : N A