

STRAIGHT INSULATED SQUARE FLANGE JACK

R141.256.000

CLAMP TYPE - CABLE 5/50 S

Series : BNC

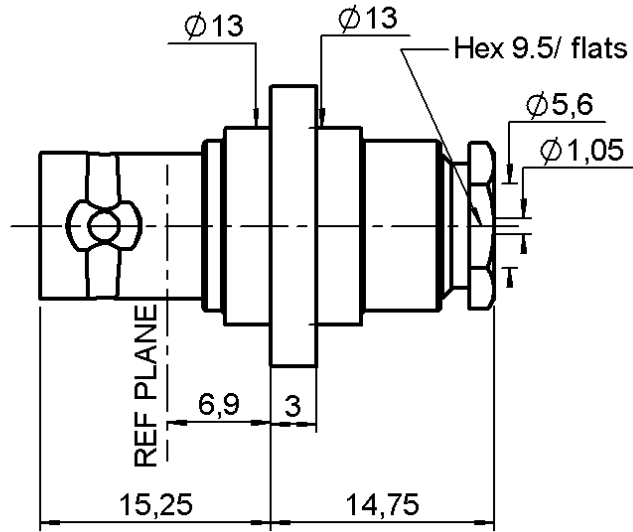
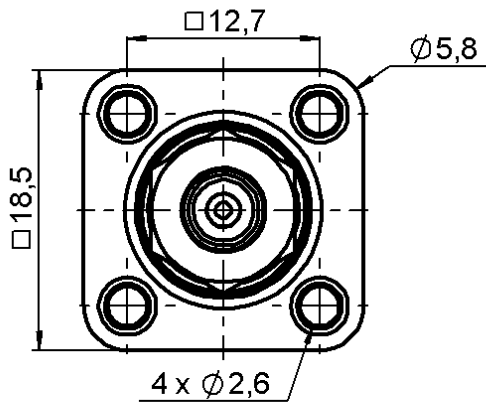

PANEL CUT OUT

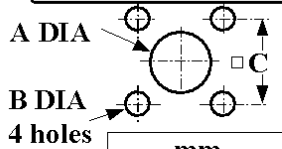

	mm	
	Maxi	mini
A	13.3	13.2
B	2.7	2.6
C	12.75	12.7

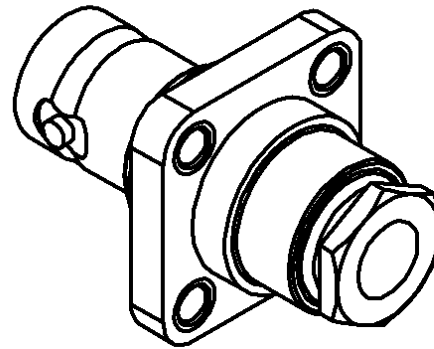
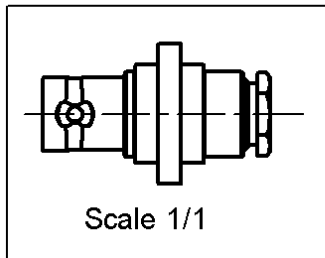

All dimensions are in mm.



COMPONENTS	MATERIALS	PLATINGS (µm)
BODY	BRASS	NICKEL 2
CENTER CONTACT	BERYLLIUM COPPER	GOLD 0.5 OVER NICKEL 2
OUTER CONTACT	-	-
INSULATOR	PTFE	-
GASKET	SILICONE RUBBER	-
OTHERS PARTS	-	-
.	-	-
.	-	-
.	-	-

Issue : 0210 R

In the effort to improve our products, we reserve the right to make changes judged to be necessary.



STRAIGHT INSULATED SQUARE FLANGE JACK

R141.256.000

CLAMP TYPE - CABLE 5/50 S

Series : **BNC**

PACKAGING

Standard	Unit	Other
100	'W' option	Contact us

SPECIFICATION

ELECTRICAL CHARACTERISTICS

Impedance		50	Ω
Frequency		0-4	GHz
VSWR	1.2 +	0.000	x F(GHz) Maxi
Insertion loss		0.115	\sqrt{F} (GHz) dB Maxi
RF leakage	- (57	- F(GHz)) dB Maxi
Voltage rating		500	Veff Maxi
Dielectric withstanding voltage		1500	Veff mini
Insulation resistance		5000	M Ω mini

CABLE ASSEMBLY

Stripping	a	b	c	d	e	f
mm	7.00	4.00	0.00	0.00	0.00	0.00

Assembly instruction : **CLAMP 03**

Recommended cable(s)
 RG 141
 RG 58
 KX 15

Cable retention
 - pull off **180** N mini
 - torque **NA** N.cm

MECHANICAL CHARACTERISTICS

Center contact retention			
Axial force – Mating end		NA	N mini
Axial force – Opposite end		NA	N mini
Torque		NA	N.cm mini

TOOLING

Part Number	Description	Hexagon
.	.	.

Recommended torque			
Mating		NA	N.cm
Panel nut		NA	N.cm
Clamp nut		150	N.cm
A/F clamp nut		9.500	mm

Mating life		500	Cycles mini
Weight		16.000	g

OTHERS CHARACTERISTICS

-

ENVIRONMENTAL

Operating temperature		-65/+165	$^{\circ}$ C
Hermetic seal		NA	Atm.cm3/s
Panel leakage		NA	

Issue : **0210 R**

In the effort to improve our products, we reserve the right to make changes judged to be necessary.

