

PART NUMBER	LED COLOR
595-2101-002F	RED
595-2101-007F	
595-2101-013F	
595-2201-002F	HI. INTENSITY GREEN
595-2201-007F	
595-2201-013F	
595-2301-002F	GREEN
595-2301-007F	
595-2301-013F	
595-2401-002F	YELLOW
595-2401-007F	
595-2401-013F	
595-2501-002F	ORANGE
595-2501-007F	
595-2501-013F	
595-2701-002F	AlInGaP YELLOW
595-2701-007F	
595-2701-013F	

OPERATING CHARACTERISTICS AT 25°C AMBIENT						
CHARACTERISTICS		MIN	TYP	MAX	UNITS	TEST CONDITIONS
LUMINOUS INTENSITY	RED		25.0		mcd	I _f = 20 mA
	GREEN		11.0			
	YELLOW		9.0			
	ORANGE		9.0			
FORWARD VOLTAGE	RED		1.7	2.0	V	I _f = 20 mA
	GREEN		2.1	2.5		
	YELLOW		2.2	2.5		
	ORANGE		2.2	2.5		
REVERSE VOLTAGE	RED	4			V	I _r = 100 µA
	GREEN	4				
	YELLOW	4				
	ORANGE	4				
PEAK WAVELENGTH	RED		660		nm	
	GREEN		560			
	YELLOW		580			
	ORANGE		605			

OPERATING CHARACTERISTICS AT 25°C AMBIENT						
CHARACTERISTICS		MIN	TYP	MAX	UNITS	TEST CONDITIONS
LUMINOUS INTENSITY	HI. INT. GREEN		8.5		mcd	I _f = 10 mA
	AlInGaP YELLOW		41.0			
FORWARD VOLTAGE	HI. INT. GREEN		2.2	2.6	V	I _f = 20 mA
	AlInGaP YELLOW		2.02	2.4		
REVERSE CURRENT	HI. INT. GREEN			100	µA	V _r = 5 V
	AlInGaP YELLOW			100		
PEAK WAVELENGTH	HI. INT. GREEN		566		nm	
	AlInGaP YELLOW		592			

ABSOLUTE MAXIMUM RATING AT 25°C AMBIENT			
			UNITS
POWER DISSIPATION	HI. INT. GREEN	65	mW
	AlInGaP YELLOW	81	
DERATE LINEARLY FROM 75°C (* FROM 55°C)	HI. INT. GREEN	0.75	mW/°C
	AlInGaP YELLOW	0.58 *	
CONTINUOUS FORWARD CURRENT	HI. INT. GREEN	25	mA
	AlInGaP YELLOW	30	
OPERATING TEMPERATURE	ALL	-30 TO 85	°C
STORAGE TEMPERATURE	ALL	-40 TO 100	°C
INFRARED REFLOW SOLDERING	ALL	240°C FOR 10 SEC	

ABSOLUTE MAXIMUM RATING AT 25°C AMBIENT			
			UNITS
POWER DISSIPATION	RED	60	mW
	GREEN	75	
	YELLOW	75	
	ORANGE	75	
DERATE LINEARLY FROM 25°C	RED, GRN, YEL	0.42	mW/°C
CONTINUOUS FORWARD CURRENT	RED, GRN, YEL, ORANGE	30	mA
PEAK FORWARD CURRENT (1/10 DUTY CYCLE, 0.1 ms PULSE WIDTH)	RED, GRN, YEL, ORANGE	70	mA
OPERATING TEMPERATURE	RED, GRN, YEL, ORANGE	-30 TO +85	°C
STORAGE TEMPERATURE	RED, GRN, YEL	-30 TO 80	°C
	ORANGE	-40 TO +100	
INFRARED REFLOW SOLDERING	RED, GRN, YEL	235°C FOR 15 SEC	
VAPOR PHASE SOLDERING	RED, GRN, YEL	215°C FOR 3 MIN	

REV	ECN NO	REVISIONS	DRN	CKD	APP	DATE
A	---	NEW RELEASE	TWC			

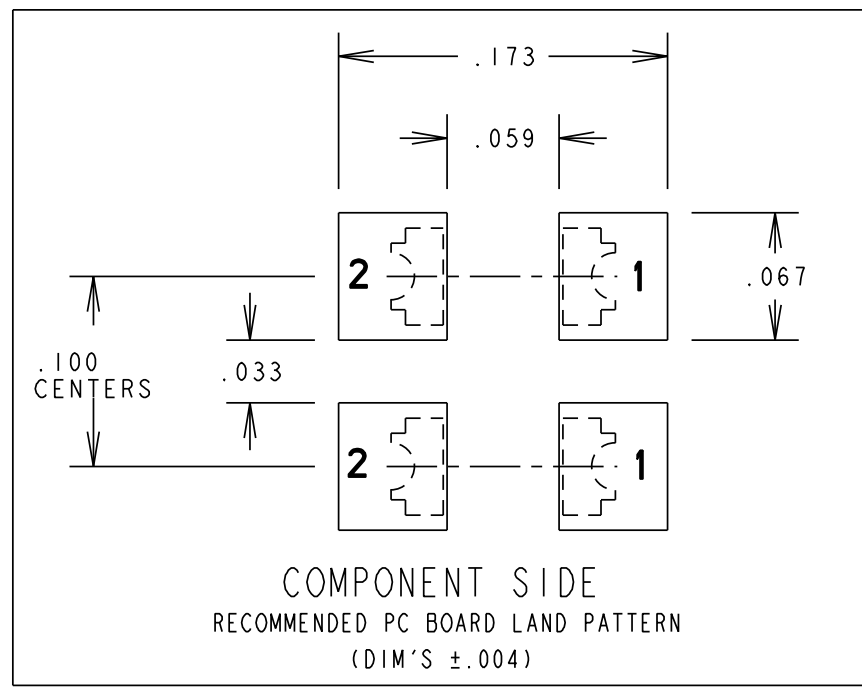
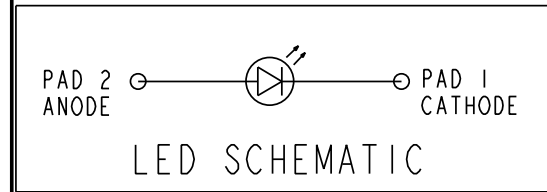

NOTES :

- MILLIMETER DIMENSIONS SHOWN FOR REFERENCE ONLY.
- PAD NUMBERS ARE FOR REFERENCE ONLY. DESIGNATION NON-EXISTENT ON PART.
- STORAGE CONDITIONS FOR TAPED PRODUCT: RE-TAPING MAY BE NECESSARY FOR PRODUCTS STORED MORE THAN TWELVE MONTHS.
- ORDER QUANTITY IS LED ASSEMBLIES, NOT REELS.
- ...002 SUFFIX MEANS PARTS ARE PACKED ON A 20 pc SAMPLE STRIP.
- ...007 SUFFIX MEANS PARTS ARE PACKED ON A 7 INCH REEL, 600 pcs/REEL.
- ...013 SUFFIX MEANS PARTS ARE PACKED ON A 13 INCH REEL, 2300 pcs/REEL.
- DIALIGHT PART NUMBERS =
595-2x01-002F, 595-2x01-007F, 595-2x01-013F.
- PLACE MOISTURE-SENSITIVE LEVEL "2a" LABEL ON 595-2201-007F, 595-2201-013F, 595-2701-007F, 595-2701-013F. LEVEL "4" LABEL ON 595-2101-007F, 595-2101-013F, 595-2301-007F, 595-2301-013F, 595-2401-007F, 595-2401-013F, 595-2501-007F, 595-2501-013F. VACUUM SEAL BAG.
- PACKAGING ONE HUMIDITY INDICATOR CARD(9100-999-0662-99) PER BAG.
- PER LENS INSPECTION PROCEDURE 01-225 THIS AREA CAN HAVE PORTIONS MISSING OF UP TO 50%. NON-CRITICAL AREA BELOW LENS.

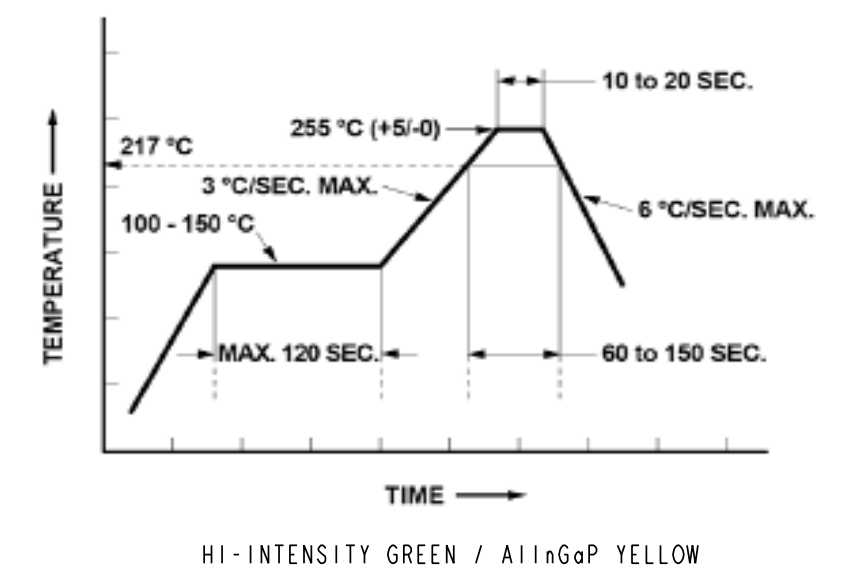
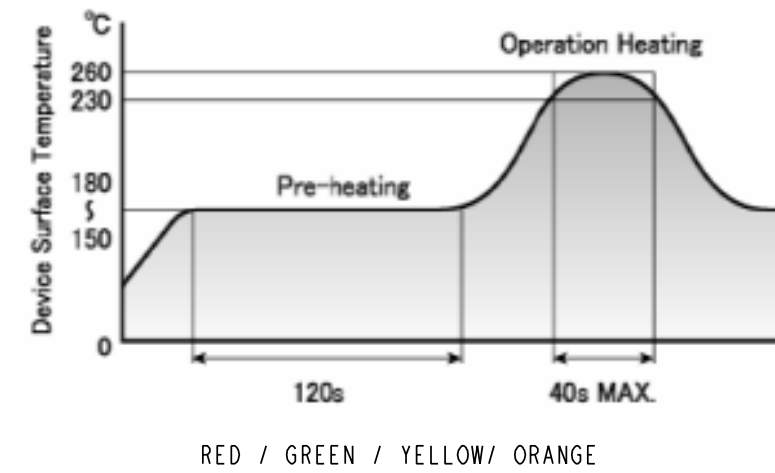
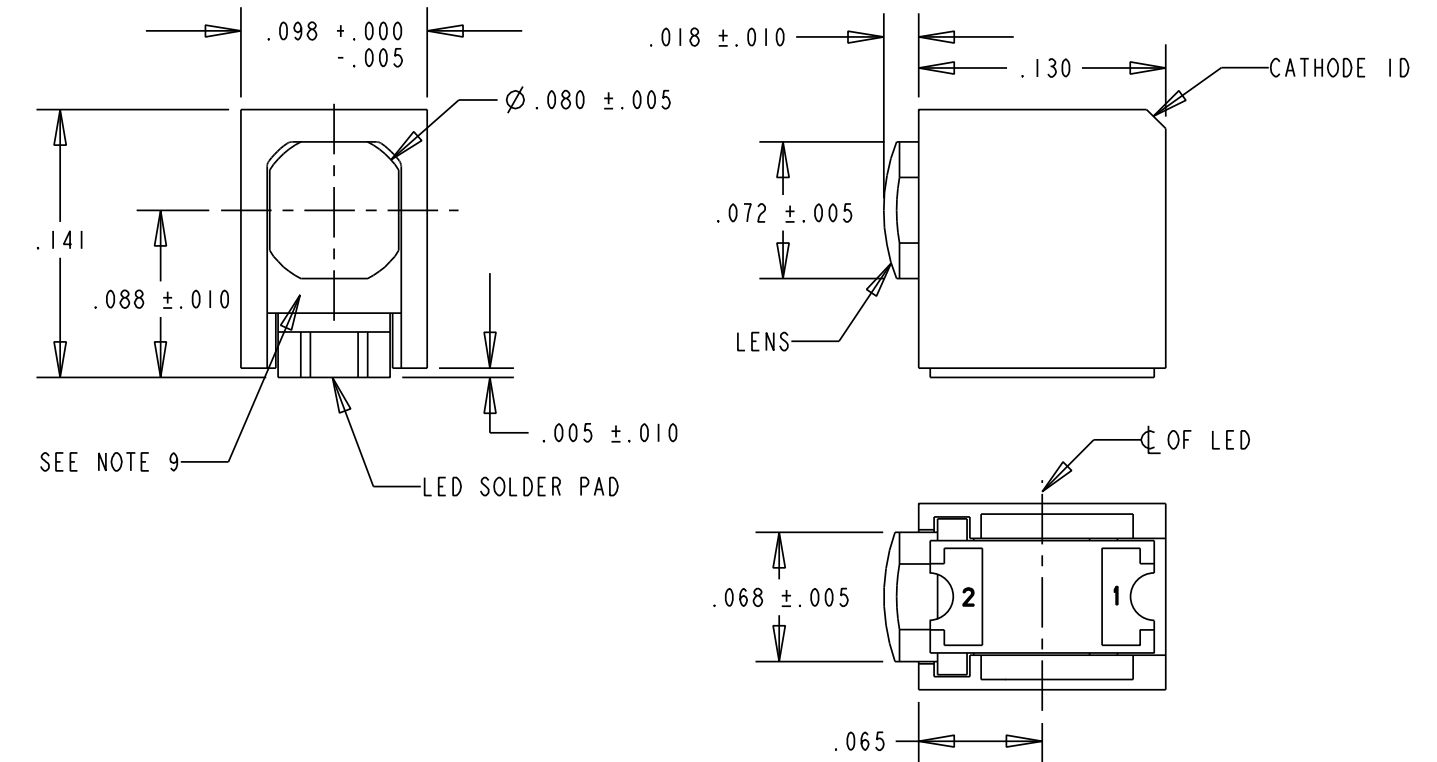

TAPING SPECIFICATION

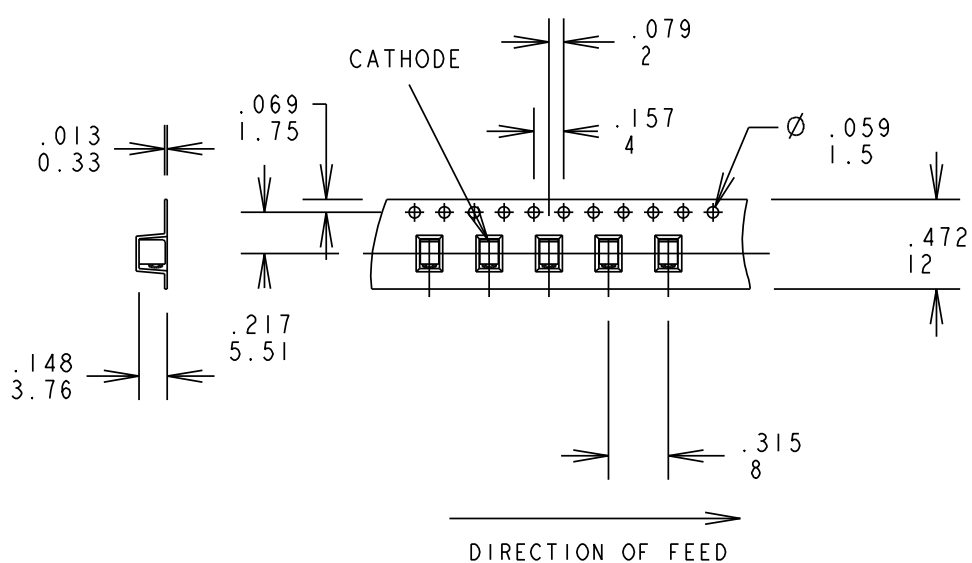

TOLERANCE: .004 UNLESS OTHERWISE SPECIFIED
MILLIMETER DIMENSIONS SHOWN FOR REFERENCE ONLY

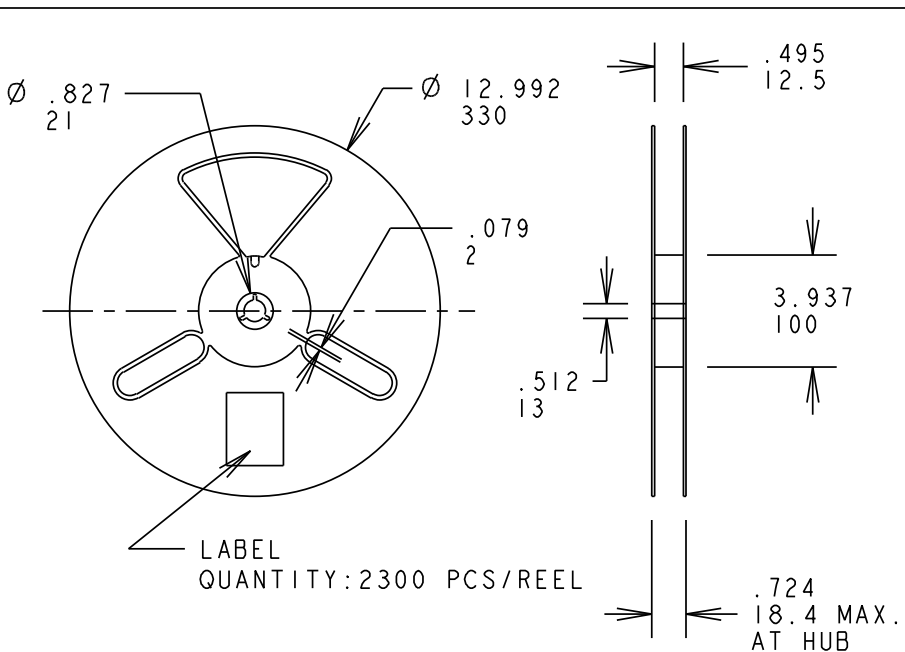

13 INCH DIA. REEL SPECIFICATIONS

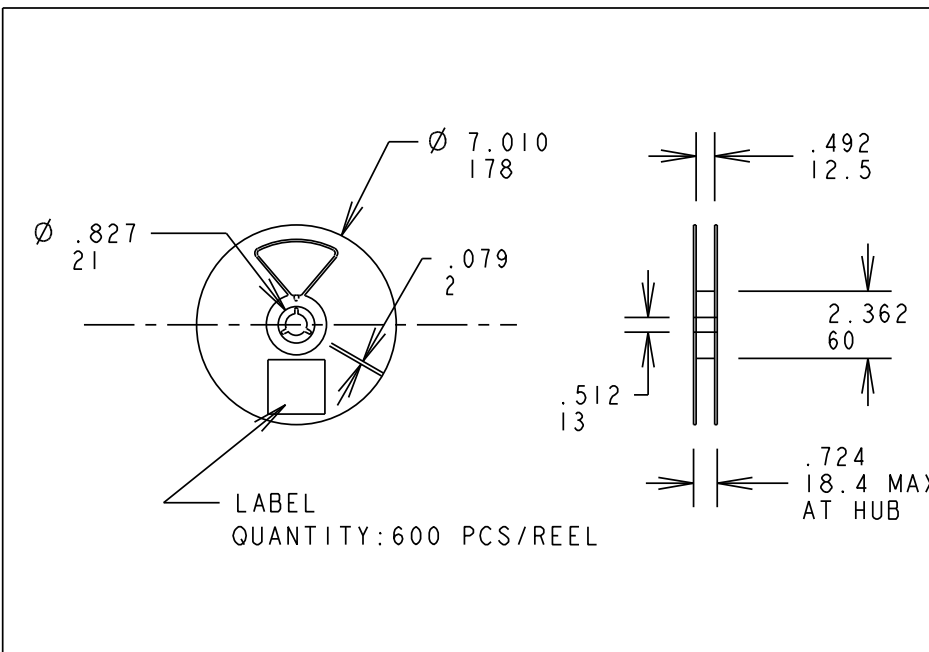

7 INCH DIA. REEL SPECIFICATIONS

RoHS Compliant 595-2X01-OXXF Surface Mount CBI

Part Numbers with the "F" suffix ending are RoHS Compliant.
Example: 595-2101-002F
Packaging is marked with "RoHS Compliant" label or equivalent markings.
Parts can be wave soldered, dip soldered or hand soldered using typical lead-free soldering process with max 260°C temp. for 5 sec.

THIS DRAWING AND THE CONTENTS HEREIN ARE CONFIDENTIAL AND THE SOLE PROPERTY OF DIALIGHT. REPRODUCTION OF THIS DRAWING OR CONSTRUCTION OF ANY PARTS WITHIN THIS DRAWING ARE FORBIDDEN WITHOUT THE WRITTEN CONSENT OF DIALIGHT.		
SCALE: DRAWING SCALE	DRAWING NUMBER	REV
ALL DIM'S IN: INCHES (MM)	C-17345	A
TOLERANCES: UNLESS OTHERWISE SPECIFIED	TITLE SURFACE MOUNT CBI	
FRACTIONS: ±1/64	MATERIAL RoHS COMPLIANT	
DECIMALS (.XX): ±.01	DIALIGHT	
DECIMALS (.XXX): ±.005	1501 ROUTE 34 SOUTH	
DECIMALS (.XXXX): ±.0005	FARMINGDALE, NJ 07727	
ANGLES: ±1°	FSCM 83330	
FINISH:	SHEET 1 OF 1 FAMILY TABLE:	