

Dial Caliper

SERIES 505

FEATURES

- New designed dial movement for ultra smooth sliding and high shock protection.
- Titanium coating is applied to the sliding surface to strengthen the durability (except for 0 - 300mm and 0 - 12" model). No wearing by 100,000-time sliding test.
- Can measure OD, ID, depth, and steps.
- Clamping screw atop the slider.
- Special models available with carbide-tipped OD and ID jaws.



(Refer to the page 9 for details.)

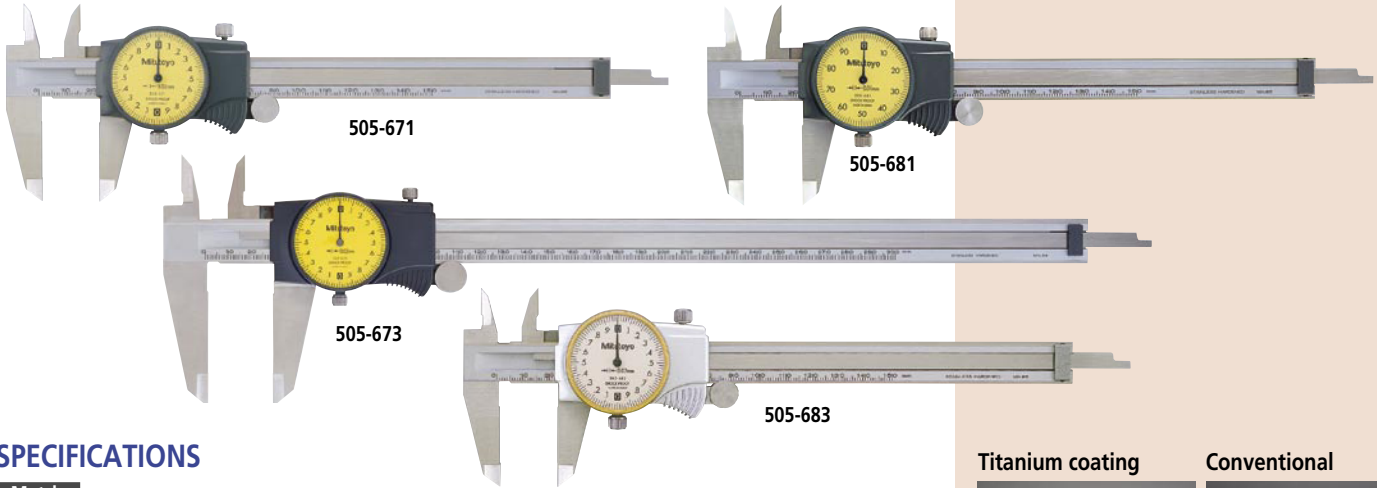

SPECIFICATIONS

Metric			
Range	Order No.	Accuracy	Remarks (dial reading / others)
0 - 100mm	505-680	±0.015mm	0.01mm, 1mm/rev —
0 - 150mm	505-671 / 505-683*	±0.03mm	0.02mm, 2mm/rev —
0 - 150mm	505-707	±0.03mm	0.02mm, 2mm/rev Carbide-tipped jaws for OD measurement
0 - 150mm	505-711	±0.03mm	0.02mm, 2mm/rev Carbide-tipped jaws for OD & ID measurement
0 - 150mm	505-681 / 505-685*	±0.02mm	0.01mm, 1mm/rev —
0 - 200mm	505-672 / 505-684*	±0.03mm	0.02mm, 2mm/rev —
0 - 200mm	505-682 / 505-686*	±0.03mm	0.01mm, 1mm/rev —
0 - 300mm	505-673	±0.04mm	0.02mm, 2mm/rev —

*Silver cover type

Inch			
Range	Order No.	Accuracy	Remarks (dial reading / others)
0 - 4"	505-674	±.001"	.001", .1"/rev —
0 - 6"	505-675 / 505-689*	±.001"	.001", .1"/rev —
0 - 6"	505-708	±.001"	.001", .1"/rev Carbide-tipped jaws for OD measurement
0 - 6"	505-712	±.001"	.001", .1"/rev Carbide-tipped jaws for OD & ID measurement
0 - 8"	505-676 / 505-690*	±.002"	.001", .1"/rev —
0 - 8"	505-709	±.002"	.001", .1"/rev Carbide-tipped jaws for OD measurement
0 - 8"	505-713	±.002"	.001", .1"/rev Carbide-tipped jaws for OD & ID measurement
0 - 12"	505-720	±.002"	.001", .2"/rev —
0 - 12"	505-677*	±.002"	.001", .1"/rev —
0 - 12"	505-721	±.002"	.001", .2"/rev Carbide-tipped jaws for OD measurement
0 - 12"	505-710*	±.002"	.001", .1"/rev Carbide-tipped jaws for OD measurement
0 - 12"	505-714*	±.002"	.001", .1"/rev Carbide-tipped jaws for OD & ID measurement

*Silver cover type

Titanium coating



Wear: 0µm

Conventional



Wear: 4µm

Technical Data

Accuracy: Refer to the list of specifications.
Dial reading: Refer to the list of specifications.

DIMENSION

