

REVISIONS

REV	ECO	DESCRIPTION	DATE	BY	APPR
A1		FIRST RELEASE	08JAN18	WILBER	TOMMY

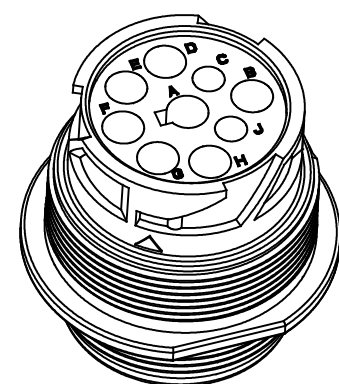

3D VIEW

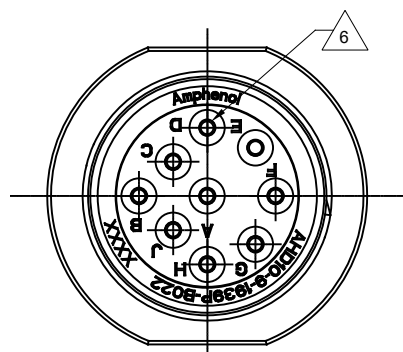
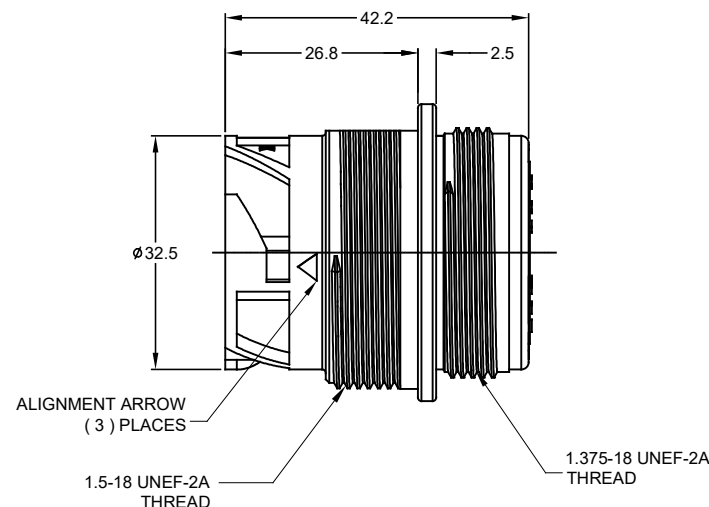
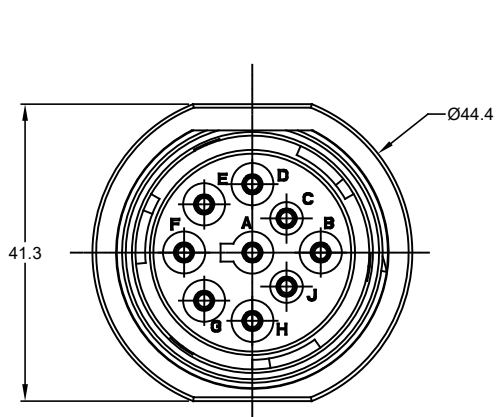
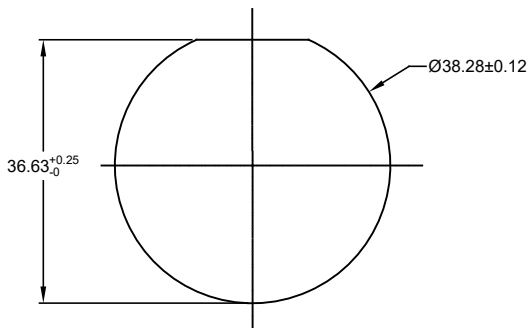

RECOMMENDED PANEL MOUNTING HOLE

RECOMMENDED PANEL THICKNESS :1.57 TO 4.77

CONTACT SIZE AND WIRE SEAL RANGE:

PART NUMBER	SEAL TYPE	CONTACT SIZE	MIN. INSUL O.D.	MAX. INSUL O.D.	TYPICAL WIRE RANGE
AHD10-9-1939P-B022	STANDARD	16	2.54 mm (.100 in)	3.81 mm (.150 in)	14 - 20 AWG
AHD10-9-1939PR-B022	REDUCED	16	1.35 mm (.053 in)	3.05 mm (.120 in)	14 - 20 AWG

NOTES: UNLESS OTHERWISE SPECIFIED

- MATERIAL:
HOUSING: THERMOPLASTIC; COLOR: BLACK
SEAL: SILICONE RUBBER
- MODIFICATIONS: J1939-13 TYPE I ;
OPTIONAL REDUCED DIA. WIRE SEAL
(SEE NOTE 6)
- SPECIFICATIONS:
3.1 CURRENT RATING: 13 AMPS
3.2 OPERATING TEMPERATURE: -55°C TO +125°C.
3.3 DIELECTRIC WITHSTANDING VOLTAGE: LESS THAN 2 MILLIAMPS CURRENT LEAKAGE @ 1500 VOLTS AC.
3.4 INSULATION RESISTANCE: 1000 MEGOHM MIN @ 25°C.
3.5 MOISTURE RESISTANCE: IP67 (MATED CONDITION).
3.6 MATING CYCLE DURABILITY: 100 CYCLES
3.7 RoHS COMPLIANT
- MATING PART: AHD17-9-1939S* OR AHD16-9-1939S*
(* = AVAILABLE MODIFICATIONS)
- ALL DIMENSIONS ARE FOR REFERENCE USE ONLY.

SEE NOTE 6		PART NUMBER		DESCRIPTION		ITEM
QUANTITY						
MATERIALS LIST						
UNLESS OTHERWISE SPECIFIED: 1) All dimensions are in metric (mm). 2) Tolerances are as follows: 1 PL DEC ±0.30 2 PL DEC ±0.15 3 PL DEC ±0.08 Fractions ±1/64 Angles ±1°			SIGNATURES		DATE	
3) Note reference =			DRAWN: Wilber		08JAN18	
MATERIAL SPECIFICATIONS:			CHECKED: Orion		08JAN18	
PROCESS SPECIFICATIONS:			APPROVAL: Tommy		08JAN18	
NEXT ASSY:			CUSTOMER:		THIS DRAWING IS SUPPLIED FOR INFORMATION ONLY. DESIGN FEATURES, SPECIFICATIONS AND PERFORMANCE DATA SHOWN HEREON ARE THE PROPERTY OF THE AMPHENOL CORPORATION. NO RIGHTS OF REPRODUCTION ARE IMPLIED. ALL DIMENSIONS ARE SUBJECT TO NORMAL MANUFACTURING VARIATIONS.	
Amphenol				Sine Systems - www.amphenol-sine.com 44724 Morley Drive Clinton Township, MI 48036		
RECEPTACLE, J1939-13 TYPE I, 9 POS., PANEL MOUNT, D-HOLE, AHD SERIES						
SIZE	TYPE	DWG NO.	REVISION		A1	
B	C-	AHD10-9-1939PX-B022				
SCALE NONE						
					SHEET 1 OF 1	

TITLE: REC: J1939-13 TYPE I, 9 POS, PANEL MOUNT, D-HOLE, AHD DWG NO: AHD10-9-1939PX-B022 REV: A1 SH: 1 OF: 1