

Oct.1.2018 Copyright 2018 HIROSE ELECTRIC CO., LTD. All Rights Reserved.
 In case that the application demands a high level of reliability, such as automotive,
 please contact a company representative for further information.

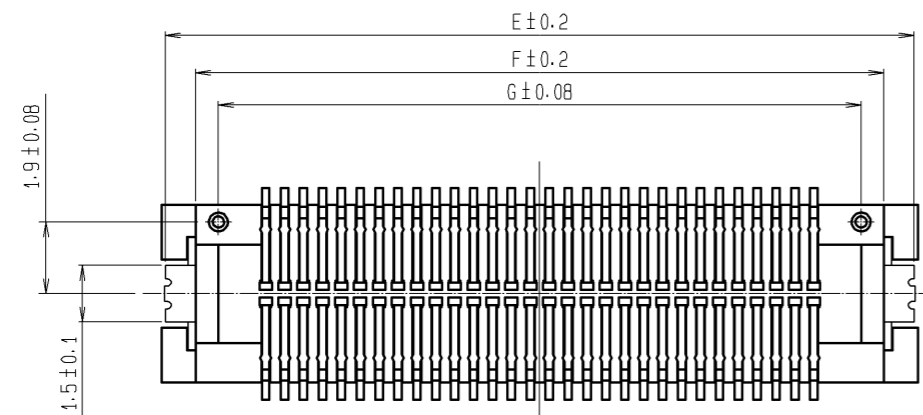
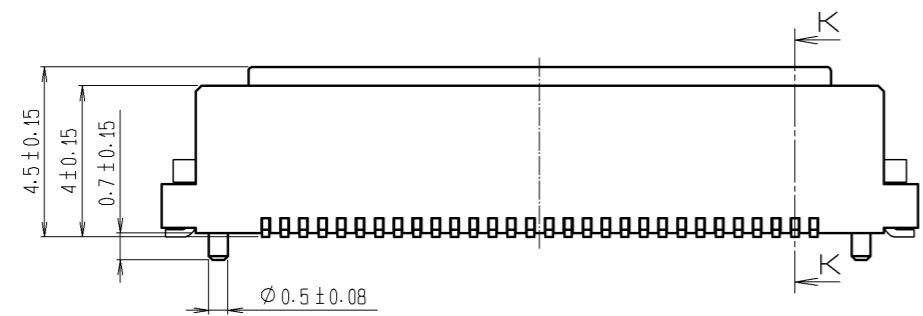
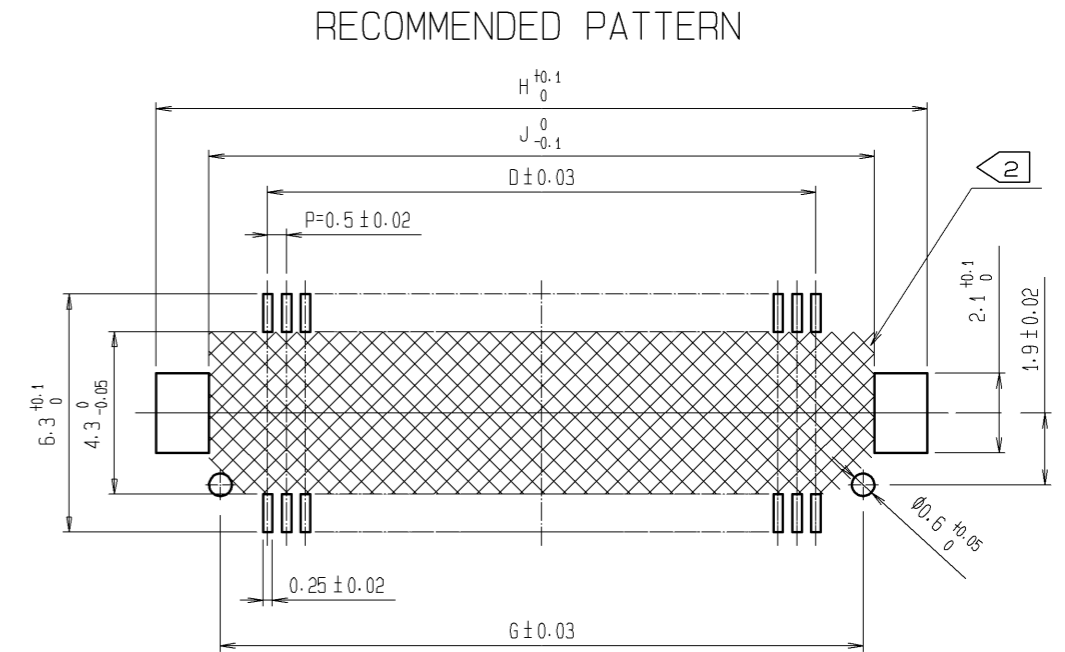
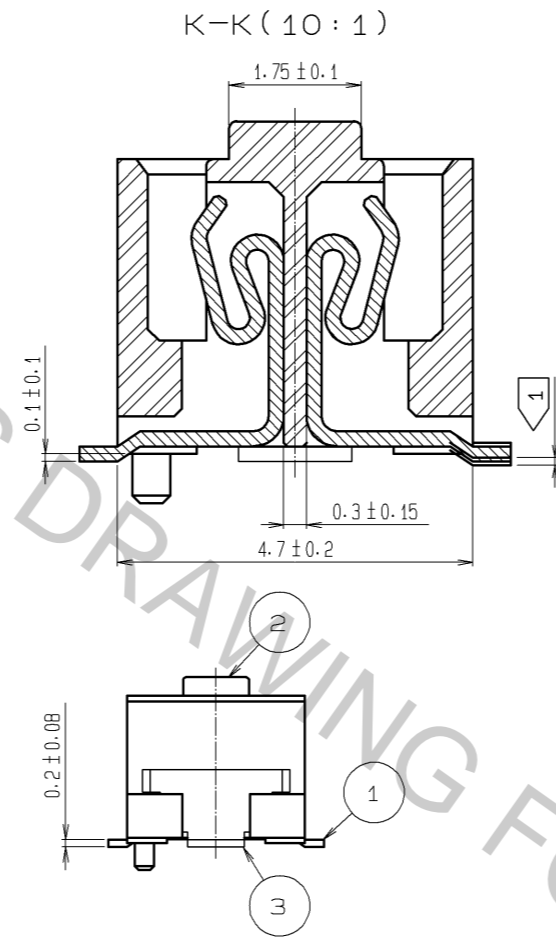
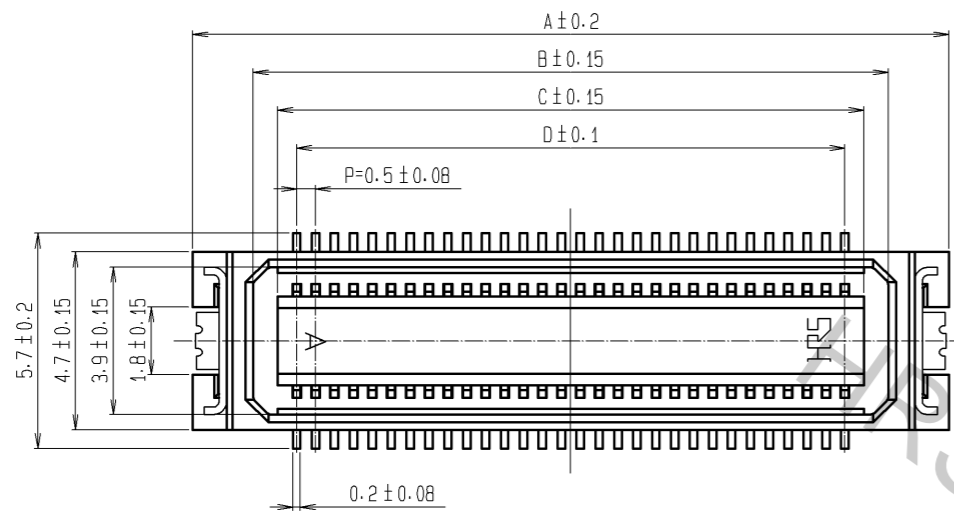

CODE NO.	CONTACT	A	B	C	D	E	F	G	H	J
CL683-0042-7-57	20	10	6.8	5.5	4.5	9.8	8.2	7	10.4	7.6
CL683-0043-0-57	30	12.5	9.3	8	7	12.3	10.7	9.5	12.9	10.1
CL683-0044-2-57	40	15	11.8	10.5	9.5	14.8	13.2	12	15.4	12.6
CL683-0045-5-57	50	17.5	14.3	13	12	17.3	15.7	14.5	17.9	15.1
CL683-0046-8-57	60	20	16.8	15.5	14.5	19.8	18.2	17	20.4	17.6
CL683-0047-0-57	70	22.5	19.3	18	17	22.3	20.7	19.5	22.9	20.1
CL683-0048-3-57	80	25	21.8	20.5	19.5	24.8	23.2	22	25.4	22.6

NOTES 1 LEAD CO-PLANARITY INCLUDE REINFORCED METAL FITTINGS SHALL BE 0.1mm MAX.
 2 WATCH NOT LET THE CONTACTS TOUCH THE SECTION ESPECIALLY WHEN THE PADS OF AREA NOT RESIST FINISHED.

MATED HEIGHT(h)		(mm)
HEADER NO.	RECEPTACLE NO.	
	DF17#(4.0)-*DS-0.5V(57)	
DF17#(2.0)-*DP-0.5V(57)		6
DF17#(4.0)-*DP-0.5V(57)		8

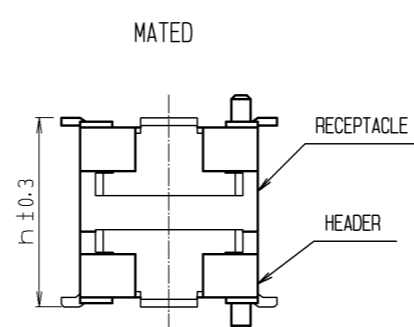

NO.	MATERIAL	FINISH . REMARKS	NO.	MATERIAL	FINISH . REMARKS
2	POLYAMIDE (PA6T)	WHITE BEIGE , UL94V-0	6	PS	BLACK(PLASTIC REEL)
			5	POLYESTER	CLEAR (COVER TAPE)
1	PHOSPHER BRONZE	CONTACT AREA : GOLD PLATED 0.1µm min LEAD AREA : TIN PLATED 1µm min UNDER PLATING : NICKEL PLATED 1µm min	4	PS	CLEAR (EMBOSSED CARRIER TAPE)
			3	PHOSPHER BRONZE	TIN PLATED : 1µm min UNDER PLATING : NICKEL PLATED 1µm min

UNITS	SCALE	COUNT	DESCRIPTION OF REVISIONS	DESIGNED	CHECKED	DATE
mm	5 : 1	△	APPROVED : KH. IKEDA 11.11.30 CHECKED : TS. MIYAZAKI 11.11.30 DESIGNED : YH. MICHIDA 11.11.30 DRAWN : YH. MICHIDA 11.11.30			

DRAWING NO.	PART NO.	CODE NO.
EDC3-162131-77	DF17(4.0)-*DS-0.5V(57)	CL683

Oct.1.2018 Copyright 2018 HIROSE ELECTRIC CO., LTD. All Rights Reserved.
 In case that the application demands a high level of reliability, such as automotive,
 please contact a company representative for further information.

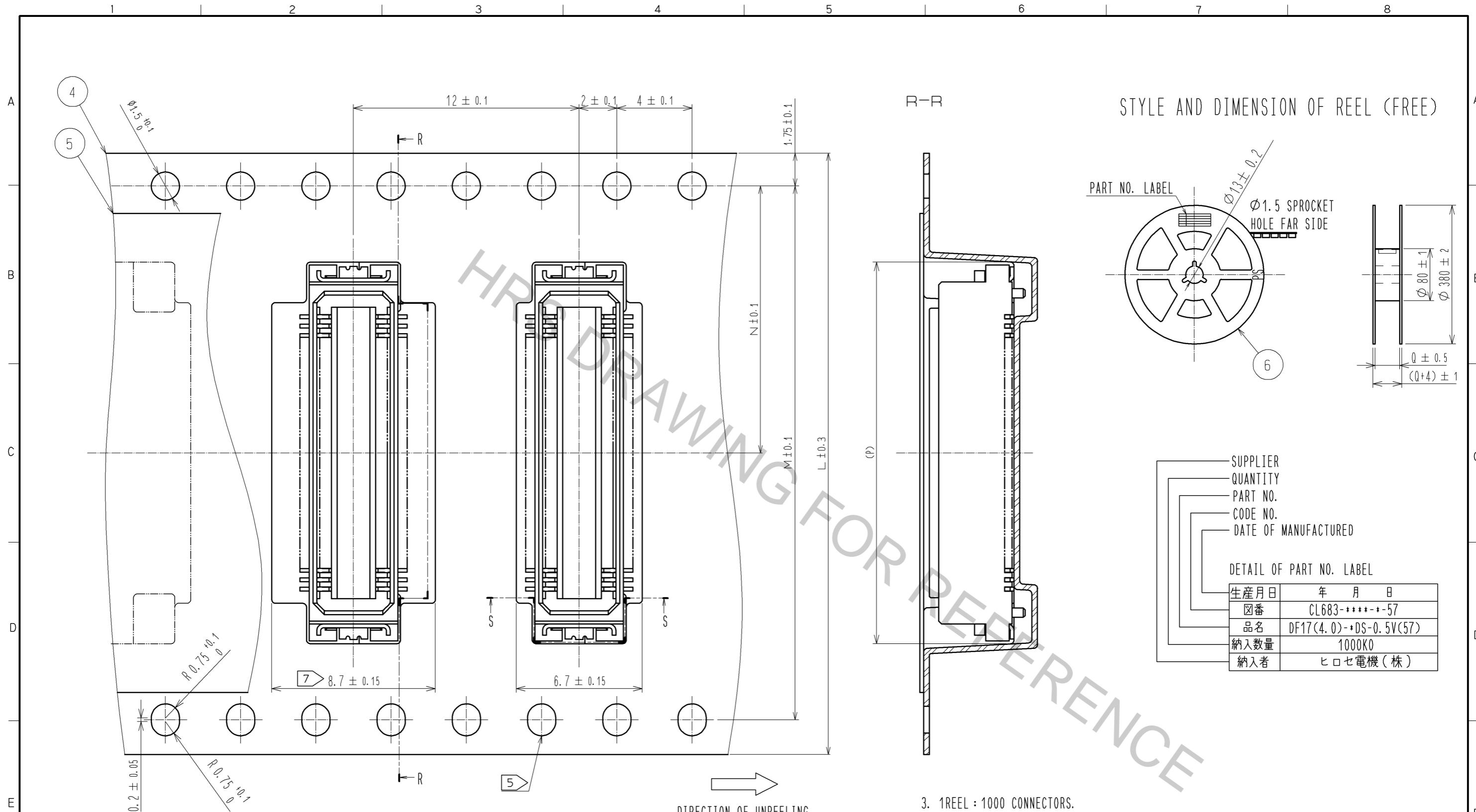

STYLE AND DIMENSION OF REEL (FREE)

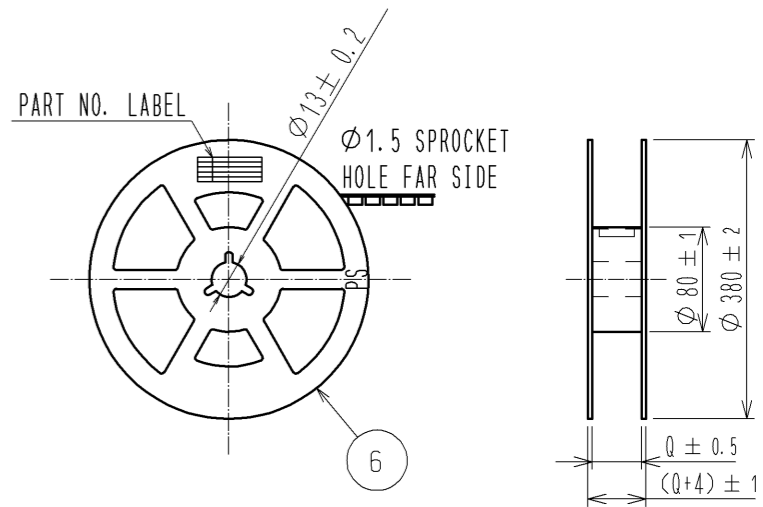

SUPPLIER
 QUANTITY
 PART NO.
 CODE NO.
 DATE OF MANUFACTURED

DETAIL OF PART NO. LABEL

生産月日	年 月 日
図番	CL683-****-57
品名	DF17(4.0)-*DS-0.5V(57)
納入数量	1000K0
納入者	ヒロセ電機(株)

→ DIRECTION OF UNREELING

- 3. 1 REEL : 1000 CONNECTORS.
- 4. AT THE BEGINNING OF THE REEL , 30 COMPONENTS SHALL BE EMPTY.
 AT THE END OF THE REEL , 20 COMPONENTS SHALL BE EMPTY.
- 5. WHEN THE TAPE WIDTH IS 32mm or 44mm, SPROCKET HOLES SHALL BE SET ON BOTH SIDES OF REEL AS SHOWN ON THIS DRAWING.
- 6. PEEL FORCE REFERS TO JIS C 0806.
- 7. A POCKET SHAPE IS DIFFERENT AT INTERVALS OF EACH CAVITY NUMBER TO AVOID OVERLAP.

CODE NO.	CONTACT	L	M	N	P	Q
CL683-0042-7-57	20	24	-	11.5	10.3	25.5
CL683-0043-0-57	30	24	-	11.5	12.8	25.5
CL683-0044-2-57	40	24	-	11.5	15.3	25.5
CL683-0045-5-57	50	32	28.4	14.2	17.8	33.5
CL683-0046-8-57	60	32	28.4	14.2	20.3	33.5
CL683-0047-0-57	70	44	40.4	20.2	22.8	45.5
CL683-0048-3-57	80	44	40.4	20.2	25.3	45.5

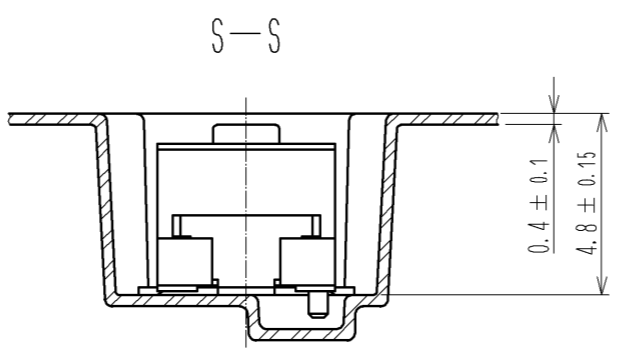

HRS	DRAWING NO.	EDC3-162131-77
	PART NO.	DF17(4.0)-*DS-0.5V(57)
	CODE NO.	CL683
		△ 2/2