

Oct.1.2018 Copyright 2018 HIROSE ELECTRIC CO., LTD. All Rights Reserved.
 In case that the application demands a high level of reliability, such as automotive,
 please contact a company representative for further information.

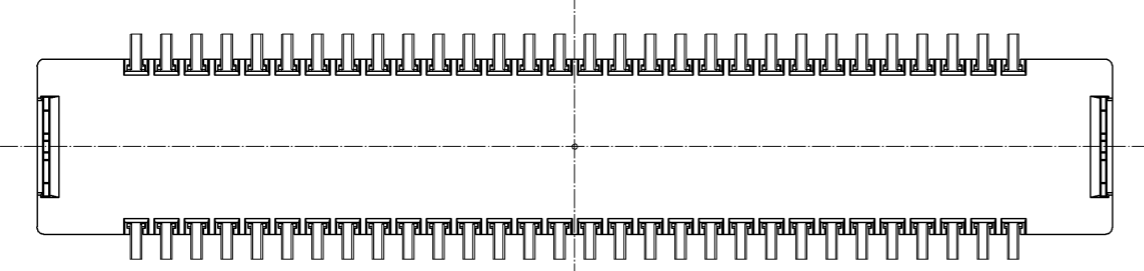
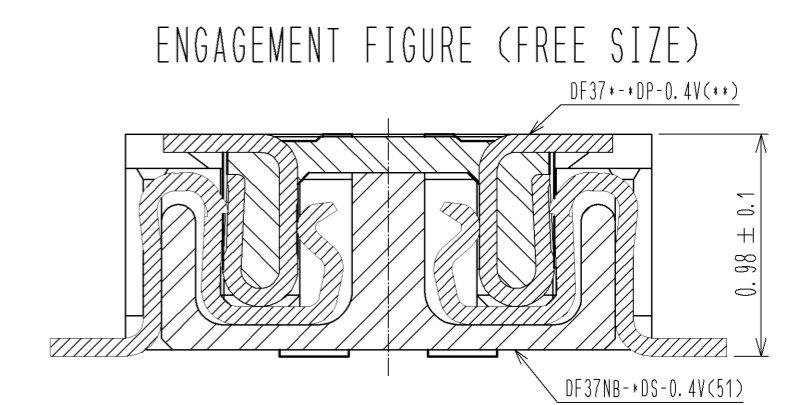
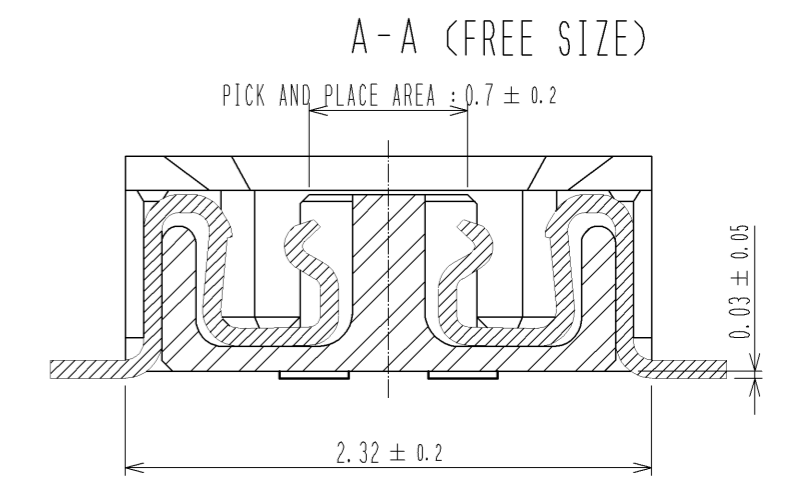
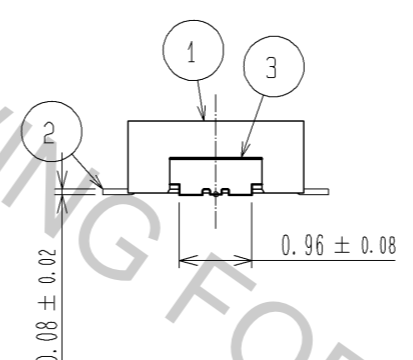
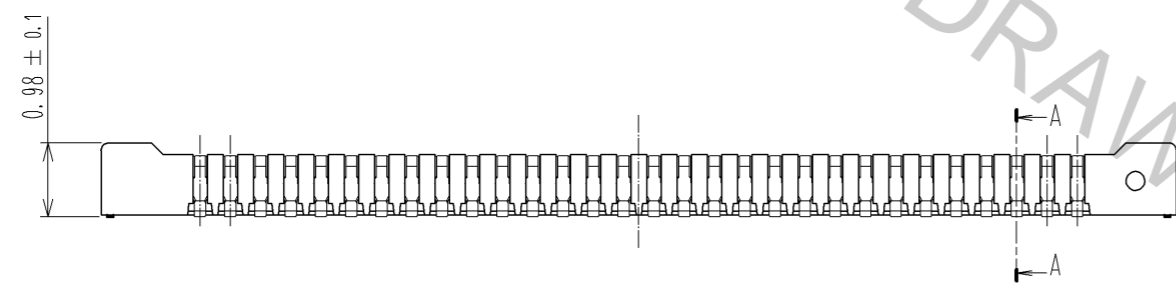
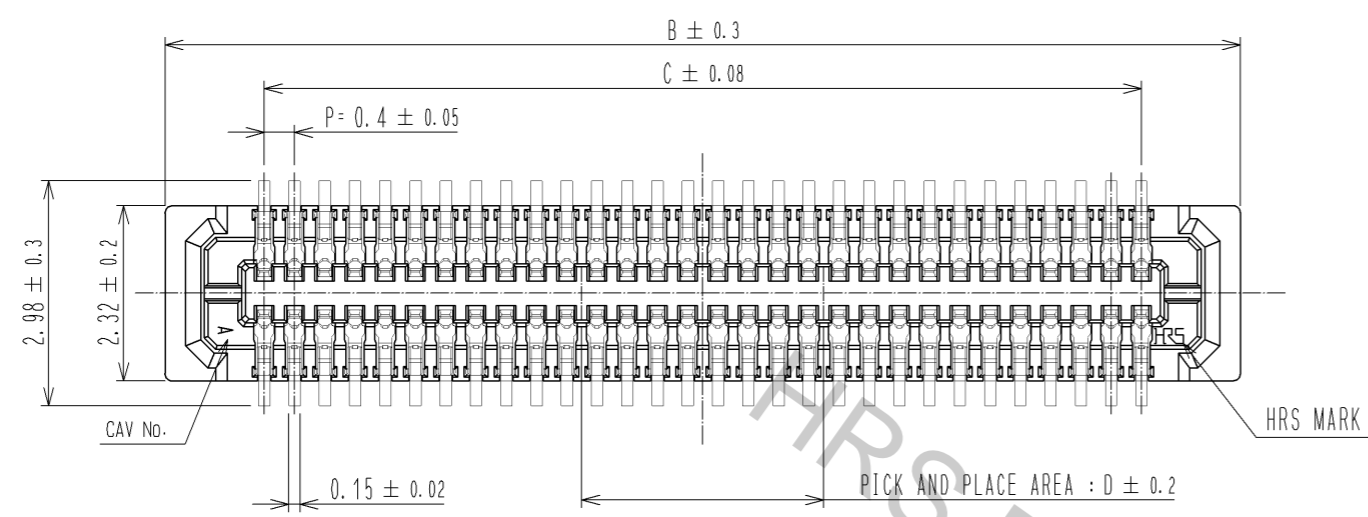

NOTE 1. ALL LEADS CO-PLANARITY SHALL BE 0.1mm MAX.
 ② CONTACT PLATING SPECIFICATIONS.
 CONTACT AREA : GOLD 0.05 μm MIN.
 SMT LEAD : GOLD 0.05 μm MIN.
 UNDERPLATING : NICKEL 1 μm MIN.
 (SURFACE : SEALING)
 ③ METAL HOLD DOWN PLATING SPECIFICATIONS.
 MOUNTING AREA: GOLD 0.05 μm MIN.
 UNDERPLATING : NICKEL 1 μm MIN.

PART No.	CL No.	B	C	D
DF37NB-10DS-0.4V(51)	CL684-3301-6-51	4.22	1.6	0.8
DF37NB-16DS-0.4V(51)	CL684-3302-9-51	5.42	2.8	1.2
DF37NB-20DS-0.4V(51)	CL684-3303-1-51	6.22	3.6	1.6
DF37NB-24DS-0.4V(51)	CL684-3304-4-51	7.02	4.4	2.0
DF37NB-30DS-0.4V(51)	CL684-3305-7-51	8.22	5.6	2.0
DF37NB-34DS-0.4V(51)	CL684-3082-4-51	9.02	6.4	2.4
DF37NB-40DS-0.4V(51)	CL684-3306-0-51	10.22	7.6	2.4
DF37NB-44DS-0.4V(51)	CL684-3407-7-51	11.02	8.4	2.8
DF37NB-50DS-0.4V(51)	CL684-3307-2-51	12.22	9.6	2.8
DF37NB-60DS-0.4V(51)	CL684-3308-5-51	14.22	11.6	3.2
DF37NB-70DS-0.4V(51)	CL684-3409-2-51	16.22	13.6	3.6
DF37NB-74DS-0.4V(51)	CL684-3080-9-51	17.02	14.4	4.0

3	PHOSPHOR BRONZE	③	6	PS	PLASTIC REEL (BLACK)						
2	PHOSPHOR BRONZE	②	5	POLYESTER	CLEAR (COVER TAPE)						
1	LCP	UL94V-0, BLACK	4	PS	CLEAR (EMBOSSED CARRIER TAPE)						
NO.	MATERIAL	FINISH, REMARKS	NO.	MATERIAL	FINISH, REMARKS						
UNITS	mm	SCALE	FREE	COUNT	3	DESCRIPTION OF REVISIONS	DESIGNED	CHECKED	DATE		
				DIS-H-005494		KR. AJITO		TS. MIYAZAKI		11.02.04	
APPROVED : KH. IKEDA		09.10.23		DRAWING NO.		EDC3-319685-02					
CHECKED : TS. MIYAZAKI		09.10.23		PART NO.		DF37NB-*DS-0.4V(51)					
DESIGNED : RT. SHIMIZU		09.10.23		CODE NO.							
DRAWN : YN. SAKAMOTO		09.10.20									

◆ RECOMMENDED PCB LAYOUT(MOUNTING SURFACE SIDE)

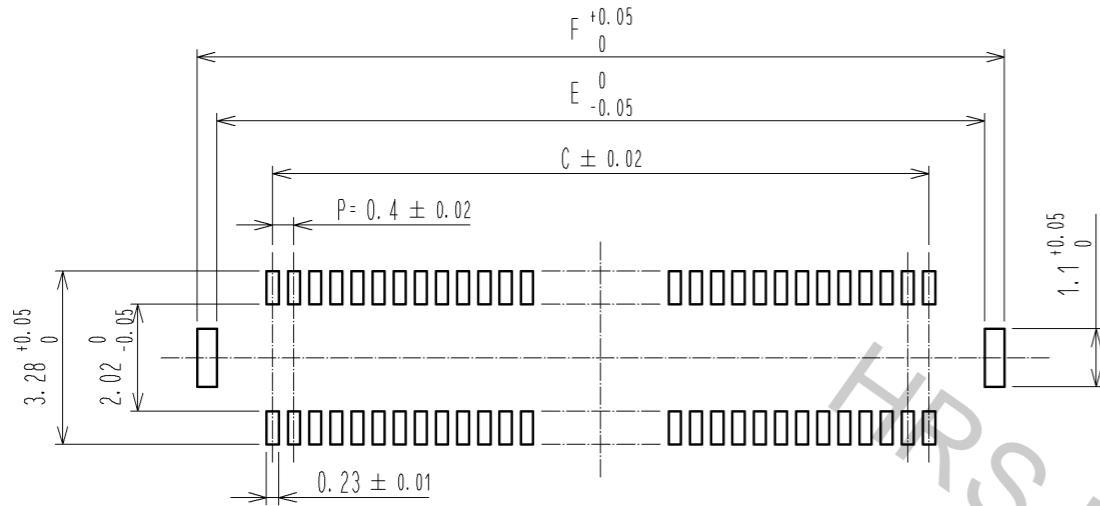

◆ RECOMMENDED METAL MASK DIMENSIONS
 METAL MASK THICKNESS : 0.12mm

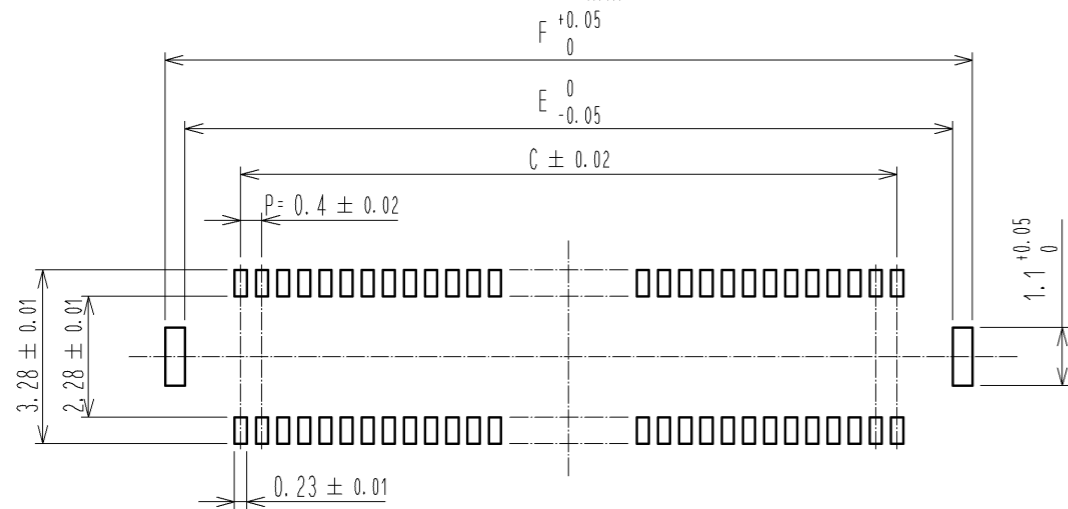

◆ RECOMMENDED METAL MASK DIMENSIONS
 METAL MASK THICKNESS : 0.1mm

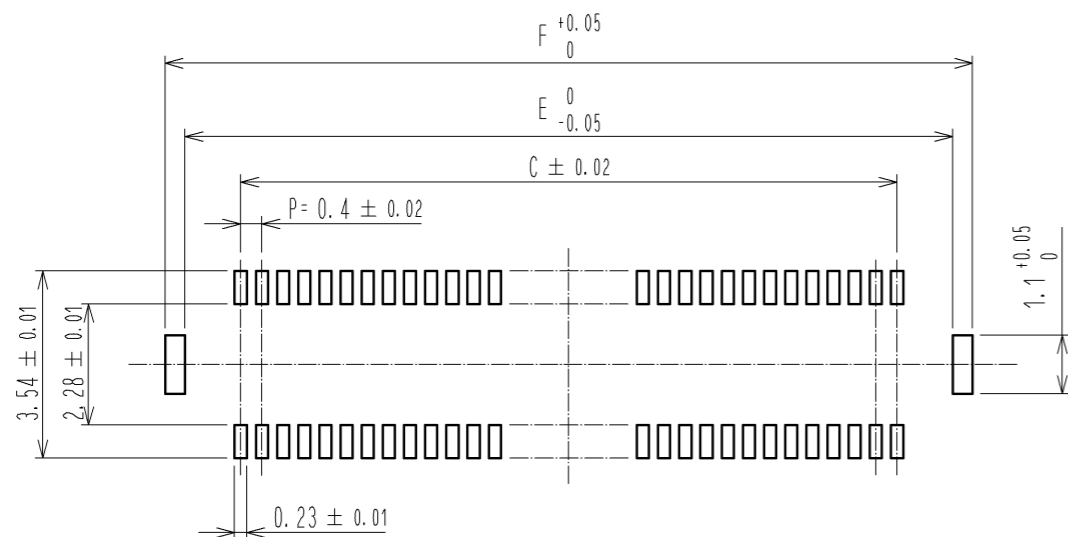

△ 1

PART No.	C	E	F
DF37NB-10DS-0.4V(51)	1.6	3.7	4.46
DF37NB-16DS-0.4V(51)	2.8	4.9	5.66
DF37NB-20DS-0.4V(51)	3.6	5.7	6.46
DF37NB-24DS-0.4V(51)	4.4	6.5	7.26
DF37NB-30DS-0.4V(51)	5.6	7.7	8.46
DF37NB-34DS-0.4V(51)	6.4	8.5	9.26
DF37NB-40DS-0.4V(51)	7.6	9.7	10.46
DF37NB-44DS-0.4V(51)	8.4	10.5	11.26
DF37NB-50DS-0.4V(51)	9.6	11.7	12.46
DF37NB-60DS-0.4V(51)	11.6	13.7	14.46
DF37NB-70DS-0.4V(51)	13.6	15.7	16.46
DF37NB-74DS-0.4V(51)	14.4	16.5	17.26

4 RECOMMENDED REFLOW TEMPERATURE PROFILE USING LEAD-FREE SOLDER PASTE.

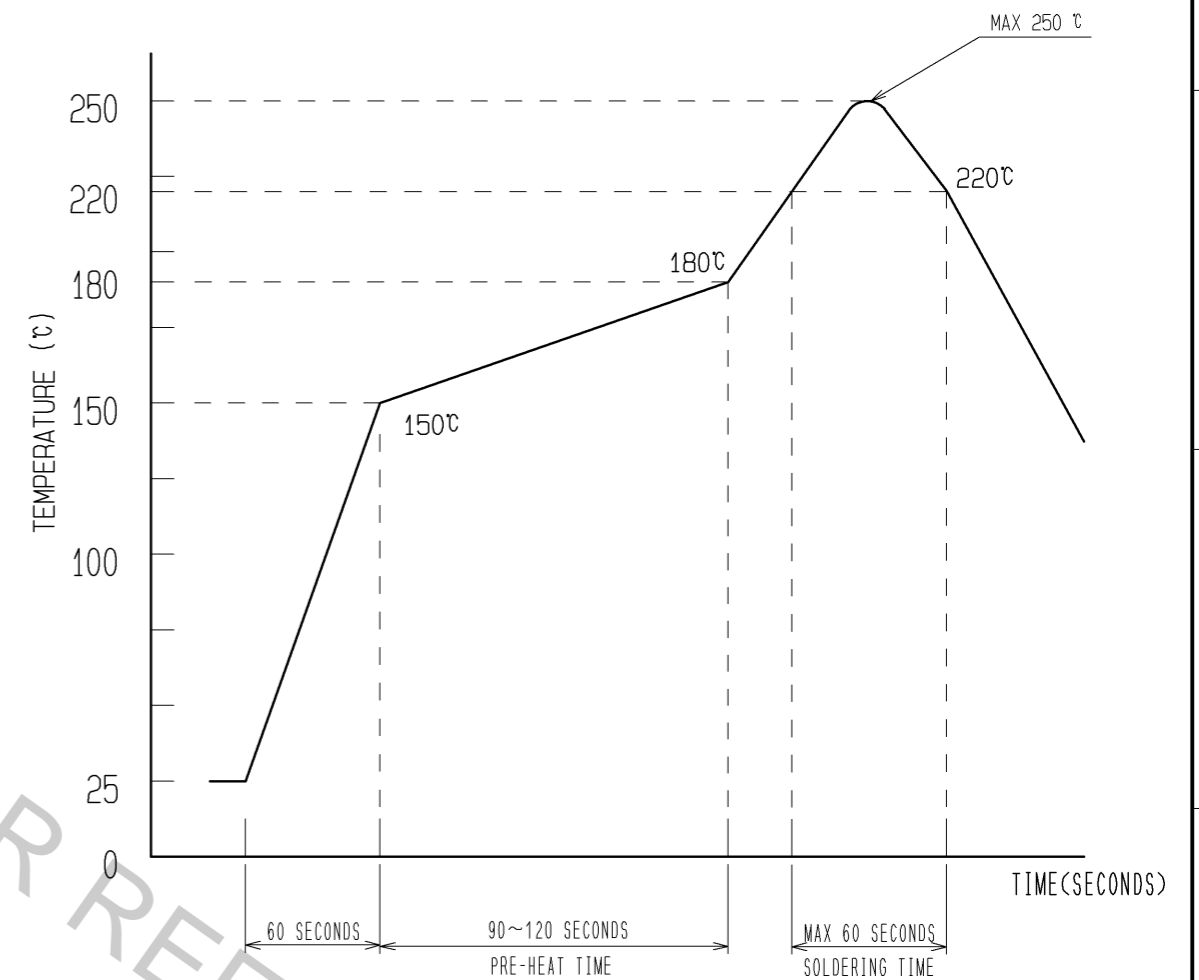

- 1) REFLOW TIME
 REFLOW METHOD: IR REFLOW
 NUMBER OF REFLOW CYCLES: 2 CYCLES MAX.
 DURATION ABOVE 220 °C: 60 SEC. MAX.
 (PEAK TEMPERATURE: 250°C MAX.)
- 2) PRE-HEAT TIME
 PRE-HEAT TEMPERATURE(MIN) : 150 °C
 PRE-HEAT TEMPERATURE(MAX) : 180 °C
 PRE-HEAT TIME : 90~120 sec.

4 THIS TEMPERATURE PROFILE IS PER THE CONDITIONS SHOWN ABOVE.
 ADDITIONAL FACTORS, SUCH AS SOLDER PASTE TYPE, PCB SIZE AND
 OTHER MOUNTED COMPONENTS COULD AFFECT THE PROFILE. THEREFORE,
 A THOROUGH EVALUATION OF MOUNTING CONDITION IS REQUIRED
 PRIOR TO PRODUCTION. TEMPERATURE IS MEASURED AT CONTACT LEAD.

HRS

DRAWING NO.	EDC3-319685-02
PART NO.	DF37NB-*DS-0.4V(51)
CODE NO.	

EMBOSSED CARRIER TAPE PACKAGING (FREE SIZE)

◆ UNDER 60 POS.

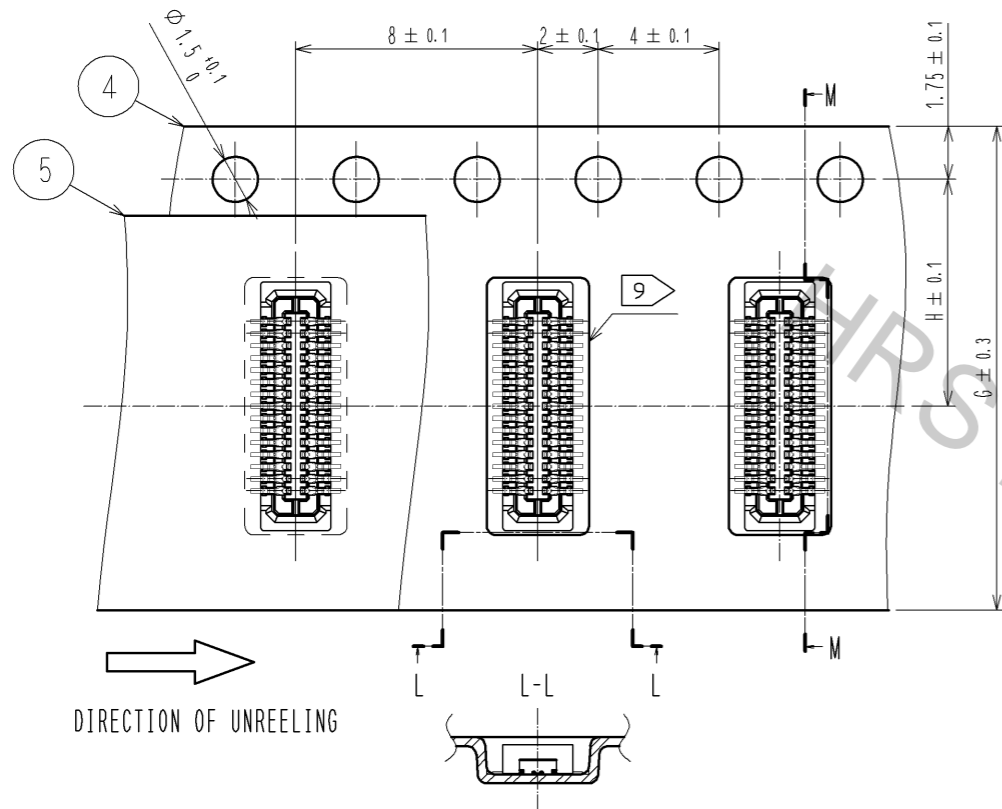

◆ 70 POS. AND ABOVE

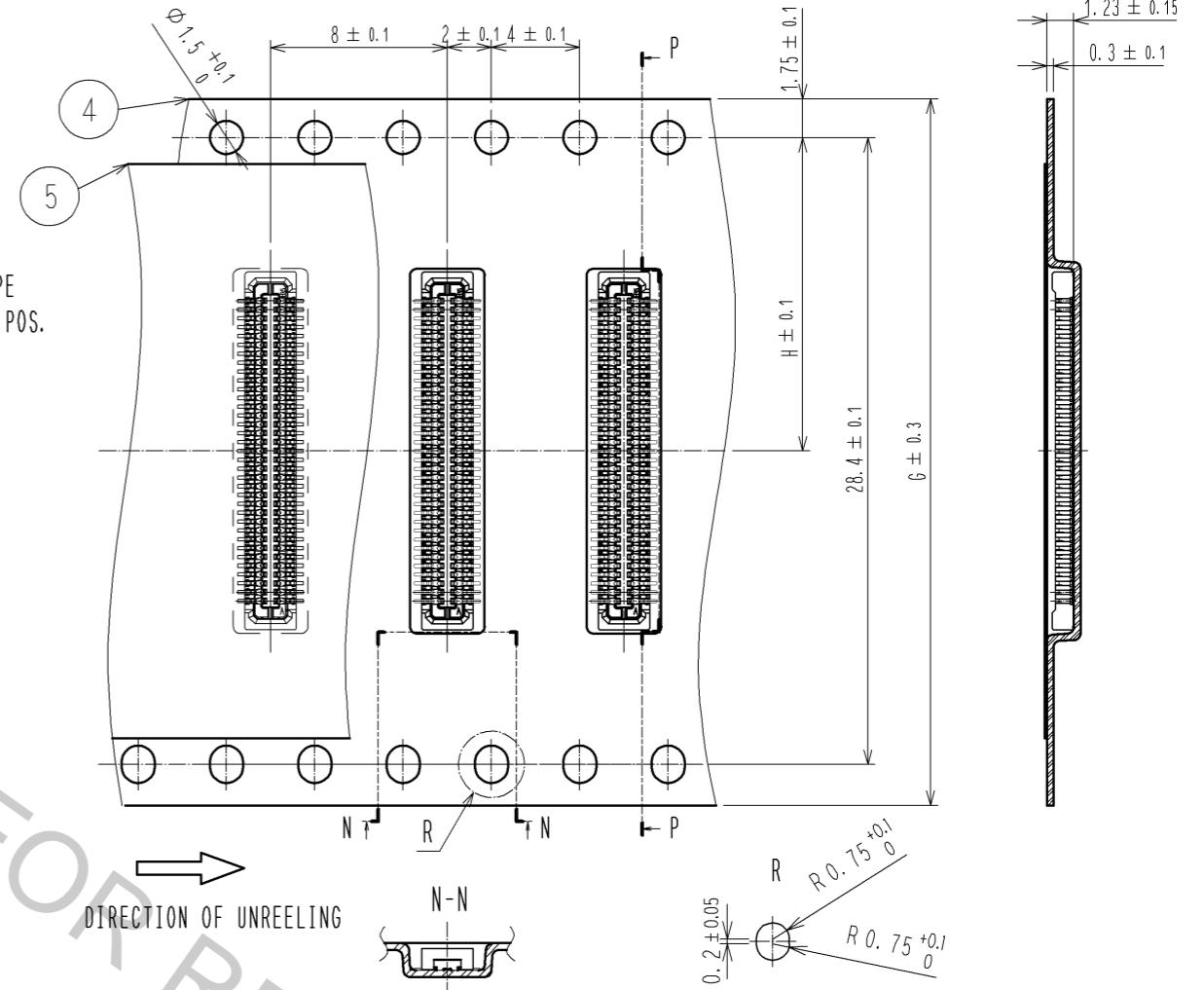

STYLE AND DIMENSION OF REEL (FREE SIZE)

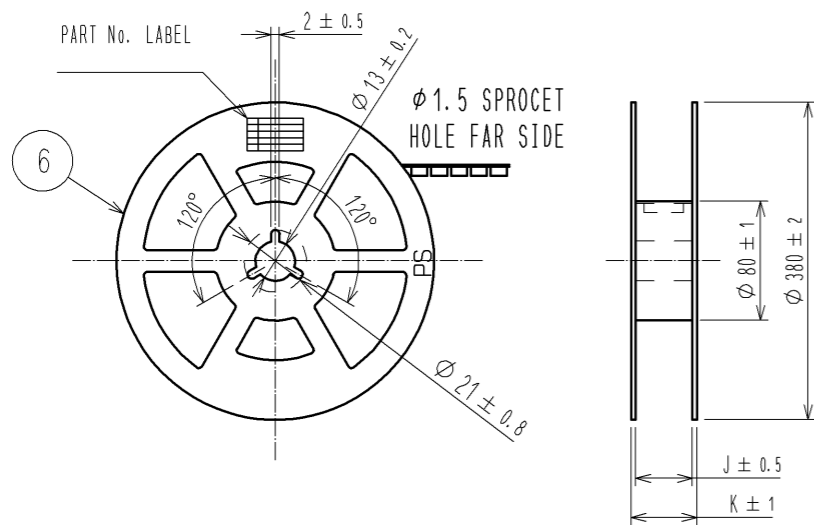

DETAIL OF PART No. LABEL

SUPPLIER	HIROSE ELECTRIC CO., LTD.
QUANTITY	8000
PART NO.	DF37NB-DS-0.4V(51)
CODE NO.	** ** *
DATE OF MANUFACTURED	年 月 日
製造年月日	年 月 日
製品コード	** ** *
製品名	DF37NB-DS-0.4V(51)
数量	8000個
納入者	ヒロセ電機(株)

PART No.	G	H	J	K
DF37NB-10DS-0.4V(51)	16	7.5	17.5	21.5
DF37NB-16DS-0.4V(51)	16	7.5	17.5	21.5
DF37NB-20DS-0.4V(51)	16	7.5	17.5	21.5
DF37NB-24DS-0.4V(51)	16	7.5	17.5	21.5
DF37NB-30DS-0.4V(51)	24	11.5	25.5	29.5
DF37NB-34DS-0.4V(51)	24	11.5	25.5	29.5
DF37NB-40DS-0.4V(51)	24	11.5	25.5	29.5
DF37NB-44DS-0.4V(51)	24	11.5	25.5	29.5
DF37NB-50DS-0.4V(51)	24	11.5	25.5	29.5
DF37NB-60DS-0.4V(51)	24	11.5	25.5	29.5
DF37NB-70DS-0.4V(51)	32	14.2	37.5	33.5
DF37NB-74DS-0.4V(51)	32	14.2	37.5	33.5

NOTES 5. PER REEL 8000 CONNECTORS.

6. THE DIMENSIONS IN PARENTHESSES ARE FOR REFERENCE.

7. REFER TO JIS C 0806(PACKING OF COMPONENTS FOR AUTOMATIC HANDLING)

8. DETAIL OF PART NO. LABEL IS WRITTEN IN JAPANESE.

9. EMBOSS POCKET OF LESS THAN 20 POS. SHALL BE CROSS.

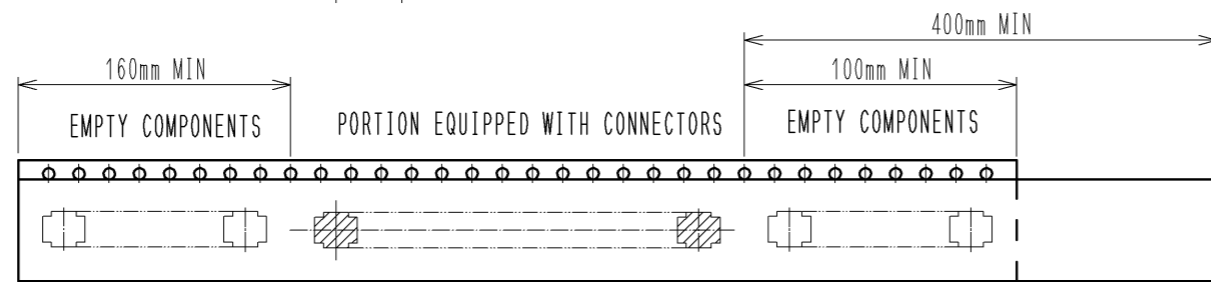

HRS

DRAWING NO.	EDC3-319685-02
PART NO.	DF37NB-DS-0.4V(51)
CODE NO.	

3/3