

Oct.1.2018 Copyright 2018 HIROSE ELECTRIC CO., LTD. All Rights Reserved.
 In case that the application demands a high level of reliability, such as automotive,
 please contact a company representative for further information.

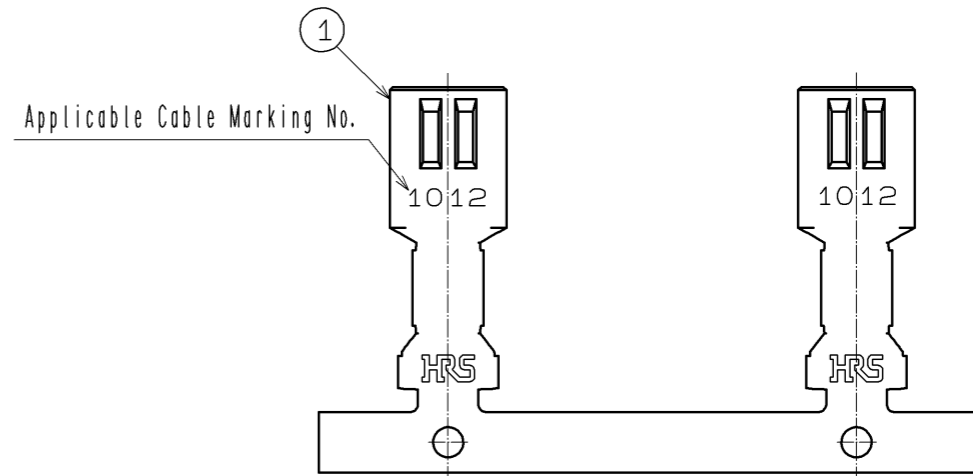

2 Style and Dimension of Reel

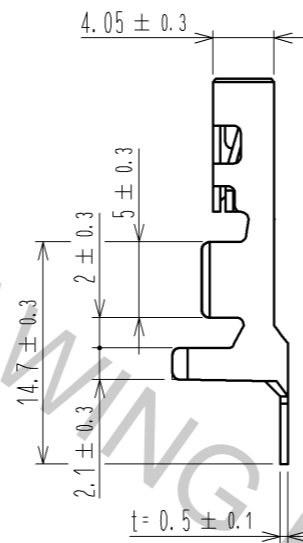
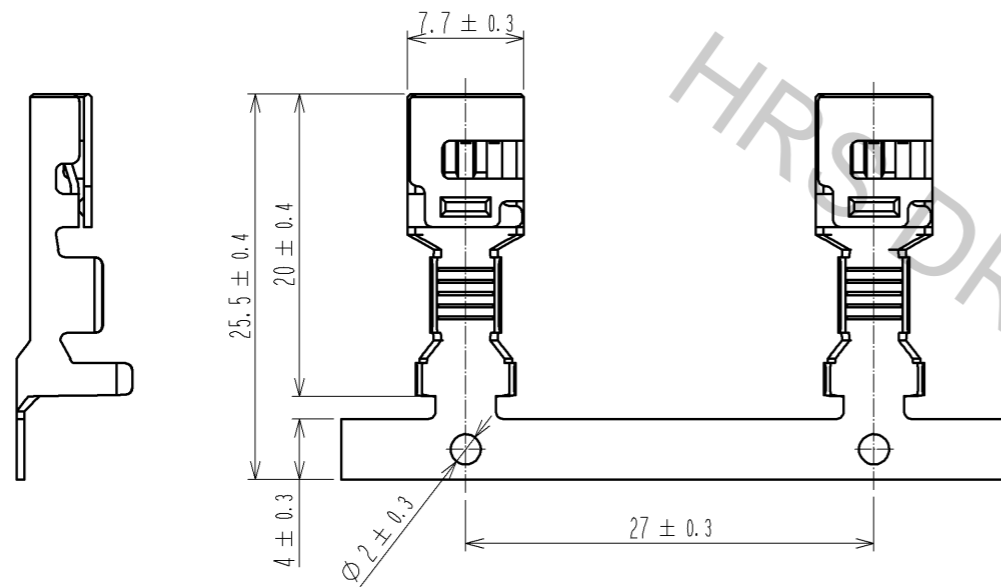
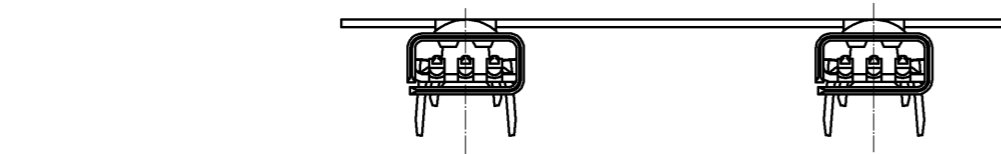
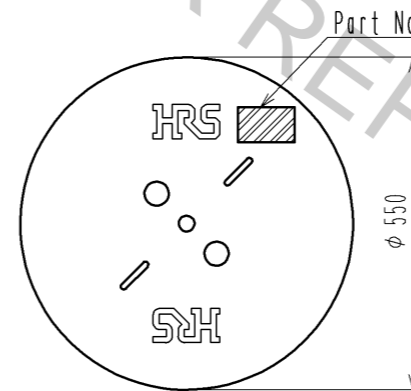

Part No. Label

Detail of part No. Label

HRS		検査
品名コード	CL680-3014-9	
品名	DF60-1012SCFA	
数量	900	
仕様		
LOT No.		
継ぎ目		
Section		Inspection
Lot No.		
Specification		
Quantity		
Part No.		
Code No.		

NOTE 1. 1RL:900 Contacts.

2 Style of Reel and Box Shows in Figure.

3. Please be sure to check the form of crimping using a cable. When you adjust Applicator.

NO.	MATERIAL	FINISH . REMARKS	NO.	MATERIAL	FINISH . REMARKS		
			1	COPPER ALLOY	Contact Area : Au Plating 0.2μm min Under Plating : Ni Plating 1μm min		
UNITS mm		SCALE 2 : 1	COUNT 	DESCRIPTION OF REVISIONS	DESIGNED	CHECKED	DATE
HRS	HIROSE ELECTRIC CO., LTD.	APPROVED : OM. MIYAMOTO	12.10.09	DRAWING NO.	EDC3-341029-00		
		CHECED : SZ. ONO	12.10.09	PART NO.	DF60-1012SCFA		
		DESIGNED : TH. YOSHIZAWA	12.10.09	CODE NO.	CL680-3014-9-00		
		DRAWN : TH. YOSHIZAWA	12.10.09				