

# Aavid Confidential

THE INFORMATION CONTAINED IN THIS DRAWING IS THE SOLE PROPERTY OF AAVID, A THERMAL DIVISION OF BOYD CORPORATION. ANY REPRODUCTION IN PART OR AS A WHOLE WITHOUT THE WRITTEN PERMISSION OF AAVID, A THERMAL DIVISION OF BOYD IS PROHIBITED.

THIS DRAWING IS CONTROLLED BY A CAD MODEL. IF IN DOUBT, PLEASE ASK.

### REVISION HISTORY

REV	ZONE	REASON FOR CHANGE	REVISED BY	REV DATE	APPROVED BY	DATE APPROVED
A	-	RELEASE TO PROTOTYPE	Kelly	5/8/2019	Jim	5/9/2019
B	-	CAHNGE DESCRIPTION	Sam	9/19/2019	Jim	9/19/2019

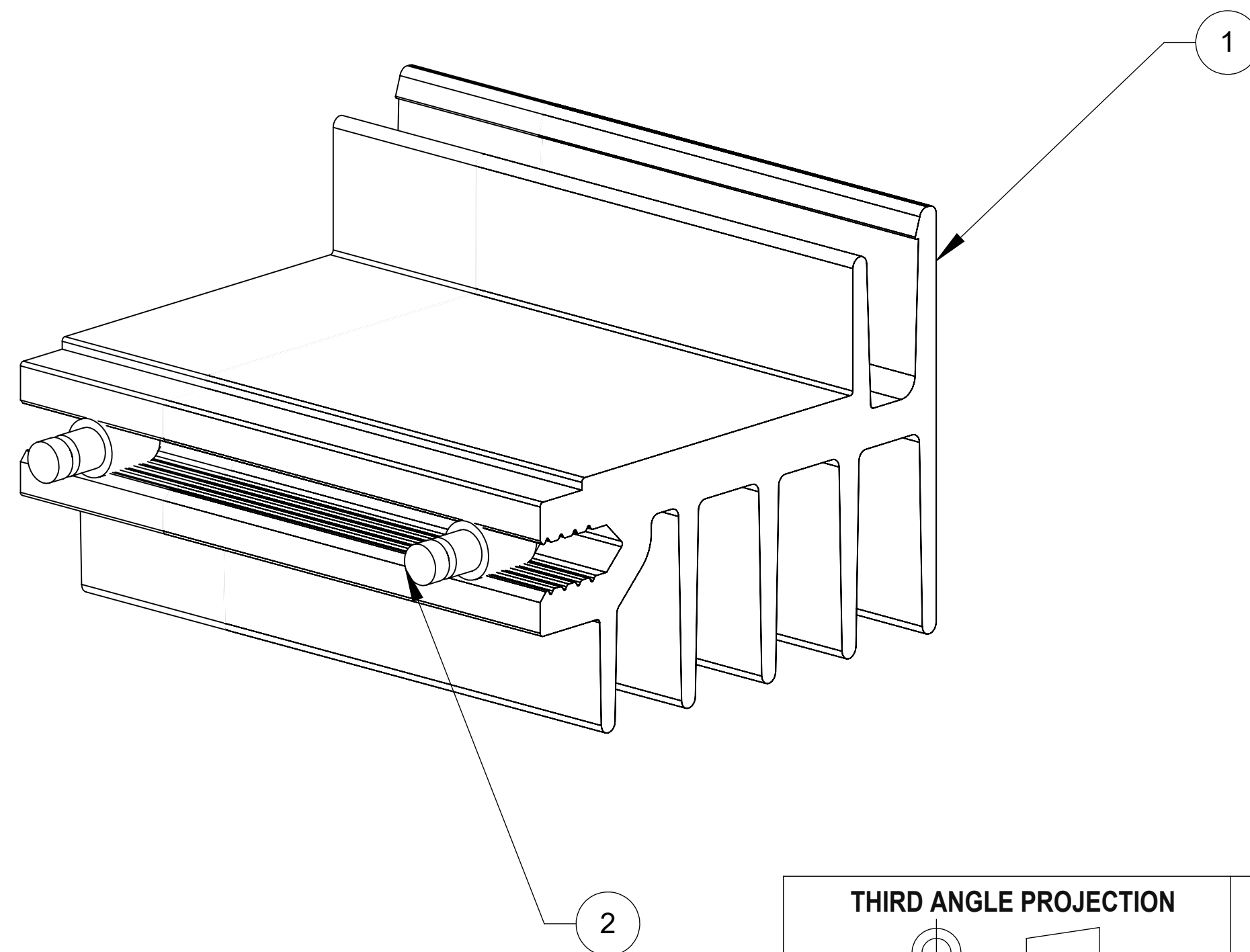
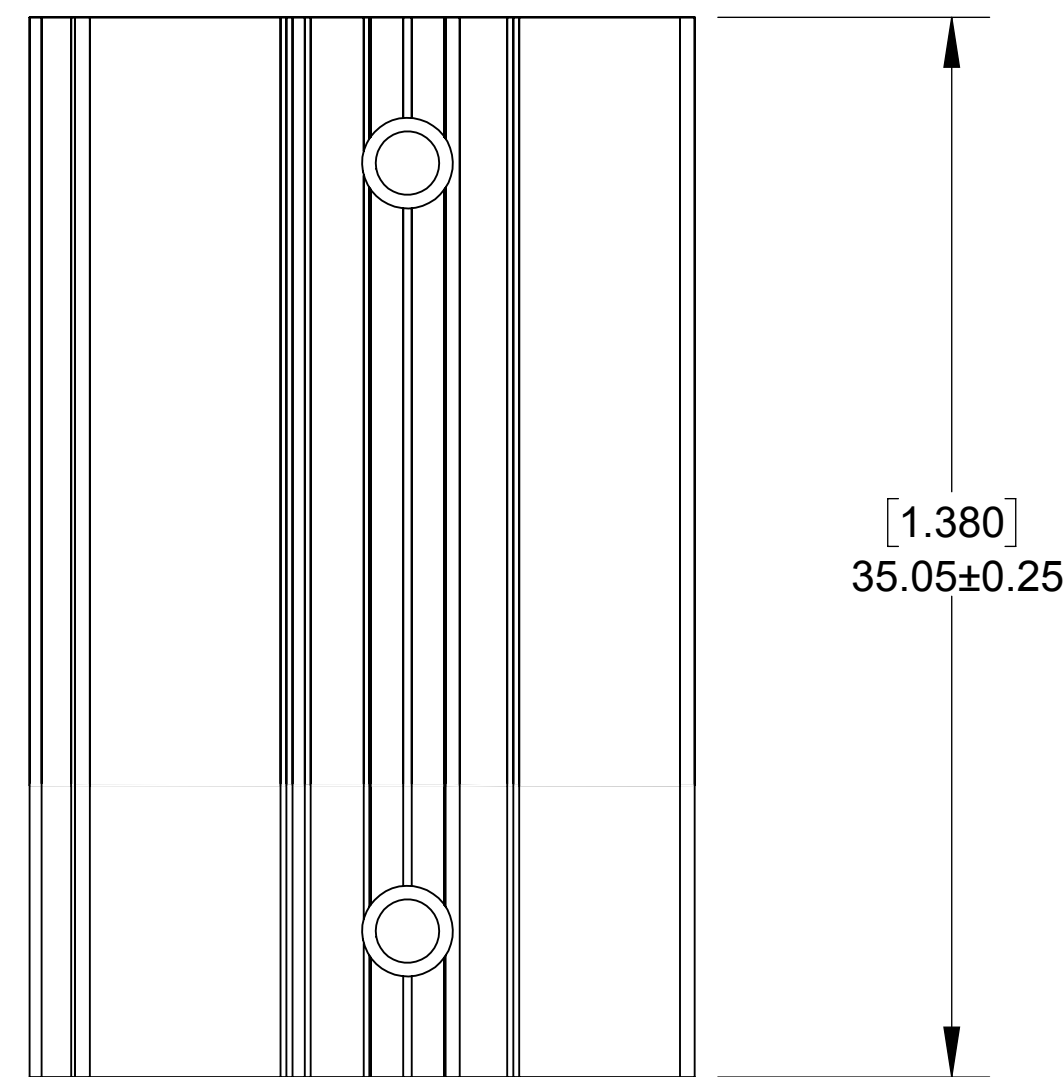
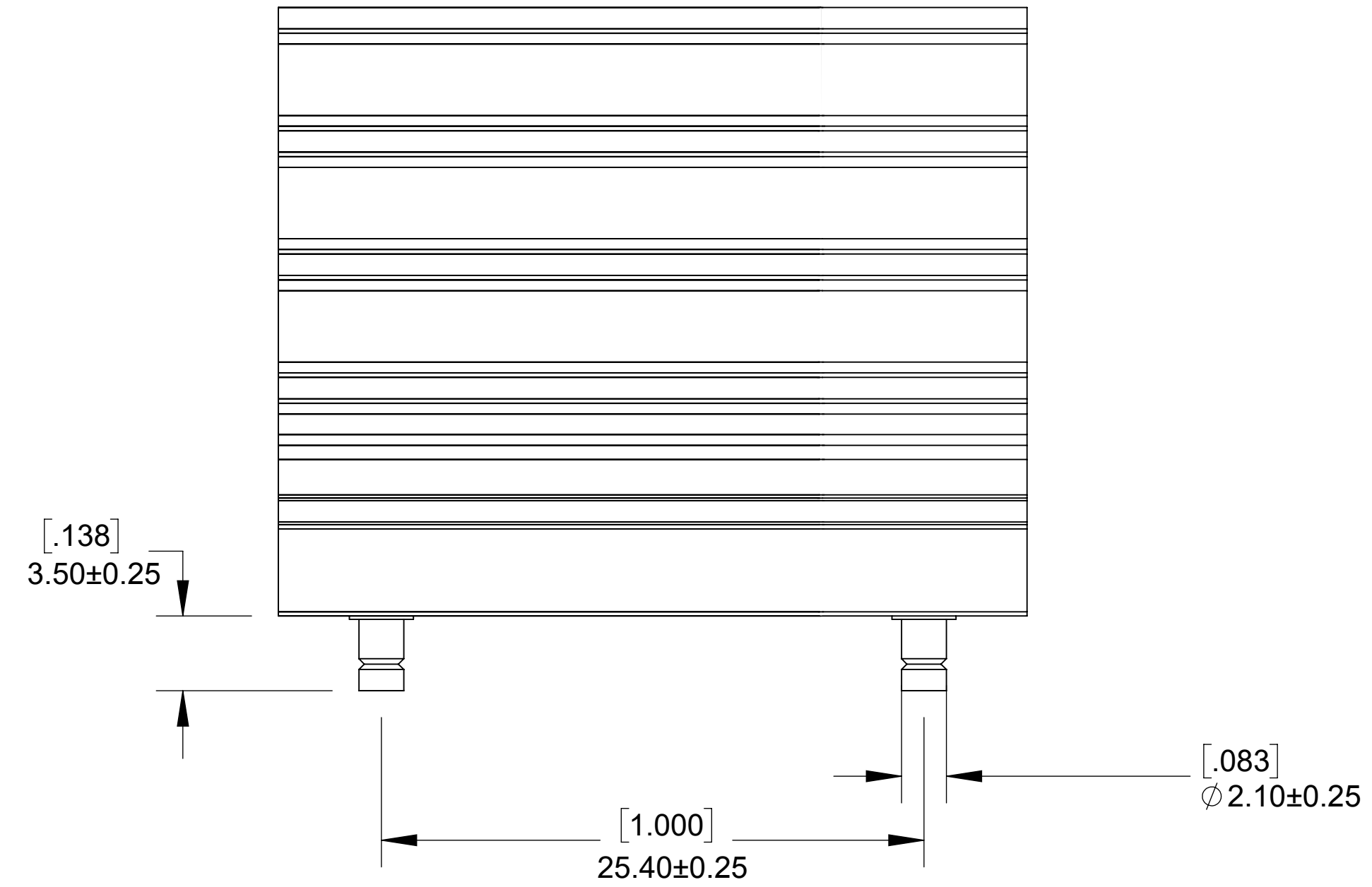
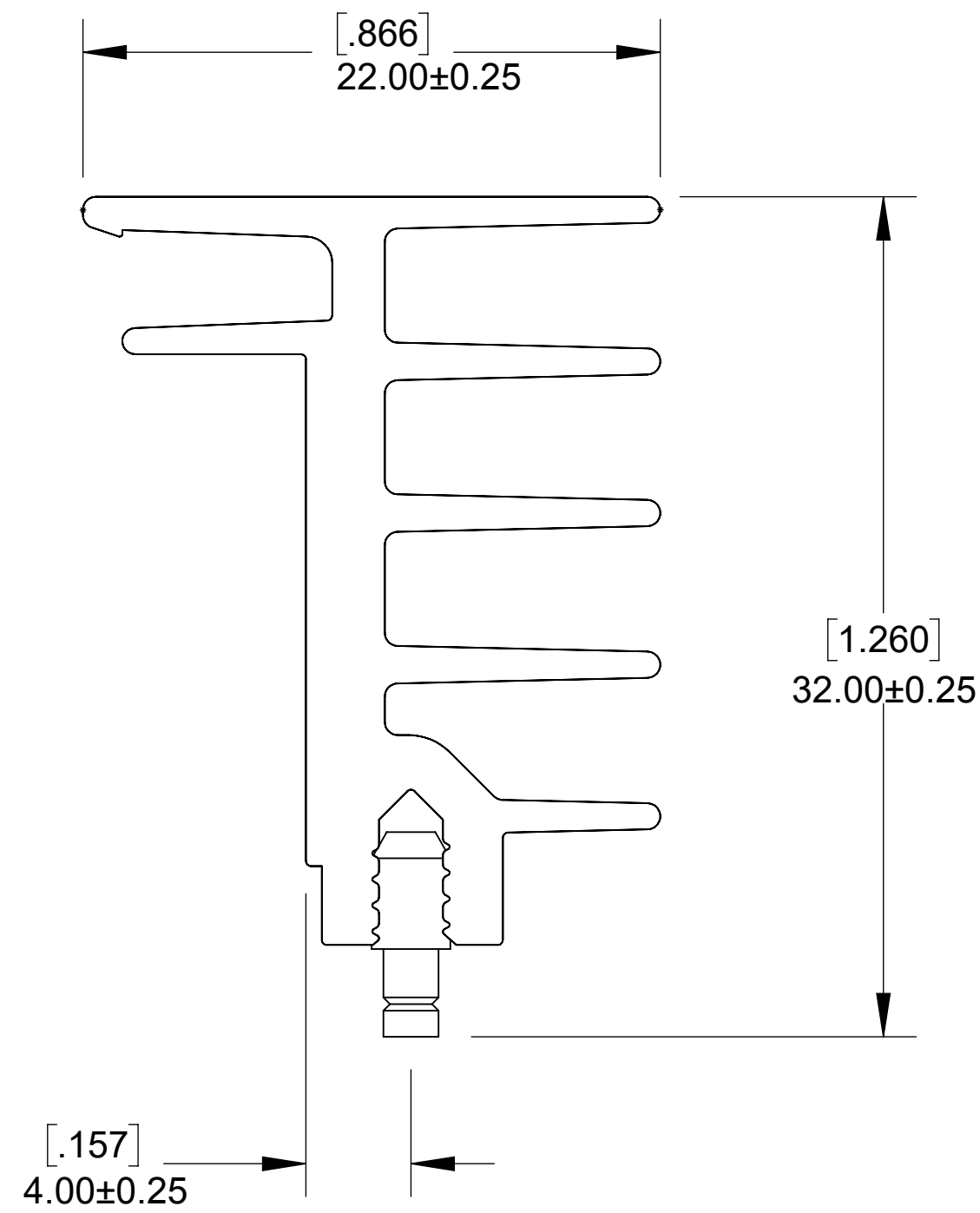

- NOTES:  
 1.) SEE CAD MODEL.  
 2.) PINS ARE SPACED 1 INCH APART CENTER TO CENTER.

- NOTES:  
 1. 未注尺寸公差参考CAD图档  
 2. 钉子居中压进铝挤槽内  
 3. 散热片表面处理: 黑色阳极  
 4. 产品不允许有毛刺、脏污等不良

RoHS COMPLIANT  
PER AAVID SPEC ROHS - 9000

ITEM NO.	PART NUMBER	DESCRIPTION	QTY.
1	78265	HEAT SINK CUT TO 1.380"	1
2	406060	PIN, SHOULDER, .118X0.307, PLTDG	2

<b>THIRD ANGLE PROJECTION</b> 				1 Aavid Circle, Laconia, NH 03246, USA <a href="http://www.boydcorp.com/aavid">www.boydcorp.com/aavid</a>		DIVISION <b>LC</b>	
PART TYPE IS <b>MACHINED</b> DIMENSIONS ARE IN mm [INCH] TOLERANCES UNLESS OTHERWISE SPECIFIED X± 0.380 [X± 0.015] .X± 0.250 [XX± 0.01] .XX± 0.125 [XXX 0.005] Angle 1° REMOVE ALL BURRS BREAK SHARP EDGES .13 - .38 [005 - .015] PART TO BE FREE OF DIRT, OIL, OR DEBRIS 0.8/MACHINED SURFACES		DESCRIPTION <h2>M49138B021000G</h2>				SIZE <h2>D</h2>	
DRAWN BY <b>Sam Zeng</b>		DATE <b>9/19/2019</b>		MATERIAL <b>AL6063-T5</b>			
CHECKED BY <b>Jim Liu</b>		DATE <b>9/19/2019</b>		FINISH <b>BLACK ANDOIZE</b>			
APPROVED BY <b>Jim Liu</b>		DATE <b>9/19/2019</b>		SHEET <b>1 of 1</b>		SCALE <b>NONE</b>	
				PART NUMBER <b>665882</b>		REV <b>B</b>	