

PRODUCT DATA DRAWING

REVISION HISTORY			
REV	DESCRIPTION	DATE	APPROVED
-	NRN 44451	12/19	STW
A	DCN 49641	02/20	BNK

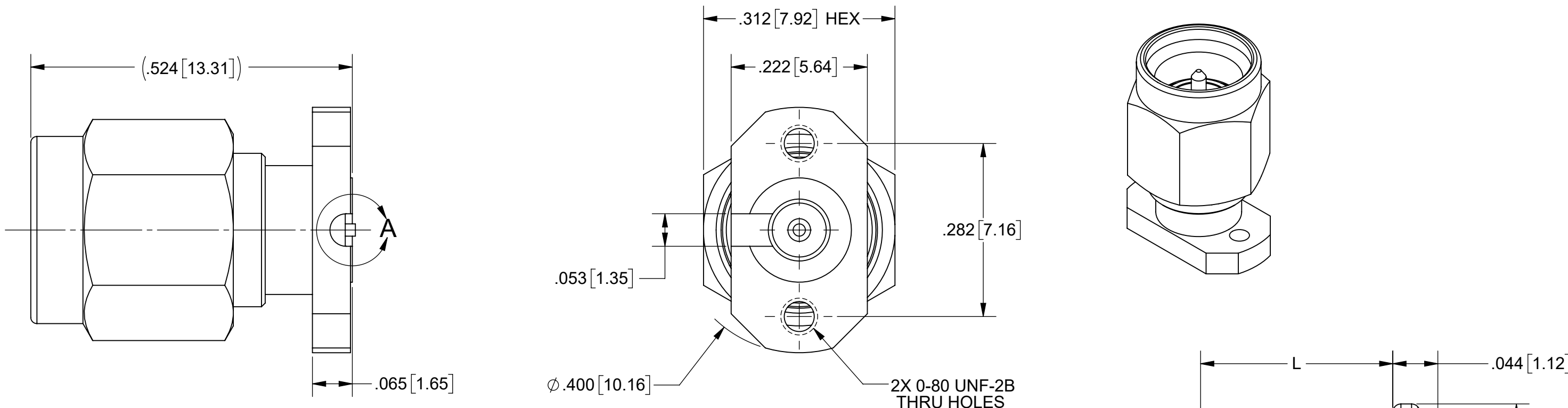

MATERIAL:

- BODY & COUPLING NUT:** STAINLESS STEEL PER AMS-5640, ALLOY UNS S30300, TYPE 1; OR ASTM A582 TYPE 303, COND. A
- LOCK RING & CONTACT:** BERYLLIUM COPPER PER ASTM B196, ALLOY No. UNS C17300, TD04
- INSULATOR:** PTFE PER ASTM D1710, TYPE I, GRADE 1, CLASS B
- GASKET:** SILICONE RUBBER PER A-A-59588, CLASS 2B, GRADE 60/70

FINISH:

- BODY & COUPLING NUT:** PASSIVATED PER AMS-2700
- CONTACT:** GOLD PER ASTM B488, TYPE II, CODE C, CLASS 1.27, OVER NICKEL PER AMS-QQ-N-290, CLASS 1, .00005" MIN.

PERFORMANCE:

- IMPEDANCE:** 50 OHMS
- FREQ. RANGE:** DC TO 26.5 GHz

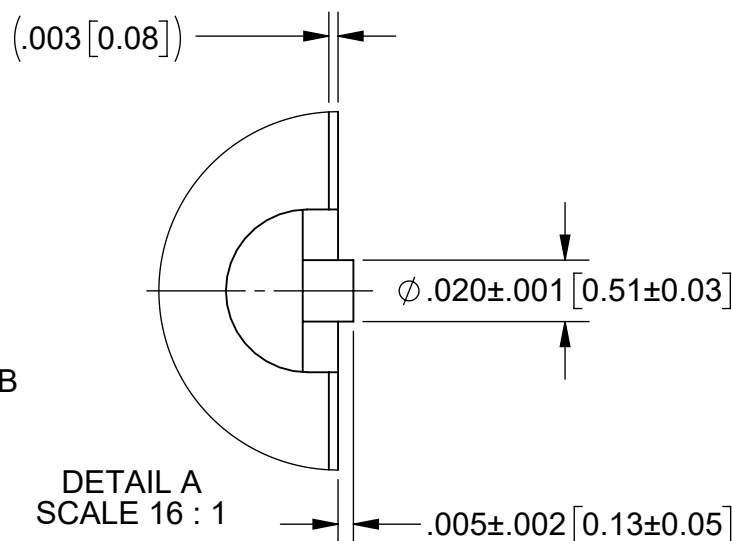

SV P/N	DESCRIPTION	PCB THICKNESS	L
SF2911-60973	NO SCREWS	.005 TO .373	N/A
SF2911-60973-1S	INCL. TWO .188 SCREWS	.032 TO .123	.188
SF2911-60973-2S	INCL. TWO .250 SCREWS	.094 TO .185	.250
SF2911-60973-3S	INCL. TWO .438 SCREWS	.282 TO .373	.438

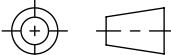
MATERIAL: SEE NOTES	DIMENSIONS ARE IN INCHES TOLERANCES: FRACTIONAL: ±1/64 ANGULAR: X° ±1'0" X'X' ±15'	UNLESS OTHERWISE SPECIFIED 1) ALL DIMENSIONS ARE IN INCHES (MILLIMETERS) 2) ALL DIMENSIONS ARE AFTER PLATING. 3) BREAK CORNERS & EDGES .005 R. MAX. 4) CHAM. 1ST & LAST THREADS. 5) SURFACE ROUGHNESS 63-MIL-STD-10. 6) DIA.'S ON COMMON CENTERS TO BE CONCENTRIC WITHIN .005 T.I.R. 7) REMOVE ALL BURRS	 www.svmicrowave.com TITLE: SMA PLUG 2 HOLE FLANGE MOUNT
FINISH: SEE NOTES	DECIMAL: X ±.030 .XX ±.010 .XXX ±.005	INTERPRET DIMENSIONS AND TOLERANCES PER ASME Y14.5M - 1994	
SURFACE AREA: N/A	THIRD ANGLE PROJECTION	DRAWN: SJ 11/22/19	SIZE DWG. NO. B SF2911-60973-XS
PROPRIETARY THE INFORMATION CONTAINED IN THIS DRAWING IS THE SOLE PROPERTY OF SV MICROWAVE, INC. ANY REPRODUCTION IN PART OR AS A WHOLE WITHOUT THE WRITTEN PERMISSION OF SV MICROWAVE, INC IS PROHIBITED.		CHECKED: BNK 11/22/19	SCALE: 6:1
		APPROVED: BNK 11/22/19	SHEET 1 OF 1