

REVISION			
REV	DESCRIPTION	DATE	APPROVED
A	OUTLINE DRAWING	11/01/19	

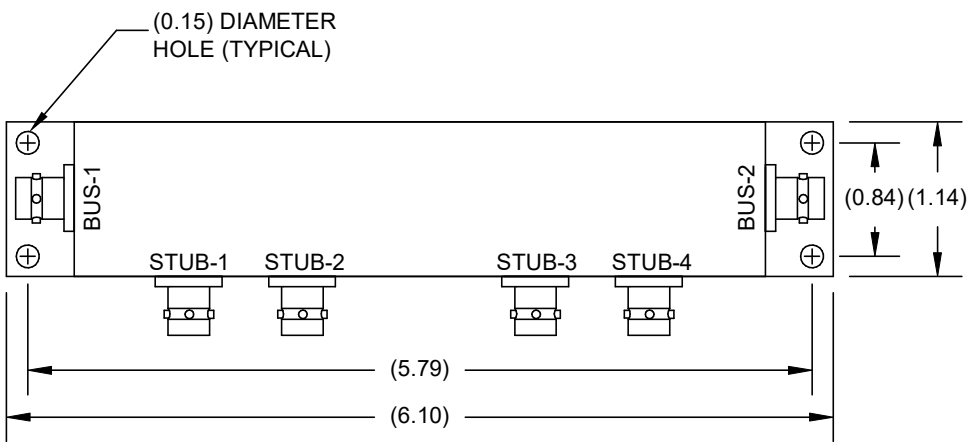
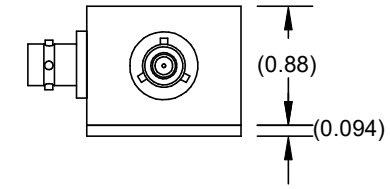
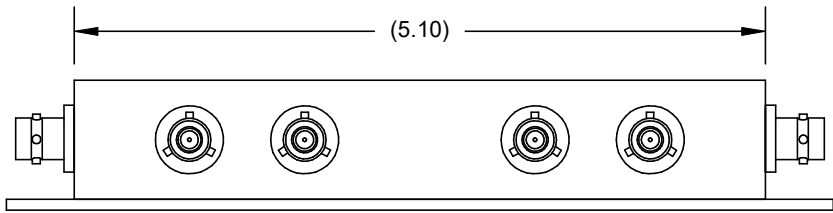
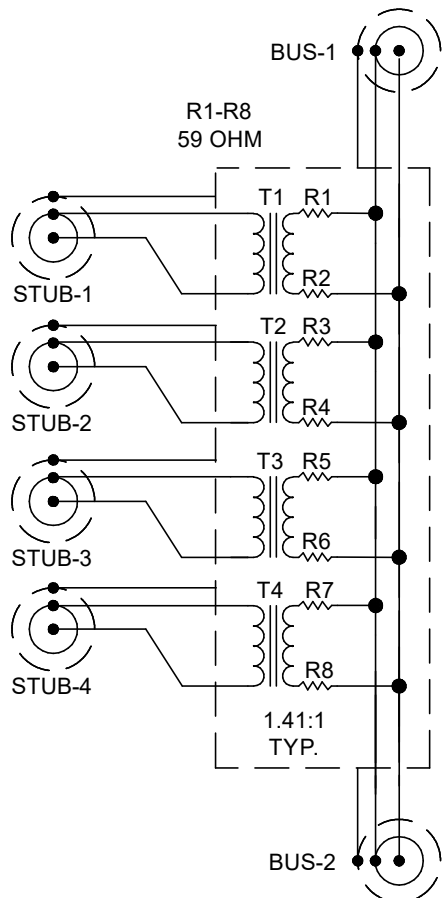

**1.0 ELECTRICAL SPECIFICATIONS: IAW MIL-STD-1553B**

- 1.1 DROOP 20% MAXIMUM
- 1.2 OVERSHOOT AND RINGING +/- 1.0V PK-PK
- 1.3 TRANSFORMER RATIO (T1-T4) 1.41CT:1CT
- 1.4 FAULT PROTECTION (R1-R8) 59 ohm +/- 1%, 2WATT PER MIL-R-39007
- 1.5 COMMON MODE REJECTION -55 dB @ 1 MHz

**2.0 MECHANICAL SPECIFICATIONS:**

- 2.1 HOUSING: DIE CAST A360 ALUMINUM ALLOY  
CLEAR ANODIZED AND PAINTED WITH TEXTURED  
BAKED ENAMEL, COLOR BLUE
- 2.2 BASE PLATE: T6061 ALUMINUM, SATIN FINISH
- 2.3 CONNECTOR B770 OR EQUIVALENT
- 2.4 MATING CONNECTOR TRB PLUG PL75 OR EQUIVALENT

**3.0 ENVIRONMENTAL:**

- 3.1 OPERATING TEMPERATURE -55 C TO + 125 C

CAD SYSTEM DRAWING - DO NOT REVISE MANUALLY			
UNLESS OTHERWISE SPECIFIED ALL DIMENSIONS ARE IN INCHES		SIGNATURE	DATE
DECIMALS--X-- ± N/A		DRAWN BY:	
DECIMALS--XX-- ±0.10		CHECKED BY:	
DECIMALS--XXX-- ±N/A		APPROVED ENGINEERING:	
ANGLES-----±N/A		APPROVED MANUFACTURING:	
NOTE: ALL DIMENSIONS ARE NOMINAL		CUSTOMER APPROVAL	
DASH	NEXT ASSY	USED ON	
APPLICATION		CAGE CODE: 14949	
TITLE		4 STUB NON TERMINATED BUS COUPLER ASSEMBLY	
SIZE	DRAWING NUMBER:		
D	TEBC-1004		
SCALE: NTS	DO NOT SCALE DRAWING	SHEET 1 OF 1	