

THE INFORMATION CONTAINED IN THIS DRAWING IS THE SOLE PROPERTY OF L-COM, INC. ANY REPRODUCTION IN PART OR WHOLE WITHOUT THE WRITTEN PERMISSION OF L-COM, INC. IS PROHIBITED.

REVISIONS			
REV	DESCRIPTION	DATE	APPROVED
A	REV A DRAWING RELEASED	05/16/18	S.LI

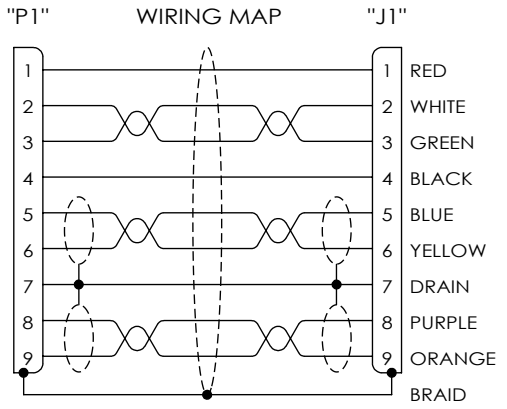
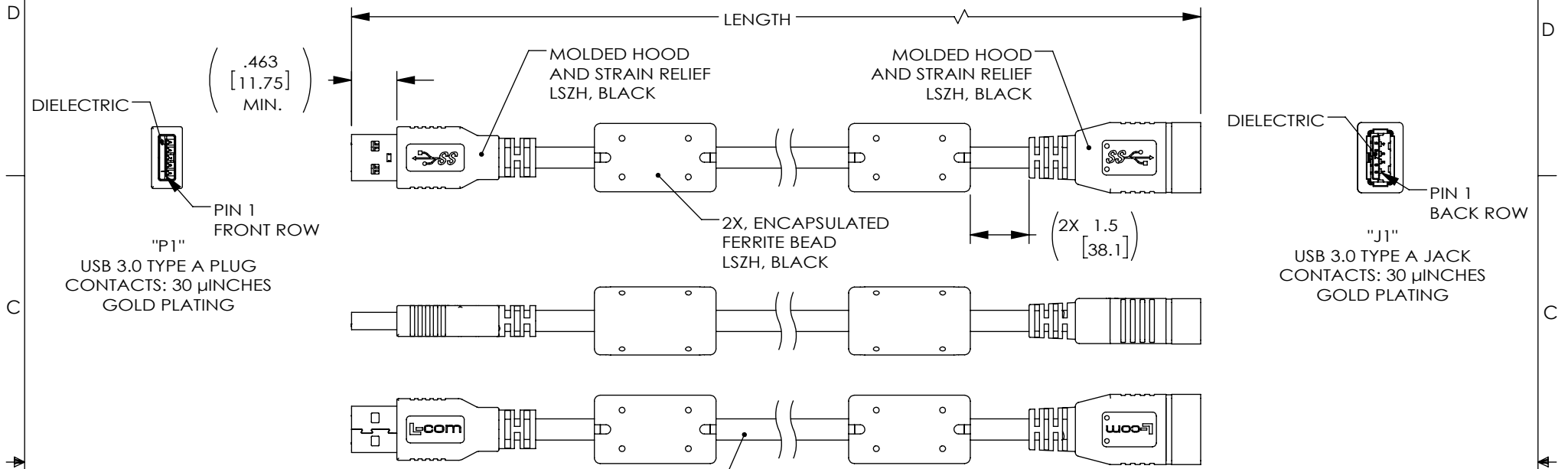

UL STYLE 21551, 2X, TWISTED PAIR, 30AWG WITH ALUM/POLY FOIL SHIELD AND DRAIN WIRE. ONE UNSHIELDED TWISTED PAIR, 30AWG. 2 COND., 24AWG. OVERALL BRAID SHIELD, 65% JACKET: LSZH, BLACK(NOM. DIA. .217[5.5])

PART NUMBER	LENGTH METERS [FEET]
U3A00086-03M	0.3 [.98]
U3A00086-05M	0.5 [1.64]
U3A00086-1M	1.0 [3.28]

- NOTES:**
1. CABLE ASSEMBLY SHALL BE TESTED FOR CONTINUITY.
 2. CABLE ASSEMBLY SHALL HAVE 360° SHIELD TERMINATION.
 3. CABLE ASSEMBLY MUST MEET USB 3.0 REQUIREMENTS.
 4. CABLE ASSEMBLY SHALL BE INDIVIDUALLY PACKAGED IN ACCORDANCE WITH L-COM SPECIFICATION PS-0031.

REGULATORY COMPLIANCE:
CE2011/65/EU(RoHS DIRECTIVE)

UNLESS OTHERWISE SPECIFIED, DIMENSIONS ARE IN INCHES [mm] OVERALL CABLE LENGTH TOLERANCE: ≤12 [305] = +1 [25] / -0 >12 [305] ≤60 [1524] = +2 [51] / -0 >60 [1524] ≤120 [3048] = +4 [102] / -0 >120 [3048] ≤300 [7620] = +6 [152] / -0 >300 [7620] = +3% / -0%	APPROVALS	DATE		50 PIN STREET NORTH ANDOVER, MA 01845
	DRAWN BY S.LI	01/23/18		CATEGORY
ALL OTHER DIMENSIONAL TOLERANCES: .X = ±.2 [5.08] .XX = ±.02 [1.51] .XXX = ±.005 [1.3]	CHECKED BY B.ZHANG	01/23/18	PRODUCT DESCRIPTION	
PROJECTION	APPROVED BY S.PAN	01/23/18	CA, USB3.0 TYPE A/AF LSZH W/FERRITE	
	CONFIGURATION DETAILS OF UNDIMENSIONED FEATURES MAY VARY	COLOR VARIATIONS MAY OCCUR	SIZE A	FSCM NO. 43321
			DWG. NO. U3A00086	REV. A
			SCALE: NONE	CAD FILE: U3A00086.SLDDRW
				SHEET 1 OF 1