

Size #23 Crimp Contacts for Series 80 High-Speed Mighty Mouse Connectors



Series 80 High
Speed Mighty
Mouse

SIZE #23 CRIMP CONTACTS

Standard size #23 contacts accept #22 to #28 AWG wire. Choose "small bore" versions for #26 to #30 AWG wire. Contacts are bulk packaged. Terminate with standard M22520 crimper with special positioner.

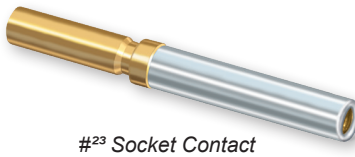
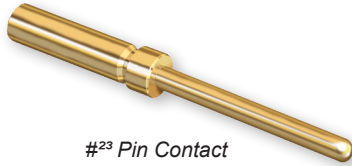

| Contact Type | Wire Size | Material | Part Number | Ø A | | Color Band | Tool Code |
|--------------|-----------|----------|----------------|-------------|-------------|------------|-----------|
| | | | | In. | mm. | | |
| Pin | #22 – #28 | BeCu | 809-001 | .0335-.0355 | 0.851-0.902 | None | A, C |
| Pin | #26 – #30 | BeCu | 809-042 | .0229-.0245 | 0.582-0.622 | Blue | A, D |
| Socket | #22 – #28 | BeCu | 809-002 | .0335-.0355 | 0.851-0.902 | None | A, C |
| Socket | #26 – #30 | BeCu | 809-043 | .0229-.0245 | 0.582-0.622 | Blue | A, D |

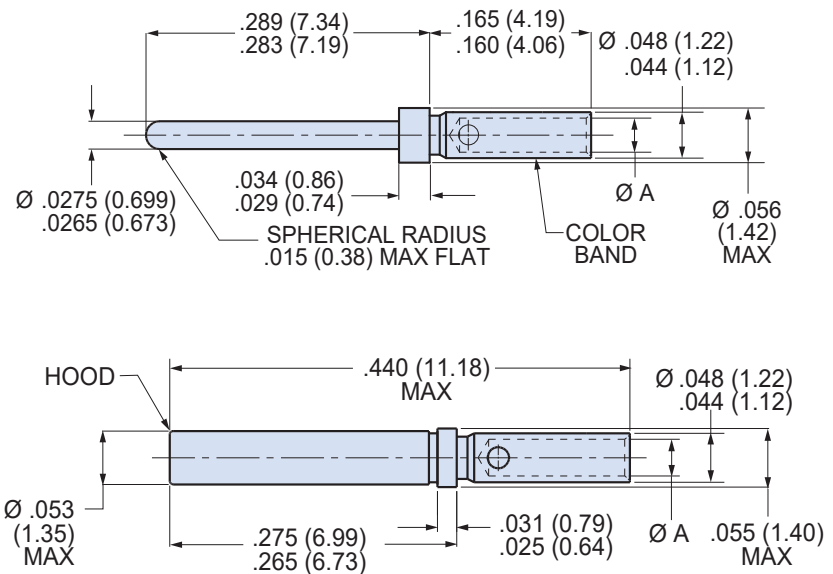

| Crimp Tensile Strength | | |
|--|----------------------------------|---------------------------|
| Values are in pounds and are minimums. | | |
| Wire Gage | Silver or Tin Coated Copper Wire | Nickel Coated Copper Wire |
| #22 | 12 | 8 |
| #24 | 8 | 6 |
| #26 | 5 | 3 |
| #28 | 3 | 2 |
| #30 | 1.5 | 1.5 |

Material and Finish

Beryllium copper alloy per ASTM B196 or B197, 550 microinches gold plated per ASTM B 488 over nickel underplate. Crimp area may have less plating.
Thermocouple contacts: alumel or chromel alloy, unplated, per ANSI 96.1
Socket contact hood: stainless steel, passivated per AMS-QQ-P-35.

Specifications

Current Rating: 5 Amps maximum
Voltage Drop (at 5 Amps and 25° C): 70 millivolts maximum
Temperature Range: -65° to + 200° C
Socket Contact Minimum Separation Force: 0.5 ounces

Crimp Tools and Insertion/Removal Tools

Crimper: 809-015
Positioner: 809-005 (standard). Use P/N 809-057 for small bore contacts 809-065 and 809-066
Standard Insertion/Removal Tool: 809-088

Dimensions in Inches (millimeters) are subject to change without notice.



Size #23 Crimp Contact Termination, Installation and Removal Instructions for Series 80 High-Speed Mighty Mouse Connectors

HOW TO TERMINATE, INSTALL AND REMOVE SIZE #23 CONTACTS

1 Set Up Crimp Tool. Install proper positioner into crimp tool. The label on the positioner shows the proper tool setting for each wire size. Turn the adjustment wheel to the correct setting.

2 Strip Wire. Remove wire insulation, taking care to avoid nicking or cutting wire strands. Strip wire to length shown.

3 Insert wire into contact. The wire should be visible in the inspection hole.

4 Insert contact into crimp tool as shown. Make sure that the contact is fully inserted into the tool. Squeeze handle completely. The ratchet mechanism will not allow a partial crimp. Release handle and remove contact.

5 Inspect crimped contact. Wire should be fully inserted and the crimp should be uniform in appearance.

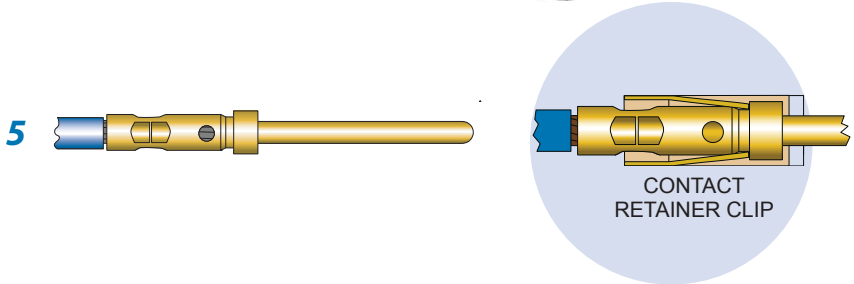
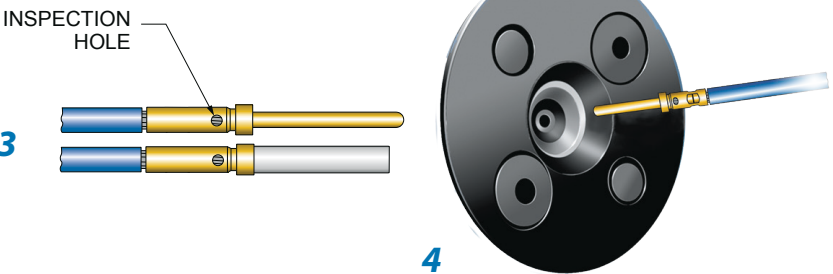
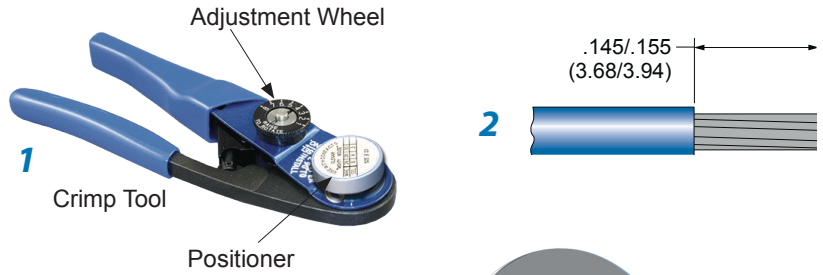

Insertion/Extraction Tool 809-088

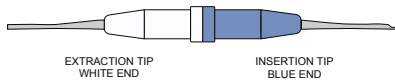

6 Install contact into connector. Push the contact through the rear grommet until the contact locks into place. This can usually be done by hand without the need for a tool. If the wire gage is #26 or smaller, a tool is helpful. There are two techniques for installing contacts with a tool. One method is to push the contact in by hand, then use the tool to finish the insertion. The other method is to position the insertion tip against the contact shoulder, then insert the contact. Use insertion/extraction tool 809-088 to install contacts. Slide the wire into the groove on the blue end of the tool. Slide the tool tip up the contact until it touches the contact shoulder. **USE CARE TO AVOID DAMAGING THE CONNECTOR.**

7 Contact Extraction. Use tool 809-088. The white end is used for contact extraction. First, push the wire into the groove of the metal tip. Slide the tip of the tool into the connector. Push the tool into the connector cavity until the tip bottoms in the connector. Avoid wiggling or rocking the tip. This may damage the cavity. A straight push is best. Pinch the wire between your finger and the white plastic grip and slide the tool and contact out of the connector. **Wire insulation diameter greater than 0.045 inches (1.14mm) is too large to work properly with the extraction tool. connector damage is possible.**

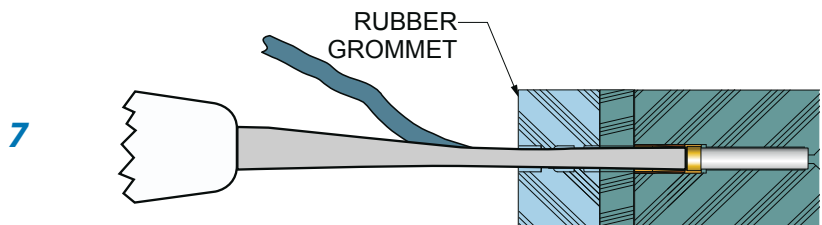
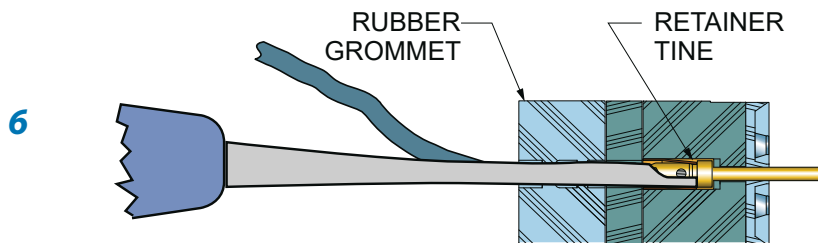

Dimensions in Inches (millimeters) are subject to change without notice.

Size #23 Crimp Contact Sealing Plugs and Tools for Series 80 High-Speed Mighty Mouse Connectors



Series 80 High
Speed Mighty
Mouse

GROMMET SEALING PLUGS

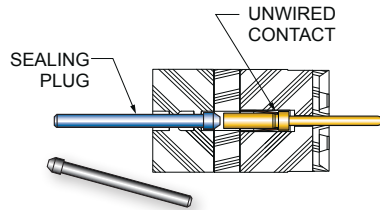

Grommet sealing plugs are used to seal unwired contact cavities. The size #23 sealing plug is specially designed to fit Glenair Series 80 grommets. After installing unwired contacts into unused cavities, insert knob end of sealing plug into grommet until it bottoms against the unwired contact per illustration. Install sealing plugs with standard contact insertion/extraction tools. The size #23 plug is polyphenylsulphone.

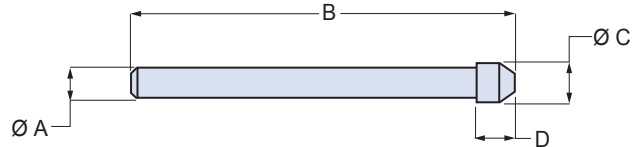

| Size | Color | Part Number | Military Part Number | Insertion/ Removal Tool | A Ref. | | B Ref. | | C Ref. | | D Ref. | |
|------|-------|----------------|----------------------|-------------------------|--------|------|--------|------|--------|------|--------|------|
| | | | | | in. | mm. | in. | mm. | in. | mm. | in. | mm. |
| #23 | Black | 809-155 | (None) | M81969/14-01 | .040 | 1.02 | .51 | 13.0 | .052 | 1.32 | .050 | 1.27 |

MINIATURE ADJUSTABLE CRIMP TOOLS



Standard M22520/2-01 crimper for use with standard size #23 Mighty Mouse contacts. Crimp tools perform precision eight indent crimps for gas-tight wire terminations and excellent tensile strength. Adjustment wheel has 8 settings. Ratchet mechanism prevents improper crimps. Use with bayonet-type positioners. Check calibration with M22520/3 gages. Length is 6.75 inches, weight is approx. 10 oz.

| Part Number | Military Part Number | Daniels Part Number | Tool Code |
|----------------|----------------------|---------------------|-----------|
| 809-015 | M22520/2-01 | AFM8 | A |

POSITIONERS FOR USE WITH MINIATURE ADJUSTABLE CRIMP TOOLS

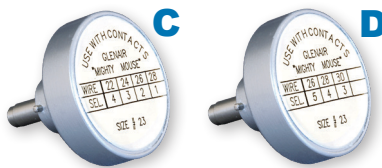

These bayonet-type positioners hold contacts at correct height for crimping with M22520/2 type miniature step adjustable tools, above. Face plate shows correct tool settings. "C" Positioner is for standard size #23 contacts. #22-#28 AWG. Use with 809-015 crimp tool. "D" Positioner is for small bore size #23 contacts. #26-#30 AWG. Use with 809-015 crimp tool.

| Figure | Part Number | Military Part Number | Daniels Part Number | Tool Code |
|--------|----------------|----------------------|---------------------|-----------|
| C | 809-005 | (none) | K1461 | C |
| D | 809-057 | (none) | (none) | D |

CONTACT INSERTION AND REMOVAL TOOL



Insertion/Extraction Tool for #23 Contacts. This tool features molded plastic grips and sturdy stainless steel tips. Blue/White molded handle.

| Size | Type | Part Number | Military Part Number | Daniels Part Number |
|------|----------------------|----------------|----------------------|---------------------|
| #23 | Insertion/Extraction | 809-088 | (None) | (None) |

Dimensions in Inches (millimeters) are subject to change without notice.