

PART NUMBER	PACK	HOOD SIZE
8655DMES2B13KLF	KIT	09

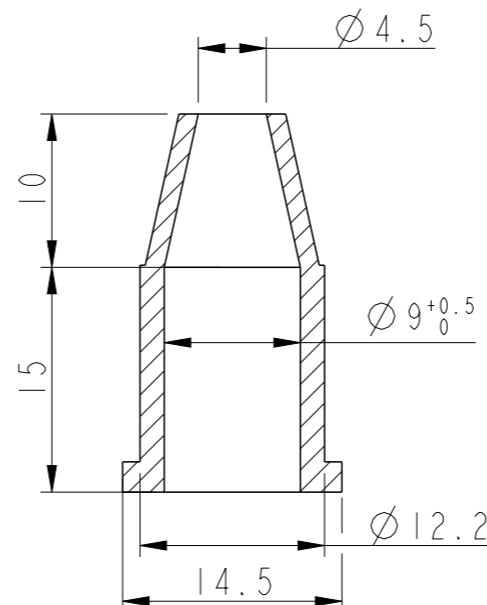
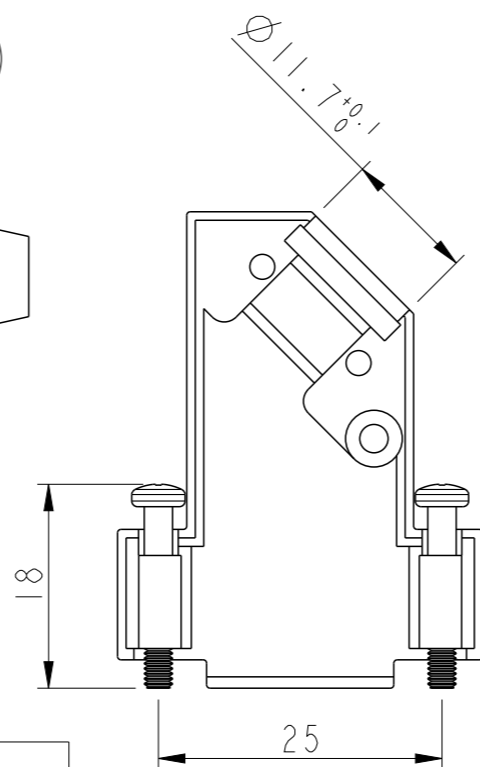
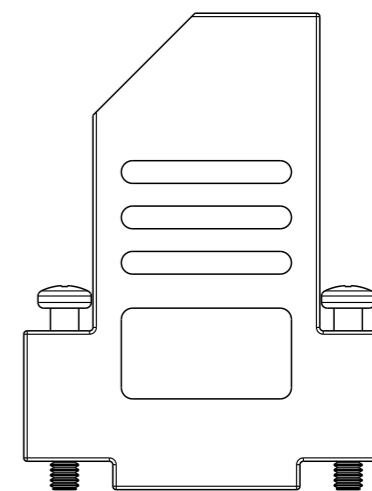
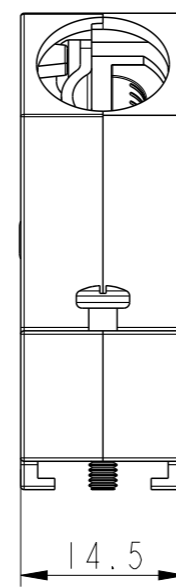
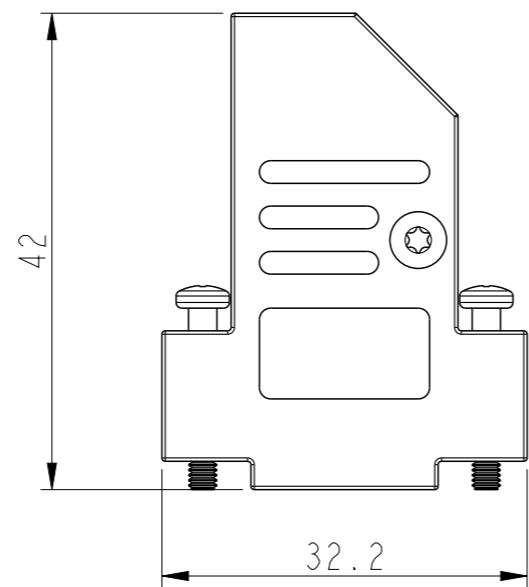
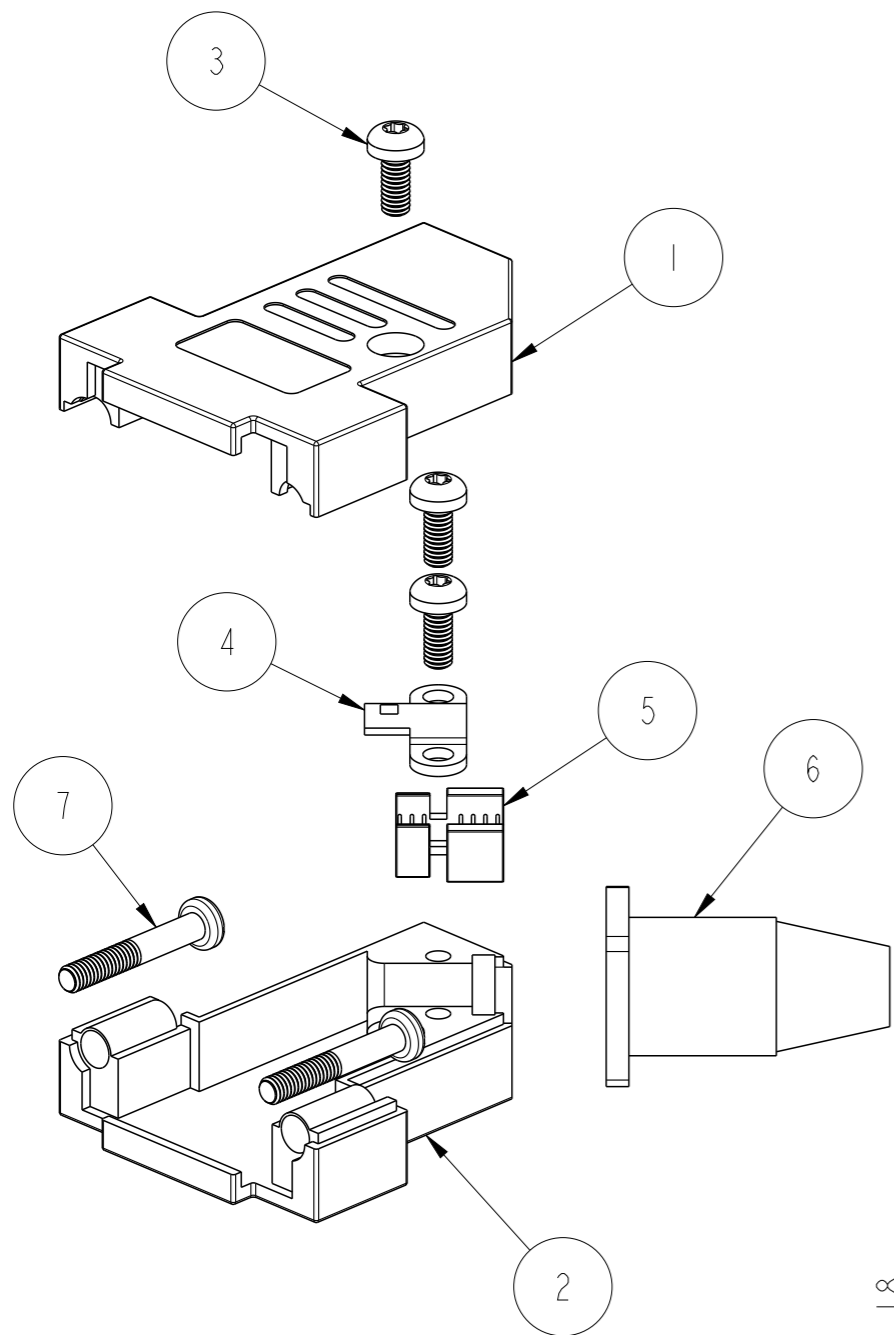

NOTES: (FOR EVERY SIZES)  
 1- OPERATING TEMPERATURE: -40°C TO +120°C  
 2- INDIVIDUAL KITS SEALED IN PLASTIC COVER IN UNASSEMBLED FORM.  
 BOM AS SHOWN IN TABLE

RoHS INFORMATION:  
 - THE LF PRODUCT MEETS EUROPEAN UNION DIRECTIVES AND OTHER COUNTRY REGULATIONS AS DESCRIBED IN GS+22-009  
 - THE PRODUCT IS NOT INTENDED TO BE EXPOSED TO A MANUFACTURING SOLDER PROCESS

ITEM NO.	QTY.	PART DESCRIPTION
1	1	D45SL09-UPPER COVER
2	1	D45SL09-LOWER COVER
3	3	M2.5X6 SCREW
4	1	CABLE CLAMP
5	1	PLASTIC INSERT DTSL09 -TOP & SIDE
6	1	RUBBER GROMMET
7	2	UNC4-40x18 JACKSCREW

spec ref	-	dr	Dipu Joseph	2020/09/14	projection	mm	size	A3	scale	1:1	
tolerance std	ISO 406 ISO 1101	eng	Detouillon, Da	2020/11/17			ecn no	-	rel level	Released	
TOLERANCES UNLESS OTHERWISE SPECIFIED		chr	-	-			product family	-	rel level	Released	
surface	linear	appr	Wollin, Severi	2020/11/13			dwg no	8655DMx2B13KLF		rev	A
ISO 1302	angular	0°	±2°	cat. no.	-	Product - Customer Drw	sheet 1 of 4				

PART NUMBER	PACK	HOOD SIZE
8655DMAS2B13KLF	KIT	15

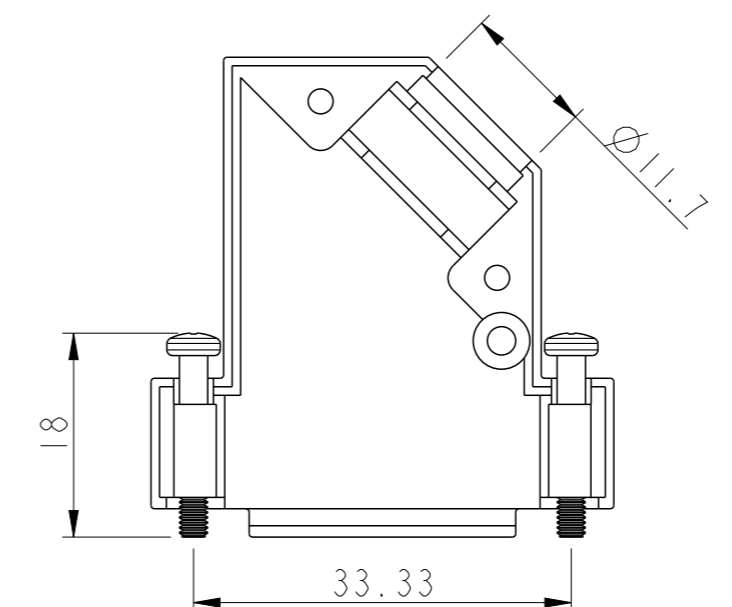
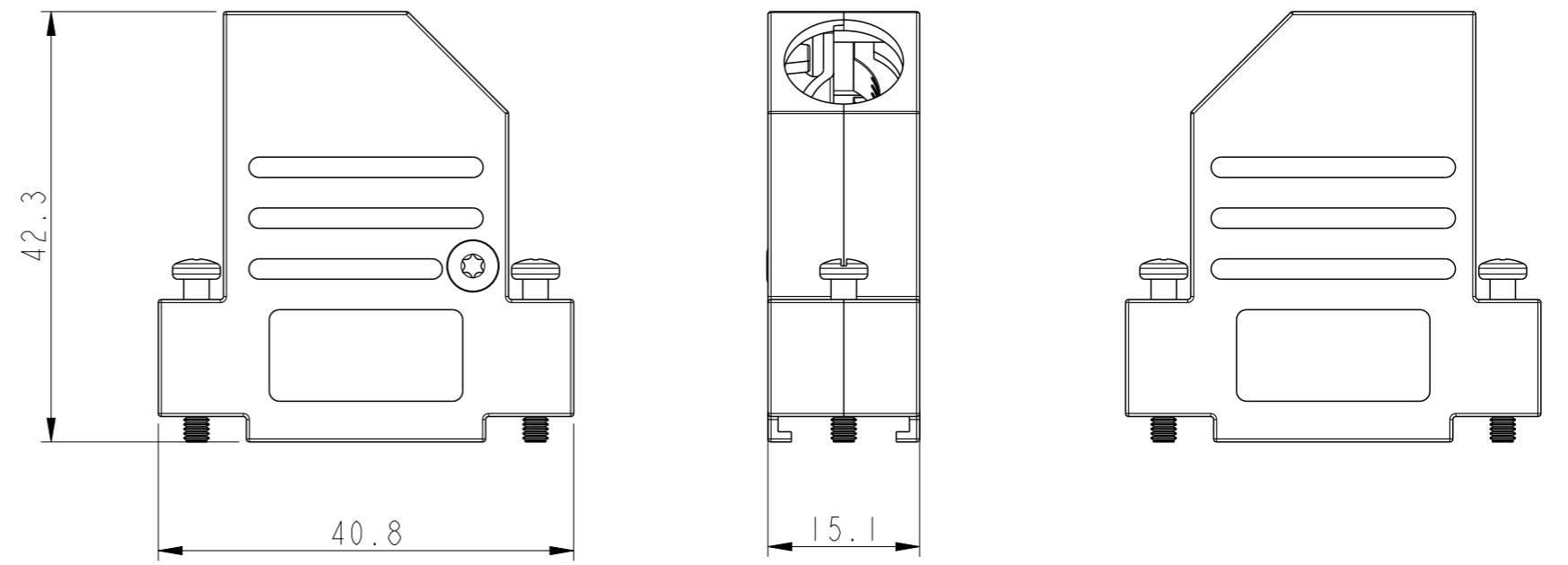
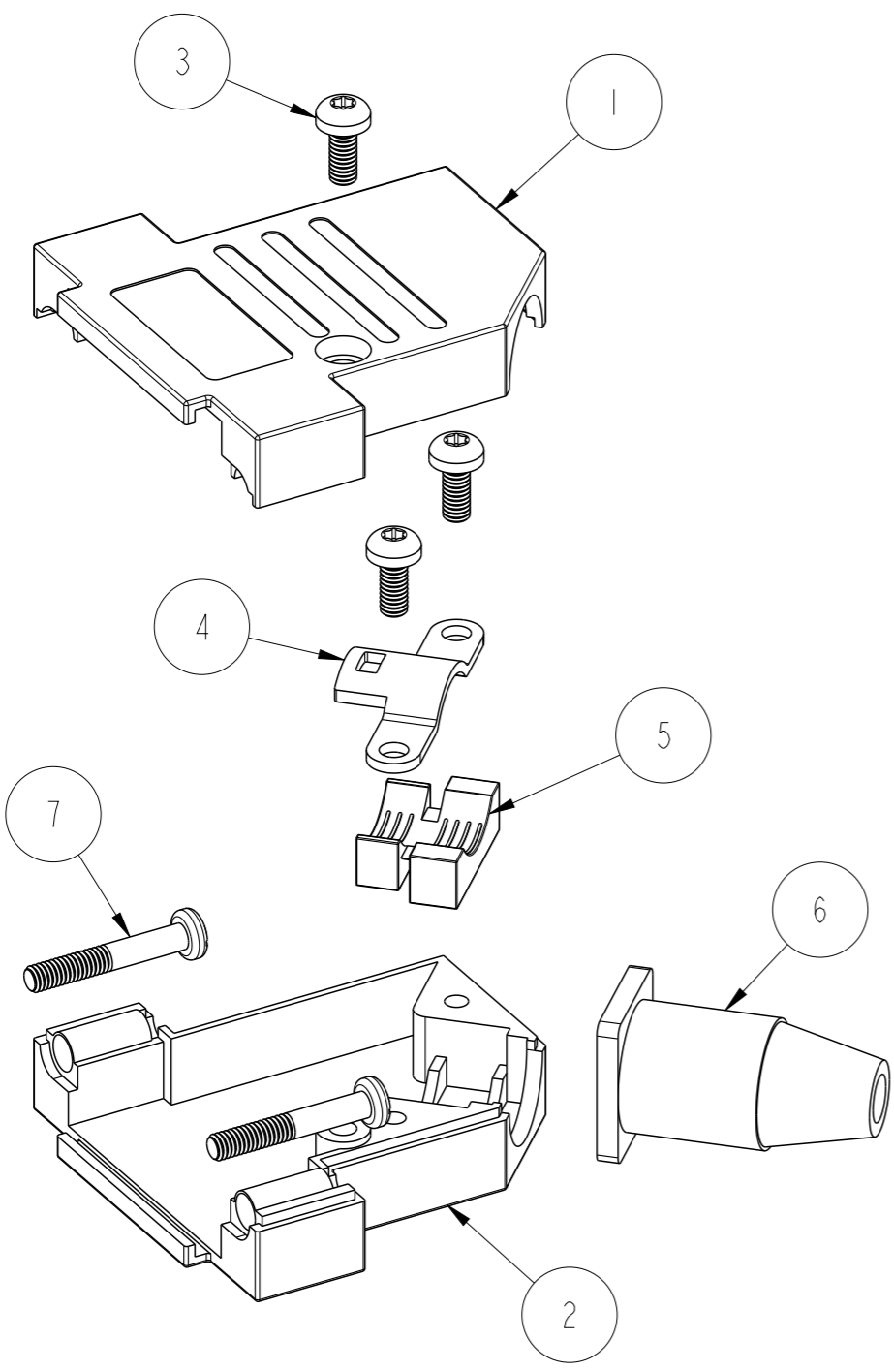

ITEM NO.	QTY.	PART DESCRIPTION
1	1	D45SL15-UPPER COVER
2	1	D45SL15-LOWER COVER
3	3	M2.5X6 SCREW
4	1	CABLE CLAMP
5	1	PLASTIC INSERT
6	1	RUBBER GROMMET
7	2	UNC4-40x18 JACKSCREW

spec ref	-	dr	Dipu Joseph	2020/09/14	projection	mm	size	A3	scale	1:1
tolerance std	ISO 406 ISO 1101	eng	Detouillon, Da	2020/11/17			ecn no	-	rel level	Released
TOLERANCES UNLESS OTHERWISE SPECIFIED		chr	-	-						
surface	ISO 1302	appr	Wollin, Severi	2020/11/13	product family	-	rel level	Released	-	
linear	0.X ±0.3 0.XX ±0.10 0.XXX ±0.005	Amphenol FCI		DSUB METAL HOOD ANGLED		dwg no	8655DMx2B13KLF		rev	A
angular	0° ±2°	cat. no.	-	Product - Customer Drw		sheet 2 of 4				

Amphenol FCI

© 2016 AFCI

PART NUMBER	PACK	HOOD SIZE
8655DMBS2B13KLF	KIT	25

A

B

C

D

A

B

C

D

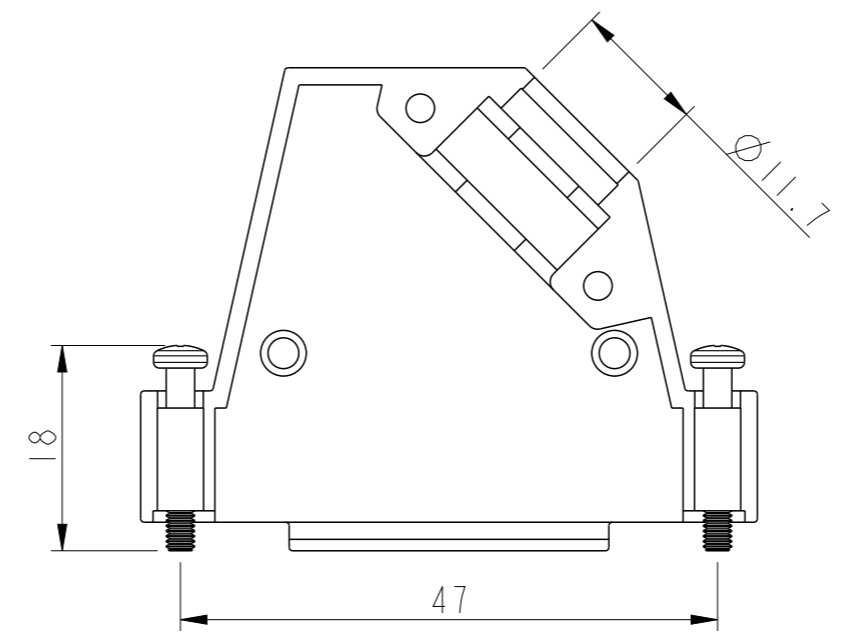
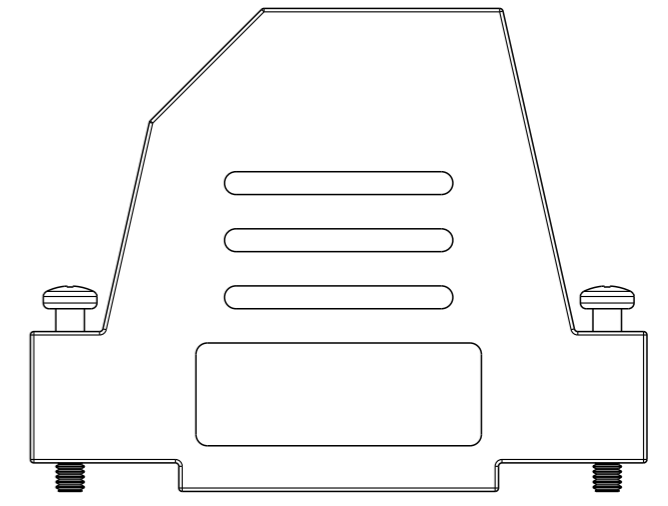
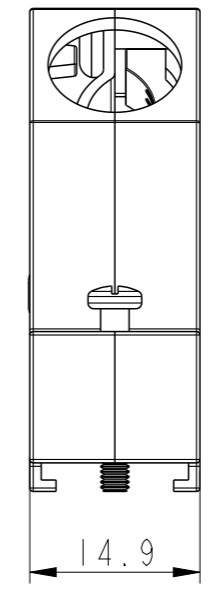
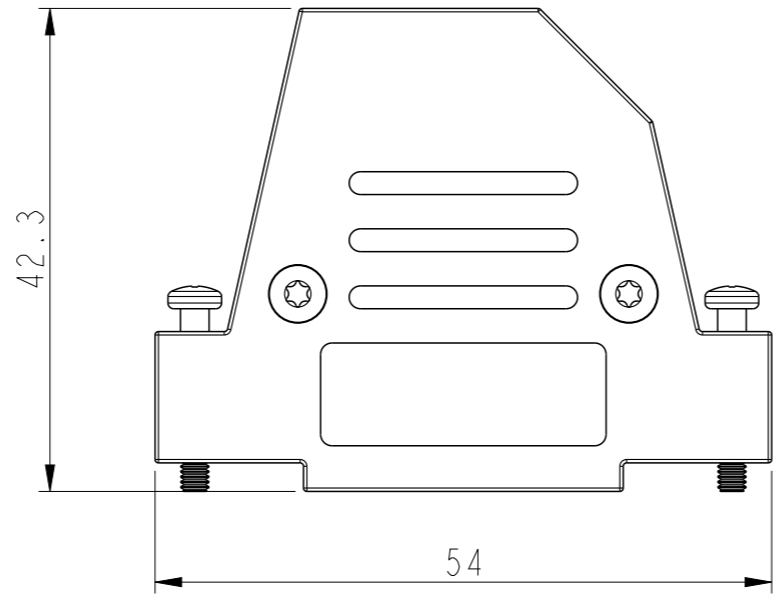
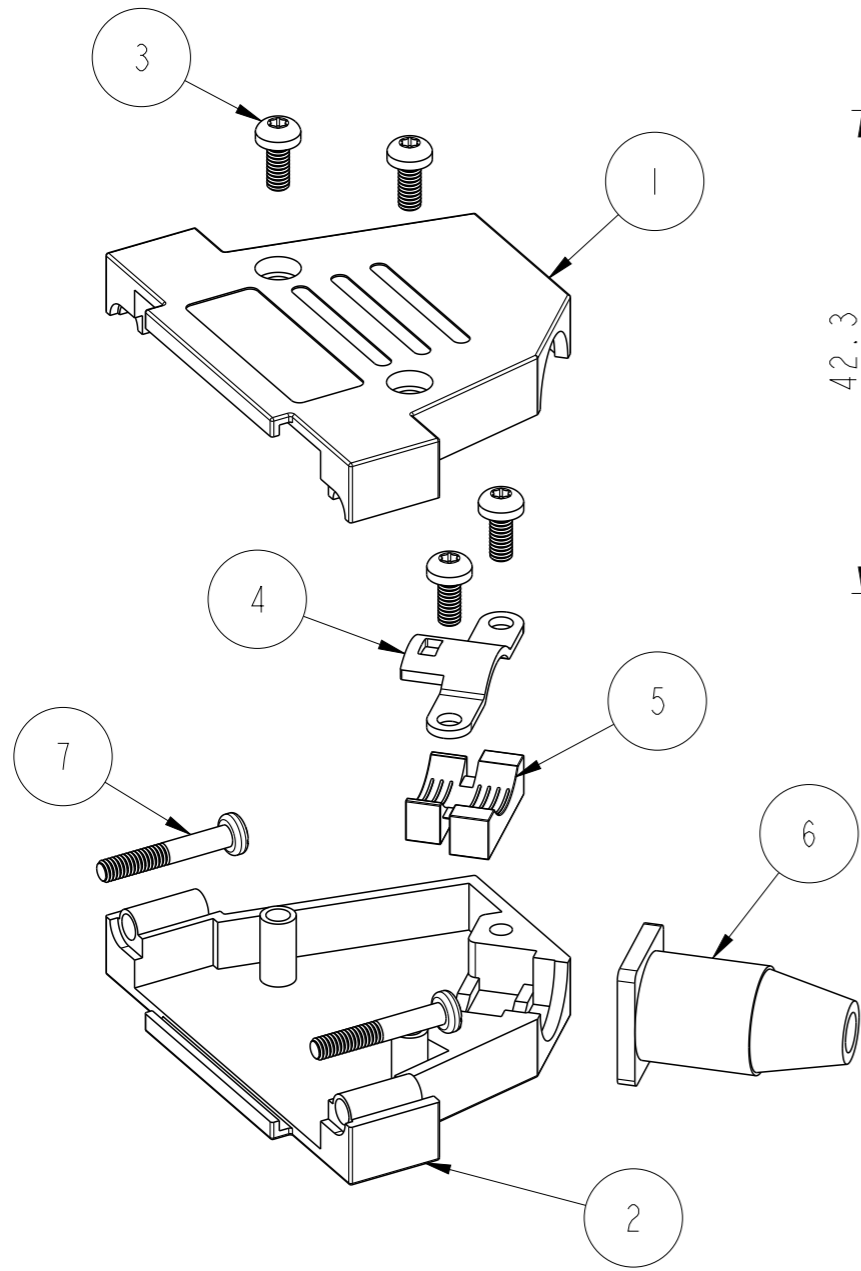

ITEM NO.	QTY.	PART DESCRIPTION
1	1	D45SL25-UPPER COVER
2	1	D45SL25-LOWER COVER
3	4	M2.5X6 SCREW
4	1	CABLE CLAMP
5	1	PLASTIC INSERT
6	1	RUBBER GROMMET
7	2	UNC4-40x18 JACKSCREW

spec ref	-	dr	Dipu Joseph	2020/09/14	projection	mm	size	A3	scale	1:1	
tolerance std	ISO 406 ISO 1101	eng	Detouillon, Da	2020/11/17			ecn no	-	rel level	Released	
TOLERANCES UNLESS OTHERWISE SPECIFIED		chr	-	-			product family	-	rel level	Released	
surface	linear	0.X	±0.3	<b>Amphenol FCI</b>	DSUB METAL HOOD ANGLED		dwg no	8655DMx2B13KLF		rev	A
		0.XX	±0.10		cat. no.	-	Product - Customer Drw	sheet 3 of 4			
	angular	0°	±2°								

PART NUMBER	PACK	HOOD SIZE
8655DMCS2B13KLF	KIT	37

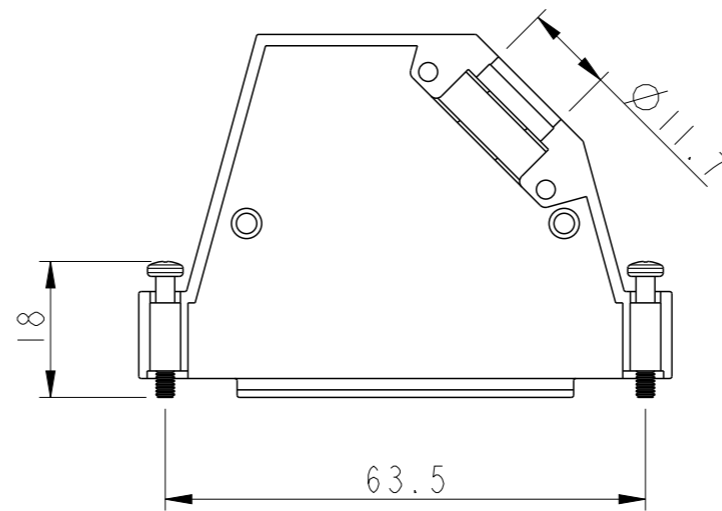
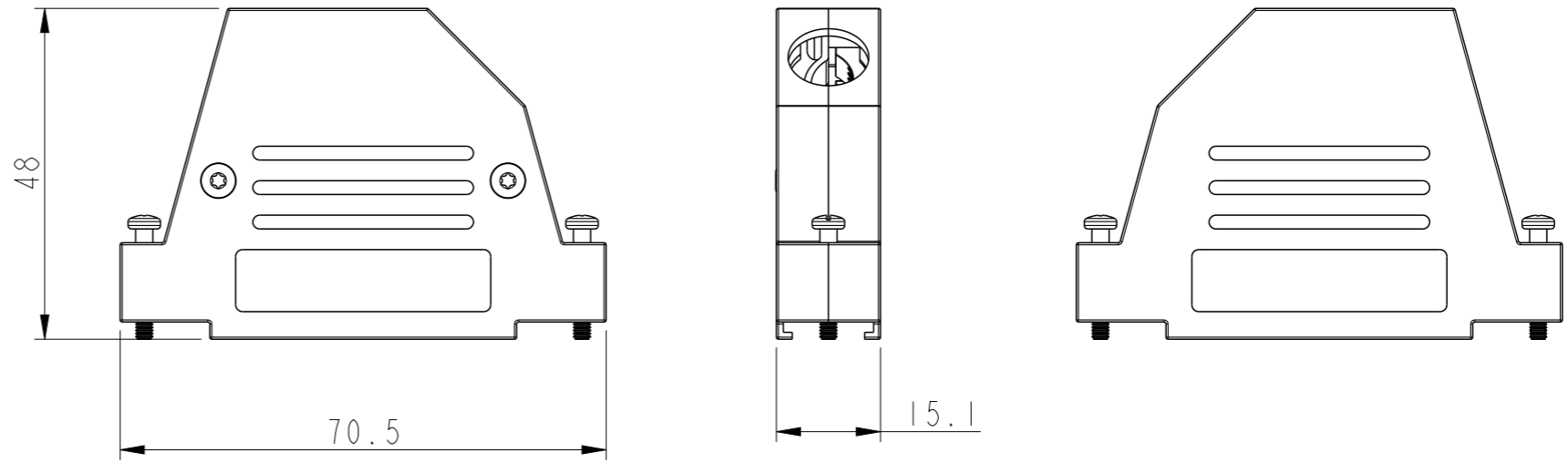
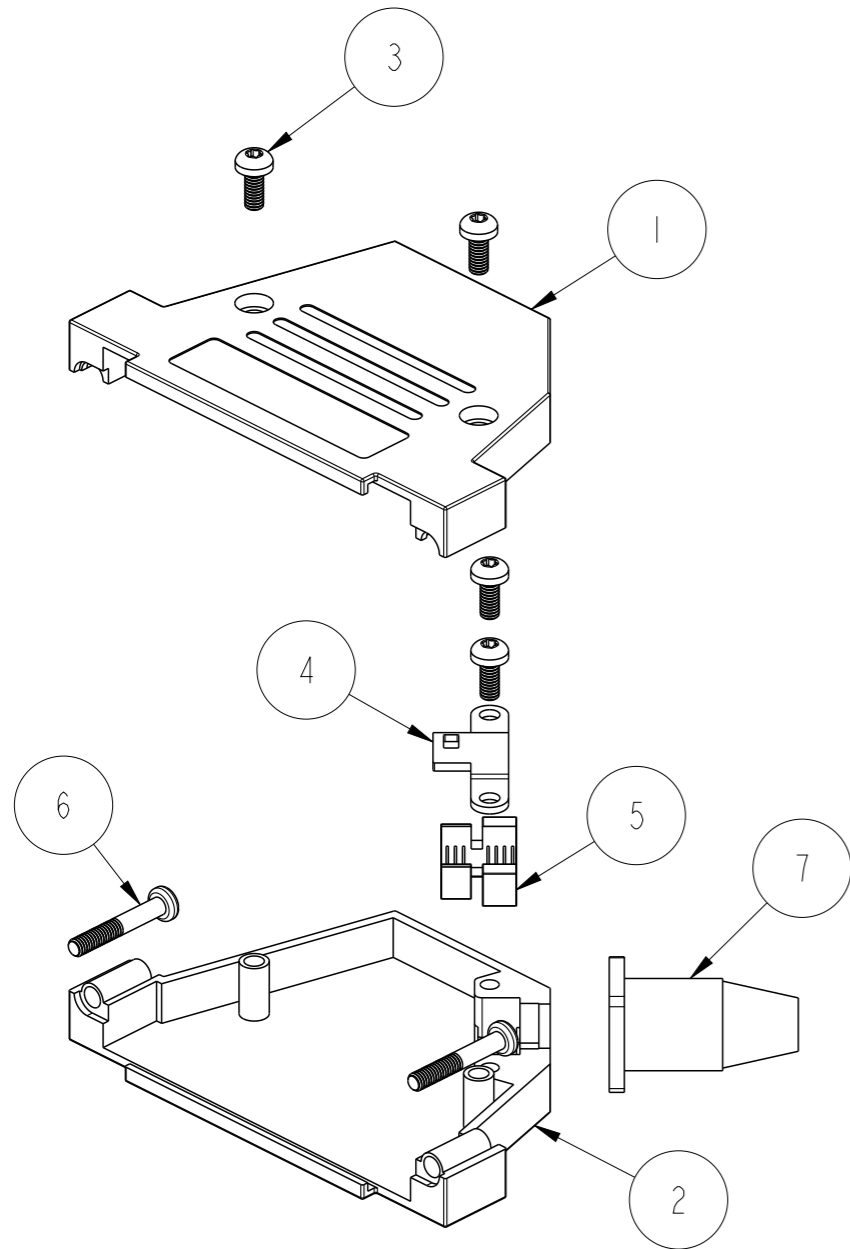

ITEM NO.	QTY.	PART DESCRIPTION
1	1	D45SL37-UPPER COVER
2	1	D45SL37-LOWER COVER
3	4	M2.5X6 SCREW
4	1	CABLE CLAMP
5	1	PLASTIC INSERT DTSL 15-37 TOP & SIDE METALISED
6	2	UNC4-40x18 JACKSCREW
7	1	RUBBER GROMMET

spec ref	-	dr	Dipu Joseph	2020/09/14	projection	mm	size	A3	scale	1:1
tolerance std	ISO 406 ISO 1101	eng	Detouillon, Da	2020/11/17			ecn no		-	
TOLERANCES UNLESS OTHERWISE SPECIFIED		chr	-	-			rel level		Released	
surface	linear	appr	Wollin, Severi	2020/11/13	product family	-	-		rev	A
ISO 1302	angular	Amphenol FCI		DSUB METAL HOOD ANGLED		cat. no.	-	Product - Customer Drw	sheet 4 of 4	