

REVISIONS

P	LTR	DESCRIPTION	DATE	DWN	APVD
A		INITIAL RELEASE	02APR2015	DL	CW
B		ECR-15-014706	10OCT2015	DL	CW
BI		ECR-15-016505	11NOV2015	DL	CW
C		ECR-17-007409	25MAY2017	DL	CW

NOTES:

- TECHNICAL CHARACTERISTICS:
 INSULATION MATERIAL: PC
 RATED VOLTAGE: 400 V
 RATED CURRENT: 10 A
 INSULATION RESISTANCE: $\geq 400M\Omega$
 RATED IMPULSE VOLTAGE: 6 KV
 POLLUTION DEGREE: 3
 FLAMMABILITY: UL94V-0
 MATING CYCLES: 500 CYLCES
 WIRE RANGE: 0.14-2.5 mm² (26-14 AWG)
 CONTACT TYPE: CRIMP CONTACT
- CONTACT NEED TO BE ORDERED SEPARATELY.
 (ORDER No. REFER TO DRAWING: T20200X20XX000)

注释:

- 技术参数:
 绝缘材料: PC
 额定电压: 400V
 额定电流: 10A
 绝缘电阻: $\geq 400M\Omega$
 额定脉冲电压: 6 KV
 污染等级: 3
 阻燃等级: UL94V-0
 插拔次数: 500次
 接线范围: 0.14-2.5 mm² (26-14 AWG)
 接线类型: 冷压接
- 端子需要单独订购.
 (订货号参考图面: T20200X20XX000)

M3 SCREW, RECOMMENDED
 TIGHTENING TORQUE 0.5Nm
 M3螺丝, 推荐扭力矩为0.5Nm

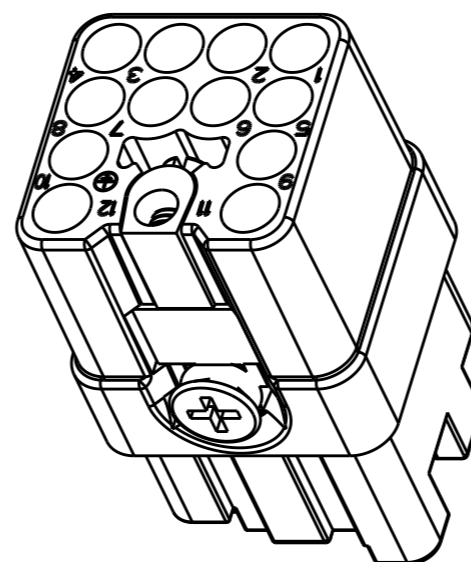
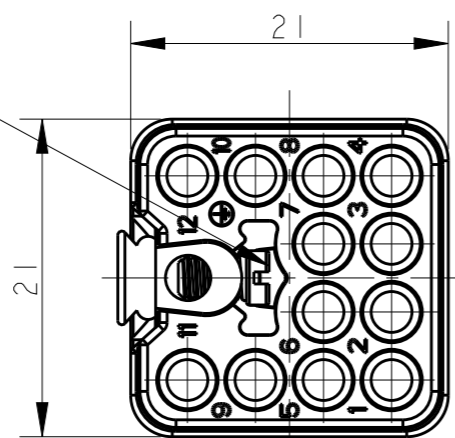

M3 SCREW, RECOMMENDED
 TIGHTENING TORQUE 0.5Nm
 M3螺丝, 推荐扭力矩为0.5Nm

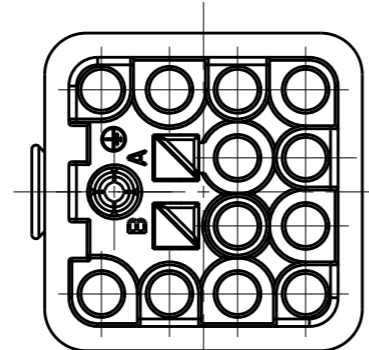
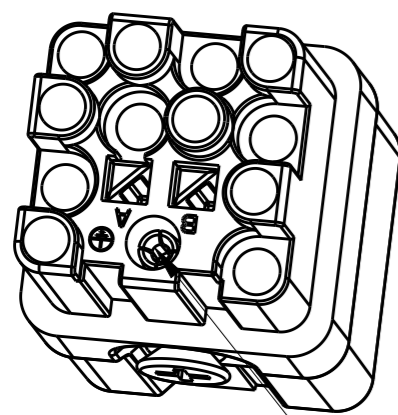
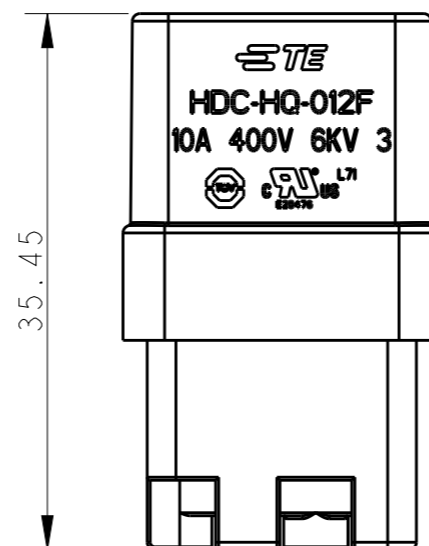
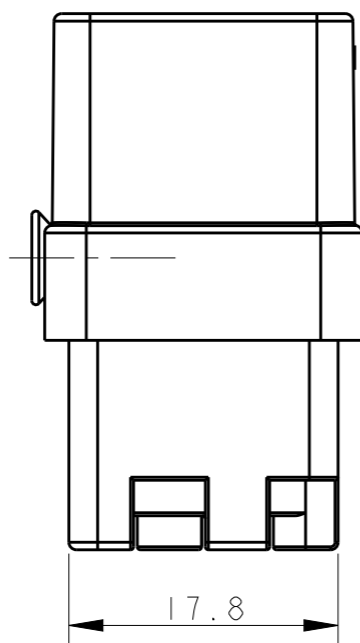
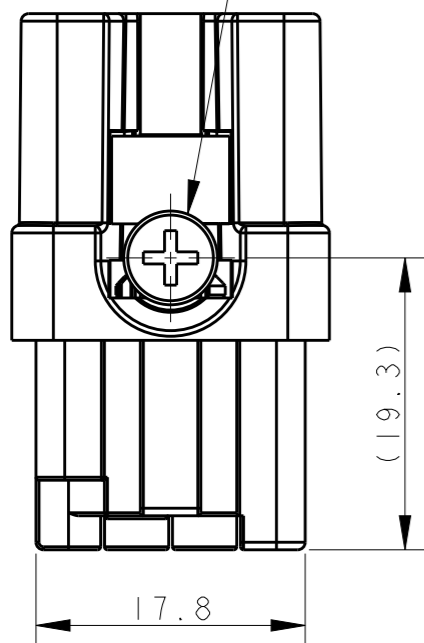

GROUNDING CONTACT TYPE: SCREW CONTACT
 GROUNDING CONTACT FINISH: SILVER PLATED
 WIRE RANGE: 2.5mm² (AWG14)
 接地针类型: 螺丝压接
 接地针表面处理: 镀银
 接线范围: 2.5mm² (AWG14)

T2080122201-000	HQ-012-F	HQ-012 FEMALE INSERT HQ-012 母插
PART NUMBER 料号	PART DESCRIPTION 描述	

THIS DRAWING IS A CONTROLLED DOCUMENT.	
DIMENSIONS: mm	TOLERANCES UNLESS OTHERWISE SPECIFIED: 0 PLC ±- 1 PLC ±- 2 PLC ±- 3 PLC ±- 4 PLC ±- ANGLES ±-
MATERIAL	FINISH

DWN	31MAR2015
DAVID LI	
CHK	31MAR2015
CHRIS WANG	
APVD	31MAR2015
XU XIANG	
PRODUCT SPEC	108-137114
APPLICATION SPEC	114-137114
WEIGHT	-
CUSTOMER DRAWING	

TE Connectivity		NAME		RESTRICTED TO
		HQ-012-F		
SIZE	CAGE CODE	DRAWING NO	-	
A3	-	©-T2080122201000	-	
SCALE		SHEET	OF	REV
2:1		1	1	C