

Panel cutout M1:1

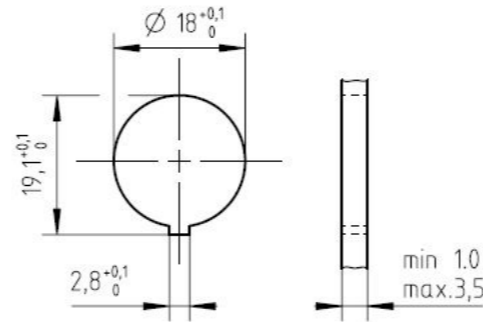

Number of contacts	Standard	3	4	5	5	6	7	7	8	12	14	14	19	
Contact arrangement	IEC 61076-2-106	03-a	04-a	05-a	05-b	06-a	07-a	07-b	08-a	12-a	14-a	14-b	19-a	
Contact arrangement	IEC 60130-9 <sup>n</sup>	yes	no	yes	no	yes	no	yes	no					
Rated voltage <sup>2)</sup>	IEC 60664-1	300 V (100 V)	300 V (63 V)	100 V (32 V)	300 V (63 V)	100 V (32 V)	150 V (32 V)	60 V (32 V)						
Rated voltage	UL 1977	250V						60V						
Rated impulse withstand voltage <sup>2)</sup>	IEC 60664-1	1500 V (1500 V)	1200 V (800 V)	1500 V (1500 V)	1200 V (800 V)									
Pollution degree <sup>2)</sup>	IEC 60664-1	1 (2)												
Installation category	IEC 60664-1	I												
Insulation group	IEC 60664-1	II, 400 ≤ CTI < 600												
Current rating	IEC 60512-5-2 UL 1977	10A/+40°C			7A/+40°C						3A/+40°C			
Insulation resistance	IEC 60512-3-1	>10 <sup>10</sup> Ohm <sup>3)</sup>												
Contact resistance	IEC 60512-2-1	<5mOhm												
Climatic category	IEC 60668-1	40 / 100 / 56												
Temperatur range	IEC 60668-1	-40°C...+100°C / -40°F...+212°F												
IP degree	IEC 60529	IP 40												
Insertion and withdrawal force	IEC 60512-13-2	25N	30N	35N	35N	50N	55N	55N	60N	50N	50N	50N	60N	
mechanical operation	IEC 60512-9-1	Silver ≥500 mating cycles / Gold ≥1000 mating cycles												
housing material		brass and / or zinc die cast, nickel plated or thermoplast												
dielectric material		thermoplastic												
contacts		silver or gold plated												
termination technique		solder												
wire gauge		≤0,5mm <sup>2</sup> / 20 AWG						≤0,35mm <sup>2</sup> / 22 AWG						
flamability		UL 94 VO												
locking system		metal screw coupling; tightening torque 0,7 - 1,5 Nm												

Gewicht (errechnet) / Calc WT: 0,012 kg  
 Prüfmaß / Testdimension  
 Teileindex / Partindexnumber:  
 Bagatelle change:

Zul. Abw./Tolerances:  
 DIN / ISO 13715

Maßstab / Scale: 2:1; 1:1  
 A3  
**CUSTOMER DRAWING**

Gez. Drawn	10.02.2020	MCARLE	
Status	Released		
Gepr. Checked	10.02.2021	MBERTSCH	
02	202000083	03.11.2020	MCARLE
01	202000001	10.02.2020	MCARLE
Index	Änderung / Description	Datum / Date	Name

**Amphenol Tuchel Industrial GmbH**

Male receptacle rear mounting  
 M CA T 3XXX 100+110+118 U  
 Ers. f. / Replacement for:

	19 (19-a)	Ag	T 3692 100 U
		Au	T 3692 118 U
	14 (14-b)	Ag	T 3672 100 U
		Au	T 3672 118 U
	14 (14-a)	Ag	T 3652 110 U
		Au	T 3652 100 U
	12 (12-a)	Ag	T 3637 110 U
		Au	T 3637 100 U
	8 (08-a)	Ag	T 3506 100 U
		Au	T 3506 118 U
	7 (07-b)	Ag	T 3486 100 U
		Au	T 3486 118 U
	7 (07-a)	Ag	T 3477 100 U
		Au	T 3477 118 U
	6 (6-a)	Ag	T 3402 100 U
		Au	T 3402 118 U
	5 (05-b)	Ag	T 3358 100 U
		Au	T 3358 118 U
	5 (05-a)	Ag	T 3362 100 U
		Au	T 3362 118 U
	4 (04-a)	Ag	T 3302 100 U
		Au	T 3302 118 U
	3 (03-a)	Ag	T 3262 100 U
		Au	T 3262 118 U
	2 (Pin 1+3)	Ag	T 3202 100 U
		Au	T 3202 118 U

Contact arrangement View on mating side  
 Number of contacts (Contact arrangement acc. DIN EN 61076-2-106)  
 Part number

<sup>1)</sup> Edition 2000-05  
<sup>2)</sup> values in brackets are according to DIN EN 61076-2-106  
<sup>3)</sup> under operating conditions >10<sup>9</sup> Ohm  
 Do not connect or disconnect under load Metal housing parts shall be securely incorporated to protected ground  
 Remark for gold plated contacts:  
 In order to avoid brittle inter-metallic connections, gold plated terminals have to be tin-plated in the solder area.  
 All technical data have been measured in a laboratory environment and can be different during practical usage of the product. Any product information is for descriptive usage only and not legally binding, particularly the information does not constitute or provide any legal guaranties ("Beschaffenheitsgarantie" or "Haltbarkeitsgarantie").

Coping of this document and giving it to others and the use or communication of the contents thereof, are forbidden without express authority. Offenders are liable to the payment of damages. All rights are reserved in the event of the grant of a patent or the registration of the utility model or design.  
 Weitergabe sowie Vervielfältigung dieser Unterlage, Verwertung und Mitteilung ihres Inhalts nicht gestattet, soweit nicht ausdrücklich zugestanden. Zuwiderhandlungen verpflichten zu Schadensersatz. Alle Rechte für den Fall der Patenterteilung oder Gebrauchsmuster-Eintragung vorbehalten.