

ISS.	AMEND	DATE
1	1st DRAWN	14/12/15
2	ADD M3 VARIANT	16/07/18
3	ADD MIN MAX TEMP	30/06/20

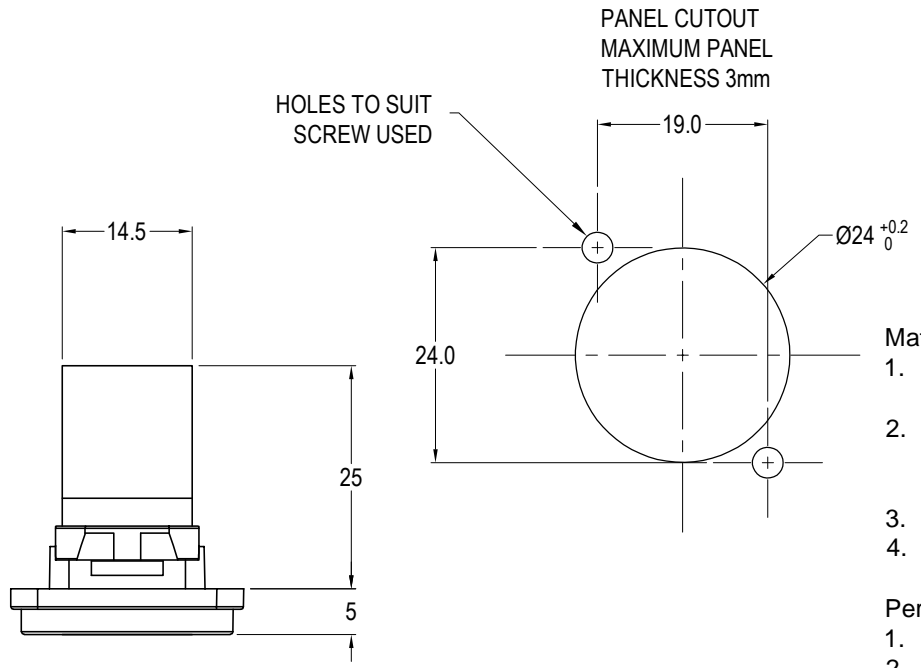

- Material:**
- RJ45 In-Line Coupler: PC/ABS, UL 94V-0, Black colour
  - RJ45 In-Line Coupler Contact: Phosphor Bronze, 3-50 micro inches gold plating over nickel plate.
  - PCB: FR4, UL 94V-0
  - Frame: Black Nickel plated zinc diecast

VARIANTS	
PART No.	HOLE DETAILS
CP30222MB	HOLE Ø3.50 x CSK 82° x Ø5.85
CP30222M3B	M3 HOLES

- Performance:**
- T568A & T568B wiring.
  - Meet ISO/IEC 11801 and EN50173
  - Meet ANSI/TIA/EIA 568B.2
  - Operating Temperatures: Min -10°C Max +60°C

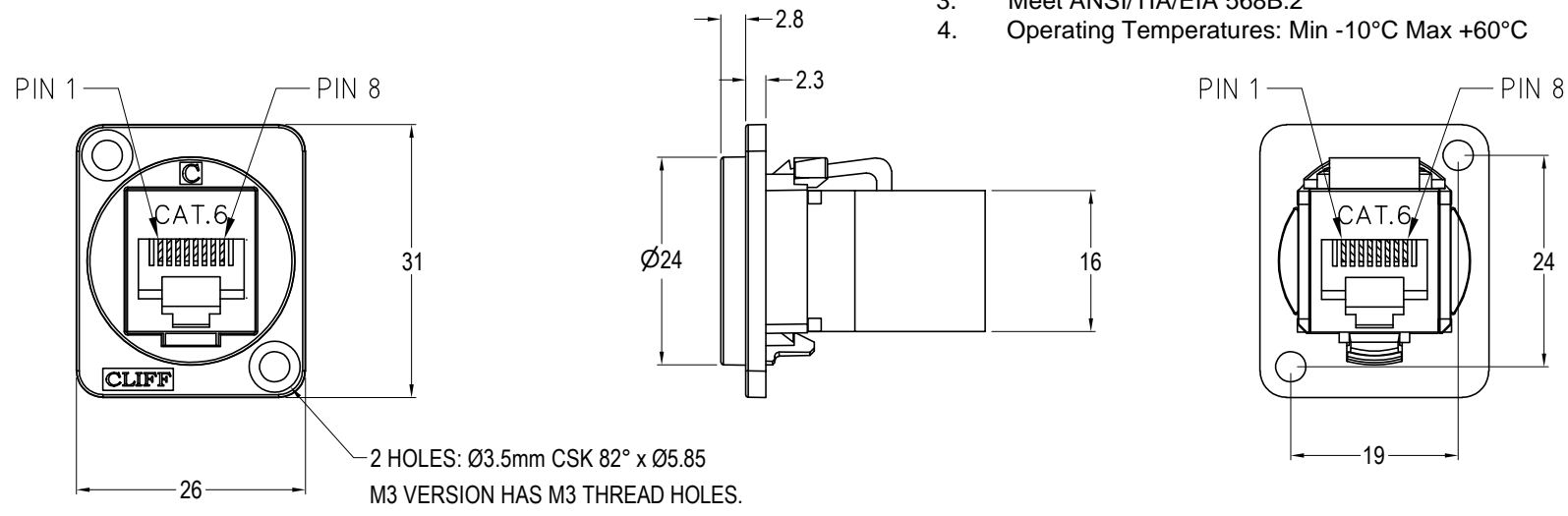

<b>RoHS</b> COMPLIANT
TOLERANCE NO DEC. PLACE ± 1 DEC. PLACE ± 2 DEC. PLACE ± HOLE Ø ± ANGLES ± UNLESS OTHERWISE STATED
DO NOT SCALE