

Nov.1.2021 Copyright 2021 HIROSE ELECTRIC CO., LTD. All Rights Reserved.  
In case of consideration for using Automotive equipment / device which demand high reliability, kindly contact our sales window correspondents.

COUNT	DESCRIPTION OF REVISIONS	BY	CHKD	DATE	COUNT	DESCRIPTION OF REVISIONS	BY	CHKD	DATE
△					△				
△					△				
△					△				

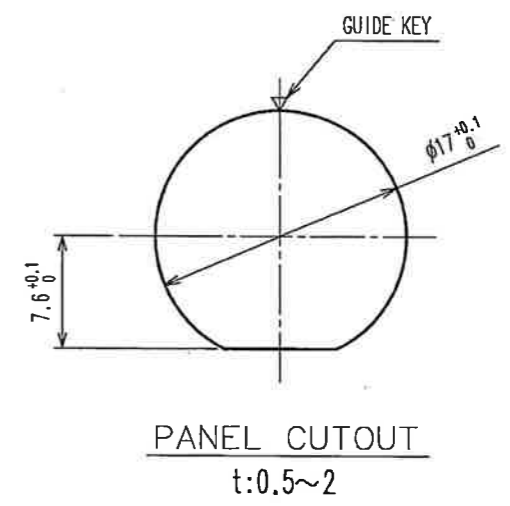
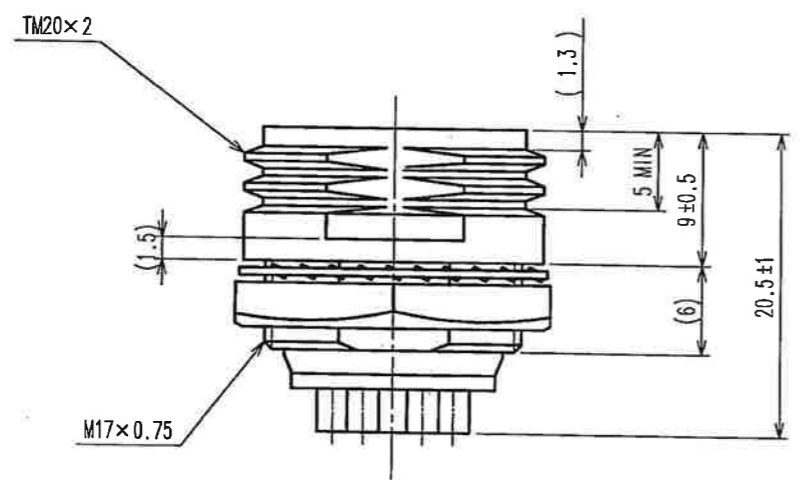
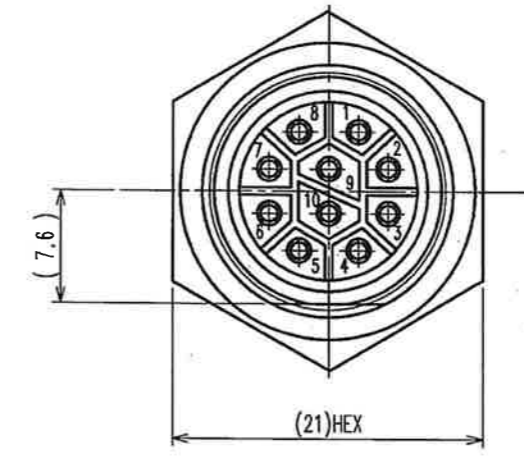
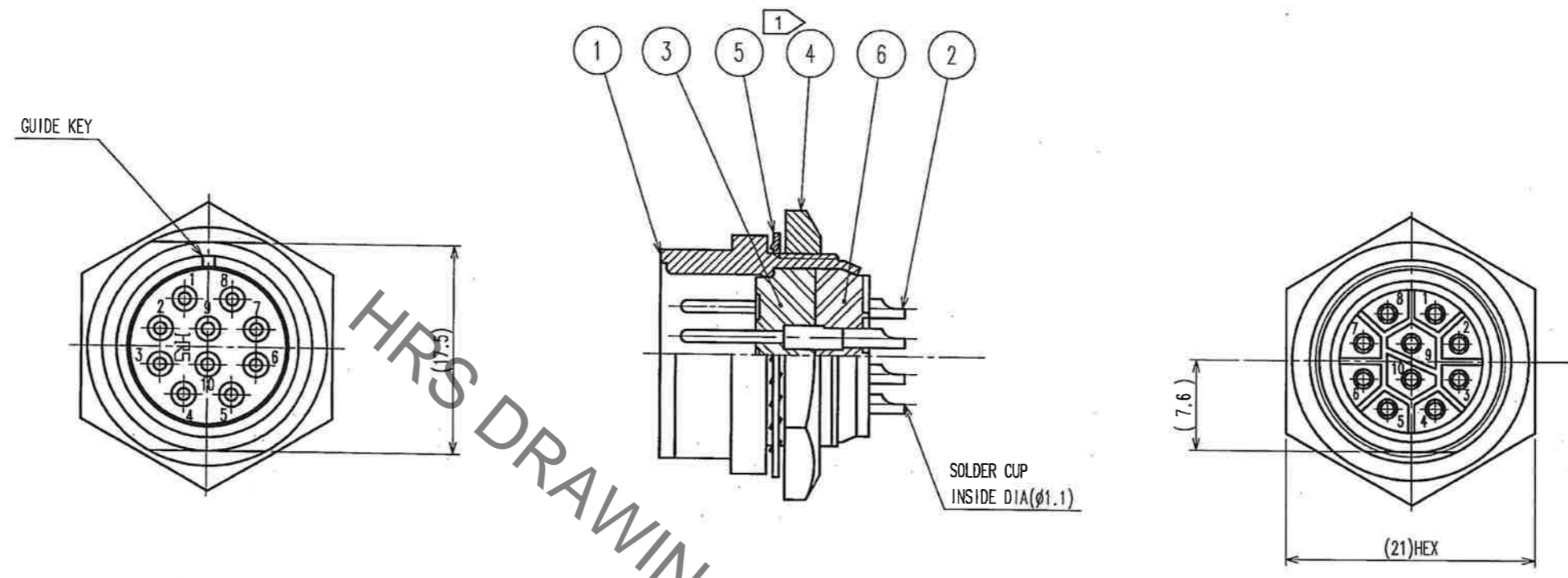

HRS DRAWING FOR REFERENCE

NOTE: ① THE RECOMMENDED CLAMP TORQUE OF REF.NO.④: 3~4N·m  
LOCTITE 242, LOCTITE OR EQUIVALENT IS RECOMMENDED TO  
PREVENT REF.NO.④ FROM LOOSENING.

3	DIALLYL PHTHALATE (BLACK) UL94V-0	6	DIALLYL PHTHALATE (BLACK) UL94V-0		
2	BRASS SILVER PLATING (PLATING THICKNESS: 4μm min)	5	PHOSPHOR BRONZE NICKEL PLATING		
1	ZINC ALLOY MATTE FINISH CHROME PLATED	4	BRASS NICKEL PLATING		
NO.	MATERIAL	FINISH, REMARKS	NO.	MATERIAL	FINISH, REMARKS

CODE NO. (OLD)	DRAWN	DESIGNED	CHECKED	APPROVED	RELEASED
	T. Suzuki	T. Suzuki	N. Kobayashi	T. Komatsu	
	'21.06.03	'21.06.03	'21.06.07	'21.06.09	

SCALE 2 : 1	DRAWING NO. EDC3-007609-76-00	PART NO. RM15TRD-10P(76)
UNITS mm	HRS HIROSE ELECTRIC CO., LTD.	CODE NO. CL109-0687-1-76

TO  
R