

THIS DRAWING IS UNPUBLISHED.

RELEASED FOR PUBLICATION

20

© COPYRIGHT 2020 TE Connectivity. All Rights Reserved. ALL RIGHTS RESERVED.

LOC	DIST	REVISIONS					
		P	LTR	DESCRIPTION	DATE	DWN	APVD
-	-		A	RELEASE TO PRODUCTION	22JUN2022	SS	PP

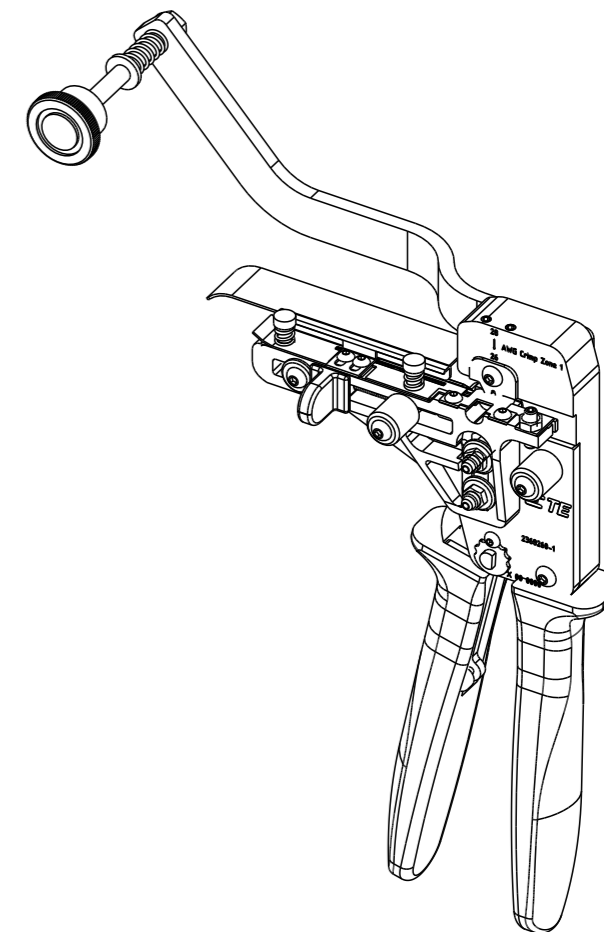
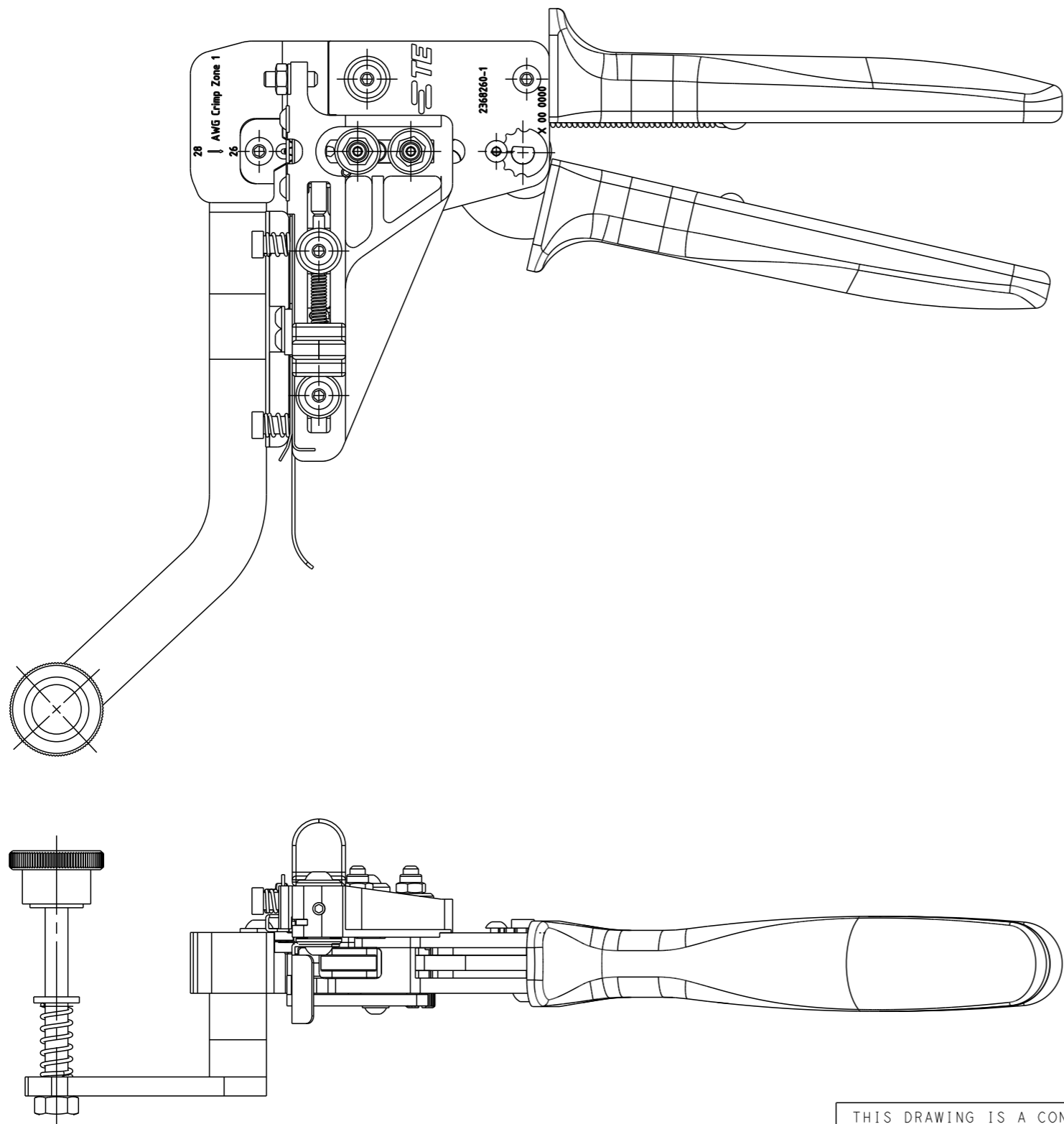

NOTES:

1. STRAIGHT ACTION PRINCIPLE;
2. RATCHED RELEASE;
3. SIMPLE PRESSURE ADJUSTMENT WITH LOCKING DEVICE;
4. FEEDING AND CUTTING DEVICE
5. PRECISELY GROUND PROFILES;
6. ERGONOMIC SOFT GRIPS, COLOUR TRAFFIC BLUE (RAL 5017);
7. FULLY RECYCLABLE;
8. APPLICATION RANGE: T1 INDUSTRIAL CONTACTS;
9. CROSS SECTION RANGE: AWG 28-26
10. REEL WITH CONTACTS (500 PCS) IS INCLUDED, (NOT SHOWN IN PICTURES)

PARTNUMBER:  
2368260-1

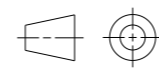
THIS DRAWING IS A CONTROLLED DOCUMENT.		DWN S. SHARMA 15JUN2022	 TE Connectivity	
DIMENSIONS: mm		CHK P. POORTER 21JUN2022		
		APVD J. DE BRUIJN 22JUN2022	NAME SPE T1 MANUAL CRIMP TOOL AWG28-26	
TOLERANCES UNLESS OTHERWISE SPECIFIED:		PRODUCT SPEC -	APPLICATION SPEC -	
MATERIAL -		FINISH -	WEIGHT -	RESTRICTED TO -
0 PLC ± 1 PLC ±0.1 2 PLC ±0.01 3 PLC ±0.001 4 PLC ±0.0001 ANGLES ±		SIZE A3	CAGE CODE 00779	DRAWING NO C-2368260
CUSTOMER DRAWING		SCALE NTS	SHEET 1	OF 1
			REV A	