

REVISIONS					
REV	ECO	DESCRIPTION	DATE	BY	APPR
A1	-	RELEASE NEW DRAWING	Oct/08/22	LUCAS	TOMMY

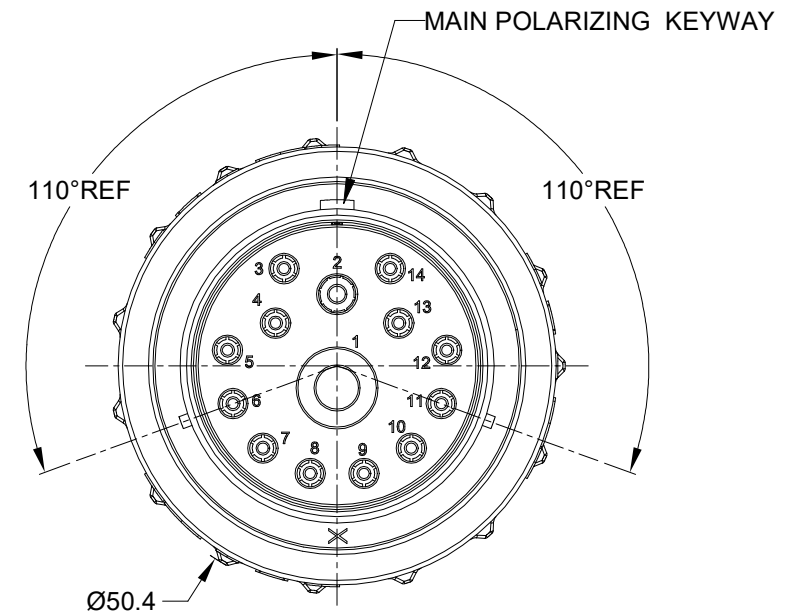
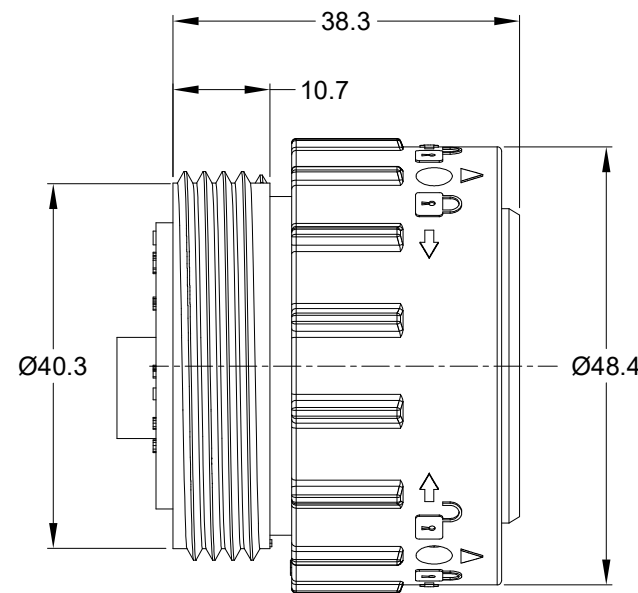
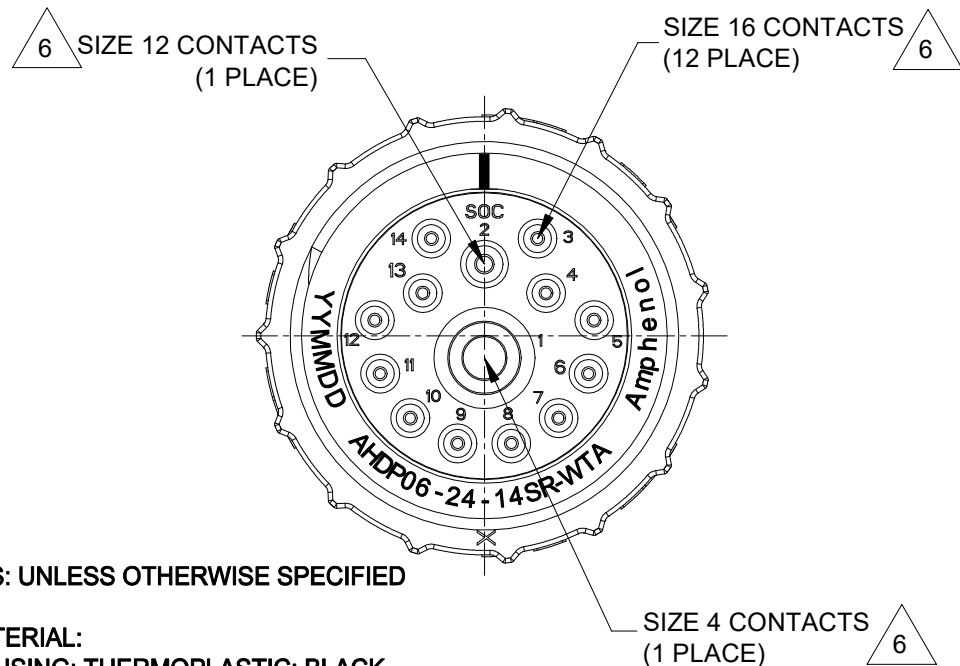

NOTES: UNLESS OTHERWISE SPECIFIED

- MATERIAL:**  
HOUSING: THERMOPLASTIC; BLACK  
SEAL: SILICONE RUBBER
- MODIFICATIONS:** WIDE THREADED ADAPTER(WTA)  
REDUCED DIA. WIRE SEAL.
- SPECIFICATIONS:**
  - OPERATING TEMPERATURE: -55°C TO +125°C.
  - DIELECTRIC WITHSTANDING VOLTAGE: LESS THAN 2 MILLIAMPS CURRENT LEAKAGE @ 1500 VOLTS AC.
  - INSULATION RESISTANCE: 1000 MEGOHM MIN @ 25°C.
  - MOISTURE RESISTANCE: IP67&IP69K ( MATED CONDITION ).
  - MATING CYCLE DURABILITY: 100 CYCLES
  - RoHS COMPLIANT
- MATING PART:** AHDP04-24-14P\* (\* = SEAL TYPE)
- ALL DIMENSIONS ARE FOR REFERENCE USE ONLY.**

6 CONTACT SIZE AND WIRE RANGE:

CONTACT SIZE	MIN. INSUL O.D.	MAX. INSUL O.D.	TYPICAL WIRE RANGE	CURRENT RATING
4	6.63 mm (.261 in)	7.41 mm (.292 in)	6 AWG (16.0-13.0mm <sup>2</sup> )	100 AMPS
12	2.46 mm (.135 in)	4.01 mm (.158 in)	10-14 AWG (6.0-2.0mm <sup>2</sup> )	25 AMPS
16	1.35 mm (.053 in)	3.05 mm (.120 in)	14-20 AWG (2.0-0.5mm <sup>2</sup> )	13 AMPS

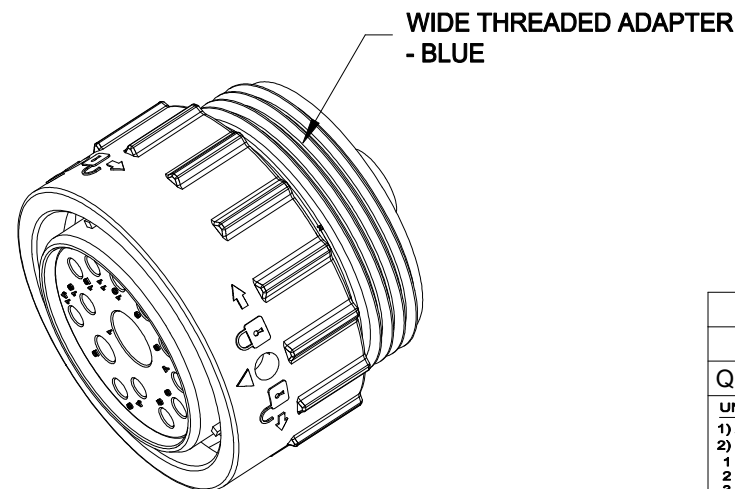

TITLE: PLUG,24-14 POS,SOK CONT.,REDUCED DIA. SEAL,AHDP  
DWG NO.: AHDP06-24-14SR-WTA  
REV: A1  
SH: 1  
OF: 1

AHD06-24-14SR-WTA		REF:HDP26-24-14SE-L024	
PART NUMBER		DESCRIPTION	
QUANTITY	MATERIALS LIST		
UNLESS OTHERWISE SPECIFIED		SIGNATURES	
1) All dimensions are in metric(mm).		DRAWN: LUCAS,CHAI	
2) Tolerances are as follows:		DATE: Oct/08/22	
1 PL DEC ±0.30		CHECKED: ORION,LI	
2 PL DEC ±0.15		DATE: Oct/10/22	
3 PL DEC ±0.08		ENGINEER:	
3) Note reference =		APPROVAL: TOMMY,XIE	
MATERIAL SPECIFICATIONS:		DATE: Oct/14/22	
PROCESS SPECIFICATIONS:		CUSTOMER:	
NEXT ASSY:		THIS DRAWING IS SUPPLIED FOR INFORMATION ONLY. DESIGN FEATURES, SPECIFICATIONS AND PERFORMANCE DATA SHOWN HEREON ARE THE PROPERTY OF THE AMPHENOL CORPORATION. NO RIGHTS OF REPRODUCTION ARE IMPLIED. ALL DIMENSIONS ARE SUBJECT TO NORMAL MANUFACTURING VARIATIONS.	
SIZE: B		TYPE: C-	
DWG NO.: AHDP06-24-14SR-WTA		REVISION: A1	
SCALE: NONE		SHEET 1 OF 1	