

REV	ECN	APP'D
-	9448	MD 10/21/2021

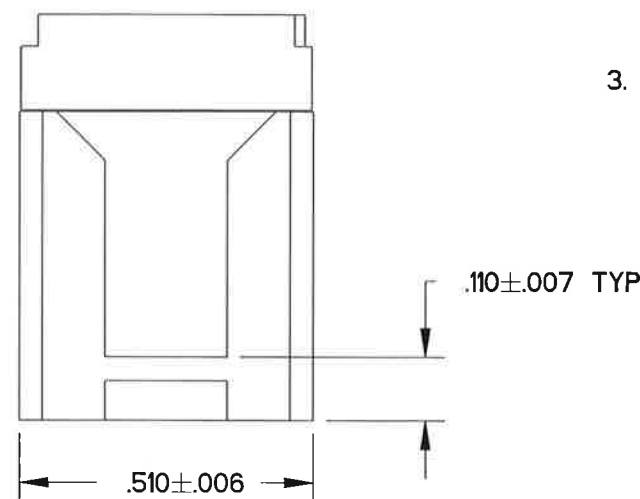
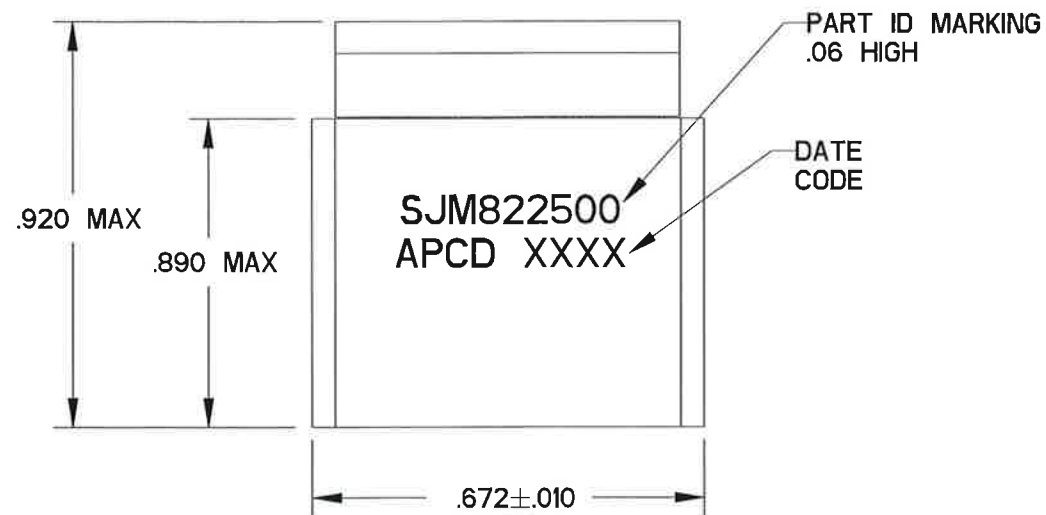
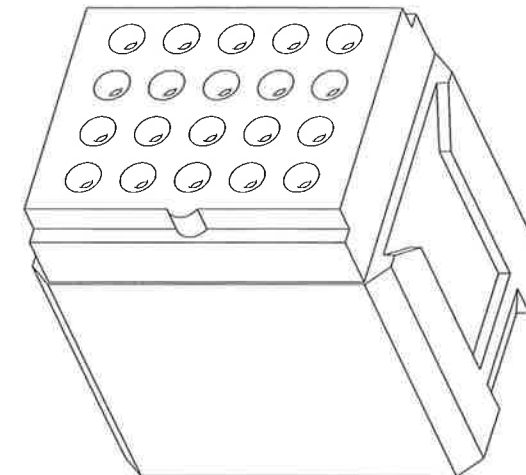
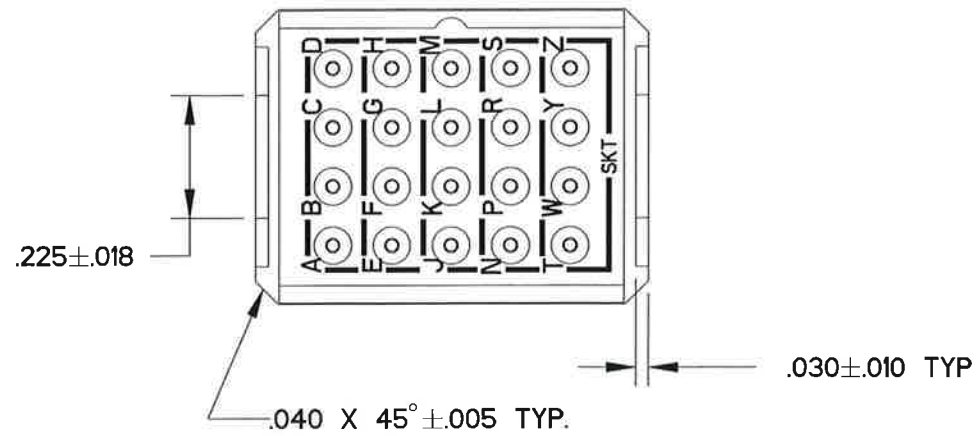

NOTES:

- PART MEETS ALL REQUIREMENTS OF AS81714/60
- MATERIALS:
 GROMMET - SILICONE RUBBER PER A-A-59588
 BODY - POLYETHERIMIDE PER ASTM-D-5205
 INTERNAL CONTACT - BRASS PER ASTM-B16, GOLD PLATED PER MIL-DTL-45204
 CONTACT RETAINER CLIPS - STAINLESS STEEL PER ASTM-A666
- PART ACCEPTS M39029/22-191 SOCKET CONTACTS. SEE TABLE

MASTER COPY

APCD P/N	SUPPLIED	
	SKTS	PLUGS
SJM822500	21	2
SJM822501	-	-

DIMENSIONS ANSI Y14.5M UNITS: INCHES Pro/E FILE	TOLERANCES .XX ±0.01 .XXX ±0.005 ANGLES ±2.0°	PROJECTION 	Amphenol Pcd CUSTOMER DRAWING			TITLE SOCKET JUNCTION MODULE SIZE 22, 5-BUS		
			ENGR W. LAWSON Jul-12-21	CHKD <i>W. Lawson</i> 8/9/21	APP'D <i>M. D. [Signature]</i> 10 Aug 2021	SIZE B	CUSTOMER DWG NO. SJM822500	REV -
ORIGINAL	THIS DOCUMENT CONTAINS PROPRIETARY INFORMATION WHICH IS THE CONFIDENTIAL PROPERTY OF AMPHENOL PCD INC., BEVERLY, MA							

SJM822500

SJM822500