

WATERPROOF METAL HORN LOUDSPEAKERS

➤ MHS20T/ENC

EN54-24



TECHNICAL SPECIFICATIONS

EN54-24:2008

Certificate No: 0359-CPD-0166 TYPE B

ELECTRICAL

Rated power, Watts	20
Tappings 100 volt line, Watts	20/10/5/2.5/1.25
Transformer Impedance, Ohms 100V	500/1k/2k/4k/8k
Tappings 70.7 volt line, Watts	10/5/2.5/1.25/0.625
Driver impedance, Ohms	8
Effective Frequency Range, Hz (BSEN60268-5)	300-16,500
S.P.L. @ 4m, 1watt, dB, 1/3 Octave, 1KHz	81
S.P.L. @ 1m, 1watt, dB, Test Signal Bandwidth 100Hz-10kHz	101
S.P.L. @ 4m, Full power, dB, 1/3 Octave 1KHz	92
S.P.L. @ 1m, Full power, Test Signal Bandwidth 100Hz-10kHz	114
Dispersion at 1k/2k Hz, Degrees	143/66

ENVIRONMENTAL

IP-Rating	66
Max/Min Amb Temp	70°/-25°C
Relative Humidity	≤95%

MECHANICAL

Dimensions, Diameter x depth mm Ø	217 x 297
Net Weight, Kgs	2.7
Colour (Unless Specified)	RAL7035
Material	Die cast aluminium housing
Mounting Lockable Stainless Steel U bracket	

- MHS20T/ENC is supplied with capacitor for DC line monitoring
- MHS20T/ENC is BS5839 Part 8 Compliant
- Suitable for external use

MHS20T/ENC

WEATHERPROOF METAL HORN LOUDSPEAKERS

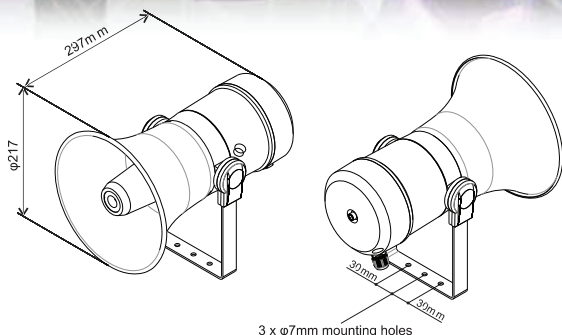

CIRCUIT DIAGRAM

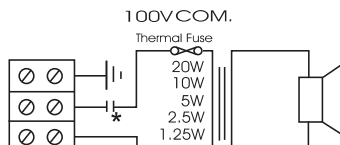

MHS20T/ENC
*with capacitor

WITH TRANSFORMER: 100V/70V LINE

	WHITE WIRE PLUS TAPPING					BLACK
100V	1.25W	2.5W	5W	10W	20W	COM
70V	0.625W	1.25W	2.5W	5W	10W	COM
IMP(Ω)	8K	4K	2k	1K	500K	

DISPERSION ANGLES

		HORIZONTAL	VERTICAL
1 OCT. PINK NOISE	500 Hz	360°	360°
1 OCT. PINK NOISE	1K Hz	143°	143°
1 OCT. PINK NOISE	2K Hz	66°	66°
1 OCT. PINK NOISE	4K Hz	40°	41°

FREQUENCY RESPONSE

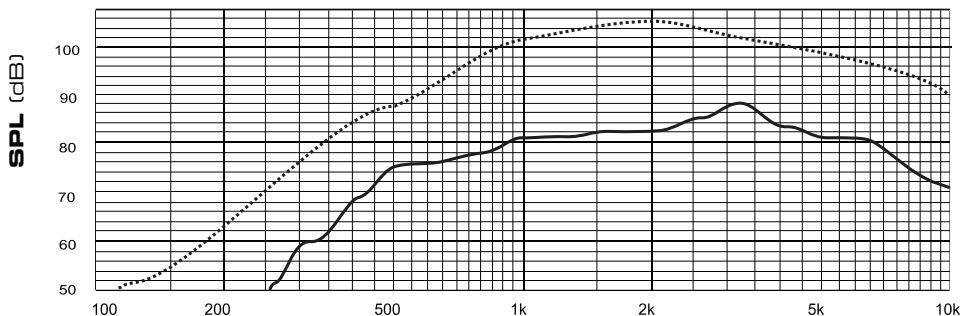

Frequency (Hz)

..... Sensitivity 100Hz-10000Hz Oct. Pink noise 1W/1 Meter)
 ——— Sensitivity 100Hz-10000Hz 1/3 Oct. Pink noise 1W/4 Meters)

*Active Equalizer Applied: To use or not, both can pass by EN54-24 limit
 (EQ Setting: +3.5dB@630Hz, +3.5dB@800Hz, -3.5dB@1250Hz, -3.5dB@1600Hz, -2.5dB@4KHz)

MHS20T/ENC has been tested in 100 hours max power (15W). The model does not deviate by more than +/- 3dB from the original test value. The frequency response curve and impedance complies with the original one. All SPL tests are performed in an anechoic chamber ($70m^3$)



Penton UK Ltd

Unit 2 Teville Industrials | Dominion Way | Worthing | West Sussex | BN14 8NW

T: +44 (0)1903 215315 | F: +44(0)1903 215415 | E: SALES@PENTONUK.CO.UK

www.pentonuk.co.uk

