NI-9206 Getting Started

2022-07-06



Contents

Overview.....	3
Safety Guidelines.....	3
Safety Voltages.....	4
Safety Guidelines for Hazardous Voltages.....	5
Safety Guidelines for Hazardous Locations.....	6
Special Conditions for Hazardous Locations Use in Europe and Internationally.	7
Electromagnetic Compatibility Guidelines.....	7
Special Conditions for Marine Applications.....	8
Preparing the Environment.....	8
NI 9206 Pinout.....	9
Signals.....	9
Connecting Floating Differential Signals.....	10
Connecting Grounded Differential Signals.....	11
Connecting RSE Voltage Signals.....	11
Connecting NRSE Voltage Signals.....	12
Connecting Fuel Cell Devices.....	12
NI 9206 Connection Guidelines.....	12
Connecting to a Spring-Terminal Connector.....	13
High-Vibration Application Connections.....	14
Where to Go Next.....	14
Worldwide Support and Services.....	14

Overview

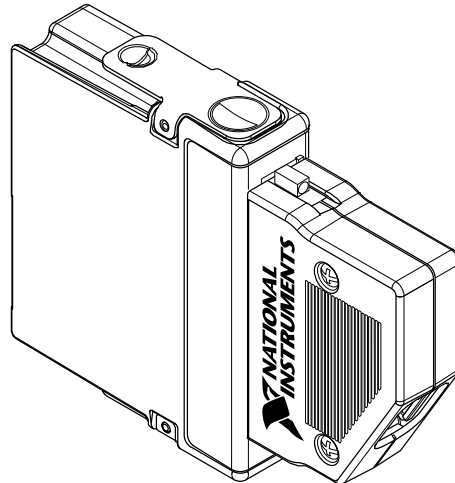

This document explains how to connect to the NI 9206.



Note Before you begin, complete the software and hardware installation procedures in your chassis documentation.



Note The guidelines in this document are specific to the NI 9206. The other components in the system might not meet the same safety ratings. Refer to the documentation for each component in the system to determine the safety and EMC ratings for the entire system.

Safety Guidelines

Operate the NI 9206 only as described in this document.



Caution This icon denotes a caution, which advises you to consult documentation where this symbol is marked.



Caution Do not operate the NI 9206 in a manner not specified in this document. Product misuse can result in a hazard. You can compromise the safety protection built into the product if the product is damaged in any way. If the product is damaged, return it to NI for repair.

Hazardous Voltage This icon denotes a warning advising you to take precautions to avoid electrical shock with the NI 9206.

Safety Voltages

Connect only voltages that are within the following limits:

Maximum voltage^[1]

AI, PFI0, and D0 to COM

±30 V DC

¹ The maximum voltage that can be applied or output between AI and COM without creating a safety hazard.

Isolation Voltages

Channel-to-channel	None
Channel-to-earth ground	
Continuous	
U.S. (UL 61010-1)	600 V DC, Measurement Category I
Europe (IEC 61010-1)	400 V DC, Measurement Category I
Withstand	2,500 V PK, verified by a 5 s dielectric withstand test

Measurement Category I is for measurements performed on circuits not directly connected to the electrical distribution system referred to as **MAINS** voltage. MAINS is a hazardous live electrical supply system that powers equipment. This category is for measurements of voltages from specially protected secondary circuits. Such voltage measurements include signal levels, special equipment, limited-energy

parts of equipment, circuits powered by regulated low-voltage sources, and electronics.



Caution Do not connect the NI 9206 to signals or use for measurements within Measurement Categories II, III, or IV.



Note Measurement Categories CAT I and CAT O are equivalent. These test and measurement circuits are for other circuits not intended for direct connection to the MAINS building installations of Measurement Categories CAT II, CAT III, or CAT IV.

Safety Guidelines for Hazardous Voltages

If hazardous voltages are connected to the device, take the following precautions. A hazardous voltage is a voltage greater than 42.4 Vpk voltage or 60 VDC to earth ground.



Caution Ensure that hazardous voltage wiring is performed only by qualified personnel adhering to local electrical standards.



Caution Do not mix hazardous voltage circuits and human-accessible circuits on the same module.



Caution Ensure that devices and circuits connected to the module are properly insulated from human contact.



Caution When module terminals are hazardous voltage LIVE (>42.4 Vpk/60 VDC), you must ensure that devices and circuits connected to the module are properly insulated from human contact. You must use the NI 9941 backshell kit to ensure that the terminals are not accessible.



Caution In addition to attaching the connector backshell to the NI 9206, you must install the entire system in a UL Listed, suitably rated NEMA or IP enclosure for safe use.

Figure 1. NI 9206 in a Suitably UL Rated NEMA or IP Enclosure

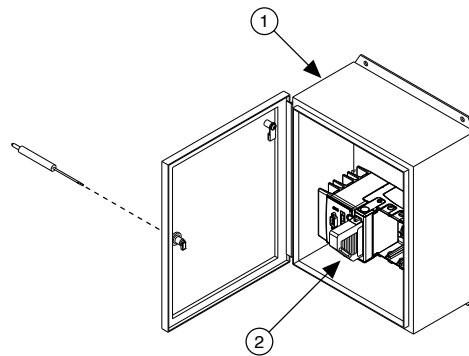

1. Suitably rated NEMA or IP enclosure that requires tool access
2. NI 9206 with NI 9941 connector backshell installed

Safety Guidelines for Hazardous Locations

The NI 9206 is suitable for use in Class I, Division 2, Groups A, B, C, D, T4 hazardous locations; Class I, Zone 2, AEx nA IIC T4 Gc and Ex nA IIC T4 Gc hazardous locations; and nonhazardous locations only. Follow these guidelines if you are installing the NI 9206 in a potentially explosive environment. Not following these guidelines may result in serious injury or death.



Caution Do not disconnect I/O-side wires or connectors unless power has been switched off or the area is known to be nonhazardous.



Caution Do not remove modules unless power has been switched off or the area is known to be nonhazardous.



Caution Substitution of components may impair suitability for Class I, Division 2, or Zone 2.



Caution The system must be installed in an enclosure certified for the intended hazardous (classified) location, having a tool secured cover/door, where a minimum protection of at least IP54 is provided.

Special Conditions for Hazardous Locations Use in Europe and Internationally

The NI 9206 has been evaluated as Ex nA IIC T4 Gc equipment under DEMKO 03 ATEX 0324020X and is IECEx UL 14.0089X certified. Each NI 9206 is marked  II 3G and is suitable for use in Zone 2 hazardous locations, in ambient temperatures of $-40\text{ }^{\circ}\text{C} \leq T_a \leq 70\text{ }^{\circ}\text{C}$. If you are using the NI 9206 in Gas Group IIC hazardous locations, you must use the device in an NI chassis that has been evaluated as Ex nC IIC T4, Ex IIC T4, Ex nA IIC T4, or Ex nL IIC T4 equipment.



Caution Transient protection shall be provided that is set at a level not exceeding 140% of the peak rated voltage value of 85 V at the supply terminals to the equipment.



Caution The system shall only be used in an area of not more than Pollution Degree 2, as defined in IEC/EN 60664-1.



Caution The system shall be mounted in an ATEX/IECEx-certified enclosure with a minimum ingress protection rating of at least IP54 as defined in IEC/EN 60079-15.



Caution The enclosure must have a door or cover accessible only by the use of a tool.

Electromagnetic Compatibility Guidelines

This product was tested and complies with the regulatory requirements and limits for electromagnetic compatibility (EMC) stated in the product specifications. These requirements and limits provide reasonable protection against harmful interference

when the product is operated in the intended operational electromagnetic environment.

This product is intended for use in industrial locations. However, harmful interference may occur in some installations, when the product is connected to a peripheral device or test object, or if the product is used in residential or commercial areas. To minimize interference with radio and television reception and prevent unacceptable performance degradation, install and use this product in strict accordance with the instructions in the product documentation.

Furthermore, any changes or modifications to the product not expressly approved by National Instruments could void your authority to operate it under your local regulatory rules.

Special Conditions for Marine Applications

Some products are Lloyd's Register (LR) Type Approved for marine (shipboard) applications. To verify Lloyd's Register certification for a product, visit ni.com/certification and search for the LR certificate, or look for the Lloyd's Register mark on the product.



Caution In order to meet the EMC requirements for marine applications, install the product in a shielded enclosure with shielded and/or filtered power and input/output ports. In addition, take precautions when designing, selecting, and installing measurement probes and cables to ensure that the desired EMC performance is attained.

Preparing the Environment

Ensure that the environment in which you are using the NI 9206 meets the following specifications.

Operating temperature (IEC 60068-2-1, IEC 60068-2-2)	-40 °C to 70 °C
Operating humidity (IEC 60068-2-78)	10% RH to 90% RH, noncondensing
Pollution Degree	2
Maximum altitude	2,000 m

Indoor use only.



Note Refer to the device datasheet on ni.com/manuals for complete specifications.

NI 9206 Pinout

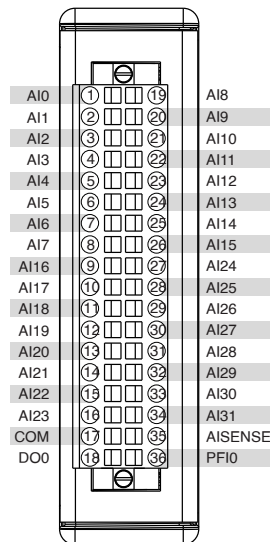

Signal	Description
AI	Analog input signal connection
AISENSE	Reference connection for NRSE measurements
COM	Common reference connection to isolated ground
DO	Digital output signal connection
PFI	Programmable function interface, digital input signal connection

Table 1. Signal Descriptions

Signals

You can connect single-ended or differential signals to the NI 9206. Use a differential measurement configuration to attain more accurate measurements and less noise.

The following table shows the signal pairs that are valid for differential connection configurations with the NI 9206.

Channel	AI +	AI-
0	AI0	AI8
1	AI1	AI9
2	AI2	AI10
3	AI3	AI11
4	AI4	AI12
5	AI5	AI13
6	AI6	AI14
7	AI7	AI15
16	AI16	AI24
17	AI17	AI25
18	AI18	AI26
19	AI19	AI27
20	AI20	AI28
21	AI21	AI29
22	AI22	AI30
23	AI23	AI31

Table 2. Differential Pairs

Connecting Floating Differential Signals

You can connect floating differential signals to the NI 9206.

Figure 2. Connecting Floating Differential Signals to the NI 9206

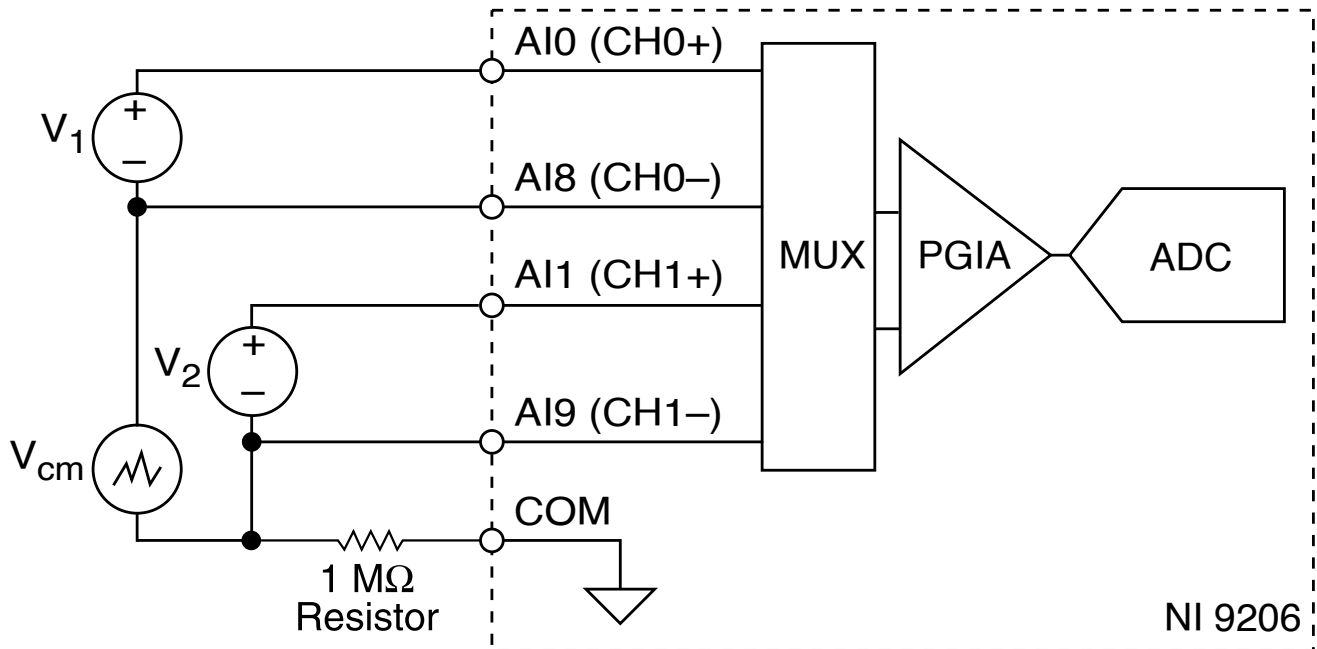

Connecting Grounded Differential Signals

You can connect grounded differential signals to the NI 9206.

Figure 3. Connecting Grounded Differential Signals to the NI 9206

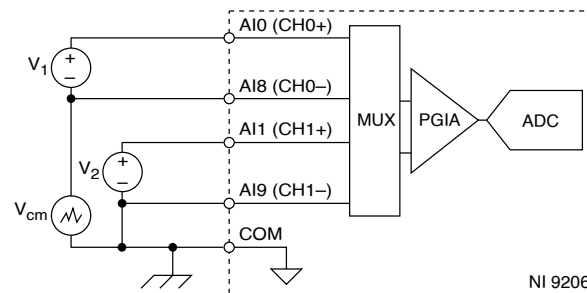

Connecting RSE Voltage Signals

You can connect referenced single-ended (RSE) signals to the NI 9206.

Figure 4. Connecting RSE Voltage Signals

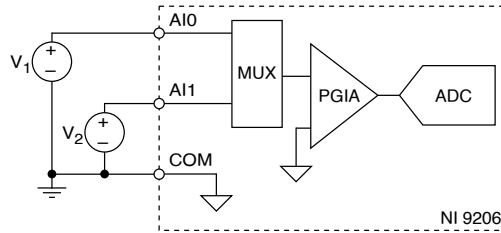

Connecting NRSE Voltage Signals

You can connect non-referenced single-ended (NRSE) signals to the NI 9206.

Figure 5. Connecting an RSE Voltage Signal to the NI 9206

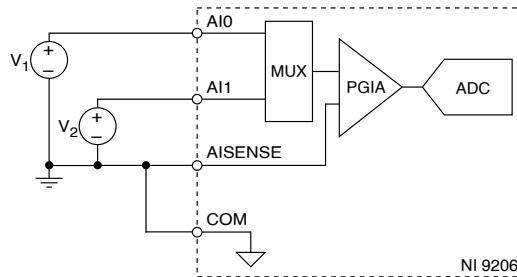

Connecting Fuel Cell Devices

You can connect a fuel cell device to the NI 9206.

Figure 6. Connecting a Fuel Cell Device to the NI 9206

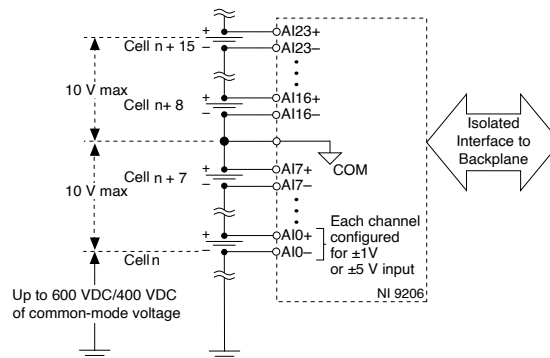

NI 9206 Connection Guidelines

- Make sure that devices you connect to the NI 9206 are compatible with the module specifications.

- You must use 2-wire ferrules to create a secure connection when connecting more than one wire to a single terminal on the NI 9206.
- Push the wire into the terminal when using a solid wire or a stranded wire with a ferrule.
- Open the terminal by pressing the push button when using stranded wire without a ferrule.

Connecting to a Spring-Terminal Connector

What to Use

- NI 9206 spring-terminal connector
- 0.08 mm² to 1.0 mm² (28 AWG to 18 AWG) copper conductor wire with 7 mm (0.28 in.) of insulation stripped from the end
- Flathead screwdriver with a 2.3 mm x 1.0 mm (0.09 in. x 0.04 in.) blade, included with the NI 9206

What to Do

Complete the following steps to connect wires to the spring-terminal connector.

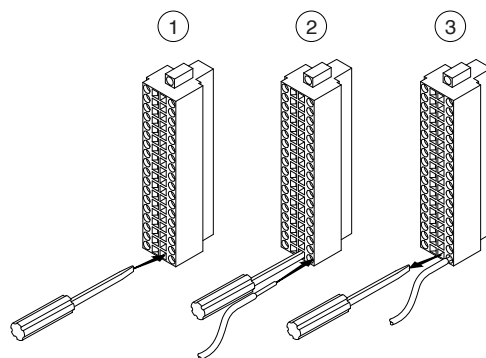

1. Insert the screwdriver into a spring clamp activation slot to open the corresponding connector terminal.
2. Press a wire into the open connector terminal.

3. Remove the screwdriver from the activation slot to clamp the wire into place.

High-Vibration Application Connections

If your application is subject to high vibration, NI recommends that you use the NI 9941 backshell kit to protect connections to the NI 9206.

Where to Go Next

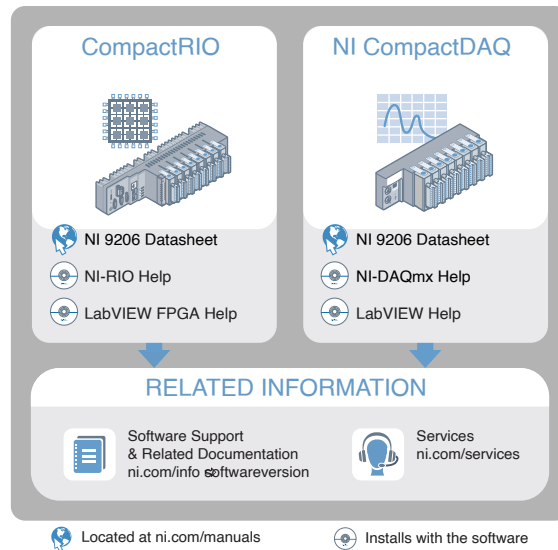

Worldwide Support and Services

The NI website is your complete resource for technical support. At ni.com/support, you have access to everything from troubleshooting and application development self-help resources to email and phone assistance from NI Application Engineers.

Visit ni.com/services for NI Factory Installation Services, repairs, extended warranty, and other services.

Visit ni.com/register to register your NI product. Product registration facilitates technical support and ensures that you receive important information updates from NI.

A Declaration of Conformity (DoC) is our claim of compliance with the Council of the European Communities using the manufacturer's declaration of conformity. This

system affords the user protection for electromagnetic compatibility (EMC) and product safety. You can obtain the DoC for your product by visiting ni.com/certification. If your product supports calibration, you can obtain the calibration certificate for your product at ni.com/calibration.

NI corporate headquarters is located at 11500 North Mopac Expressway, Austin, Texas, 78759-3504. NI also has offices located around the world. For telephone support in the United States, create your service request at ni.com/support or dial 1 866 ASK MYNI (275 6964). For telephone support outside the United States, visit the **Worldwide Offices** section of ni.com/niglobal to access the branch office websites, which provide up-to-date contact information, support phone numbers, email addresses, and current events.