



SMX SERIES SWITCH CARDS

USER'S MANUAL

P/N: 82-0147-000
Released 26 Oct 2022

AMETEK Programmable Power
9250 Brown Deer Road
San Diego, CA 92121, (858) 450-0085

TABLE OF CONTENTS

INTRODUCTION

USER'S MANUAL	1
About AMETEK.....	14
Trademarks.....	14
Exclusion for Documentation.....	14
Contact Information.....	14
Certification.....	15
Warranty Terms.....	15
Product Return Procedure.....	15
GENERAL SAFETY INSTRUCTIONS	17
Terms and Symbols.....	17
Warnings.....	17
SECTION 1	19
INTRODUCTION	19
Overview.....	19
Plug-in Module Installation.....	19
switch card firmware upgrade.....	20
Module Shielding/Grounding.....	22
Application Environments.....	22
Connecting To Embedded Slot-0 PXIe Controller.....	22
DIRECT PCIE REGISTER CONTROL INTERFACE FOR SMX CARDS	24
PXIE PLATFORM	25
VTIPXIE ADVANTAGES	25
SECTION 2	27
SWITCHING OVERVIEW	27
General Purpose Switching.....	27
Power Switching.....	27
Matrix/Multiplexer Switching.....	27
SMX MODULES	29
SECTION 3	32
SMX-2001-10 SWITCH MODULE	32
10-Channel 16 A FORM A (SPST) Switch.....	32
Connector Pins and Signals.....	32
Power Requirements.....	33
Logical Diagram.....	33
SMX-2001-10 Specifications.....	34
GENERAL SPECIFICATIONS	34
SMX-2001-12 SWITCH MODULE	35
12-Channel 16 A FORM A (SPST) Switch.....	35
Connector Pins and Signals.....	35
Power Requirements.....	35
Logical Diagram.....	36
SMX-2001-12 Specifications.....	37
GENERAL SPECIFICATIONS	37
SMX-2001-16 SWITCH MODULE	38
16-Channel 16 A FORM A (SPST) Switch.....	38
Connector Pins and Signals.....	38
Power Requirements.....	38
Logical Diagram.....	39
SMX-2001-16 Specifications.....	40
GENERAL SPECIFICATIONS	40

SMX-2002-10 SWITCH MODULE	41
10-Channel 16 A FORM C (SPDT) Switch	41
Connector Pins and Signals	41
Power Requirements	41
Logical Diagram.....	42
SMX-2002-10 Specifications	43
GENERAL SPECIFICATIONS.....	43
SMX-2002-12 SWITCH MODULE	44
12-Channel 16 A FORM C (SPDT) Switch	44
Connector Pins and Signals	44
Power Requirements	44
Logical Diagram.....	45
SMX-2002-12 Specifications	46
GENERAL SPECIFICATIONS.....	46
SMX-3001 SWITCH MODULE	47
(8) 1 x 8 2-wire fully configurable multiplexer.....	47
Connector Pins and signals.....	47
Logical Diagram.....	49
SMX-3001 Specifications.....	51
GENERAL SPECIFICATIONS.....	51
SMX-3001DS SWITCH MODULE.....	52
(8) 1 x 8 2-wire fully configurable multiplexer.....	52
Connector Pins and Signals	52
Logical Diagram.....	55
SMX-3001DS Specifications	56
GENERAL SPECIFICATIONS.....	56
SMX-3002 SWITCH MODULE	57
(8) 1 x 8 2-wire fixed multiplexer	57
Connector Pins and signals.....	57
Logical Diagram.....	59
SMX-3002 Specifications.....	60
GENERAL SPECIFICATIONS.....	60
SMX-3002DS SWITCH MODULE.....	61
(8) 1 x 8 2-wire fixed multiplexer	61
Connector Pins and Signals	61
Logical Diagram.....	63
SMX-3002DS Specifications	64
GENERAL SPECIFICATIONS.....	64
SMX-3003 SWITCH MODULE	65
(4) 1 x 16 2-wire fixed multiplexer	65
Connector Pins and signals.....	65
Logical Diagram.....	67
SMX-3003 Specifications.....	68
GENERAL SPECIFICATIONS.....	68
SMX-3003DS SWITCH MODULE.....	69
(4) 1 x 16 2-wire fixed multiplexer	69
Connector Pins and Signals	69
Logical Diagram.....	71
SMX-3003DS Specifications	72
GENERAL SPECIFICATIONS.....	72
SMX-3004 SWITCH MODULE	73
(2) 1 x 32 2-wire fixed multiplexer	73
Connector Pins and signals.....	73
Logical Diagram.....	75
SMX-3004 Specifications.....	76
GENERAL SPECIFICATIONS.....	76
SMX-3004DS SWITCH MODULE.....	77

(2) 1 x 32 2-wire fixed multiplexer	77
Connector Pins and Signals	77
Logical Diagram.....	79
SMX-3004DS Specifications	80
GENERAL SPECIFICATIONS	80
SMX-3005 SWITCH MODULE	81
(1) 1 x 64 2-wire fixed multiplexer	81
Connector Pins and signals.....	81
Logical Diagram.....	83
SMX-3005 Specifications.....	84
GENERAL SPECIFICATIONS	84
SMX-3005DS SWITCH MODULE	85
(1) 1 x 64 2-wire fixed multiplexer	85
Connector Pins and Signals	85
Logical Diagram.....	87
SMX-3005DS Specifications	88
GENERAL SPECIFICATIONS	88
SMX-3006 SWITCH MODULE	89
(1) 1 x 128 1-wire fixed multiplexer.....	89
Connector Pins and signals.....	89
Logical Diagram.....	91
SMX-3006 Specifications.....	92
GENERAL SPECIFICATIONS	92
SMX-3007 SWITCH MODULE	93
(2) 1 x 64 1-wire fixed multiplexer	93
Connector Pins and signals.....	93
Logical Diagram.....	96
SMX-3007 Specifications.....	97
GENERAL SPECIFICATIONS	97
SMX-3276, MATRIX MODULE	98
(2) 1 x 38 2-wire fully configurable multiplexer.....	98
Connector Pins and Signals	98
Logical Diagram.....	100
SMX-3276 Specifications.....	101
GENERAL SPECIFICATIONS	101
SMX-3276, MATRIX MODULE	102
(2) 1 x 38 2-wire fully configurable multiplexer.....	102
Connector Pins and Signals	102
Logical Diagram.....	104
SMX-3276DS Specifications	105
GENERAL SPECIFICATIONS	105
SMX-3276, MATRIX MODULE	106
(2) 1 x 76 1-wire fixed multiplexer	106
Connector Pins and Signals	106
Logical Diagram.....	108
SMX-3277 Specifications.....	109
GENERAL SPECIFICATIONS	109
SMX-3276, MATRIX MODULE	110
(2) 1 x 76 1-wire fixed multiplexer	110
Connector Pins and Signals	110
Logical Diagram.....	112
SMX-3277DS Specifications	113
GENERAL SPECIFICATIONS	113
SMX-3276, MATRIX MODULE	114
(2) 1 x 38 2-wire fixed multiplexer	114
Connector Pins and Signals	114
Logical Diagram.....	116

SMX-3278 Specifications.....	117
GENERAL SPECIFICATIONS.....	117
SMX-3276, MATRIX MODULE	118
(2) 1 x 38 2-wire fixed multiplexer.....	118
Connector Pins and Signals.....	118
Logical Diagram.....	120
SMX-3278DS Specifications	121
GENERAL SPECIFICATIONS.....	121
SMX-3276, MATRIX MODULE	122
(1) 1 x 76 2-wire fixed multiplexer.....	122
Connector Pins and Signals.....	122
Logical Diagram.....	124
SMX-3279 Specifications.....	125
GENERAL SPECIFICATIONS.....	125
SMX-3276, MATRIX MODULE	126
(1) 1 x 76 2-wire fixed multiplexer.....	126
Connector Pins and Signals.....	126
Logical Diagram.....	128
SMX-3279DS Specifications	129
GENERAL SPECIFICATIONS.....	129
SMX-3276, MATRIX MODULE	130
(1) 1 x 152 1-wire fixed multiplexer.....	130
Connector Pins and Signals.....	130
Logical Diagram.....	132
SMX-3280 Specifications.....	133
GENERAL SPECIFICATIONS.....	133
SMX-3276, MATRIX MODULE	134
(1) 1 x 152 1-wire fixed multiplexer.....	134
Connector Pins and Signals.....	134
Logical Diagram.....	136
SMX-3280DS Specifications	137
GENERAL SPECIFICATIONS.....	137
SMX-4410, MATRIX MODULE	138
(4) 4x10 2-wire fully configurable Matrix.....	138
Connector Pins and Signals.....	138
Self-Test.....	141
SMX-4410 Specifications.....	147
GENERAL SPECIFICATIONS.....	147
SMX-4410, MATRIX MODULE	148
(4) 4x10 2-wire fixed Matrix.....	148
Connector Pins and Signals.....	148
SMX-4411 Specifications.....	151
GENERAL SPECIFICATIONS.....	151
SMX-4410, MATRIX MODULE	152
(2) 4x20 2-wire fixed Matrix.....	152
Connector Pins and Signals.....	152
SMX-4412 Specifications.....	155
GENERAL SPECIFICATIONS.....	155
SMX-4410, MATRIX MODULE	156
(1) 4x40 2-wire fixed Matrix.....	156
Connector Pins and Signals.....	156
SMX-4413 Specifications.....	159
GENERAL SPECIFICATIONS.....	159
SMX-4410, MATRIX MODULE	160
(2) 8x10 2-wire fixed Matrix.....	160
Connector Pins and Signals.....	160
SMX-4414 Specifications.....	163

GENERAL SPECIFICATIONS	163
SMX-4410, MATRIX MODULE	164
(1) 8x20 2-wire fixed Matrix	164
Connector Pins and Signals	164
SMX-4415 Specifications.....	167
GENERAL SPECIFICATIONS	167
SMX-5001 PLUG-IN MODULE	168
80-Channel 2 Amp Form A (SPST) Switch	168
Connector Pins and Signals	168
Logical Diagram.....	170
GENERAL SPECIFICATIONS	172
SMX-5002 PLUG IN MODULE	173
50-channel form C (SPDT) Switch	173
GENERAL SPECIFICATIONS	176
SMX-5004 PLUG IN MODULE	177
30-channel form C (SPDT) Switch	177
SMX-61XX MODULE– RF MUX – 50 OHM	180
SMX-61xx General Specifications.....	181
GENERAL SPECIFICATIONS	181
SMX-61xx (SMB) RF Specifications.....	181
SMX-61xx (PkZ) RF Specifications.....	181
SMX-6101 MODULE – RF MUX – 50 OHM	182
(10) 1X4 coaxial mux up to 3.8 GHz.....	182
SMX-6101 Connector Pins and Signals	182
SMX-6101 PkZ Logical Diagram.....	184
SMX-6101 SMB Logical Diagram.....	185
SMX-6101 RF Specifications.....	188
SMX-6111 MODULE – RF MUX – 50 OHM	189
(5) 1X4 coaxial mux up to 3.8 GHz.....	189
SMX-6111 Connector Pins and Signals	189
SMX-6111 PkZ Logical Diagram.....	191
SMX-6111 SMB Logical Diagram.....	192
SMX-6111 RF Specifications.....	195
SMX-6106 MODULE – RF MUX – 50 OHM	196
(2) 1X16 coaxial mux up to 2.5 GHz.....	196
SMX-6106 Connector Pins and Signals	196
SMX-6106 PkZ Logical Diagram.....	198
SMX-6106 SMB Logical Diagram.....	199
SMX-6106 RF Specifications.....	201
SMX-6116 MODULE – RF MUX – 50 OHM	202
(1) 1X16 coaxial mux up to 2.5 GHz.....	202
SMX-6116 Connector Pins and Signals	202
SMX-6116 PkZ Logical Diagram.....	204
SMX-6116 SMB Logical Diagram.....	204
SMX-6116 RF Specifications.....	206
SMX-6105 MODULE – RF MUX – 50 OHM	207
(4) 1X8 coaxial mux up to 2.7 GHz.....	207
SMX-6105 Connector Pins and Signals	207
SMX-6105 PkZ Logical Diagram.....	209
SMX-6105 SMB Logical Diagram.....	210
SMX-6105 RF Specifications.....	213
SMX-6115 MODULE – RF MUX – 50 OHM	214
(2) 1X8 coaxial mux up to 2.7 GHz.....	214
SMX-6115 Connector Pins and Signals	214
SMX-6115 PkZ Logical Diagram.....	216
SMX-6115 SMB Logical Diagram.....	216
SMX-6115 RF Specifications.....	219

SMX-6103 MODULE – RF MUX – 50 OHM	220
(1) 1X32 coaxial mux up to 1.5 GHz.....	220
SMX-6103 Connector Pins and Signals	220
SMX-6103 PkZ Logical Diagram.....	222
SMX-6103 SMB Logical Diagram.....	223
SMX-6103 RF Specifications.....	226
SMX-6144 MODULE – RF MATRIX – 50 OHM.....	227
(1) 4X4 coaxial matrix up to 2.0 GHz	227
SMX-6144 Connector Pins and Signals	227
SMX-6144 PkZ Logical Diagram.....	229
SMX-6144 SMB Logical Diagram.....	229
SMX-6144 RF Specifications.....	232
SMX-71XX-XX AND 72XX-XX MW SWITCH	233
SMX-7121-18: SINGLE SLOT MW SW CARD WITH ONE 18 GHz SPDT SWITCH	242
SMX-7122-18: SINGLE SLOT MW SW CARD WITH TWO 18 GHz SPDT SWITCHES	242
SMX-7223-18: DUAL SLOT MW SW CARD WITH THREE 18 GHz SPDT SWITCHES	242
SMX-7224-18: DUAL SLOT MW SW CARD WITH FOUR 18 GHz SPDT SWITCHES	242
SMX-7121-26: SINGLE SLOT MW SW CARD WITH ONE 26.5 GHz SPDT SWITCH	242
SMX-7122-26: SINGLE SLOT MW SW CARD WITH TWO 26.5 GHz SPDT SWITCHES	242
SMX-7223-26: DUAL SLOT MW SW CARD WITH THREE 26.5 GHz SPDT SWITCHES	242
SMX-7224-26: DUAL SLOT MW SW CARD WITH FOUR 26.5 GHz SPDT SWITCHES	242
SMX-7121-40: SINGLE SLOT MW SW CARD WITH ONE 40 GHz SPDT SWITCH	242
SMX-7122-40: SINGLE SLOT MW SW CARD WITH TWO 40 GHz SPDT SWITCHES	243
SMX-7223-40: DUAL SLOT MW SW CARD WITH THREE 40 GHz SPDT SWITCHES	243
SMX-7224-40: DUAL SLOT MW SW CARD WITH FOUR 40 GHz SPDT SWITCHES	243
SMX-7121-50: SINGLE SLOT MW SW CARD WITH ONE 50 GHz SPDT SWITCH	243
SMX-7122-50: SINGLE SLOT MW SW CARD WITH TWO 50 GHz SPDT SWITCHES	243
SMX-7223-50: DUAL SLOT MW SW CARD WITH THREE 50 GHz SPDT SWITCHES	243
SMX-7224-50: DUAL SLOT MW SW CARD WITH FOUR 50 GHz SPDT SWITCHES	243
SMX-7121-67: SINGLE SLOT MW SW CARD WITH ONE 67 GHz SPDT SWITCH	243
SMX-7122-67: SINGLE SLOT MW SW CARD WITH TWO 67 GHz SPDT SWITCHES	243
SMX-7223-67: DUAL SLOT MW SW CARD WITH THREE 67 GHz SPDT SWITCHES	243
SMX-7224-67: DUAL SLOT MW SW CARD WITH FOUR 67 GHz SPDT SWITCHES	244
SMX-7241-06: DUAL SLOT MW SW CARD WITH ONE 06 GHz SP4T SWITCH	244
SMX-7242-06: DUAL SLOT MW SW CARD WITH TWO 06 GHz SP4T SWITCHES	244
SMX-7243-06: DUAL SLOT MW SW CARD WITH THREE 06 GHz SP4T SWITCHES	244
SMX-7241-26: DUAL SLOT MW SW CARD WITH ONE 26.5 GHz SP4T SWITCH	244
SMX-7242-26: DUAL SLOT MW SW CARD WITH TWO 26.5 GHz SP4T SWITCHES	244
SMX-7243-26: DUAL SLOT MW SW CARD WITH THREE 26.5 GHz SP4T SWITCHES	244
SMX-7241-40: DUAL SLOT MW SW CARD WITH ONE 40 GHz SP4T SWITCH	244
SMX-7242-40: DUAL SLOT MW SW CARD WITH TWO 40 GHz SP4T SWITCHES	244
SMX-7243-40: DUAL SLOT MW SW CARD WITH THREE 40 GHz SP4T SWITCHES	245
SMX-7261-06: DUAL SLOT MW SW CARD WITH ONE 06 GHz SP6T SWITCH	245
SMX-7262-06: DUAL SLOT MW SW CARD WITH TWO 06 GHz SP6T SWITCHES	245
SMX-7263-06: DUAL SLOT MW SW CARD WITH THREE 06 GHz SP6T SWITCHES	245
SMX-7261-26: DUAL SLOT MW SW CARD WITH ONE 26.5 GHz SP6T SWITCH	245
SMX-7262-26: DUAL SLOT MW SW CARD WITH TWO 26.5 GHz SP6T SWITCHES	245
SMX-7263-26: DUAL SLOT MW SW CARD WITH THREE 26.5 GHz SP6T SWITCHES	245
SMX-7261-40: DUAL SLOT MW SW CARD WITH ONE 40 GHz SP6T SWITCH	245
SMX-7262-40: DUAL SLOT MW SW CARD WITH TWO 40 GHz SP6T SWITCHES	245
SMX-7263-40: DUAL SLOT MW SW CARD WITH THREE 40 GHz SP6T SWITCHES	246
SMX-72T1-26: DUAL SLOT MW SW CARD WITH ONE 26.5 GHz TRANSFER SWITCH	246
SMX-72T2-26: DUAL SLOT MW SW CARD WITH TWO 26.5 GHz TRANSFER SWITCH.....	246
SMX-72T1-40: DUAL SLOT MW SW CARD WITH ONE 40 GHz TRANSFER SWITCH.....	246
SMX-72T2-40: DUAL SLOT MW SW CARD WITH TWO 40 GHz TRANSFER SWITCH.....	246
SMX-72T1-50: DUAL SLOT MW SW CARD WITH ONE 50 GHz TRANSFER SWITCH.....	246
SMX-72T2-50: DUAL SLOT MW SW CARD WITH TWO 50 GHz TRANSFER SWITCH.....	246

APPENDIX A	248
MAXIMUM NUMBER OF RELAYS OPERATION PER CARD.....	248
APPENDIX B	249
SWITCH CARD ACCESSORIES	249
List of Accessories.....	249
160- pin connector (SMX-300X).....	249
CONNECTOR KIT.....	249
160- pin connector (SMX-327X).....	249
CONNECTOR KIT.....	249
160- pin connector (SMX-5001/SMX-5002).....	249
CONNECTOR KIT.....	249
50- pin connector (SMX-5004).....	250
CONNECTOR KIT.....	250
41-pin Connector(underminated).....	250
ACCESSORIES	250
160-pin Connector (underminated).....	251
ACCESSORIES	251
PkZ Mating Cables and Housing (SMX-61xx).....	252
APPENDIX C	254
MEMORY LISTING AND CLEARING PROCEDURE.....	254
Overview.....	254
APPENDIX D	256
APPENDIX E	257
WEB PAGE OPERATION(SFP)	257
Opening the Web page.....	257
General Web page Operation	257
Index.....	258
Cards	258
Network Configuration.....	259
Time Configuration.....	261
LXI Synchronization.....	262
LXI Identification.....	262
Blink LAN Indicator.....	264
Change Password	264
Upgrade.....	265
Reset.....	265
Reboot.....	266
Switch Cards Soft Front Panels.....	267

TABLE OF FIGURES

FIGURE 1-1: MODULE INSTALLATION (SMX-2002 SHOWN IN CMX09 CHASSIS)	19
FIGURE 1-2: SFP PAGE	20
FIGURE 1-3: SFP UPGRADE PAGE	20
FIGURE 1-4: SELECTING THE SMX UPGRADE FILE	21
FIGURE 1-5: CLICKING SUBMIT TO START UPGRADE	21
FIGURE 1-6: RUNNING UPGRADE	22
FIGURE 2-1: STUB BREAKING RELAYS	28
FIGURE 3-1: SMX-2001-10 FRONT PANEL (FRONT VIEW)	32
FIGURE 3-2: SMX-2001-10 LOGICAL DIAGRAM	33
FIGURE 3-3: MAX. DC LOAD BREAKING CAPACITY	34
FIGURE 3-4: SMX-2001-12 FRONT PANEL (FRONT VIEW)	35
FIGURE 3-5: SMX-2001-12 LOGICAL DIAGRAM	36
FIGURE 3-6: MAX. DC LOAD BREAKING CAPACITY	37
FIGURE 3-7: SMX-2001-16 FRONT PANEL (FRONT VIEW)	38
FIGURE 3-8: SMX-2001-16 LOGICAL DIAGRAM	39
FIGURE 3-9: MAX. DC LOAD BREAKING CAPACITY	40
FIGURE 3-10: SMX-2002-10 FRONT PANEL (FRONT VIEW)	41
FIGURE 3-11: SMX-2002-10 LOGICAL DIAGRAM	42
FIGURE 3-12: MAX. DC LOAD BREAKING CAPACITY	43
FIGURE 3-13: SMX-2002-12 FRONT PANEL (FRONT VIEW)	44
FIGURE 3-14: SMX-2002-12 LOGICAL DIAGRAM	45
FIGURE 3-15: MAX. DC LOAD BREAKING CAPACITY	46
FIGURE 3-16: SMX-3001 FRONT PANEL CONNECTOR PINS (FRONT VIEW)	47
FIGURE 3-17: SMX-3001 LOGICAL DIAGRAM	49
FIGURE 3-18: SMX-3001DS FRONT PANEL (FRONT VIEW)	52
FIGURE 3-19: SMX-3001DS CARD (ANGULAR VIEW)	53
FIGURE 3-20: SMX-3001DS LOGICAL DIAGRAM	55
FIGURE 3-21: SMX-3002 FRONT PANEL CONNECTOR PINS (FRONT VIEW)	57
FIGURE 3-22: SMX-3002 LOGICAL DIAGRAM	59
FIGURE 3-23: SMX-3002DS FRONT PANEL (FRONT VIEW)	61
FIGURE 3-24: SMX-3002DS LOGICAL DIAGRAM	63
FIGURE 3-25: SMX-3003 FRONT PANEL CONNECTOR PINS (FRONT VIEW)	65
FIGURE 3-26: SMX-3003 LOGICAL DIAGRAM	67
FIGURE 3-27: SMX-3003DS FRONT PANEL (FRONT VIEW)	69
FIGURE 3-28: SMX-3003DS LOGICAL DIAGRAM	71
FIGURE 3-29: SMX-3004 FRONT PANEL CONNECTOR PINS (FRONT VIEW)	73
FIGURE 3-30: SMX-3004 LOGICAL DIAGRAM	75
FIGURE 3-31: SMX-3004DS FRONT PANEL (FRONT VIEW)	77
FIGURE 3-32: SMX-3004DS LOGICAL DIAGRAM	79
FIGURE 3-33: SMX-3005 FRONT PANEL CONNECTOR PINS (FRONT VIEW)	81
FIGURE 3-34: SMX-3005 LOGICAL DIAGRAM	83
FIGURE 3-35: SMX-3005DS FRONT PANEL (FRONT VIEW)	85
FIGURE 3-36: SMX-3005DS LOGICAL DIAGRAM	87
FIGURE 3-37: SMX-3006 FRONT PANEL CONNECTOR PINS (FRONT VIEW)	89
FIGURE 3-38: SMX-3006 LOGICAL DIAGRAM	91
FIGURE 3-39: SMX-3007 FRONT PANEL CONNECTOR PINS (FRONT VIEW)	93
FIGURE 3-40: SMX-3007 LOGICAL DIAGRAM	96
FIGURE 3-41: SMX-3276 FRONT PANEL CONNECTOR (FRONT VIEW)	98
FIGURE 3-42: SMX-3276 LOGICAL DIAGRAM	100
FIGURE 3-43: SMX-3276DS FRONT PANEL CONNECTOR (FRONT VIEW)	102
FIGURE 3-44: SMX-3276DS LOGICAL DIAGRAM	104
FIGURE 3-45: SMX-3277 FRONT PANEL CONNECTOR (FRONT VIEW)	106
FIGURE 3-46: SMX-3277 LOGICAL DIAGRAM	108
FIGURE 3-47: SMX-3277DS FRONT PANEL CONNECTOR (FRONT VIEW)	110

FIGURE 3-48: SMX-3277DS LOGICAL DIAGRAM	112
FIGURE 3-49: SMX-3278 FRONT PANEL CONNECTOR (FRONT VIEW)	114
FIGURE 3-50: SMX-3278 LOGICAL DIAGRAM	116
FIGURE 3-51: SMX-3278DS FRONT PANEL CONNECTOR (FRONT VIEW)	118
FIGURE 3-52: SMX-3278DS LOGICAL DIAGRAM	120
FIGURE 3-53: SMX-3279 FRONT PANEL CONNECTOR (FRONT VIEW)	122
FIGURE 3-54: SMX-3279 LOGICAL DIAGRAM	124
FIGURE 3-55: SMX-3279DS FRONT PANEL CONNECTOR (FRONT VIEW)	126
FIGURE 3-56: SMX-3279DS LOGICAL DIAGRAM	128
FIGURE 3-57: SMX-3280 FRONT PANEL CONNECTOR (FRONT VIEW)	130
FIGURE 3-58: SMX-3280 LOGICAL DIAGRAM	132
FIGURE 3-59: SMX-3280DS FRONT PANEL CONNECTOR (FRONT VIEW)	134
FIGURE 3-60: SMX-3280DS LOGICAL DIAGRAM	136
FIGURE 3-61: SMX-4410 FRONT PANEL (FRONT VIEW)	138
FIGURE 3-62: SMX-4410 LOGICAL DIAGRAM	140
FIGURE 3-63: SFP MAIN SCREEN	141
FIGURE 3-64: SFP- DEVICE/CARD SELECTION	141
FIGURE 3-65: SMX-4410 SFP SCREEN- SELFTEST	142
FIGURE 3-66: SMX-4410 SELFTEST-MAIN BOARD RELAY LOCATION PAGE	142
FIGURE 3-67: SMX-4410 SELFTEST-MEZZANINE BOARD RELAY LOCATION PAGE	143
FIGURE 3-68: SMX-4410 SELFTEST-INITIATE SELF TEST	143
FIGURE 3-69: SMX-4410 SELFTEST-RUNNING	144
FIGURE 3-70: SMX-4410 SELFTEST-STATUS SUCCESS	144
FIGURE 3-71: SMX-4410 SELFTEST-SUMMARY	145
FIGURE 3-72: SMX-4410 SELFTEST-ODOMETERS	145
FIGURE 3-73: SMX-4410 SELF-TEST - RELAY LOCATION (MAIN BOARD) SCREEN, POST SELF-TEST INDICATING THE STATUS	146
FIGURE 3-74: SMX-4410 SELF-TEST - RELAY LOCATION (MEZZANINE BOARD) SCREEN, POST SELF-TEST INDICATING THE STATUS	146
FIGURE 3-75: SMX-4411 FRONT PANEL (FRONT VIEW)	148
FIGURE 3-76: SMX-4411 LOGICAL DIAGRAM	150
FIGURE 3-77: SMX-4412 FRONT PANEL (FRONT VIEW)	152
FIGURE 3-78: SMX-4412 LOGICAL DIAGRAM	154
FIGURE 3-79: SMX-4413 FRONT PANEL (FRONT VIEW)	156
FIGURE 3-80: SMX-4413 LOGICAL DIAGRAM	158
FIGURE 3-81: SMX-4414 FRONT PANEL (FRONT VIEW)	160
FIGURE 3-82: SMX-4414 LOGICAL DIAGRAM	162
FIGURE 3-83: SMX-4415 FRONT PANEL (FRONT VIEW)	164
FIGURE 3-84: SMX-4415 LOGICAL DIAGRAM	166
FIGURE 3-85: SMX-5001 FRONT PANEL (FRONT VIEW)	168
FIGURE 3-86: SMX-5001 LOGICAL DIAGRAM	170
FIGURE 3-87: SMX-5002 CONNECTOR PIN LOCATIONS	173
FIGURE 3-88: SMX-5002 CARD VIEW	173
FIGURE 3-89: SMX-5002 SCHEMATIC VIEW	175
FIGURE 3-89B: SMX-5004 SCHEMATIC VIEW	178
FIGURE 3-89C: SMX-5004 SWITCHING VOLTAGE AND CURRENT	179
FIGURE 3-90: SMX-6101 FRONT PANEL LAYOUT (SMB CONNECTOR -LEFT IMAGE, PkZ CONNECTOR- RIGHT IMAGE)	182
FIGURE 3-91: SMX-6101 PkZ LOGICAL DIAGRAM	184
FIGURE 3-92: SMX-6101 SMB LOGICAL DIAGRAM	185
FIGURE 3-93: SMX-6101 SMB BANDWIDTH GRAPH	186
FIGURE 3-94: SMX-6101 PkZ BANDWIDTH GRAPH	186
FIGURE 3-95: SMX-6101 SMB VSWR GRAPH	187
FIGURE 3-96: SMX-6101 PkZ VSWR GRAPH	187
FIGURE 3-97: SMX-6111 FRONT PANEL LAYOUT(SMB CONNECTOR -LEFT IMAGE, PkZ CONNECTOR- RIGHT IMAGE)	189
FIGURE 3-98: SMX-6111 PkZ LOGICAL DIAGRAM	191

FIGURE 3-99: SMX-6111 SMB LOGICAL DIAGRAM	192
FIGURE 3-100: SMX-6111 SMB BANDWIDTH GRAPH.....	193
FIGURE 3-101: SMX-6111 PkZ BANDWIDTH GRAPH	193
FIGURE 3-102: SMX-6111 SMB VSWR GRAPH.....	194
FIGURE 3-103: SMX-6111 PkZ VSWR GRAPH	194
FIGURE 3-104: SMX-6106 FRONT PANEL LAYOUT (SMB CONNECTOR -LEFT IMAGE, PkZ CONNECTOR- RIGHT IMAGE)	196
FIGURE 3-105: SMX-6106 PkZ LOGICAL DIAGRAM	198
FIGURE 3-106: SMX-6106 SMB LOGICAL DIAGRAM	199
FIGURE 3-107: SMX-6106 SMB BANDWIDTH GRAPH.....	200
FIGURE 3-108: SMX-6106 PkZ BANDWIDTH GRAPH	200
FIGURE 3-109: SMX-6106 SMB AND PkZ VSWR GRAPH	201
FIGURE 3-110: SMX-6116 FRONT PANEL LAYOUT (SMB CONNECTOR -LEFT IMAGE, PkZ CONNECTOR- RIGHT IMAGE)	202
FIGURE 3-111: SMX-6116 PkZ LOGICAL DIAGRAM	204
FIGURE 3-112: SMX-6116 SMB LOGICAL DIAGRAM	204
FIGURE 3-113: SMX-6116 SMB BANDWIDTH GRAPH.....	205
FIGURE 3-114: SMX-6116 PkZ BANDWIDTH GRAPH	205
FIGURE 3-115: SMX-6116 SMB AND PkZ VSWR GRAPH	206
FIGURE 3-116: SMX-6105 FRONT PANEL LAYOUT(SMB CONNECTOR -LEFT IMAGE, PkZ CONNECTOR- RIGHT IMAGE)	207
FIGURE 3-117: SMX-6105 PkZ LOGICAL DIAGRAM	209
FIGURE 3-118: SMX-6105 SMB LOGICAL DIAGRAM	210
FIGURE 3-119: SMX-6105 SMB BANDWIDTH GRAPH.....	211
FIGURE 3-120: SMX-6105 PkZ BANDWIDTH GRAPH	211
FIGURE 3-121: SMX-6105 SMB VSWR GRAPH.....	212
FIGURE 3-122: SMX-6105 PkZ VSWR GRAPH	212
FIGURE 3-123: SMX-6115 FRONT PANEL LAYOUT(SMB CONNECTOR -LEFT IMAGE, PkZ CONNECTOR- RIGHT IMAGE)	214
FIGURE 3-124: SMX-6115 PkZ LOGICAL DIAGRAM	216
FIGURE 3-125: SMX-6115 SMB LOGICAL DIAGRAM	216
FIGURE 3-126: SMX-6115 SMB BANDWIDTH GRAPH.....	217
FIGURE 3-127: SMX-6115 PkZ BANDWIDTH GRAPH	217
FIGURE 3-128: SMX-6115 SMB VSWR GRAPH.....	218
FIGURE 3-129: SMX-6115 PkZ VSWR GRAPH	218
FIGURE 3-130: SMX-6103 FRONT PANEL LAYOUT (SMB CONNECTOR -LEFT IMAGE, PkZ CONNECTOR- RIGHT IMAGE)	220
FIGURE 3-131: SMX-6103 PkZ LOGICAL DIAGRAM	222
FIGURE 3-132: SMX-6103 SMB LOGICAL DIAGRAM	223
FIGURE 3-133: SMX-6103 SMB BANDWIDTH GRAPH.....	224
FIGURE 3-134: SMX-6103 PkZ BANDWIDTH GRAPH	224
FIGURE 3-135: SMX-6103 SMB VSWR GRAPH.....	225
FIGURE 3-136: SMX-6103 PkZ VSWR GRAPH	225
FIGURE 3-137: SMX-6144 FRONT PANEL LAYOUT(SMB CONNECTOR -LEFT IMAGE, PkZ CONNECTOR- RIGHT IMAGE)	227
FIGURE 3-138: SMX-6144 PkZ LOGICAL DIAGRAM	229
FIGURE 3-139: SMX-6144 SMB LOGICAL DIAGRAM	229
FIGURE 3-140: SMX-6144 SMB BANDWIDTH GRAPH.....	230
FIGURE 3-141: SMX-6144 PkZ BANDWIDTH GRAPH	230
FIGURE 3-142: SMX-6144 SMB VSWR GRAPH.....	231
FIGURE 3-143: SMX-6144 PkZ VSWR GRAPH	231
FIGURE 3-144: SMX CARDS WEB PAGE.....	259
FIGURE 3-145: TIME CONFIGURATION PAGE	261
FIGURE 3-146: SMX-2002 SWITCH CARD SFP PAGE	268
FIGURE 3-147: SMX-2002 SWITCH CARD SAVED STATES	268
FIGURE 3-14834: SMX-2002 SWITCH CARD PATHS.....	269
FIGURE 3-14935: SMX-2002 SWITCH CARD DEVICE INFO	269

LIST OF TABLES

TABLE 2-1: SMX-PLUG IN MODELS.....	31
TABLE 3-1: CONNECTOR PINS & SIGNAL ASSIGNMENTS	33
TABLE 3-2: CONNECTOR PINS & SIGNAL ASSIGNMENTS	36
TABLE 3-3: CONNECTOR PINS & SIGNAL ASSIGNMENTS	39
TABLE 3-4: CONNECTOR PINS & SIGNAL ASSIGNMENTS	42
TABLE 3-5: CONNECTOR PINS & SIGNAL ASSIGNMENTS	45
TABLE 3-6: SMX-3001 CONNECTOR PINS & SIGNAL ASSIGNMENTS.....	48
TABLE 3-7: EX1200-TB160-3 TERMINAL BLOCK TO SMX-3001 PIN MAPPING	50
TABLE 3-8: SMX-3001DS CONNECTOR PINS & SIGNAL ASSIGNMENTS	54
TABLE 3-9: SMX-3002 PINS & SIGNAL ASSIGNMENTS	58
TABLE 3-10: SMX-3002DS CONNECTOR PINS & SIGNAL ASSIGNMENTS	62
TABLE 3-11: SMX-3003 PINS & SIGNAL ASSIGNMENTS	66
TABLE 3-12: SMX-3003DS CONNECTOR PINS & SIGNAL ASSIGNMENTS	70
TABLE 3-13: SMX-3004 PINS & SIGNAL ASSIGNMENTS	74
TABLE 3-14: SMX-3004DS CONNECTOR PINS & SIGNAL ASSIGNMENTS	78
TABLE 3-15: SMX-3005 PINS & SIGNAL ASSIGNMENTS	82
TABLE 3-16: SMX-3005DS CONNECTOR PINS & SIGNAL ASSIGNMENTS	86
TABLE 3-17: SMX-3006 PINS & SIGNAL ASSIGNMENTS	90
TABLE 3-18: SMX-3007 PINS & SIGNAL ASSIGNMENTS	94
TABLE 3-19: SMX-3276 CONNECTOR PINS & SIGNAL ASSIGNMENTS.....	99
TABLE 3-20: SMX-3276DS CONNECTOR PINS & SIGNAL ASSIGNMENTS	103
TABLE 3-21: SMX-3277 CONNECTOR PINS & SIGNAL ASSIGNMENTS.....	107
TABLE 3-22: SMX-3277DS CONNECTOR PINS & SIGNAL ASSIGNMENTS	111
TABLE 3-23: SMX-3278 CONNECTOR PINS & SIGNAL ASSIGNMENTS.....	115
TABLE 3-24: SMX-3278DS CONNECTOR PINS & SIGNAL ASSIGNMENTS	119
TABLE 3-25: SMX-3279 CONNECTOR PINS & SIGNAL ASSIGNMENTS.....	123
TABLE 3-26: SMX-3279DS CONNECTOR PINS & SIGNAL ASSIGNMENTS	127
TABLE 3-27: SMX-3280 CONNECTOR PINS & SIGNAL ASSIGNMENTS.....	131
TABLE 3-28: SMX-3280DS CONNECTOR PINS & SIGNAL ASSIGNMENTS	135
TABLE 3-29: SMX-4410 CONNECTOR PINS & SIGNAL ASSIGNMENTS.....	139
TABLE 3-30: SMX-4411 CONNECTOR PINS & SIGNAL ASSIGNMENTS.....	149
TABLE 3-31: SMX-4412 CONNECTOR PINS & SIGNAL ASSIGNMENTS.....	153
TABLE 3-32: SMX-4413 CONNECTOR PINS & SIGNAL ASSIGNMENTS.....	157
TABLE 3-33: SMX-4414 CONNECTOR PINS & SIGNAL ASSIGNMENTS.....	161
TABLE 3-34: SMX-4415 CONNECTOR PINS & SIGNAL ASSIGNMENTS.....	165
TABLE 3-35: CONNECTOR PINS & SIGNAL ASSIGNMENTS	169
TABLE 3-36: EX1200-TB160SE TERMINAL BLOCK TO SMX-5001 PIN MAPPING	171
TABLE 3-37: SMX-5002 PIN/ SIGNAL ASSIGNMENT	174
TABLE 3-37A: SMX-5004 PIN/ SIGNAL ASSIGNMENT	178
TABLE 3-38: SMX-61XX MODEL SERIES	180
TABLE 3-39: SMX-6XXX MODEL SERIES RF SPECIFICATION (SMB CONNECTOR)	181
TABLE 3-40: SMX-6XXX MODEL SERIES RF SPECIFICATION (PkZ CONNECTOR).....	181
TABLE 3-41: SMX-6101 PkZ CONNECTOR PINS & SIGNAL ASSIGNMENTS	183
TABLE 3-42: SMX- 6101 SMB PIN MAPPING	183
TABLE 3-43: SMX-6101 MODEL RF SPECIFICATIONS	188
TABLE 3-44: SMX-6111 PkZ CONNECTOR PINS & SIGNAL ASSIGNMENTS	190
TABLE 3-45: SMX- 6111 SMB PIN MAPPING	190
TABLE 3-46: SMX-6111 MODEL RF SPECIFICATIONS	195
TABLE 3-47: SMX-6106 PkZ CONNECTOR PINS & SIGNAL ASSIGNMENTS	197
TABLE 3-48: SMX- 6106 SMB PIN MAPPING	197
TABLE 3-49: SMX-6106 MODEL RF SPECIFICATIONS	201
TABLE 3-50: SMX-6116 PkZ CONNECTOR PINS & SIGNAL ASSIGNMENTS	203

TABLE 3-51: SMX- 6116 SMB PIN MAPPING	203
TABLE 3-52: SMX-6116 MODEL RF SPECIFICATIONS	206
TABLE 3-53: SMX-6105 PkZ CONNECTOR PINS & SIGNAL ASSIGNMENTS	208
TABLE 3-54: SMX- 6105 SMB PIN MAPPING	208
TABLE 3-55: SMX-6105 MODEL RF SPECIFICATIONS	213
TABLE 3-56: SMX-6115 PkZ CONNECTOR PINS & SIGNAL ASSIGNMENTS	215
TABLE 3-57: SMX- 6115 SMB PIN MAPPING	215
TABLE 3-58: SMX-6115 MODEL RF SPECIFICATIONS	219
TABLE 3-59: SMX-6103 PkZ CONNECTOR PINS & SIGNAL ASSIGNMENTS	221
TABLE 3-60: SMX- 6103 SMB PIN MAPPING	221
TABLE 3-61: SMX-6103 MODEL RF SPECIFICATIONS	226
TABLE 3-62: SMX-6144 PkZ CONNECTOR PINS & SIGNAL ASSIGNMENTS	228
TABLE 3-63: SMX- 6144 SMB PIN MAPPING	228
TABLE 3-64: SMX-6144 MODEL RF SPECIFICATIONS	232
TABLE 3-65: SMX-7x2x-xx SPDT SWITCH MODELS	233
TABLE 3-66: SMX-7x4x-xx/7x6x-xx/7xTx-xx SP4T/SP6T/TRANSFER SWITCH MODELS	234
TABLE 3-67: SMX-7x2x-xx SPDT SW SPECIFICATIONS.....	236

ABOUT AMETEK

AMETEK Programmable Power, Inc., a Division of AMETEK, Inc., is a global leader in the design and manufacture of precision, programmable power supplies for R&D, test and measurement, process control, power bus simulation and power conditioning applications across diverse industrial segments. From bench top supplies to rackmounted industrial power subsystems, AMETEK Programmable Power is the proud manufacturer of Elgar, Sorensen, California Instruments, Amrel brand power supplies. Also VTI Instruments brand which delivers precision modular instrumentation and systems for electronic signal distribution, acquisition, and monitoring, used in the world's most demanding test applications.

AMETEK, Inc. is a leading global manufacturer of electronic instruments and electromechanical devices with annualized sales of \$5 billion. The Company has over 17,000 colleagues working at nearly 150 manufacturing facilities and nearly 150 sales and service centers in the United States and 30 other countries around the world.

TRADEMARKS

AMETEK is a registered trademark of AMETEK, Inc. VTI Instruments is a trademark owned by AMETEK, Inc. Other trademarks, registered trademarks, and product names are the property of their respective owners and are used herein for identification purposes only.

Notice of Copyright

SMX Series Switch Cards User Manual © 2018 AMETEK Programmable Power, Inc. All rights reserved.

EXCLUSION FOR DOCUMENTATION

UNLESS SPECIFICALLY AGREED TO IN WRITING, AMETEK PROGRAMMABLE POWER, INC. ("AMETEK"):

- (a) MAKES NO WARRANTY AS TO THE ACCURACY, SUFFICIENCY OR SUITABILITY OF ANY TECHNICAL OR OTHER INFORMATION PROVIDED IN ITS MANUALS OR OTHER DOCUMENTATION.
- (b) ASSUMES NO RESPONSIBILITY OR LIABILITY FOR LOSSES, DAMAGES, COSTS OR EXPENSES, WHETHER SPECIAL, DIRECT, INDIRECT, CONSEQUENTIAL OR INCIDENTAL, WHICH MIGHT ARISE OUT OF THE USE OF SUCH INFORMATION. THE USE OF ANY SUCH INFORMATION WILL BE ENTIRELY AT THE USER'S RISK, AND
- (c) GIVES NOTIFICATION THAT, IF THIS MANUAL IS IN ANY LANGUAGE OTHER THAN ENGLISH, ALTHOUGH STEPS HAVE BEEN TAKEN TO MAINTAIN THE ACCURACY OF THE TRANSLATION, THE ACCURACY CANNOT BE GUARANTEED. APPROVED AMETEK CONTENT IS WITHIN THE ENGLISH LANGUAGE VERSION, WHICH IS POSTED AT WWW.PROGRAMMABLEPOWER.COM.

CONTACT INFORMATION

Telephone: +1 800 733 5427 (toll free in North America)
+1 858 450 0085 (direct)
Fax: +1 858 458 0267
Email: sales.ppd@ametek.com
service.ppd@ametek.com
Web: www.powerandtest.com

CERTIFICATION

VTI Instruments (VTI) certifies that this product met its published specifications at the time of shipment from the factory. VTI further certifies that its calibration measurements are traceable to the United States National Institute of Standards and Technology (formerly National Bureau of Standards), to the extent allowed by that organization's calibration facility, and to the calibration facilities of other International Standards Organization members.

WARRANTY TERMS

The product referred to herein is warranted against defects in material and workmanship for a period of three years from the receipt date of the product at customer's facility.

AMETEK Programmable Power, Inc. ("AMETEK"), provides this written warranty covering the Product stated above, and if the Buyer discovers and notifies AMETEK in writing of any defect in material or workmanship within the applicable warranty period stated above, then AMETEK may, at its option: repair or replace the Product; or issue a credit note for the defective Product; or provide the Buyer with replacement parts for the Product.

The Buyer will, at its expense, return the defective Product or parts thereof to AMETEK in accordance with the return procedure specified below. AMETEK will, at its expense, deliver the repaired or replaced Product or parts to the Buyer. Any warranty of AMETEK will not apply if the Buyer is in default under the Purchase Order Agreement or where the Product, or any part thereof, is as follows:

- damaged by misuse, accident, negligence or failure to maintain the same as specified or required by AMETEK;
- damaged by modifications, alterations or attachments thereto which are not authorized by AMETEK;
- installed or operated contrary to the instructions of AMETEK;
- opened, modified, or disassembled in any way without AMETEK's consent;
- used in combination with items, articles or materials not authorized by AMETEK.

The Buyer may not assert any claim that the Products are not in conformity with any warranty until the Buyer has made all payments to AMETEK provided for in the Purchase Order Agreement.

PRODUCT RETURN PROCEDURE

Request a Return Material Authorization (RMA) number from the repair facility (**must be done in the country in which it was purchased**):

- **In the USA**, contact the AMETEK Customer Service Department prior to the return of the product to AMETEK for repair:
Telephone: 800-733-5427, ext. 2295 or ext. 2463 (toll free North America)
858-450-0085, ext. 2295 or ext. 2463 (direct)
- <https://www.powerandtest.com/service-and-support/rma/rma-request-form>.

When requesting an RMA, have the following information ready:

- Model number
- Serial number
- Description of the problem

NOTE: Unauthorized returns will not be accepted and will be returned at the shipper's expense.

NOTE: A returned product found upon inspection by AMETEK to be in specification is subject to an evaluation fee and applicable freight charges.



Declaration of Conformity

This is to declare that the product listed below conforms to the relevant requirements of the Electromagnetic Compatibility directive (European Council directive 2014/30/EU; generally referred to as the EMC directive), to the requirements of the Low Voltage directive 2014/35/EU, dated 26 February 2014, and to the RoHS2 Directive (European Council directive 2011/65/EU dated 08 June 2011). In substantiation, the products were tested and or evaluated to the standards shown below.

Product Type	Product Model Number(s)	Conforming to Standards:
Switch cards	<p style="text-align: center;">SMX series SMX-(XXXXXX)-(YYY), where XXXXXX, and YYY may be any combination of alpha numeric characters from 0 to 999999, and AAAAAA to ZZZZZZ denoting non safety critical options or configurations.</p>	<p>EN 61326-1:2013 EN 61010-1:2010 EN 50581-1:2012</p>
Signature: 		Date: 1/18/19
Name: Barry Palmatier Title: Compliance Engineer		First Issued: January 18, 2019 Doc. Part No:

Ametek Programmable Power, 9250 Brown Deer Rd., San Diego, CA 92121-2294 USA
 Telephone: USA 858-450-0085, 800-733-5427 FAX: USA 858-458-0257

GENERAL SAFETY INSTRUCTIONS

Review the following safety precautions to avoid bodily injury and/or damage to the product. These precautions must be observed during all phases of operation or service of this product. Failure to comply with these precautions, or with specific warnings elsewhere in this manual, violates safety standards of design, manufacture, and intended use of the product.

Service should only be performed by qualified personnel.

TERMS AND SYMBOLS

These terms may appear in this manual:

- WARNING** Indicates that a procedure or condition may cause bodily injury or death.
- CAUTION** Indicates that a procedure or condition could possibly cause damage to equipment or loss of data.

These symbols may appear on the product:



ATTENTION - Important safety instructions



Frame or chassis ground



Indicates that the product was manufactured after August 13, 2005. This mark is placed in accordance with *EN 50419, Marking of electrical and electronic equipment in accordance with Article 11(2) of Directive 2002/96/EC (WEEE)*. End-of-life product can be returned to VTI by obtaining an RMA number. Fees for takeback and recycling will apply if not prohibited by national law.

WARNINGS

Follow these precautions to avoid injury or damage to the product:

- Use Proper Power Cord** To avoid hazard, only use the power cord specified for this product.
- Use Proper Power Source** To avoid electrical overload, electric shock, or fire hazard, do not use a power source that applies other than the specified voltage.
- Power Consumption** Prior to using the SMX series switch cards, it is imperative that the power consumption of all cards that will be installed in the mainframe be calculated on all power supply rails. Power consumption information is provided in Appendix A. *Failure to do so may result in damaging the switch card and the mainframe.*

WARNINGS (CONT.)**Avoid Electric Shock**

To avoid electric shock or fire hazard, do not operate this product with the covers removed. Do not connect or disconnect any cable, probes, test leads, etc. while they are connected to a voltage source. Remove all power and unplug unit before performing any service. *Service should only be performed by qualified personnel.*

Ground the Product

This product is grounded through the grounding conductor of the power cord. To avoid electric shock, the grounding conductor must be connected to earth ground.

Operating Conditions

To avoid injury, electric shock or fire hazard:

- Do not operate in wet or damp conditions.
- Do not operate in an explosive atmosphere.
- Operate or store only in specified temperature range.
- Provide proper clearance for product ventilation to prevent overheating.
- DO NOT operate if any damage to this product is suspected. *Product should be inspected or serviced only by qualified personnel.*

Improper Use

The operator of this instrument is advised that if the equipment is used in a manner not specified in this manual, the protection provided by the equipment may be impaired. Conformity is checked by inspection.

SECTION 1

INTRODUCTION

OVERVIEW

Signal switching is at the heart of every automated test system. It is responsible for routing signals of interest between test system instruments and the device under test (DUT). The purpose of the testing is to improve product quality. The switch distributes instrument I/O, which can reduce overall system cost. Since switching is effectively an extension of the instrument, it should be transparent to the overall system. SMX switching products employ extensive signal shielding and high-quality relays to ensure that the test system is “minimally aware” of the switch’s presence.

PLUG-IN MODULE INSTALLATION

SMX series switch cards can be installed in VTI’s CMX (CMX09, CMX18 with EMX-2500 controller card) series PXIe mainframe or any other standard PXIe mainframe. The mainframe operates on 90 V to 250 V at 50 Hz/60 Hz which is used to supply the cards the dc voltages required for the cards to function properly. Before installing a plug-in module into an SMX series mainframe, make sure that the mainframe is powered down. Insert the module into the base unit by orienting the module so that the circuit board of the module can be inserted into the slot of the base unit. Position the cover so that it fits into the module’s slot groove. Once the module is properly aligned, push the module back and firmly insert it into the backplane connector.

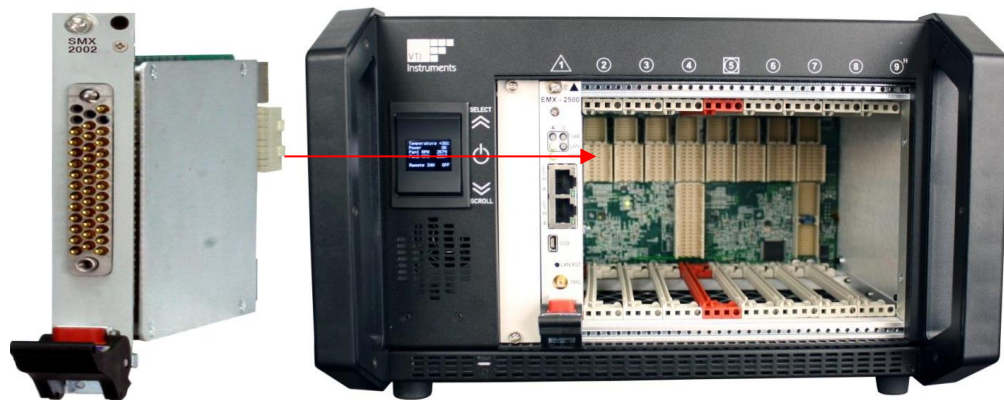

FIGURE 1-1: MODULE INSTALLATION (SMX-2002 SHOWN IN CMX09 CHASSIS)

NOTE

To maximize air flow for cooling, blanking panels (P/N: **70-0463-901R**) should be installed into the empty slots of CMX mainframes.

The maximum safe voltage for an CMX system is determined by the plug-in card with the lowest voltage rating.

For detailed information on CMX09 mainframe please refer “CMX09-Manual Product Manual- 82-0142-000” from Mainframes and Controller section at www.powerandtest.com/ate-data-acq/platforms/pxi-express/mainframes-and-controllers/cm09.

For detailed information on CMX18 mainframe please refer Mainframes and Controller section at www.powerandtest.com/ate-data-acq/platforms/pxi-express/mainframes-and-controllers/cmx18.

For detailed information on EMX-2500 controller please refer “EMX-2500 Product Manual – 82-0144-000” from Mainframes and Controller section at <https://www.powerandtest.com/ate-data-acq/platforms/pxi-express/mainframes-and-controllers/emx2500> website

SWITCH CARD FIRMWARE UPGRADE

To upgrade switch card firmware type in the IP address of the instrument in any web browser. If a CMX09 chassis is used, the IP address can be retrieved from the display of the smart switch in the front panel of the chassis.



FIGURE 1-2: SFP PAGE

Click on the Upgrade button.



FIGURE 1-3: SFP UPGRADE PAGE

Select the folder in which “**SMX_upgrade.img**” file is kept.

Latest Firmware image can be downloaded from “DOCUMENTS AND DOWNLOAD” section of respective SMX-Model from <https://www.powerandtest.com/ate-data-acq/platforms/pxi-express/switching>

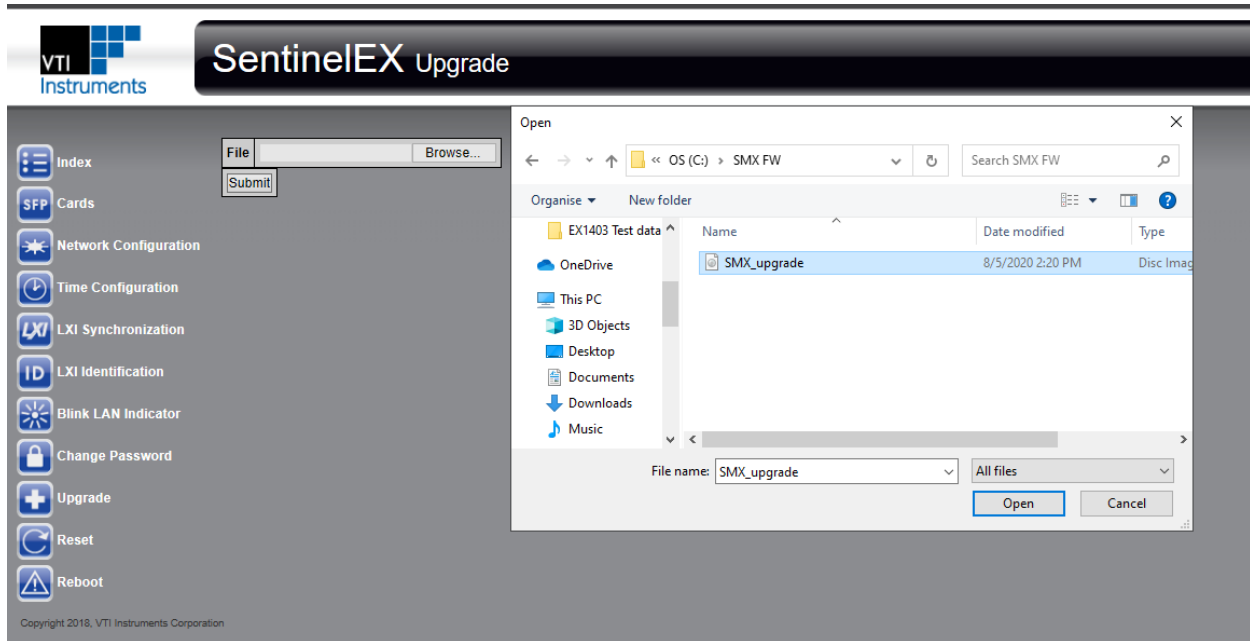

FIGURE 1-4: SELECTING THE SMX UPGRADE FILE

Select this file and click the submit button.

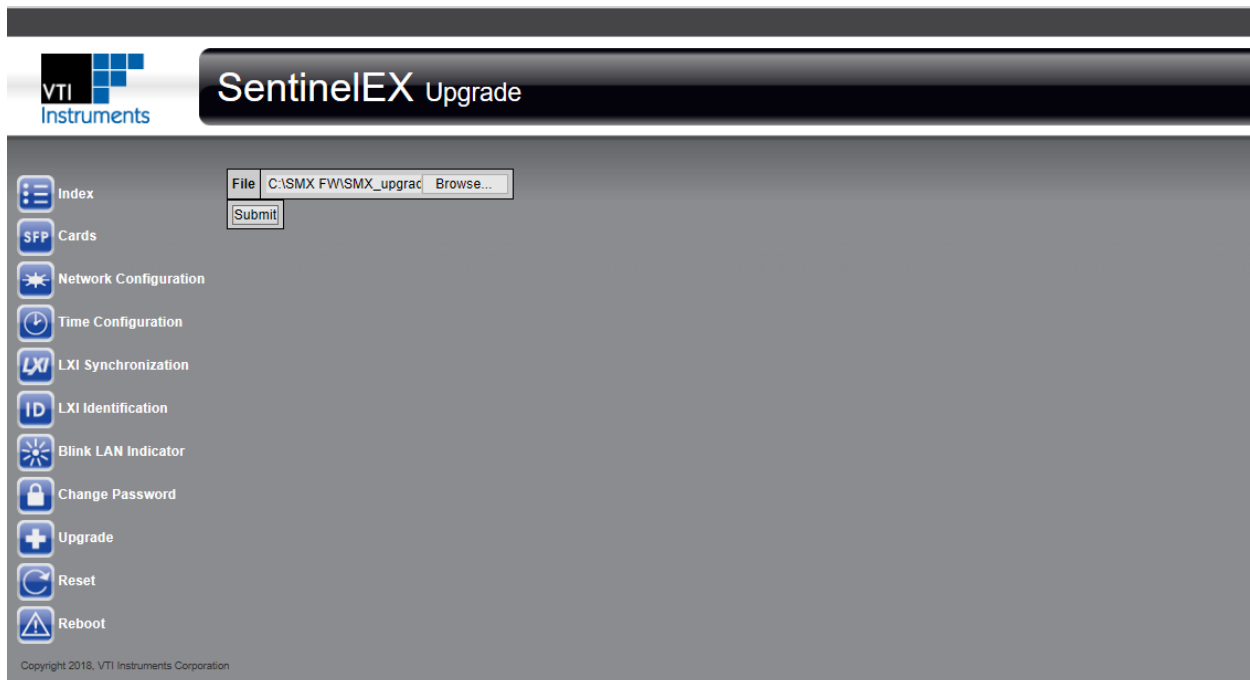

FIGURE 1-5: CLICKING SUBMIT TO START UPGRADE

This will upgrade the switch firmware on all the Switch cards plugged in. After upgrade is completed, power cycle the chassis.

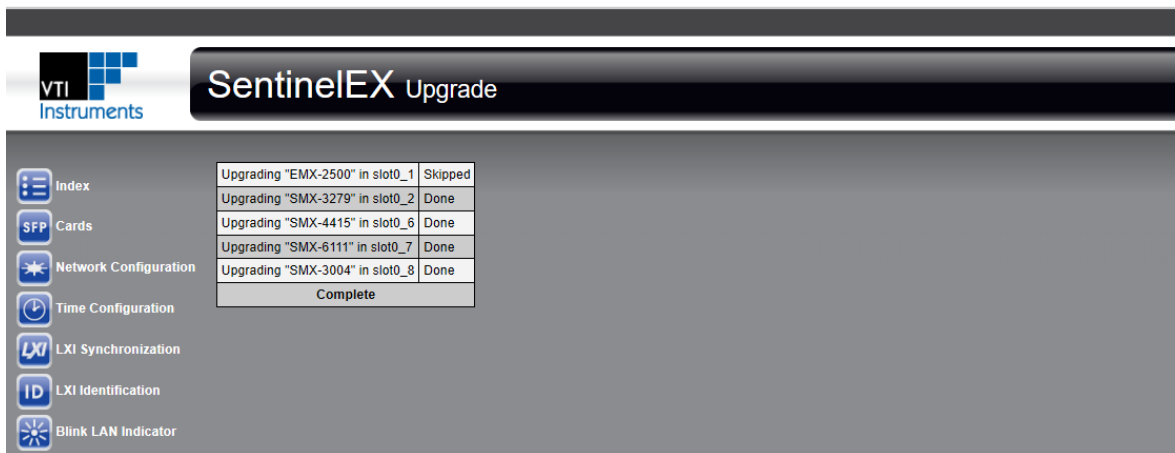

FIGURE 1-6: RUNNING UPGRADE

MODULE SHIELDING/GROUNDING

Most SMX modules incorporate an integral shield into the design of the PCB that attenuates noise and crosstalk between adjacent channels/modules. To properly utilize this feature, tie the appropriate front panel connector pins to the mating cable's common shield and/or ground. If this feature is present on a module, the pins are identified in the module appendix in the *Connector Pins and Signals* table and the signal is noted as "SHIELD".

Leaving the SHIELD pins unconnected may have detrimental effects on signal crosstalk and isolation. If no cable shield connection is available, chassis ground may be used to attach the SHIELD pins.

Many plug-in modules also incorporate ground pins, labeled "GND_C" or simply "GND". These pins tie the module to chassis ground. Note that the SHIELD pins are not tied to ground and have no electrical connections.

APPLICATION ENVIRONMENTS

The SMX switching platform supports a wide variety of application environments. The switches can be manually controlled through the embedded, web-based soft front panel or programmatically on a Windows-based PC through the provided IVI VTEXSwitch driver controlled on most platforms through the IVI driver. LabVIEW driver support is also available. The SMX also allows for integration into NI's Switch Executive for high-level configuration and control.

CONNECTING TO EMBEDDED SLOT-0 PXIE CONTROLLER

Before connecting to the Digitizer card from your Windows system, make sure you have downloaded and installed the "*PCIe System Software Package*" on your Windows system. Refer to the link below to download the file.

<https://www.powerandtest.com/ate-data-acq/platforms/pxi-express/mainframes-and-controllers/emx2401>

Details of Sentinel series cards can also be observed under device manager. See picture below

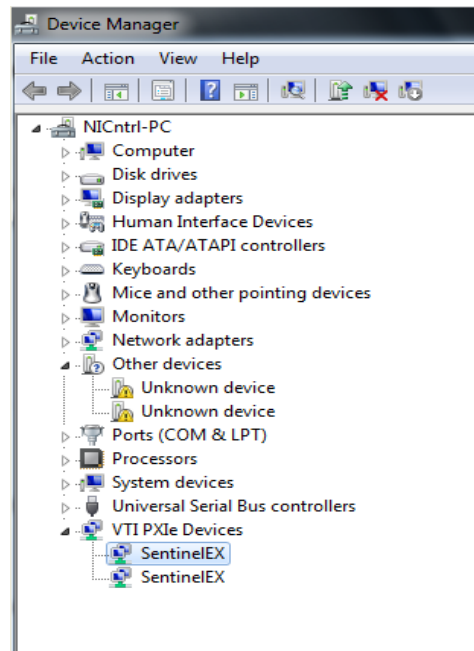



FIGURE 1-7: SENTINEL CARDS DETAILS IN DEVICE MANAGER

To connect to a switch card from the client source code, first declare its driver variable.

```
IVTEXSwitchPtr spDriver(_uuidof(VTEXSwitch));
```

Call the drivers Initialize function, which will open a connection to the card. This function expects 4 arguments. First is the connection string which is a combination of IP address and slot no in which the card is plugged in. The name of this Resource string can be taken from the Resource column in SFP page for that card. See the box in Red in the picture below. Here the Switch card is plugged in slot no 4 of system with IP 127.0.0.1 So our Resource string is **“TCPIP::127.0.0.1::slot1_4::INSTR”** (Note: When an embedded slot-0 PXIe controller is used, the IP address by default becomes 127.0.0.1). The 2nd and 3rd arguments are Query and Rest values which are Boolean values respectively. The last is an optional string in which we can set our own values if we don't want to use the default values for certain parameters like timeout, Query Instrument Status. By default always mention CACHE value as FALSE in this string.



SentinelEX Cards

[Contact](#)
[Support](#)
[VTI Home](#)

 Cards

 Upgrade

 Reset

Device	Model	Revision	Serial	Description	Resource
Slot 1:2	EMX-1434	1.6.7	714968	Tachometer, DIO, Source module	TCPIP::127.0.0.1::slot1_2::INSTR
Slot 1:3	EMX-4350	1.8.5	729458A	4-channel 625kHz IEPE Digitizer	TCPIP::127.0.0.1::slot1_3::INSTR
Slot 1:4	SMX-4410	1.2.4	123456	Switch module	TCPIP::127.0.0.1::slot1_4::INSTR

Copyright 2013, VTI Instruments Corporation

FIGURE 1-8: SFP PAGE AFTER INSTALL / UPGRADE

```
_bstr_t option_string = "Cache=False";
_bstr_t resource = "TCPIP::127.0.0.1::slot1_4::INSTR";

spDriver->Initialize(resource, VARIANT_FALSE, VARIANT_TRUE, option_string);

// The above call opens a connection to the card plugged in the chassis.
// If Initialize call fails, a null value is returned to the driver.
// Below is a sample code.

_bstr_t option_string = "Cache=False";
_bstr_t resource = "TCPIP::127.0.0.1::slot1_4::INSTR";

IVTEXSwitchPtr spDriver(__uuidof(VTEXSwitch));
spDriver->Initialize(resource, VARIANT_FALSE, VARIANT_TRUE, option_string);

// IlviDriverIdentity properties - Initialize required
_bstr_t bstrInstModel = spDriver->Identity->InstrumentModel;
wprintf(L"InstrumentModel: %s\n", bstrInstModel.GetBSTR());

_bstr_t bstrInstFirmwareRevision = spDriver->Identity->InstrumentFirmwareRevision;
wprintf(L"InstrumentFirmwareRevision: %s\n", bstrInstFirmwareRevision.GetBSTR());

_bstr_t bstrInstManufacturer = spDriver->Identity->InstrumentManufacturer;
wprintf(L"InstrumentManufacturer: %s\n\n", bstrInstManufacturer.GetBSTR());

if (spDriver != NULL && spDriver->Initialized)
{
    // Close driver
    spDriver->Close();
}
spDriver = NULL;
```

DIRECT PCIe REGISTER CONTROL INTERFACE FOR SMX CARDS

All SMX Plug-In cards use PCIe Base Address Registers 0 and 2, in 64-bit mode for message-based communication with the SentinelEX web server. Alternatively, Base Address Register 4 can be used to control the card via direct register access over PCIe.

Please refer “82-0147-100_SMX_PcIe_ICD” from “DOCUMENTS AND DOWNLOAD” section of respective SMX- Model from <https://www.powerandtest.com/ate-data-acq/platforms/pxi-express/switching> document for more information.

PXIe PLATFORM

PXI Express is the fastest data acquisition platform currently available with unmatched bandwidths in excess of 1 GB/s and latencies less than 1 μ s. This makes PXI Express-based data acquisition systems ideal for data intensive applications like high-speed digitization, signal-generation, and communication interfaces where high sample rates and channel counts could choke other interfaces. PXI Express provides faster throughput and since it is based on PCI Express, it is more resistant to obsolescence compared to its PXI predecessor.

VTI PXIe ADVANTAGES

Reliability:

VTI is the first choice for mission critical applications or applications where the cost of test is high and failure is not an option. Applications include missile system testing and solid rocket motor testing. This is because our products are recognized in the industry for their reliability and are designed with built-in capabilities to maximize measurement confidence.

Longevity:

Customers expect the test systems to last at least as long as the products they test. This can especially be a challenge in the aerospace and defense industries where products typically last more than a decade. This is why every VTI product is designed to minimize obsolescence risks and guarantee long-term support.

For our PXIe chassis and PXIe subsystems in particular, we ensure that our equipment is resistant to obsolescence by utilizing system-on-chip (SoC) architectures. We don't have to be dependent on the continuing availability of controller chips from other manufacturers.

Precision and Performance:

VTI's strength is in hardware and our products are designed to maximize accuracy, precision, and performance. The types of industries that utilize our products reflect this. Our data acquisition systems are used in applications such as jet engine testing, aircraft structural testing, and satellite testing.

Hybrid Test System Support:

Test systems often leverage the strengths of multiple instrumentation platforms in order to arrive at the best performing or most cost-effective solution. VTI's PXI Express products are uniquely designed to simplify integration with other platforms

SECTION 2

SWITCHING OVERVIEW

GENERAL PURPOSE SWITCHING

When selecting switch cards for a test system, the following should be taken into consideration:

- Power Specifications
- Minimum Contact Rating
- Switching Time
- Bandwidth

The relay must be able to accommodate both the voltage, current, and total power that will be switched and all of these specifications should be checked before making a selection. The minimum contact rating and switching time specifications are important in systems where relays will be opened and closed many times throughout the test. The faster the switch performs, the faster the test will finish. The bandwidth specification indicates the frequencies the switch is able to switch. Interchannel isolation and crosstalk are also affected by the frequency of the signals being switched.

POWER SWITCHING

The SMX-2002 high-power switch cards provide high-power switching in a small form factor. The SMX-2002 are the only switch modules in their class with the ability to switch up to 16 A. As such, the high-power cards are an ideal solution for applications such as: ac line power switching, switching of dc or power supplies, controlling or driving relays for industrial machines (robotics, numerical control machines), automotive engine control, and solenoid switching. These switch cards also include a front panel interrupt line which will open all relays in the module to provide safety. They can also be used in the setup phase to switch power to and from a DUT.

MATRIX/MULTIPLEXER SWITCHING

Matrix and multiplexer cards give the user the ability to combine multiple modules in the same chassis to create larger switching systems: For matrix cards, multiple cards can be combined by connecting either rows or columns of the relay together with external wiring.

To improve bandwidth specifications, it is important to utilize the stub breaking relays that are incorporated into most matrix and multiplexer cards. These relays typically separate banks of relays from each other. By keeping these relays open, the length a signal must travel, and the amount of resistance it will encounter, can be reduced, increasing the path's bandwidth. Examples of these relays are shown in Figure 2-1.

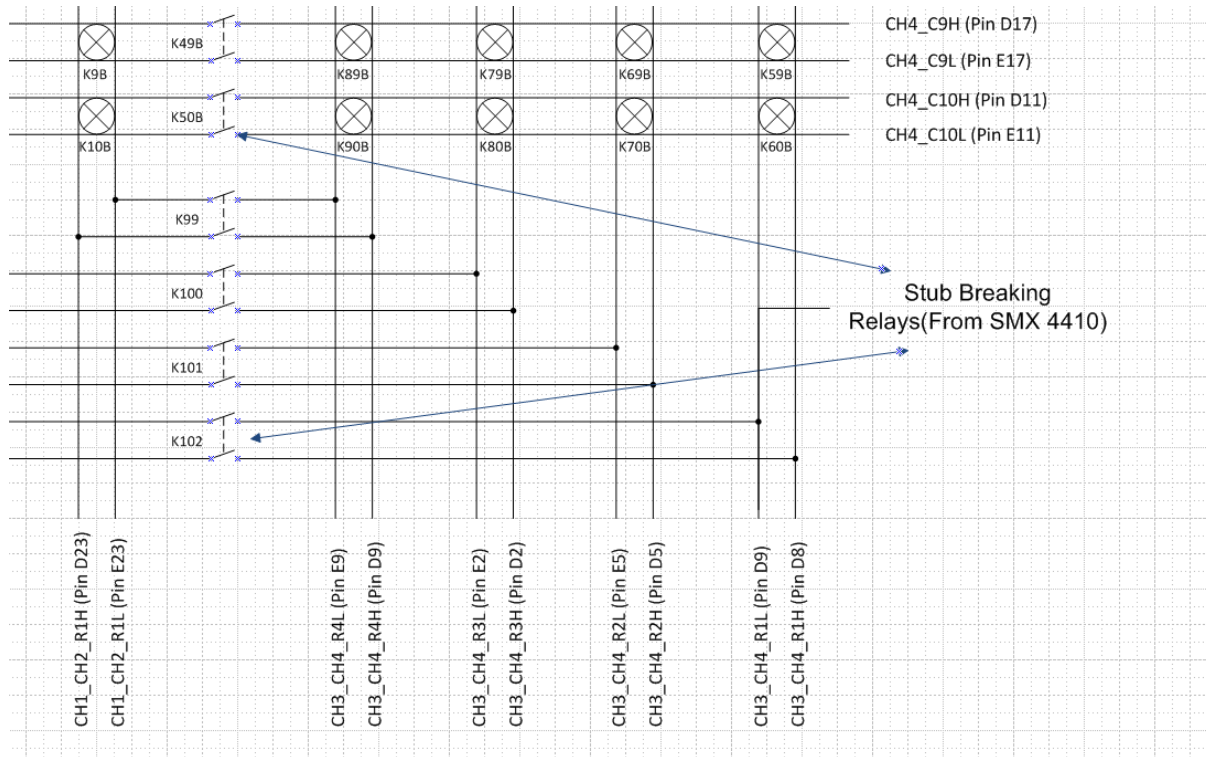

FIGURE 2-1: STUB BREAKING RELAYS

SMX MODULES

The following table lists VTISMX modules along with configuration and corresponding 70-level Part Numbers

NOTE SMX-3xxxDS models support DISCHARGE (DS) relays
SMX-61xx models without SMB in model name are SMX-61xx models with PkZ connector

Model	P/N	Configuration
Multiplexers		
SMX-3001	70-0409-220R	(8) 1x8, 2-wire multiplexer, fully configurable
SMX-3002	70-0409-221R	(8) 1x8, 2-wire multiplexer, fixed
SMX-3003	70-0409-222R	(4) 1x16, 2-wire multiplexer, fixed
SMX-3004	70-0409-223R	(2) 1x32, 2-wire multiplexer, fixed
SMX-3005	70-0409-224R	(1) 1x64, 2-wire multiplexer, fixed
SMX-3006	70-0409-128R	(1) 1x128, 1-wire multiplexer, fixed
SMX-3007	70-0409-129R	(2) 1x64, 1-wire multiplexer, fixed
SMX-3276	70-0409-009R	(2) 1x38, 2-wire multiplexer, fully configurable
SMX-3277	70-0409-103R	(2) 1x76, 1-wire multiplexer, fixed
SMX-3278	70-0409-104R	(1) 1x76, 1-wire multiplexer, fixed
SMX-3279	70-0409-105R	(1) 1x76, 2-wire multiplexer, fixed
SMX-3280	70-0409-225R	(1) 1x152, 1-wire multiplexer, fixed
SMX-3001DS	70-0409-123R	(8) 1x8, 2-wire multiplexer, fully configurable
SMX-3002DS	70-0409-124R	(8) 1x8, 2-wire multiplexer, fixed
SMX-3003DS	70-0409-125R	(4) 1x16, 2-wire multiplexer, fixed
SMX-3004DS	70-0409-126R	(2) 1x32, 2-wire multiplexer, fixed
SMX-3005DS	70-0409-127R	(1) 1x64, 2-wire multiplexer, fixed
SMX-3276DS	70-0409-136R	(2) 1x38, 2-wire multiplexer, fully configurable
SMX-3277DS	70-0409-139R	(2) 1x76, 1-wire multiplexer, fixed
SMX-3278DS	70-0409-137R	(1) 1x76, 1-wire multiplexer, fixed
SMX-3279DS	70-0409-138R	(1) 1x76, 2-wire multiplexer, fixed
SMX-3280DS	70-0409-226R	(1) 1x152, 1-wire multiplexer, fixed
Matrix		
SMX-4410	70-0409-108R	(4) 4x10, 2-wire, fully configurable
SMX-4411	70-0409-200R	(4) 4x10 2-wire Matrices
SMX-4412	70-0409-201R	(2) 4x20 2-wire Matrices
SMX-4413	70-0409-202R	(1) 4x40 2-wire Matrices
SMX-4414	70-0409-203R	(2) 8x10 2-wire Matrices
SMX-4415	70-0409-204R	(1) 8x20 2-wire Matrices
General Purpose		
SMX-2001-10	70-0409-581R	(10) SPST

Model	P/N	Configuration
SMX-2001-12	70-0409-583R	(12) SPST
SMX-2001-16	70-0409-584R	(16) SPST
SMX-2002-10	70-0409-570R	(10) SPDT
SMX-2002-12	70-0409-582R	(12) SPDT
SMX-5001	70-0409-110R	(80) SPST/Form A
SMX-5002	70-0409-118R	(50) SPDT/Form C
SMX-5004	70-0409-580R	(30) SPDT/Form C
RF Multiplexer - 50 Ohm		
SMX-6101	70-0409-140R	(10) 1X4 COAX MUX
SMX-6101 SMB	70-0409-150R	(10) 1X4 COAX MUX
SMX-6111	70-0409-144R	(5) 1X4 COAX MUX
SMX-6111 SMB	70-0409-154R	(5) 1X4 COAX MUX
SMX-6106	70-0409-143R	(2) 1X16 COAX MUX
SMX-6106 SMB	70-0409-153R	(2) 1X16 COAX MUX
SMX-6116	70-0409-146R	(1) 1X16 COAX MUX
SMX-6116 SMB	70-0409-156R	(1) 1X16 COAX MUX
SMX-6105	70-0409-142R	(4) 1X8 COAX MUX
SMX-6105 SMB	70-0409-152R	(4) 1X8 COAX MUX
SMX-6115	70-0409-145R	(2) 1X8 COAX MUX
SMX-6115 SMB	70-0409-155R	(2) 1X8 COAX MUX
SMX-6103	70-0409-141R	(1) 1X32 COAX MUX
SMX-6103 SMB	70-0409-151R	(1) 1X32 COAX MUX
RF Matrix - 50 Ohm		
SMX-6144	70-0409-147R	(1) 4X4 COAX MATRIX
SMX-6144 SMB	70-0409-157R	(1) 4X4 COAX MATRIX
Microwave		
SMX-7121-18	70-0409-509R	SINGLE SLOT WITH (1) SPDT 18GHZ MW SWITCH
SMX-7122-18	70-0409-510R	SINGLE SLOT WITH (2) SPDT 18GHZ MW SWITCH
SMX-7223-18	70-0409-533R	DUAL SLOT WITH (3) SPDT 18GHZ MW SWITCH
SMX-7224-18	70-0409-534R	DUAL SLOT WITH (4) SPDT 18GHZ MW SWITCH
SMX-7121-26	70-0409-517R	SINGLE SLOT WITH (1) SPDT 26.5GHZ MW SWITCH
SMX-7122-26	70-0409-518R	SINGLE SLOT WITH (2) SPDT 26.5GHZ MW SWITCH
SMX-7223-26	70-0409-535R	DUAL SLOT WITH (3) SPDT 26.5GHZ MW SWITCH
SMX-7224-26	70-0409-536R	DUAL SLOT WITH (4) SPDT 26.5GHZ MW SWITCH
SMX-7121-40	70-0409-525R	SINGLE SLOT WITH (1) SPDT 40GHZ MW SWITCH
SMX-7122-40	70-0409-526R	SINGLE SLOT WITH (2) SPDT 40GHZ MW SWITCH

Model	P/N	Configuration
SMX-7223-40	70-0409-537R	DUAL SLOT WITH (3) SPDT 40GHZ MW SWITCH
SMX-7224-40	70-0409-538R	DUAL SLOT WITH (4) SPDT 40GHZ MW SWITCH
SMX-7121-50	70-0409-539R	SINGLE SLOT WITH (1) SPDT 50GHZ MW SWITCH
SMX-7122-50	70-0409-540R	SINGLE SLOT WITH (2) SPDT 50GHZ MW SWITCH
SMX-7223-50	70-0409-541R	DUAL SLOT WITH (3) SPDT 50GHZ MW SWITCH
SMX-7224-50	70-0409-542R	DUAL SLOT WITH (4) SPDT 50GHZ MW SWITCH
SMX-7121-67	70-0409-543R	SINGLE SLOT WITH (1) SPDT 67GHZ MW SWITCH
SMX-7122-67	70-0409-544R	SINGLE SLOT WITH (2) SPDT 67GHZ MW SWITCH
SMX-7223-67	70-0409-545R	DUAL SLOT WITH (3) SPDT 67GHZ MW SWITCH
SMX-7224-67	70-0409-546R	DUAL SLOT WITH (4) SPDT 67GHZ MW SWITCH
SMX-7241-06	70-0409-503R	DUAL SLOT WITH (1) SP4T 6GHZ MW SWITCH
SMX-7242-06	70-0409-504R	DUAL SLOT WITH (2) SP4T 6GHZ MW SWITCH
SMX-7243-06	70-0409-505R	DUAL SLOT WITH (3) SP4T 6GHZ MW SWITCH
SMX-7241-26	70-0409-519R	DUAL SLOT WITH (1) SP4T 26.5GHZ MW SWITCH
SMX-7242-26	70-0409-520R	DUAL SLOT WITH (2) SP4T 26.5GHZ MW SWITCH
SMX-7243-26	70-0409-521R	DUAL SLOT WITH (3) SP4T 26.5GHZ MW SWITCH
SMX-7241-40	70-0409-527R	DUAL SLOT WITH (1) SP4T 40GHZ MW SWITCH
SMX-7242-40	70-0409-528R	DUAL SLOT WITH (2) SP4T 40GHZ MW SWITCH
SMX-7243-40	70-0409-529R	DUAL SLOT WITH (3) SP4T 40GHZ MW SWITCH
SMX-7261-06	70-0409-506R	DUAL SLOT WITH (1) SP6T 6GHZ MW SWITCH
SMX-7262-06	70-0409-507R	DUAL SLOT WITH (2) SP6T 6GHZ MW SWITCH
SMX-7263-06	70-0409-508R	DUAL SLOT WITH (3) SP6T 6GHZ MW SWITCH
SMX-7261-26	70-0409-522R	DUAL SLOT WITH (1) SP6T 26.5GHZ MW SWITCH
SMX-7262-26	70-0409-523R	DUAL SLOT WITH (2) SP6T 26.5GHZ MW SWITCH
SMX-7263-26	70-0409-524R	DUAL SLOT WITH (3) SP6T 26.5GHZ MW SWITCH
SMX-7261-40	70-0409-530R	DUAL SLOT WITH (1) SP6T 40GHZ MW SWITCH
SMX-7262-40	70-0409-531R	DUAL SLOT WITH (2) SP6T 40GHZ MW SWITCH
SMX-7263-40	70-0409-532R	DUAL SLOT WITH (3) SP6T 40GHZ MW SWITCH
SMX-72T1-26	70-0409-551R	DUAL SLOT WITH (1) 26.5GHZ TRANSFER SWITCH
SMX-72T2-26	70-0409-552R	DUAL SLOT WITH (2) 26.5GHZ TRANSFER SWITCH
SMX-72T1-40	70-0409-554R	DUAL SLOT WITH (1) 40GHZ TRANSFER SWITCH
SMX-72T2-40	70-0409-555R	DUAL SLOT WITH (2) 40GHZ TRANSFER SWITCH
SMX-72T1-50	70-0409-557R	DUAL SLOT WITH (1) 50GHZ TRANSFER SWITCH
SMX-72T2-50	70-0409-558R	DUAL SLOT WITH (2) 50GHZ TRANSFER SWITCH

TABLE 2-1: SMX-PLUG IN MODELS

SECTION 3

SMX-2001-10 SWITCH MODULE

10-CHANNEL 16 A FORM A (SPST) SWITCH

The SMX-2001-10 is a PXIe SPST switch module capable of switching up to 16 A. As a high current switch module, possible applications include AC line power switching; switching AC or DC power supplies; controlling/driving relays for industrial machines, such as robotics and numerical control machines; automotive engine control; and solenoid switching.

The digital input lines on the SMX-2001-10 front panel allow the user to isolate the UUT and/or interface by forcing all relays to their normally open state when a fault condition occurs. This approach instantly removes all power to the switches and the UUT/interface is functionally disconnected from the switch module.

All relays are independently controlled. The SMX-2001-10 can be programmatically controlled using IviSwitch-complaint calls. Both path-level programming and individual relay control are available. 3-1 provides the Front Panel Connector detail followed by the Pin outs. Logical diagram of Switch module is represented in 3-2. This information can be used for individual relay control through the driver.

CONNECTOR PINS AND SIGNALS

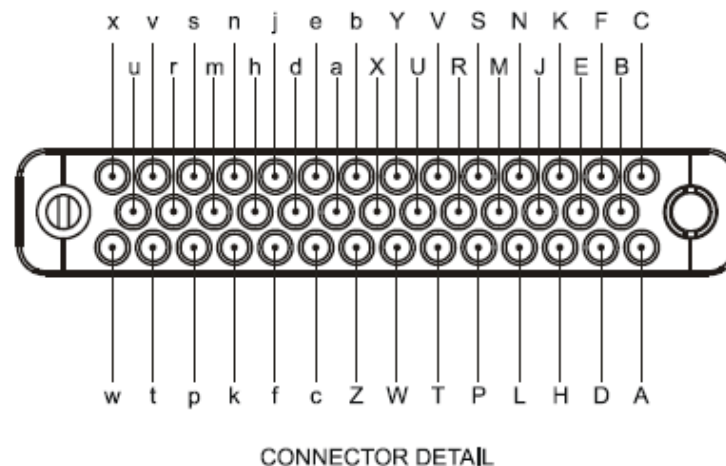

FIGURE 3-1: SMX-2001-10 FRONT PANEL (FRONT VIEW)

NOTE Pin x is connected to a shield layer located directly under the relays and connecting wires. Optimum performance is obtained when Pin x is tied to system or chassis ground and the front panel mounting screws are secured to the chassis frame

POWER REQUIREMENTS

5Vaux	3P3V	12VP
0	0.726 W	6.5W

10 CH SPST					
PIN	SIGNAL	PIN	SIGNAL	PIN	SIGNAL
A	CH_1NO	B	CH_1COM	C	unused
D	CH_2NO	E	CH_2COM	F	unused
H	CH_3NO	J	CH_3COM	K	unused
L	CH_4NO	M	CH_4COM	N	unused
P	CH_5NO	R	CH_5COM	S	unused
T	CH_6NO	U	CH_6COM	V	unused
W	CH_7NO	X	CH_7COM	Y	unused
Z	CH_8NO	a	CH_8COM	b	unused
c	CH_9NO	d	CH_9COM	e	unused
f	CH_10NO	h	CH_10COM	j	unused
k	unused	m	unused	n	unused
p	unused	r	unused	s	unused
t	FP_OPEN	u	unused	v	unused
w	FP_GND	x	CUS_SHIELD		

TABLE 3-1: CONNECTOR PINS & SIGNAL ASSIGNMENTS

On the SMX-2001-10 Front Panel there are two pins for access to the Front Panel Open signal of the module. These are Front Panel Open signal pin (FP_OPEN) and Ground reference pin (FP_GND). The purpose of the Front Panel Open signal is to allow user access to a configurable interlock feature that will reset all of the SMX-2001-10 relays. By default, FP_OPEN feature will be disabled. Through driver API user can enable this feature. FP_OPEN can be configured to either LEVEL or EDGE, once asserted FP_OPEN signal status will be latched which can be cleared using a reset command.

LOGICAL DIAGRAM

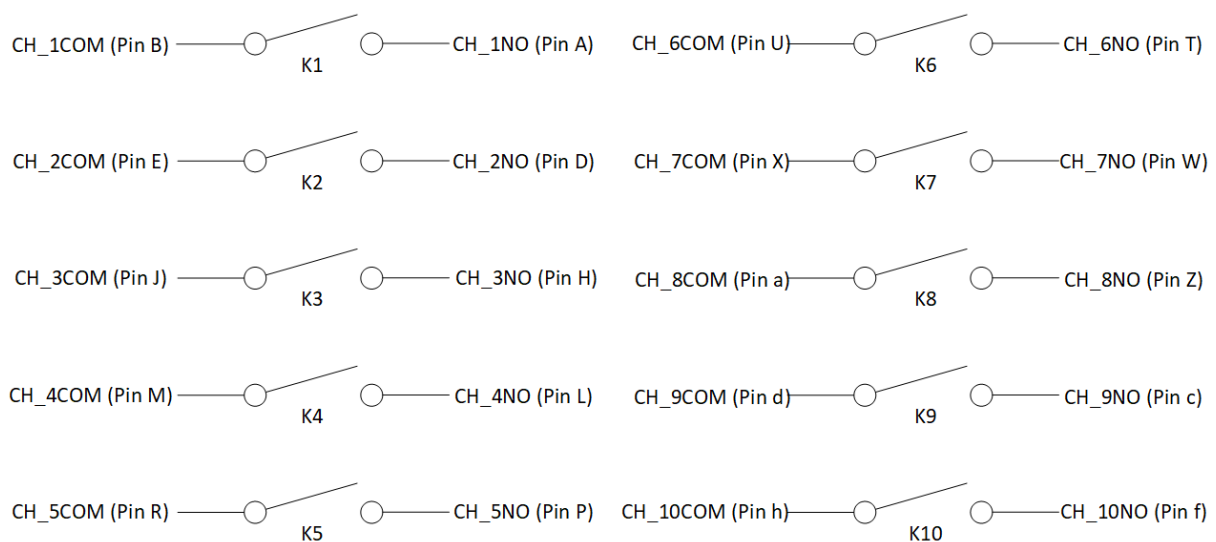

Figure 3-2: SMX-2001-10 Logical Diagram

SMX-2001-10 SPECIFICATIONS

GENERAL SPECIFICATIONS	
CHANNEL COUNT	10 SPST
RELAY TYPE	Electromechanical, Power Relay
MAXIMUM SWITCHING VOLTAGE	300 V dc*, 250 V ac
MAXIMUM SWITCHING CURRENT	16 A
MAXIMUM SWITCHING POWER	448 W*, 4000 VA Breaking capacity
RATED SWITCH OPERATIONS	
Mechanical	>30 x 10 ⁶
Electrical	>1 x 10 ⁴
SWITCHING TIME	< 14 ms
PATH RESISTANCE	<100 mΩ
MAXIMUM THERMAL OFFSET PER CHANNEL (HI-LO)	< 30 μV
CAPACITANCE	
Open channel	<61 pF
Channel-mainframe	<76 pF
BANDWIDTH (-3 dB)	45 MHz (best)
INSERTION LOSS (TYPICAL)	
100 kHz	< 0.41 dB
1 MHz	< 0.45 dB
10 MHz	< 0.6 dB
CROSSTALK (TYPICAL)	
100 kHz	< -63 dB
1 MHz	< -53 dB
ISOLATION (TYPICAL)	
100 kHz	< -72 dB
1 MHz	< -52 dB

* For DC Voltage and Current, refer Figure 3-3.

FOR MATING CONNECTOR, CRIMP PINS, AND OTHER ACCESSORIES, PLEASE REFER TO APPENDIX B

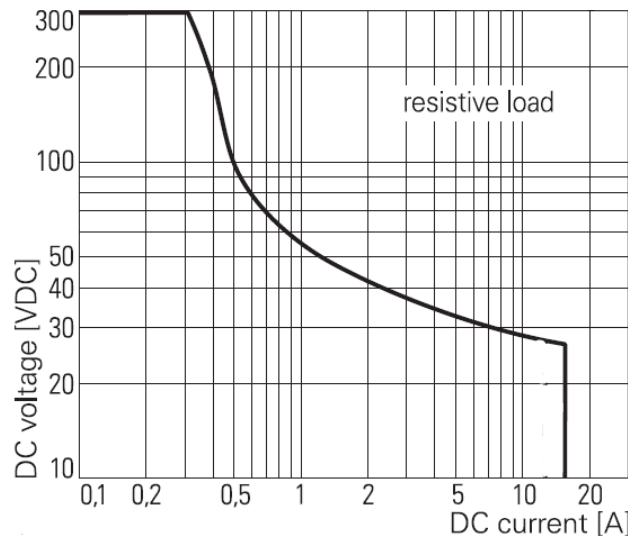

Figure 3-3: Max. DC load breaking capacity

SMX-2001-12 SWITCH MODULE

12-CHANNEL 16 A FORM A (SPST) SWITCH

The SMX-2001-12 is a PXIe SPST switch module capable of switching up to 16 A. As a high current switch module, possible applications include AC line power switching; switching AC or DC power supplies; controlling/driving relays for industrial machines, such as robotics and numerical control machines; automotive engine control; and solenoid switching.

The digital input lines on the SMX-2001-12 front panel allow the user to isolate the UUT and/or interface by forcing all relays to their normally open state when a fault condition occurs. This approach instantly removes all power to the switches and the UUT/interface is functionally disconnected from the switch module.

All relays are independently controlled. The SMX-2001-12 can be programmatically controlled using IviSwitch-compliant calls. Both path-level programming and individual relay control are available. 3-4 provides the Front Panel Connector detail followed by the Pin outs. Logical diagram of Switch module is represented in **Error! Reference source not found.**. This information can be used for individual relay control through the driver.

CONNECTOR PINS AND SIGNALS

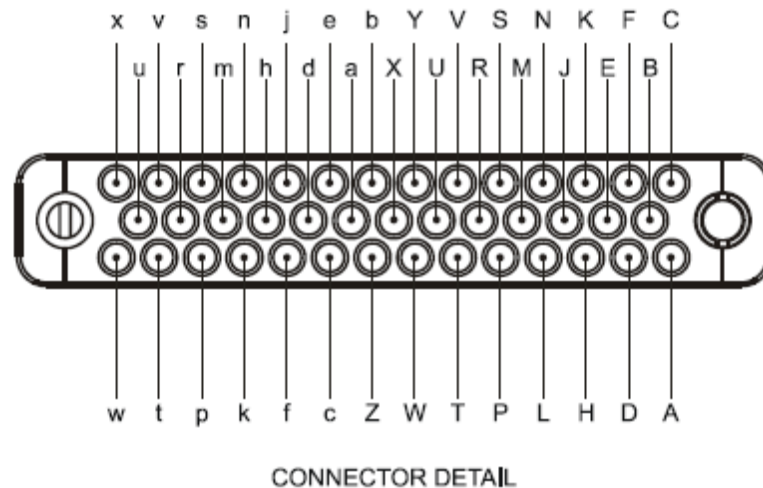

FIGURE 3-4: SMX-2001-12 FRONT PANEL (FRONT VIEW)

NOTE Pin x is connected to a shield layer located directly under the relays and connecting wires. Optimum performance is obtained when Pin x is tied to system or chassis ground and the front panel mounting screws are secured to the chassis frame.

POWER REQUIREMENTS

5Vaux	3P3V	12VP
0	0.726 W	6.5W

12 CH SPST					
PIN	SIGNAL	PIN	SIGNAL	PIN	SIGNAL
A	CH_1NO	B	CH_1COM	C	unused
D	CH_2NO	E	CH_2COM	F	unused
H	CH_3NO	J	CH_3COM	K	unused
L	CH_4NO	M	CH_4COM	N	unused
P	CH_5NO	R	CH_5COM	S	unused
T	CH_6NO	U	CH_6COM	V	unused
W	CH_7NO	X	CH_7COM	Y	unused
Z	CH_8NO	a	CH_8COM	b	unused
c	CH_9NO	d	CH_9COM	e	unused
f	CH_10NO	h	CH_10COM	j	unused
k	CH_11NO	m	CH_11COM	n	unused
p	CH_12NO	r	CH_12COM	s	unused
t	FP_OPEN	u	unused	v	unused
w	FP_GND	x	CUS_SHIELD		

TABLE 3-2: CONNECTOR PINS & SIGNAL ASSIGNMENTS

On the SMX-2001-12 Front Panel there are two pins for access to the Front Panel Open signal of the module. These are Front Panel Open signal pin (FP_OPEN) and Ground reference pin (FP_GND). The purpose of the Front Panel Open signal is to allow user access to a configurable interlock feature that will reset all of the SMX-2001-12 relays. By default, FP_OPEN feature will be disabled. Through driver API user can enable this feature. FP_OPEN can be configured to either LEVEL or EDGE, once asserted FP_OPEN signal status will be latched which can be cleared using a reset command.

LOGICAL DIAGRAM

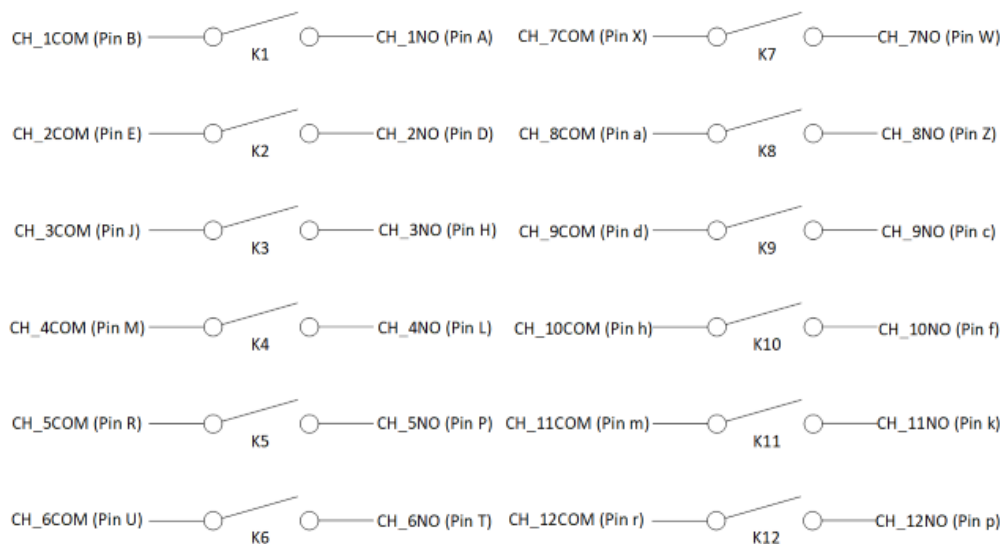

FIGURE 3-5: SMX-2001-12 LOGICAL DIAGRAM

SMX-2001-12 SPECIFICATIONS

GENERAL SPECIFICATIONS	
CHANNEL COUNT	12 SPST
RELAY TYPE	Electromechanical, Power Relay
MAXIMUM SWITCHING VOLTAGE	300 V dc*, 250 V ac
MAXIMUM SWITCHING CURRENT	16 A
MAXIMUM SWITCHING POWER	448 W*, 4000 VA Breaking capacity
RATED SWITCH OPERATIONS	
Mechanical	>30 x 10 ⁶
Electrical	>1 x 10 ⁴
SWITCHING TIME	< 14 ms
PATH RESISTANCE	<100 mΩ
MAXIMUM THERMAL OFFSET PER CHANNEL (HI-LO)	< 30 μV
CAPACITANCE	
Open channel	<61 pF
Channel-mainframe	<76 pF
BANDWIDTH (-3 dB)	45 MHz (best)
INSERTION LOSS (TYPICAL)	
100 kHz	< 0.41 dB
1 MHz	< 0.45 dB
10 MHz	< 0.6 dB
CROSSTALK (TYPICAL)	
100 kHz	< -63 dB
1 MHz	< -53 dB
ISOLATION (TYPICAL)	
100 kHz	< -72 dB
1 MHz	< -52 dB

* For DC Voltage and Current, refer Figure 3-6.

FOR MATING CONNECTOR, CRIMP PINS, AND OTHER ACCESSORIES, PLEASE REFER TO APPENDIX B

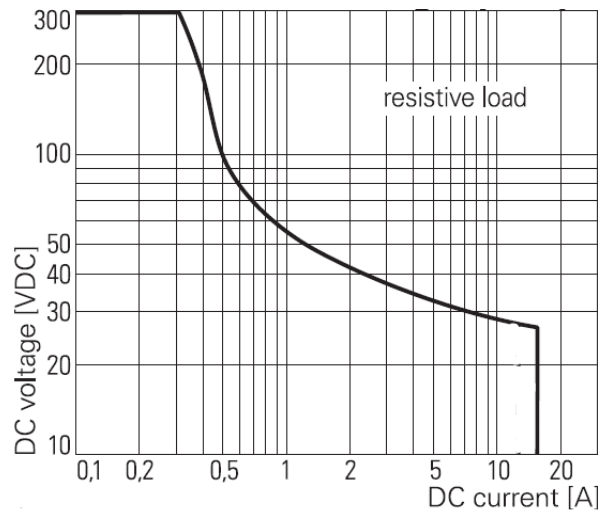

Figure 3-6: Max. DC load breaking capacity

SMX-2001-16 SWITCH MODULE

16-CHANNEL 16 A FORM A (SPST) SWITCH

The SMX-2001-16 is a PXIe SPST switch module capable of switching up to 16 A. As a high current switch module, possible applications include AC line power switching; switching AC or DC power supplies; controlling/driving relays for industrial machines, such as robotics and numerical control machines; automotive engine control; and solenoid switching.

The digital input lines on the SMX-2001-16 front panel allow the user to isolate the UUT and/or interface by forcing all relays to their normally open state when a fault condition occurs. This approach instantly removes all power to the switches and the UUT/interface is functionally disconnected from the switch module.

All relays are independently controlled. The SMX-2001-16 can be programmatically controlled using IviSwitch-compliant calls. Both path-level programming and individual relay control are available. **Error! Reference source not found.** provides the Front Panel Connector detail followed by the Pin outs. Logical diagram of Switch module is represented in 3-8 This information can be used for individual relay control through the driver.

CONNECTOR PINS AND SIGNALS

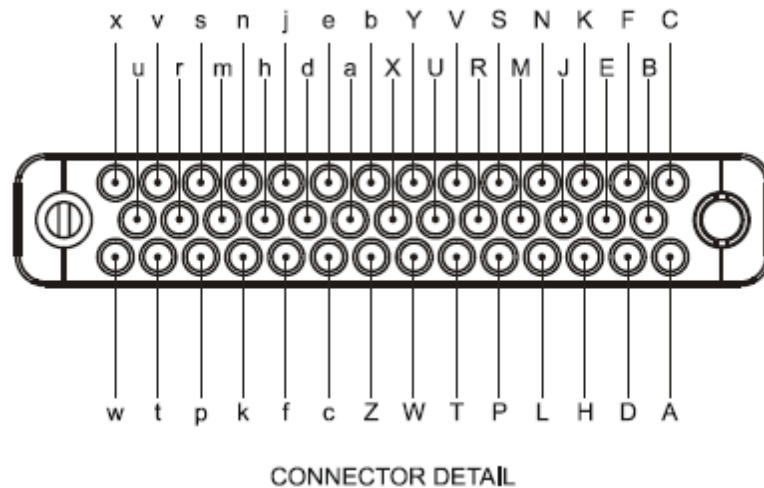

FIGURE 3-7: SMX-2001-16 FRONT PANEL (FRONT VIEW)

NOTE Pin x is connected to a shield layer located directly under the relays and connecting wires. Optimum performance is obtained when Pin x is tied to system or chassis ground and the front panel mounting screws are secured to the chassis frame.

POWER REQUIREMENTS

5Vaux	3P3V	12VP
0	0.726 W	6.5W

16 CH SPST					
PIN	SIGNAL	PIN	SIGNAL	PIN	SIGNAL
A	CH_1NO	B	CH_1COM	C	CH_13NO
D	CH_2NO	E	CH_2COM	F	CH_13COM
H	CH_3NO	J	CH_3COM	K	CH_14NO
L	CH_4NO	M	CH_4COM	N	CH_14COM
P	CH_5NO	R	CH_5COM	S	CH_15NO
T	CH_6NO	U	CH_6COM	V	CH_15COM
W	CH_7NO	X	CH_7COM	Y	CH_16NO
Z	CH_8NO	a	CH_8COM	b	CH_16COM
c	CH_9NO	d	CH_9COM	e	unused
f	CH_10NO	h	CH_10COM	j	unused
k	CH_11NO	m	CH_11COM	n	unused
p	CH_12NO	r	CH_12COM	s	unused
t	FP_OPEN	u	unused	v	unused
w	FP_GND	x	CUS_SHIELD		

TABLE 3-3: CONNECTOR PINS & SIGNAL ASSIGNMENTS

On the SMX-2001-16 Front Panel there are two pins for access to the Front Panel Open signal of the module. These are Front Panel Open signal pin (FP_OPEN) and Ground reference pin (FP_GND). The purpose of the Front Panel Open signal is to allow user access to a configurable interlock feature that will reset all of the SMX-2001-16 relays. By default, FP_OPEN feature will be disabled. Through driver API user can enable this feature. FP_OPEN can be configured to either LEVEL or EDGE, once asserted FP_OPEN signal status will be latched which can be cleared using a reset command.

LOGICAL DIAGRAM

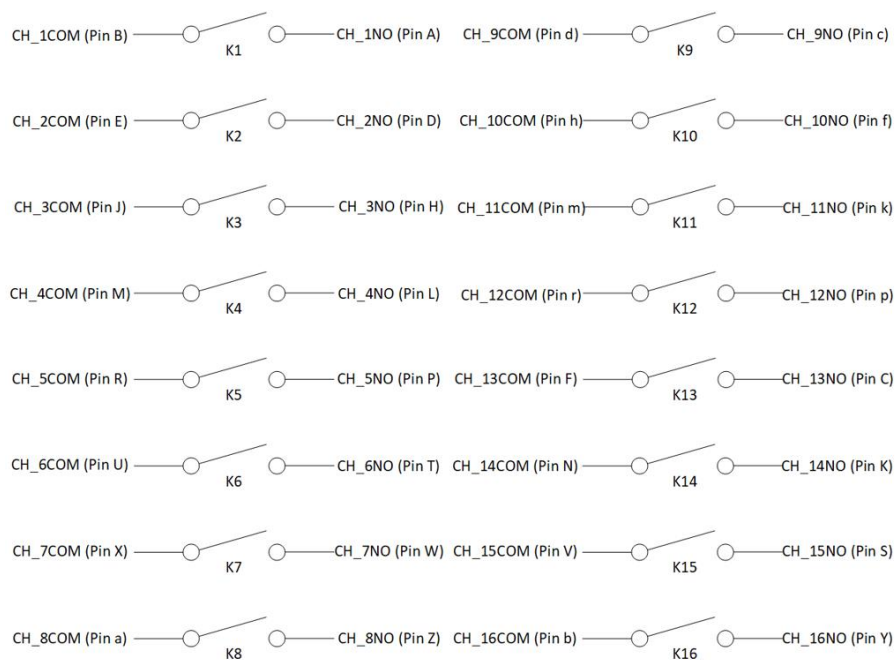

FIGURE 3-8: SMX-2001-16 LOGICAL DIAGRAM

SMX-2001-16 SPECIFICATIONS

GENERAL SPECIFICATIONS	
CHANNEL COUNT	16 SPST
RELAY TYPE	Electromechanical, Power Relay
MAXIMUM SWITCHING VOLTAGE	300 V dc*, 250 V ac
MAXIMUM SWITCHING CURRENT	16 A
MAXIMUM SWITCHING POWER	448 W*, 4000 VA Breaking capacity
RATED SWITCH OPERATIONS	
Mechanical	>30 x 10 ⁶
Electrical	>1 x 10 ⁴
SWITCHING TIME	< 14 ms
PATH RESISTANCE	<100 mΩ
MAXIMUM THERMAL OFFSET PER CHANNEL (HI-LO)	< 30 μV
CAPACITANCE	
Open channel	<61 pF
Channel-mainframe	<76 pF
BANDWIDTH (-3 dB)	45 MHz (best)
INSERTION LOSS (TYPICAL)	
100 kHz	< 0.41 dB
1 MHz	< 0.45 dB
10 MHz	< 0.6 dB
CROSSTALK (TYPICAL)	
100 kHz	< -63 dB
1 MHz	< -53 dB
ISOLATION (TYPICAL)	
100 kHz	< -72 dB
1 MHz	< -52 dB

* For DC Voltage and Current, refer Figure 3-9.

FOR MATING CONNECTOR, CRIMP PINS, AND OTHER ACCESSORIES, PLEASE REFER TO *APPENDIX B*

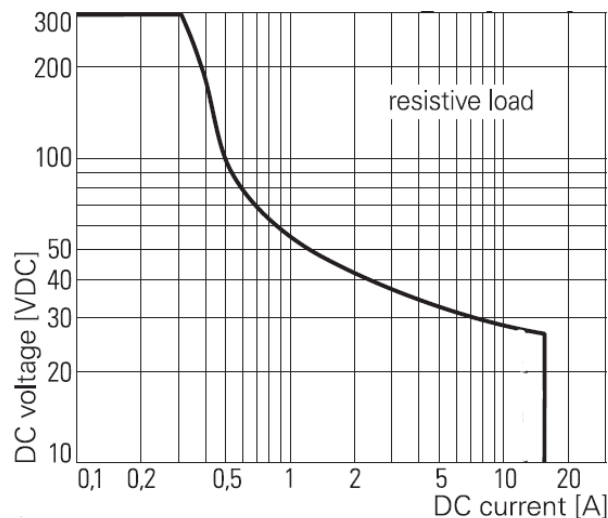

Figure 3-9: Max. DC load breaking capacity

SMX-2002-10 SWITCH MODULE

10-CHANNEL 16 A FORM C (SPDT) SWITCH

The SMX-2002-10 is a PXIe SPDT switch module capable of switching up to 16 A. As a high current switch module, possible applications include AC line power switching; switching AC or DC power supplies; controlling/driving relays for industrial machines, such as robotics and numerical control machines; automotive engine control; and solenoid switching.

The digital input lines on the SMX-2002-10 front panel allow the user to isolate the UUT and/or interface by forcing all relays to their normally open state when a fault condition occurs. This approach instantly removes all power to the switches and the UUT/interface is functionally disconnected from the switch module.

All relays are independently controlled. The SMX-2002-10 can be programmatically controlled using IviSwitch-compliant calls. Both path-level programming and individual relay control are available. **Error! Reference source not found.** provides the Front Panel Connector detail followed by the Pin outs. Logical diagram of Switch module is represented in **Error! Reference source not found.**. This information can be used for individual relay control through the driver.

CONNECTOR PINS AND SIGNALS

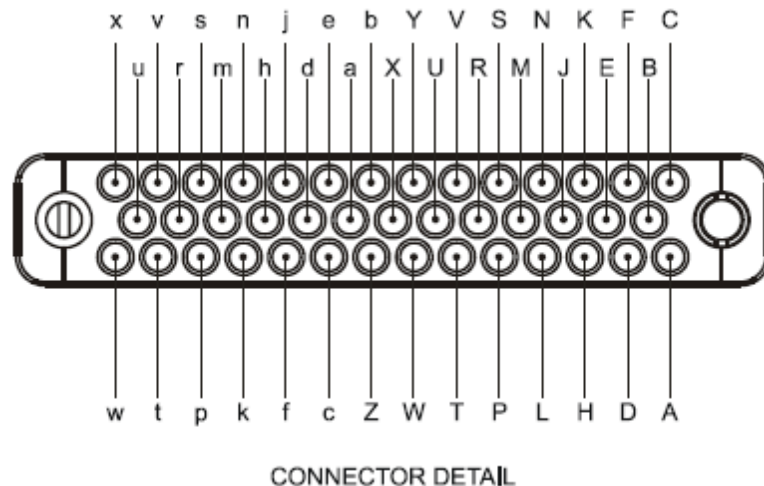

FIGURE 3-10: SMX-2002-10 FRONT PANEL (FRONT VIEW)

NOTE Pin x is connected to a shield layer located directly under the relays and connecting wires. Optimum performance is obtained when Pin x is tied to system or chassis ground and the front panel mounting screws are secured to the chassis frame.

POWER REQUIREMENTS

5Vaux	3P3V	12VP
0	0.726 W	6.5W

10 CH SPDT					
PIN	SIGNAL	PIN	SIGNAL	PIN	SIGNAL
A	CH_1NO	B	CH_1COM	C	CH_1NC
D	CH_2NO	E	CH_2COM	F	CH_2NC
H	CH_3NO	J	CH_3COM	K	CH_3NC
L	CH_4NO	M	CH_4COM	N	CH_4NC
P	CH_5NO	R	CH_5COM	S	CH_5NC
T	CH_6NO	U	CH_6COM	V	CH_6NC
W	CH_7NO	X	CH_7COM	Y	CH_7NC
Z	CH_8NO	a	CH_8COM	b	CH_8NC
c	CH_9NO	d	CH_9COM	e	CH_9NC
f	CH_10NO	h	CH_10COM	j	CH_10NC
k	unused	m	unused	n	unused
p	unused	r	unused	s	unused
t	FP_OPEN	u	unused	v	unused
w	FP_GND	x	CUS_SHIELD		

TABLE 3-4: CONNECTOR PINS & SIGNAL ASSIGNMENTS

On the SMX-2002-10 Front Panel there are two pins for access to the Front Panel Open signal of the module. These are Front Panel Open signal pin (FP_OPEN) and Ground reference pin (FP_GND). The purpose of the Front Panel Open signal is to allow user access to a configurable interlock feature that will reset all of the SMX-2002-10 relays. By default, FP_OPEN feature will be disabled. Through driver API user can enable this feature. FP_OPEN can be configured to either LEVEL or EDGE, once asserted FP_OPEN signal status will be latched which can be cleared using a reset command.

LOGICAL DIAGRAM

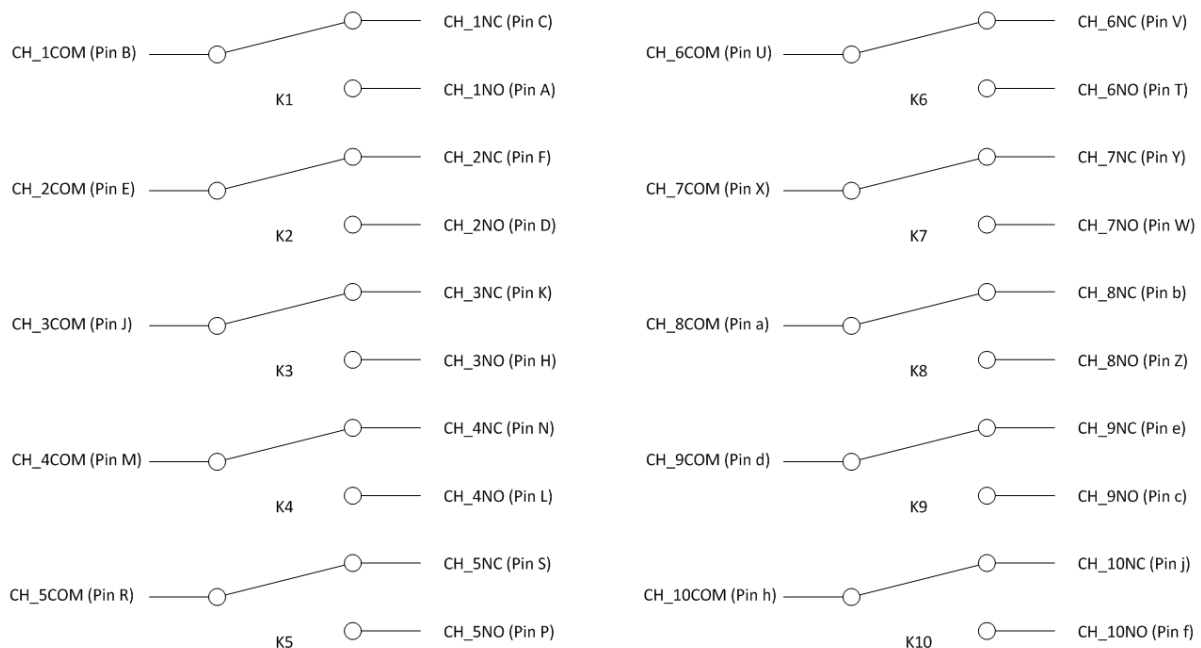

FIGURE 3-11: SMX-2002-10 LOGICAL DIAGRAM

SMX-2002-10 SPECIFICATIONS

GENERAL SPECIFICATIONS	
CHANNEL COUNT	10 SPDT
RELAY TYPE	Electromechanical, Power Relay
MAXIMUM SWITCHING VOLTAGE	300 V dc*, 250 V ac
MAXIMUM SWITCHING CURRENT	16 A
MAXIMUM SWITCHING POWER	448 W*, 4000 VA Breaking capacity
RATED SWITCH OPERATIONS	
Mechanical	>30 x 10 ⁶
Electrical	>1 x 10 ⁴
SWITCHING TIME	< 14 ms
PATH RESISTANCE	<100 mΩ
MAXIMUM THERMAL OFFSET PER CHANNEL (HI-LO)	< 30 μV
CAPACITANCE	
Open channel	<61 pF
Channel-mainframe	<76 pF
BANDWIDTH (-3 dB)	45 MHz (best)
INSERTION LOSS (TYPICAL)	
100 kHz	< 0.41 dB
1 MHz	< 0.45 dB
10 MHz	< 0.6 dB
CROSSTALK (TYPICAL)	
100 kHz	< -63 dB
1 MHz	< -53 dB
ISOLATION (TYPICAL)	
100 kHz	< -72 dB
1 MHz	< -52 dB

* For DC Voltage and Current, refer Figure 3-12.

FOR MATING CONNECTOR, CRIMP PINS, AND OTHER ACCESSORIES, PLEASE REFER TO *APPENDIX B*

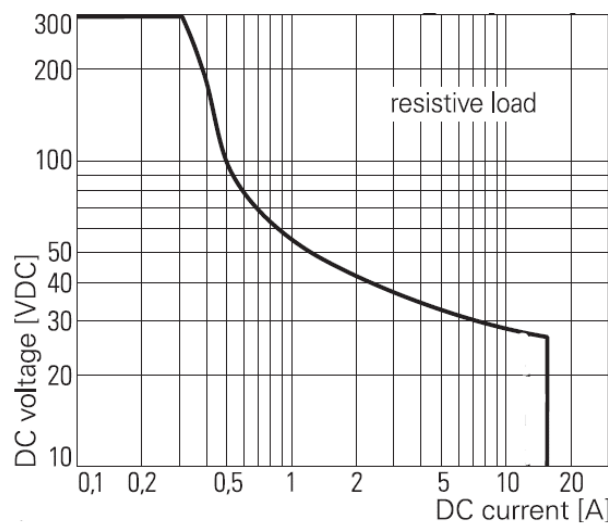

Figure 3-12: Max. DC load breaking capacity

SMX-2002-12 SWITCH MODULE

12-CHANNEL 16 A FORM C (SPDT) SWITCH

The SMX-2002-12 is a PXIe SPDT switch module capable of switching up to 16 A. As a high current switch module, possible applications include AC line power switching; switching AC or DC power supplies; controlling/driving relays for industrial machines, such as robotics and numerical control machines; automotive engine control; and solenoid switching.

The digital input lines on the SMX-2002-12 front panel allow the user to isolate the UUT and/or interface by forcing all relays to their normally open state when a fault condition occurs. This approach instantly removes all power to the switches and the UUT/interface is functionally disconnected from the switch module.

All relays are independently controlled. The SMX-2002-12 can be programmatically controlled using IviSwitch-complaint calls. Both path-level programming and individual relay control are available. 3-13 provides the Front Panel Connector detail followed by the Pin outs. Logical diagram of Switch module is represented in 3-14. This information can be used for individual relay control through the driver.

CONNECTOR PINS AND SIGNALS

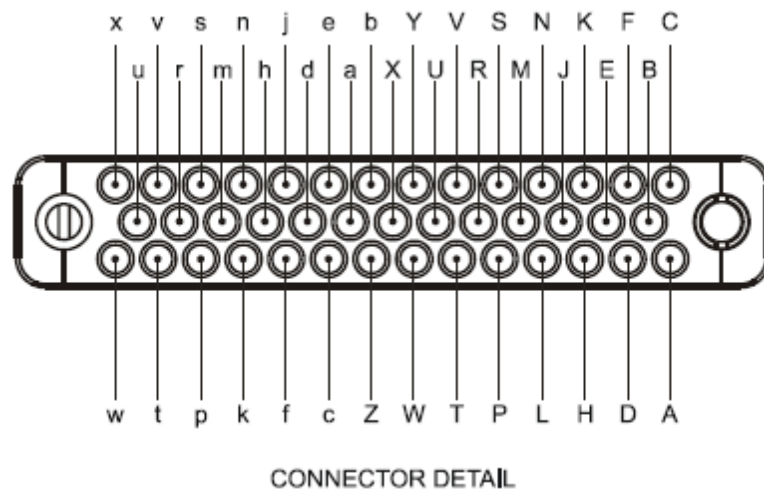

FIGURE 3-13: SMX-2002-12 FRONT PANEL (FRONT VIEW)

NOTE Pin x is connected to a shield layer located directly under the relays and connecting wires. Optimum performance is obtained when Pin x is tied to system or chassis ground and the front panel mounting screws are secured to the chassis frame.

POWER REQUIREMENTS

5Vaux	3P3V	12VP
0	0.726 W	6.5W

12 CH SPDT					
PIN	SIGNAL	PIN	SIGNAL	PIN	SIGNAL
A	CH_1NO	B	CH_1COM	C	CH_1NC
D	CH_2NO	E	CH_2COM	F	CH_2NC
H	CH_3NO	J	CH_3COM	K	CH_3NC
L	CH_4NO	M	CH_4COM	N	CH_4NC
P	CH_5NO	R	CH_5COM	S	CH_5NC
T	CH_6NO	U	CH_6COM	V	CH_6NC
W	CH_7NO	X	CH_7COM	Y	CH_7NC
Z	CH_8NO	a	CH_8COM	b	CH_8NC
c	CH_9NO	d	CH_9COM	e	CH_9NC
f	CH_10NO	h	CH_10COM	j	CH_10NC
k	CH_11NO	m	CH_11COM	n	CH_11NC
p	CH_12NO	r	CH_12COM	s	CH_12NC
t	FP_OPEN	u	unused	v	unused
w	FP_GND	x	CUS_SHIELD		

TABLE 3-5: CONNECTOR PINS & SIGNAL ASSIGNMENTS

On the SMX-2002-12 Front Panel there are two pins for access to the Front Panel Open signal of the module. These are Front Panel Open signal pin (FP_OPEN) and Ground reference pin (FP_GND). The purpose of the Front Panel Open signal is to allow user access to a configurable interlock feature that will reset all of the SMX-2002-12 relays. By default, FP_OPEN feature will be disabled. Through driver API user can enable this feature. FP_OPEN can be configured to either LEVEL or EDGE, once asserted FP_OPEN signal status will be latched which can be cleared using a reset command.

LOGICAL DIAGRAM

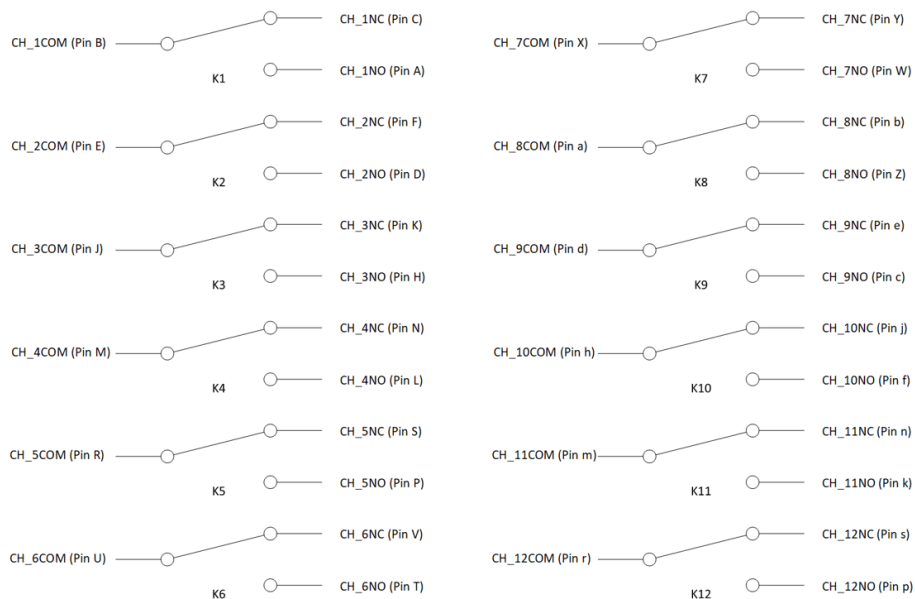

FIGURE 3-14: SMX-2002-12 LOGICAL DIAGRAM

SMX-2002-12 SPECIFICATIONS

GENERAL SPECIFICATIONS	
CHANNEL COUNT	12 SPDT
RELAY TYPE	Electromechanical, Power Relay
MAXIMUM SWITCHING VOLTAGE	300 V dc*, 250 V ac
MAXIMUM SWITCHING CURRENT	16 A
MAXIMUM SWITCHING POWER	448 W*, 4000 VA Breaking capacity
RATED SWITCH OPERATIONS	
Mechanical	>30 x 10 ⁶
Electrical	>1 x 10 ⁴
SWITCHING TIME	< 14 ms
PATH RESISTANCE	<100 mΩ
MAXIMUM THERMAL OFFSET PER CHANNEL (HI-LO)	< 30 μV
CAPACITANCE	
Open channel	<61 pF
Channel-mainframe	<76 pF
BANDWIDTH (-3 dB)	45 MHz (best)
INSERTION LOSS (TYPICAL)	
100 kHz	< 0.41 dB
1 MHz	< 0.45 dB
10 MHz	< 0.6 dB
CROSSTALK (TYPICAL)	
100 kHz	< -63 dB
1 MHz	< -53 dB
ISOLATION (TYPICAL)	
100 kHz	< -72 dB
1 MHz	< -52 dB

* For DC Voltage and Current, refer Figure 3-15.

FOR MATING CONNECTOR, CRIMP PINS, AND OTHER ACCESSORIES, PLEASE REFER TO *APPENDIX B*

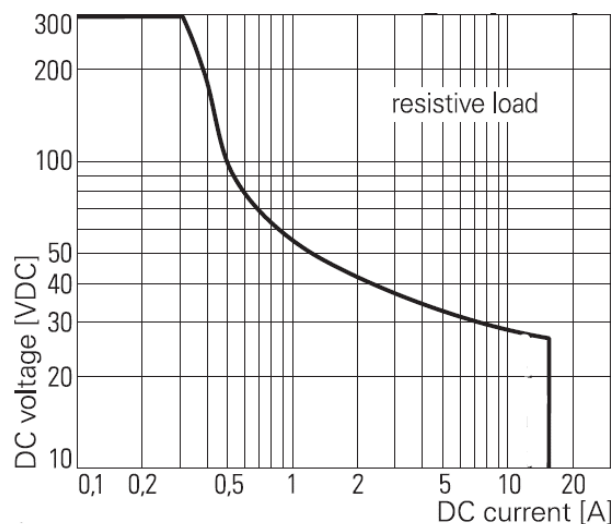

Figure 3-15: Max. DC load breaking capacity

SMX-3001 SWITCH MODULE

(8) 1 x 8 2-WIRE FULLY CONFIGURABLE MULTIPLEXER

The SMX-3001 high-density multiplexer module consists of eight individual (1 x 8) 2-wire multiplexers or eight (1 x 16) 1-wire multiplexers that can be interconnected under program control (via the bussing relays) to configure larger multiplexers as required. This eliminates external wiring and helps reduce unterminated stubs.

The SMX-3001 can be controlled programmatically using IviSwtch-compliant calls. Both path level programming and individual relay control are available. Refer to the host driver documentation for additional details. Figure 3-17 provides a logical diagram of the switch module and identifies the switches used by the module. This information can be used for individual relay control through the driver. An optional terminal block provides screw termination points for external field wiring. This terminal block also includes cold junction compensation reference for more precise temperature measurements.

CONNECTOR PINS AND SIGNALS

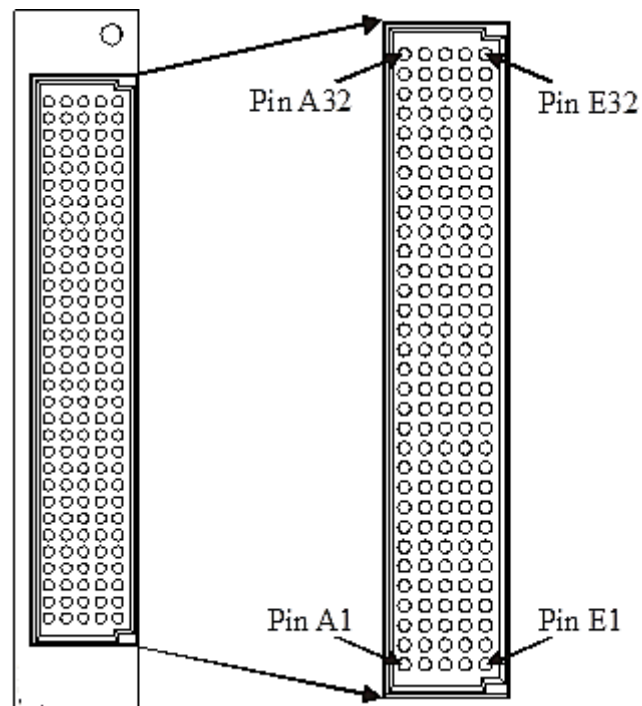

FIGURE 3-16: SMX-3001 FRONT PANEL CONNECTOR PINS (FRONT VIEW)

Row A		Row B		Row C		Row D		Row E	
Pin	Signal	Pin	Signal	Pin	Signal	Pin	Signal	Pin	Signal
1	CH1_1W	1	CH1_COMH	1	CH1_1H	1	CH1_2H	1	CH1_3H
2	SHIELD	2	CH1_COML	2	CH1_1L	2	CH1_2L	2	CH1_3L
3	CH1_4H	3	CH1_5H	3	CH1_6H	3	CH1_7H	3	CH1_8H
4	CH1_4L	4	CH1_5L	4	CH1_6L	4	CH1_7L	4	CH1_8L
5	CH2_1W	5	CH2_COMH	5	CH2_1H	5	CH2_2H	5	CH2_3H
6	SHIELD	6	CH2_COML	6	CH2_1L	6	CH2_2L	6	CH2_3L
7	CH2_4H	7	CH2_5H	7	CH2_6H	7	CH2_7H	7	CH2_8H
8	CH2_4L	8	CH2_5L	8	CH2_6L	8	CH2_7L	8	CH2_8L
9	CH3_1W	9	CH3_COMH	9	CH3_1H	9	CH3_2H	9	CH3_3H
10	SHIELD	10	CH3_COML	10	CH3_1L	10	CH3_2L	10	CH3_3L
11	CH3_4H	11	CH3_5H	11	CH3_6H	11	CH3_7H	11	CH3_8H
12	CH3_4L	12	CH3_5L	12	CH3_6L	12	CH3_7L	12	CH3_8L
13	CH4_1W	13	CH4_COMH	13	CH4_1H	13	CH4_2H	13	CH4_3H
14	SHIELD	14	CH4_COML	14	CH4_1L	14	CH4_2L	14	CH4_3L
15	CH4_4H	15	CH4_5H	15	CH4_6H	15	CH4_7H	15	CH4_8H
16	CH4_4L	16	CH4_5L	16	CH4_6L	16	CH4_7L	16	CH4_8L
17	CH5_1W	17	CH5_COMH	17	CH5_1H	17	CH5_2H	17	CH5_3H
18	SHIELD	18	CH5_COML	18	CH5_1L	18	CH5_2L	18	CH5_3L
19	CH5_4H	19	CH5_5H	19	CH5_6H	19	CH5_7H	19	CH5_8H
20	CH5_4L	20	CH5_5L	20	CH5_6L	20	CH5_7L	20	CH5_8L
21	CH6_1W	21	CH6_COMH	21	CH6_1H	21	CH6_2H	21	CH6_3H
22	SHIELD	22	CH6_COML	22	CH6_1L	22	CH6_2L	22	CH6_3L
23	CH6_4H	23	CH6_5H	23	CH6_6H	23	CH6_7H	23	CH6_8H
24	CH6_4L	24	CH6_5L	24	CH6_6L	24	CH6_7L	24	CH6_8L
25	CH7_1W	25	CH7_COMH	25	CH7_1H	25	CH7_2H	25	CH7_3H
26	CH7_4H	26	CH7_COML	26	CH7_1L	26	CH7_2L	26	CH7_3L
27	CH7_4L	27	CH7_5H	27	CH7_6H	27	CH7_7H	27	CH7_8H
28	CH8_1W	28	CH7_5L	28	CH7_6L	28	CH7_7L	28	CH7_8L
29	CH8_COMH	29	CH8_1H	29	CH8_2H	29	CH8_3H	29	CH8_4H
30	CH8_COML	30	CH8_1L	30	CH8_2L	30	CH8_3L	30	CH8_4L
31	CH8_5H	31	CH8_6H	31	CH8_7H	31	CH8_8H	31	SHIELD
32	CH8_5L	32	CH8_6L	32	CH8_7L	32	CH8_8L	32	UNUSED

TABLE 3-6: SMX-3001 CONNECTOR PINS & SIGNAL ASSIGNMENTS

The SMX-3001 incorporates an integral shield into the design of the PCB that attenuates noise and crosstalk between adjacent channels/modules. To properly utilize this feature, tie the appropriate front panel connector pins to the mating cable's common shield and/or ground. These pins are identified as "SHIELD" in Table 3-6.

LOGICAL DIAGRAM

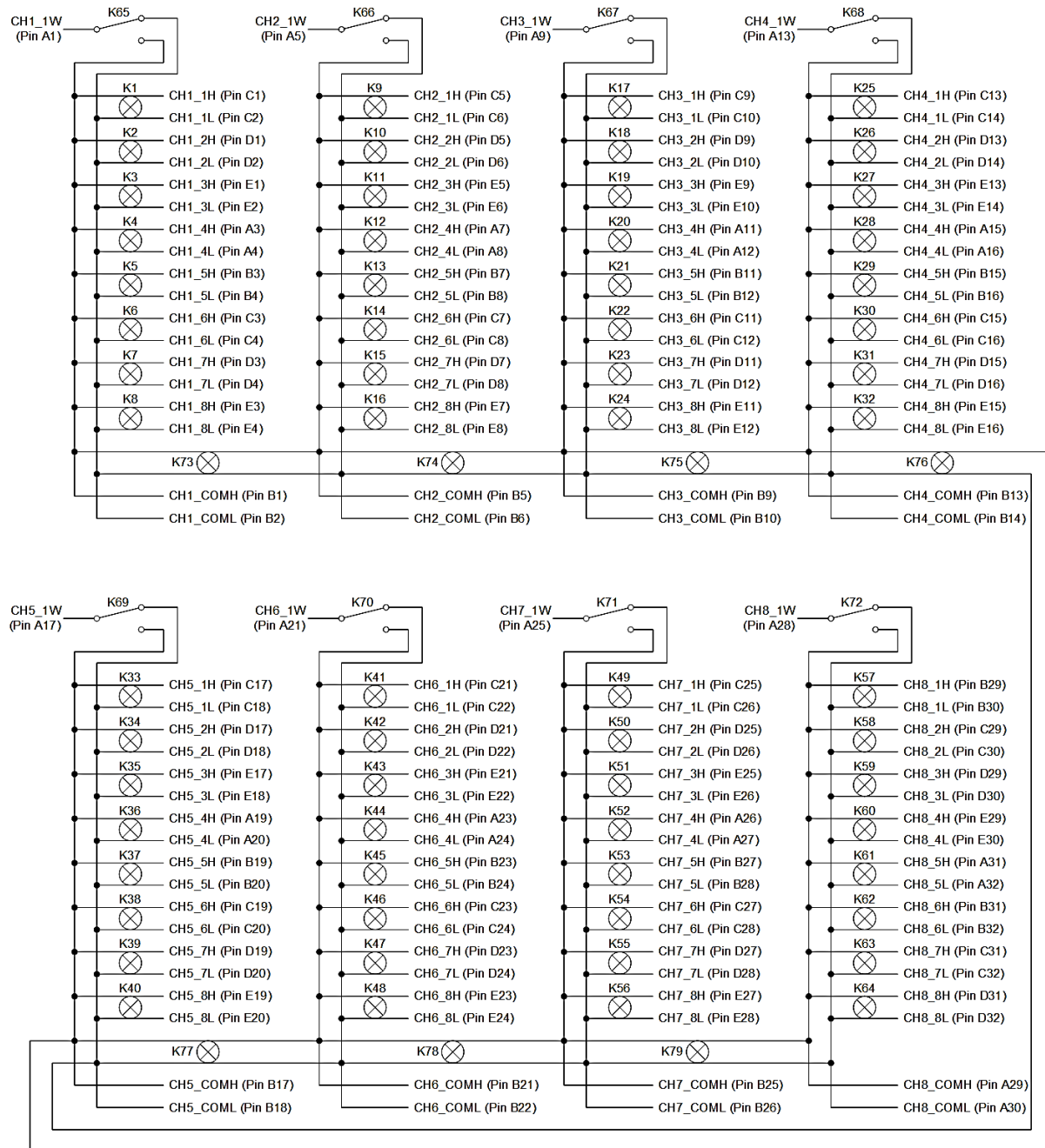

FIGURE 3-17: SMX-3001 LOGICAL DIAGRAM

TB Ref	Signal	Conn Pin	TB Ref	Signal	Conn Pin	TB Ref	Signal	Conn Pin	TB Ref	Signal	Conn Pin
T1	CH1_7L	D4	T41	CH7_7L	D28	T81	CH7_5L	B28	T121	CH6_1W	A21
T2	CH1_7H	D3	T42	CH7_7H	D27	T82	CH7_5H	B27	T122	SHIELD	A22
T3	CH2_2L	D6	T43	CH7_2L	D26	T83	CH8_1L	B30	T123	CH5_4H	A19
T4	CH2_2H	D5	T44	CH7_2H	D25	T84	CH8_1H	B29	T124	CH5_4L	A20
T5	CH2_7L	D8	T45	CH6_7L	D24	T85	CH8_6L	B32	T125	CH5_1W	A17
T6	CH2_7H	D7	T46	CH6_7H	D23	T86	CH8_6H	B31	T126	SHIELD	A18
T7	CH3_2L	D10	T47	CH6_2L	D22	T87	CH1_1L	C2	T127	CH4_4H	A15
T8	CH3_2H	D9	T48	CH6_2H	D21	T88	CH1_1H	C1	T128	CH4_4L	A16
T9	CH3_7L	D12	T49	CH5_5L	B20	T89	CH1_6L	C4	T129	CH7_8L	E28
T10	CH3_7H	D11	T50	CH5_5H	B19	T90	CH1_6H	C3	T130	CH7_8H	E27
T11	CH4_2L	D14	T51	CH1_1W	A1	T91	CH2_1L	C6	T131	CH7_3L	E26
T12	CH4_2H	D13	T52	SHIELD	A2	T92	CH2_1H	C5	T132	CH7_3H	E25
T13	CH4_7L	D16	T53	CH1_4H	A3	T93	CH2_6L	C8	T133	CH8_4L	E30
T14	CH4_7H	D15	T54	CH1_4L	A4	T94	CH2_6H	C7	T134	CH8_4H	E29
T15	CH5_2L	D18	T55	CH2_1W	A5	T95	CH3_1L	C10	T135	CH7_6L	C28
T16	CH5_2H	D17	T56	SHIELD	A6	T96	CH3_1H	C9	T136	CH7_6H	C27
T17	CH2_COML	B6	T57	CH2_4H	A7	T97	CH5_8L	E20	T137	CH8_2L	C30
T18	CH2_COMH	B5	T58	CH2_4L	A8	T98	CH5_8H	E19	T138	CH8_2H	C29
T19	CH1_5L	B4	T59	CH7_COML	B26	T99	CH4_8L	E16	T139	CH7_1H	C25
T20	CH1_5H	B3	T60	CH7_COMH	B25	T100	CH4_8H	E15	T140	CH7_1L	C26
T21	CH2_5L	B8	T61	CH6_5L	B24	T101	CH6_3L	E22	T141	CH6_6H	C23
T22	CH2_5H	B7	T62	CH6_5H	B23	T102	CH6_3H	E21	T142	CH6_6L	C24
T23	CH3_COML	B10	T63	CH6_COML	B22	T103	CH6_8L	E24	T143	CH5_1L	C18
T24	CH3_COMH	B9	T64	CH6_COMH	B21	T104	CH6_8H	E23	T144	CH5_1H	C17
T25	CH3_5L	B12	T65	CH8_3L	D30	T105	CH4_3L	E14	T145	CH6_1H	C21
T26	CH3_5H	B11	T66	CH8_3H	D29	T106	CH4_3H	E13	T146	CH6_1L	C22
T27	CH4_COML	B14	T67	CH8_8L	D32	T107	CH3_8L	E12	T147	CH5_6H	C19
T28	CH4_COMH	B13	T68	CH8_8H	D31	T108	CH3_8H	E11	T148	CH5_6L	C20
T29	CH4_5L	B16	T69	CH1_3L	E2	T109	CH3_3L	E10	T149	CH7_1W	A25
T30	CH4_5H	B15	T70	CH1_3H	E1	T110	CH3_3H	E9	T150	CH8_1W	A28
T31	CH5_COML	B18	T71	CH1_8L	E4	T111	CH2_8L	E8	T151	CH7_4H	A26
T32	CH5_COMH	B17	T72	CH1_8H	E3	T112	CH2_8H	E7	T152	CH7_4L	A27
T33	CH5_7L	D20	T73	CH2_3L	E6	T113	CH3_6L	C12	T153	CH8_COMH	A29
T34	CH5_7H	D19	T74	CH2_3H	E5	T114	CH3_6H	C11	T154	CH8_COML	A30
T35	CH3_1W	A9	T75	CH5_3H	E17	T115	CH4_1L	C14	T155	SHIELD	E31
T36	SHIELD	A10	T76	CH5_3L	E18	T116	CH4_1H	C13	T156	GND_C	E32
T37	CH3_4H	A11	T77	CH1_2L	D2	T117	CH4_6L	C16	T157	CH8_7H	C31
T38	CH3_4L	A12	T78	CH1_2H	D1	T118	CH4_6H	C15	T158	CH8_7L	C32
T39	CH4_1W	A13	T79	CH1_COML	B2	T119	CH6_4H	A23	T159	CH8_5H	A31
T40	SHIELD	A14	T80	CH1_COMH	B1	T120	CH6_4L	A24	T160	CH8_5L	A32

TABLE 3-7: EX1200-TB160-3 TERMINAL BLOCK TO SMX-3001 PIN MAPPING

SMX-3001 SPECIFICATIONS

GENERAL SPECIFICATIONS	
CHANNEL COUNT	(8) 1 x 8 2-wire Multiplexer, Fully configurable
RELAY TYPE	Electromechanical, fail-safe
MAXIMUM SWITCHING VOLTAGE	300 V ac, 300 V dc
MAXIMUM SWITCHING CURRENT	2 A
MAXIMUM SWITCHING POWER	60 W dc, 62.5 VA
	<i>*Maximum switched power is at 30 V/ 2 A dc. Max switched power is derated non-linearly as voltage is increased.</i>
RATED SWITCH OPERATIONS	
Mechanical	1 x 10 ⁸ (no load)
Electrical	Min. 1 x 10 ⁵ @ (resistive load, 250VAC/0.25A), (resistive load, 30VDC/2A)
SWITCHING TIME	< 8 ms
PATH RESISTANCE	< 400m Ω
INSULATION RESISTANCE	> 1 x 10 ⁹ Ω
MAXIMUM THERMAL OFFSET PER CHANNEL (HI-LO)	
	< 10 μV
CAPACITANCE	
Open channel_2 wire	< 14 pF
Channel-mainframe_2 wire	< 117 pF
High-low_2 wire	< 56 pF
BANDWIDTH (-3 dB)	
(8) 1 x 8 2-wire Multiplexer	109 MHz (typical), 110 MHz (best), 100 MHz (worst)
(8) 1 x 16 1-wire Multiplexer	41 MHz (best), 40 MHz (worst)
INSERTION LOSS	
100 kHz_ 2wire	< 0.2 dB
1 MHz_ 2wire	< 0.6 dB
10 MHz_ 2wire	< 0.6 dB
100 kHz_ 1wire	< 0.1 dB
1 MHz_ 1wire	< 0.7 dB
100 kHz_ 1wire	< 0.9 dB
CROSSTALK	
100 kHz _ 2wire	< -71 dB
1 MHz _ 2wire	< -53 dB
100 kHz _ 1wire	< -69 dB
1 MHz _ 1wire	< -63 dB
ISOLATION	
100 kHz_ 2wire	< -58 dB
1 MHz_ 2wire	< -51 dB
100 kHz_ 1wire	< -59 dB
1 MHz_ 1wire	< -49 dB

FOR MATING CONNECTOR, CRIMP PINS, AND OTHER ACCESSORIES, PLEASE REFER TO *APPENDIX B*

SMX-3001DS SWITCH MODULE

(8) 1 x 8 2-WIRE FULLY CONFIGURABLE MULTIPLEXER

The SMX-3001DS high-density multiplexer module consists of eight individual (1 x 8) 2-wire multiplexers or eight (1 x 16) 1-wire multiplexers that can be interconnected under program control (via the bussing relays) to configure larger multiplexers as required. This eliminates external wiring and helps reduce unterminated stubs.

In contrast to the SMX-3001 the SMX-3001DS has internal residual voltage discharge relays that can be enabled to momentarily short out the measurement path when changing from one input channel to the next. This dissipates any voltage held by the wiring and instrument input capacitance. These relays protect sensitive devices, such as CMOS circuits, from residual voltages caused by previous high-voltage measurements. This feature can also be disabled in low-voltage applications where maximum throughput speed is important.

The SMX-3001DS can be controlled programmatically using IviSwch-compliant calls. Both path level programming and individual relay control are available. Refer to the host driver documentation for additional details. Figure 3-20 provides a logical diagram of the switch module and identifies the switches used by the module. This information can be used for individual relay control through the driver. An optional terminal block provides screw termination points for external field wiring. This terminal block also includes cold junction compensation reference for more precise temperature measurements.

NOTE SMX-3001DS where DS stands for DISCHARGE relays support

CONNECTOR PINS AND SIGNALS

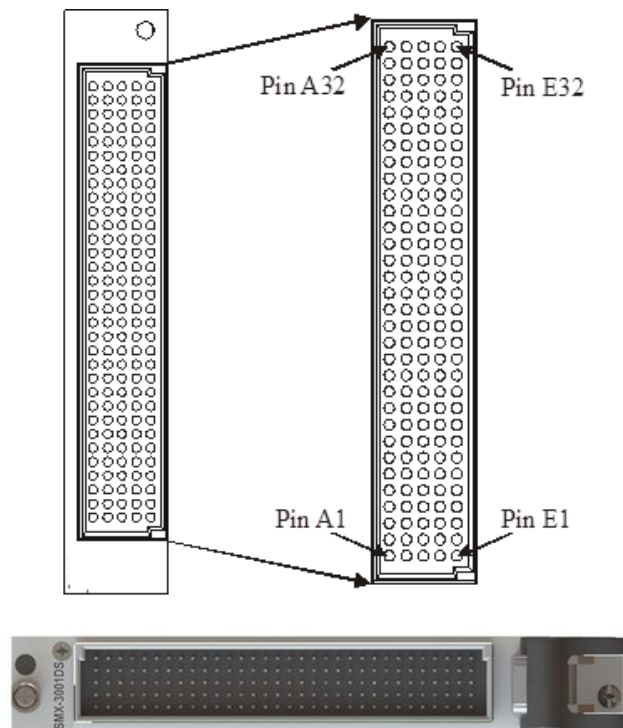

FIGURE 3-18: SMX-3001DS FRONT PANEL (FRONT VIEW)



FIGURE 3-19: SMX-3001DS CARD (ANGULAR VIEW)

Row A		Row B		Row C		Row D		Row E	
Pin	Signal	Pin	Signal	Pin	Signal	Pin	Signal	Pin	Signal
1	CH1_1W	1	CH1_COMH	1	CH1_1H	1	CH1_2H	1	CH1_3H
2	SHIELD	2	CH1_COML	2	CH1_1L	2	CH1_2L	2	CH1_3L
3	CH1_4H	3	CH1_5H	3	CH1_6H	3	CH1_7H	3	CH1_8H
4	CH1_4L	4	CH1_5L	4	CH1_6L	4	CH1_7L	4	CH1_8L
5	CH2_1W	5	CH2_COMH	5	CH2_1H	5	CH2_2H	5	CH2_3H
6	SHIELD	6	CH2_COML	6	CH2_1L	6	CH2_2L	6	CH2_3L
7	CH2_4H	7	CH2_5H	7	CH2_6H	7	CH2_7H	7	CH2_8H
8	CH2_4L	8	CH2_5L	8	CH2_6L	8	CH2_7L	8	CH2_8L
9	CH3_1W	9	CH3_COMH	9	CH3_1H	9	CH3_2H	9	CH3_3H
10	SHIELD	10	CH3_COML	10	CH3_1L	10	CH3_2L	10	CH3_3L
11	CH3_4H	11	CH3_5H	11	CH3_6H	11	CH3_7H	11	CH3_8H
12	CH3_4L	12	CH3_5L	12	CH3_6L	12	CH3_7L	12	CH3_8L
13	CH4_1W	13	CH4_COMH	13	CH4_1H	13	CH4_2H	13	CH4_3H
14	SHIELD	14	CH4_COML	14	CH4_1L	14	CH4_2L	14	CH4_3L
15	CH4_4H	15	CH4_5H	15	CH4_6H	15	CH4_7H	15	CH4_8H
16	CH4_4L	16	CH4_5L	16	CH4_6L	16	CH4_7L	16	CH4_8L
17	CH5_1W	17	CH5_COMH	17	CH5_1H	17	CH5_2H	17	CH5_3H
18	SHIELD	18	CH5_COML	18	CH5_1L	18	CH5_2L	18	CH5_3L
19	CH5_4H	19	CH5_5H	19	CH5_6H	19	CH5_7H	19	CH5_8H
20	CH5_4L	20	CH5_5L	20	CH5_6L	20	CH5_7L	20	CH5_8L
21	CH6_1W	21	CH6_COMH	21	CH6_1H	21	CH6_2H	21	CH6_3H
22	SHIELD	22	CH6_COML	22	CH6_1L	22	CH6_2L	22	CH6_3L
23	CH6_4H	23	CH6_5H	23	CH6_6H	23	CH6_7H	23	CH6_8H
24	CH6_4L	24	CH6_5L	24	CH6_6L	24	CH6_7L	24	CH6_8L
25	CH7_1W	25	CH7_COMH	25	CH7_1H	25	CH7_2H	25	CH7_3H
26	CH7_4H	26	CH7_COML	26	CH7_1L	26	CH7_2L	26	CH7_3L
27	CH7_4L	27	CH7_5H	27	CH7_6H	27	CH7_7H	27	CH7_8H
28	CH8_1W	28	CH7_5L	28	CH7_6L	28	CH7_7L	28	CH7_8L
29	CH8_COMH	29	CH8_1H	29	CH8_2H	29	CH8_3H	29	CH8_4H
30	CH8_COML	30	CH8_1L	30	CH8_2L	30	CH8_3L	30	CH8_4L
31	CH8_5H	31	CH8_6H	31	CH8_7H	31	CH8_8H	31	SHIELD
32	CH8_5L	32	CH8_6L	32	CH8_7L	32	CH8_8L	32	UNUSED

TABLE 3-8: SMX-3001DS CONNECTOR PINS & SIGNAL ASSIGNMENTS

The SMX-3001DS incorporates an integral shield into the design of the PCB that attenuates noise and crosstalk between adjacent channels/modules. To properly utilize this feature, tie the appropriate front panel connector pins to the mating cable's common shield and/or ground. These pins are identified as "SHIELD" in Table 3-8.

LOGICAL DIAGRAM

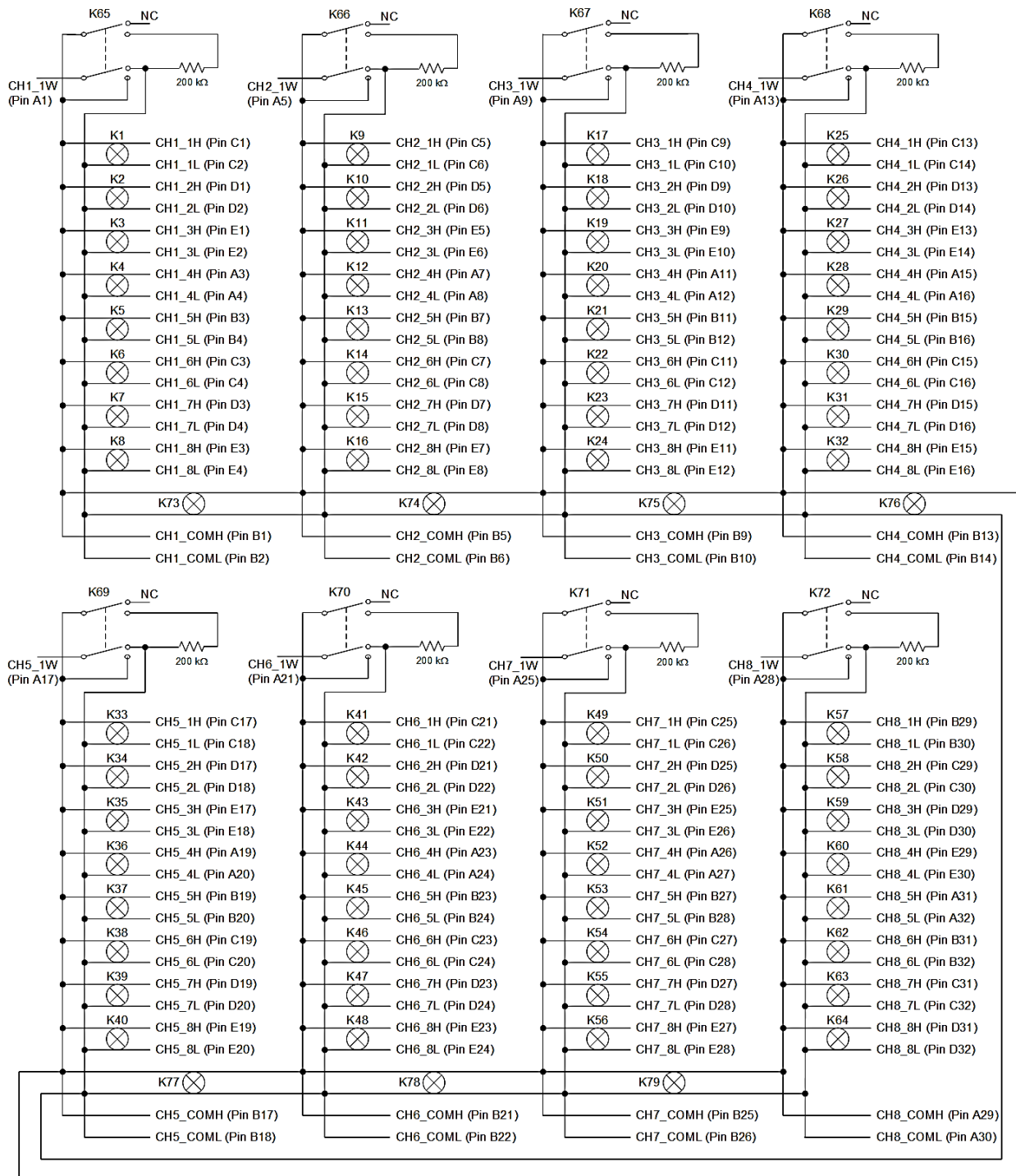

FIGURE 3-20: SMX-3001DS LOGICAL DIAGRAM

SMX-3001DS SPECIFICATIONS

GENERAL SPECIFICATIONS	
CHANNEL COUNT	(8) 1 x 8 2-wire Multiplexer, Fully configurable
RELAY TYPE	Electromechanical, fail-safe
MAXIMUM SWITCHING VOLTAGE	300 V ac, 300 V dc
MAXIMUM SWITCHING CURRENT	2 A
MAXIMUM SWITCHING POWER	60 W dc, 62.5 VA
	<i>*Maximum switched power is at 30 V/ 2 A dc. Max switched power is derated non-linearly as voltage is increased.</i>
RATED SWITCH OPERATIONS	
Mechanical	1 x 10 ⁸ (no load)
Electrical	Min. 1 x 10 ⁵ @ (resistive load, 250VAC/0.25A), (resistive load, 30VDC/2A)
SWITCHING TIME	< 8 ms
PATH RESISTANCE	< 400m Ω
INSULATION RESISTANCE	> 1 x 10 ⁹ Ω
MAXIMUM THERMAL OFFSET PER CHANNEL (HI-LO)	
	< 10 μV
CAPACITANCE	
Open channel_2 wire	< 14 pF
Channel-mainframe_2 wire	< 117 pF
High-low_2 wire	< 56 pF
BANDWIDTH (-3 dB)	
(8) 1 x 8 2-wire Multiplexer	109 MHz (typical), 110 MHz (best), 100 MHz (worst)
(8) 1 x 16 1-wire Multiplexer	41 MHz (best), 40 MHz (worst)
INSERTION LOSS	
100 kHz_ 2wire	< 0.2 dB
1 MHz_ 2wire	< 0.6 dB
10 MHz_ 2wire	< 0.6 dB
100 kHz_ 1wire	< 0.1 dB
1 MHz_ 1wire	< 0.7 dB
100 kHz_ 1wire	< 0.9 dB
CROSSTALK	
100 kHz _ 2wire	< -71 dB
1 MHz _ 2wire	< -53 dB
100 kHz _ 1wire	< -69 dB
1 MHz _ 1wire	< -63 dB
ISOLATION	
100 kHz_ 2wire	< -58 dB
1 MHz_ 2wire	< -51 dB
100 kHz_ 1wire	< -59 dB
1 MHz_ 1wire	< -49 dB

FOR MATING CONNECTOR, CRIMP PINS, AND OTHER ACCESSORIES, PLEASE REFER TO *APPENDIX B*

SMX-3002 SWITCH MODULE

(8) 1 x 8 2-WIRE FIXED MULTIPLEXER

The SMX-3002 high-density multiplexer module consists of eight individual (1 x 8) 2-wire multiplexers.

The SMX-3002 can be controlled programmatically using IviSwTch-compliant calls. Both path level programming and individual relay control are available. Refer to the host driver documentation for additional details. Figure 3-22 provides a logical diagram of the switch module and identifies the switches used by the module. This information can be used for individual relay control through the driver. An optional terminal block provides screw termination points for external field wiring. This terminal block also includes cold junction compensation reference for more precise temperature measurements.

CONNECTOR PINS AND SIGNALS

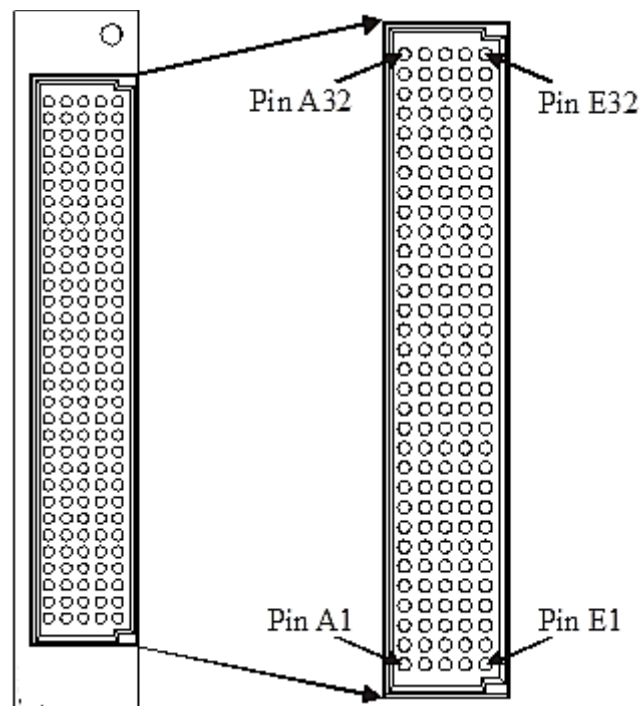

FIGURE 3-21: SMX-3002 FRONT PANEL CONNECTOR PINS (FRONT VIEW)

Row A		Row B		Row C		Row D		Row E	
Pin	Signal	Pin	Signal	Pin	Signal	Pin	Signal	Pin	Signal
1	UNUSED	1	CH1_COMH	1	CH1_1H	1	CH1_2H	1	CH1_3H
2	SHIELD	2	CH1_COML	2	CH1_1L	2	CH1_2L	2	CH1_3L
3	CH1_4H	3	CH1_5H	3	CH1_6H	3	CH1_7H	3	CH1_8H
4	CH1_4L	4	CH1_5L	4	CH1_6L	4	CH1_7L	4	CH1_8L
5	UNUSED	5	CH2_COMH	5	CH2_1H	5	CH2_2H	5	CH2_3H
6	SHIELD	6	CH2_COML	6	CH2_1L	6	CH2_2L	6	CH2_3L
7	CH2_4H	7	CH2_5H	7	CH2_6H	7	CH2_7H	7	CH2_8H
8	CH2_4L	8	CH2_5L	8	CH2_6L	8	CH2_7L	8	CH2_8L
9	UNUSED	9	CH3_COMH	9	CH3_1H	9	CH3_2H	9	CH3_3H
10	SHIELD	10	CH3_COML	10	CH3_1L	10	CH3_2L	10	CH3_3L
11	CH3_4H	11	CH3_5H	11	CH3_6H	11	CH3_7H	11	CH3_8H
12	CH3_4L	12	CH3_5L	12	CH3_6L	12	CH3_7L	12	CH3_8L
13	UNUSED	13	CH4_COMH	13	CH4_1H	13	CH4_2H	13	CH4_3H
14	SHIELD	14	CH4_COML	14	CH4_1L	14	CH4_2L	14	CH4_3L
15	CH4_4H	15	CH4_5H	15	CH4_6H	15	CH4_7H	15	CH4_8H
16	CH4_4L	16	CH4_5L	16	CH4_6L	16	CH4_7L	16	CH4_8L
17	UNUSED	17	CH5_COMH	17	CH5_1H	17	CH5_2H	17	CH5_3H
18	SHIELD	18	CH5_COML	18	CH5_1L	18	CH5_2L	18	CH5_3L
19	CH5_4H	19	CH5_5H	19	CH5_6H	19	CH5_7H	19	CH5_8H
20	CH5_4L	20	CH5_5L	20	CH5_6L	20	CH5_7L	20	CH5_8L
21	UNUSED	21	CH6_COMH	21	CH6_1H	21	CH6_2H	21	CH6_3H
22	SHIELD	22	CH6_COML	22	CH6_1L	22	CH6_2L	22	CH6_3L
23	CH6_4H	23	CH6_5H	23	CH6_6H	23	CH6_7H	23	CH6_8H
24	CH6_4L	24	CH6_5L	24	CH6_6L	24	CH6_7L	24	CH6_8L
25	UNUSED	25	CH7_COMH	25	CH7_1H	25	CH7_2H	25	CH7_3H
26	CH7_4H	26	CH7_COML	26	CH7_1L	26	CH7_2L	26	CH7_3L
27	CH7_4L	27	CH7_5H	27	CH7_6H	27	CH7_7H	27	CH7_8H
28	UNUSED	28	CH7_5L	28	CH7_6L	28	CH7_7L	28	CH7_8L
29	CH8_COMH	29	CH8_1H	29	CH8_2H	29	CH8_3H	29	CH8_4H
30	CH8_COML	30	CH8_1L	30	CH8_2L	30	CH8_3L	30	CH8_4L
31	CH8_5H	31	CH8_6H	31	CH8_7H	31	CH8_8H	31	SHIELD
32	CH8_5L	32	CH8_6L	32	CH8_7L	32	CH8_8L	32	UNUSED

TABLE 3-9: SMX-3002 PINS & SIGNAL ASSIGNMENTS

The SMX-3002 incorporates an integral shield into the design of the PCB that attenuates noise and crosstalk between adjacent channels/modules. To properly utilize this feature, tie the appropriate front panel connector pins to the mating cable's common shield and/or ground. These pins are identified as "SHIELD" in Table 3-9

LOGICAL DIAGRAM

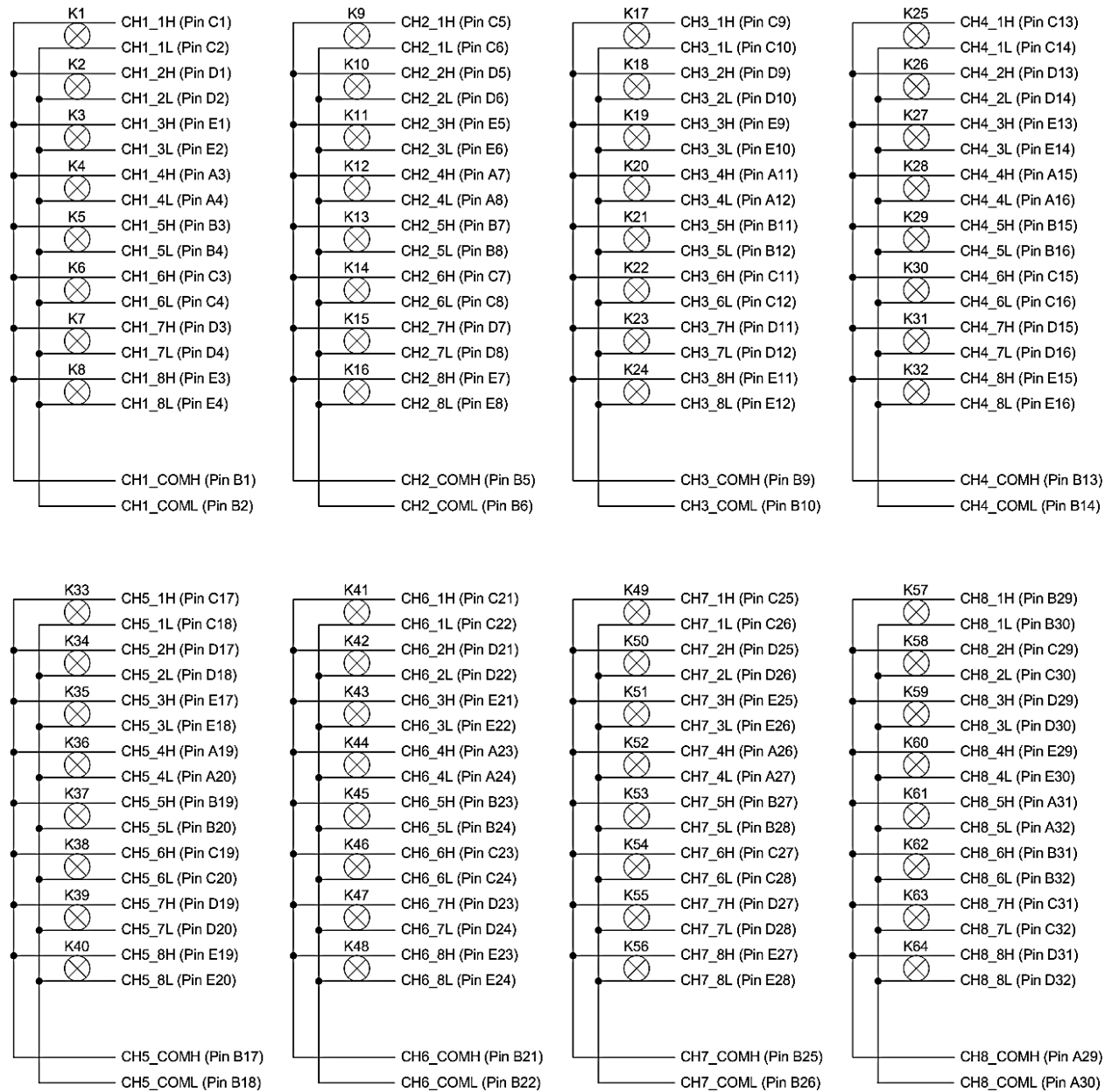

FIGURE 3-22: SMX-3002 LOGICAL DIAGRAM

SMX-3002 SPECIFICATIONS

GENERAL SPECIFICATIONS	
CHANNEL COUNT	(8) 1 x 8 2-wire Fixed Multiplexer
RELAY TYPE	Electromechanical, fail-safe
MAXIMUM SWITCHING VOLTAGE	300 V ac, 300 V dc
MAXIMUM SWITCHING CURRENT	2 A
MAXIMUM SWITCHING POWER	60 W dc, 62.5 VA
	<i>*Maximum switched power is at 30 V/ 2 A dc. Max switched power is derated non-linearly as voltage is increased.</i>
RATED SWITCH OPERATIONS	
Mechanical	1 x 10 ⁸ (no load)
Electrical	Min. 1 x 10 ⁵ @ (resistive load, 250VAC/0.25A), (resistive load, 30VDC/2A)
SWITCHING TIME	< 8 ms
PATH RESISTANCE	< 400mΩ
INSULATION RESISTANCE	> 1 x 10 ⁹ Ω
MAXIMUM THERMAL OFFSET PER CHANNEL (HI-LO)	
	< 10 μV
CAPACITANCE	
Open channel	< 14 pF
Channel-mainframe	< 108 pF
High-low	< 52 pF
BANDWIDTH (-3 dB)	
	110 MHz (typical), 114 MHz (best), 106 MHz (worst)
INSERTION LOSS	
100 kHz	< 0.25 dB
1 MHz	< 0.33 dB
10 MHz	< 0.7 dB
CROSSTALK	
100 kHz	< -70 dB
1 MHz	< -62 dB
ISOLATION	
100 kHz	< -62 dB
1 MHz	< -62 dB

FOR MATING CONNECTOR, CRIMP PINS, AND OTHER ACCESSORIES, PLEASE REFER TO *APPENDIX B*

SMX-3002DS SWITCH MODULE

(8) 1 x 8 2-WIRE FIXED MULTIPLEXER

The SMX-3002DS high-density multiplexer module consists of eight individual (1 x 8) 2-wire multiplexers.

In contrast to the SMX-3002 the SMX-3002DS has internal residual voltage discharge relays that can be enabled to momentarily short out the measurement path when changing from one input channel to the next. This dissipates any voltage held by the wiring and instrument input capacitance. These relays protect sensitive devices, such as CMOS circuits, from residual voltages caused by previous high-voltage measurements. This feature can also be disabled in low-voltage applications where maximum throughput speed is important.

The SMX-3002DS can be controlled programmatically using IviSwch-compliant calls. Both path level programming and individual relay control are available. Refer to the host driver documentation for additional details. Figure 3-24 provides a logical diagram of the switch module and identifies the switches used by the module. This information can be used for individual relay control through the driver. An optional terminal block provides screw termination points for external field wiring. This terminal block also includes cold junction compensation reference for more precise temperature measurements.

NOTE SMX-3002DS where DS stands for DISCHARGE relays support

CONNECTOR PINS AND SIGNALS

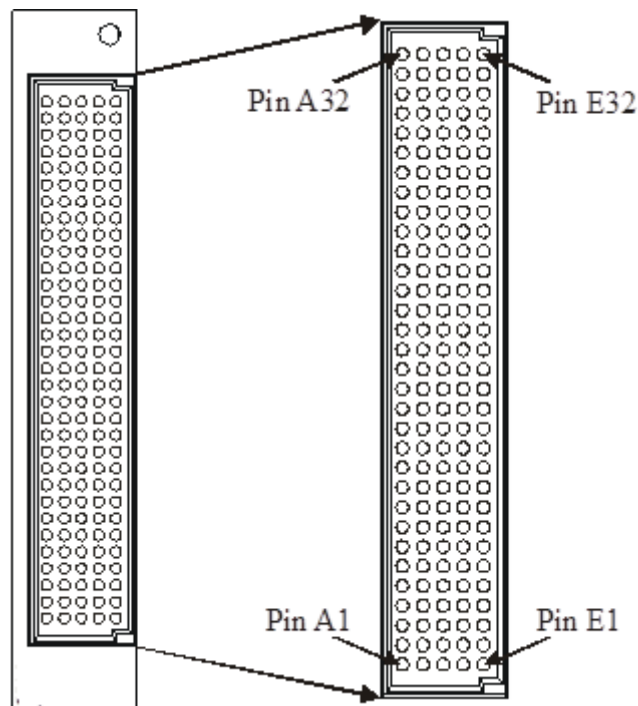

FIGURE 3-23: SMX-3002DS FRONT PANEL (FRONT VIEW)

Row A		Row B		Row C		Row D		Row E	
Pin	Signal	Pin	Signal	Pin	Signal	Pin	Signal	Pin	Signal
1	UNUSED	1	CH1_COMH	1	CH1_1H	1	CH1_2H	1	CH1_3H
2	SHIELD	2	CH1_COML	2	CH1_1L	2	CH1_2L	2	CH1_3L
3	CH1_4H	3	CH1_5H	3	CH1_6H	3	CH1_7H	3	CH1_8H
4	CH1_4L	4	CH1_5L	4	CH1_6L	4	CH1_7L	4	CH1_8L
5	UNUSED	5	CH2_COMH	5	CH2_1H	5	CH2_2H	5	CH2_3H
6	SHIELD	6	CH2_COML	6	CH2_1L	6	CH2_2L	6	CH2_3L
7	CH2_4H	7	CH2_5H	7	CH2_6H	7	CH2_7H	7	CH2_8H
8	CH2_4L	8	CH2_5L	8	CH2_6L	8	CH2_7L	8	CH2_8L
9	UNUSED	9	CH3_COMH	9	CH3_1H	9	CH3_2H	9	CH3_3H
10	SHIELD	10	CH3_COML	10	CH3_1L	10	CH3_2L	10	CH3_3L
11	CH3_4H	11	CH3_5H	11	CH3_6H	11	CH3_7H	11	CH3_8H
12	CH3_4L	12	CH3_5L	12	CH3_6L	12	CH3_7L	12	CH3_8L
13	UNUSED	13	CH4_COMH	13	CH4_1H	13	CH4_2H	13	CH4_3H
14	SHIELD	14	CH4_COML	14	CH4_1L	14	CH4_2L	14	CH4_3L
15	CH4_4H	15	CH4_5H	15	CH4_6H	15	CH4_7H	15	CH4_8H
16	CH4_4L	16	CH4_5L	16	CH4_6L	16	CH4_7L	16	CH4_8L
17	UNUSED	17	CH5_COMH	17	CH5_1H	17	CH5_2H	17	CH5_3H
18	SHIELD	18	CH5_COML	18	CH5_1L	18	CH5_2L	18	CH5_3L
19	CH5_4H	19	CH5_5H	19	CH5_6H	19	CH5_7H	19	CH5_8H
20	CH5_4L	20	CH5_5L	20	CH5_6L	20	CH5_7L	20	CH5_8L
21	UNUSED	21	CH6_COMH	21	CH6_1H	21	CH6_2H	21	CH6_3H
22	SHIELD	22	CH6_COML	22	CH6_1L	22	CH6_2L	22	CH6_3L
23	CH6_4H	23	CH6_5H	23	CH6_6H	23	CH6_7H	23	CH6_8H
24	CH6_4L	24	CH6_5L	24	CH6_6L	24	CH6_7L	24	CH6_8L
25	UNUSED	25	CH7_COMH	25	CH7_1H	25	CH7_2H	25	CH7_3H
26	CH7_4H	26	CH7_COML	26	CH7_1L	26	CH7_2L	26	CH7_3L
27	CH7_4L	27	CH7_5H	27	CH7_6H	27	CH7_7H	27	CH7_8H
28	UNUSED	28	CH7_5L	28	CH7_6L	28	CH7_7L	28	CH7_8L
29	CH8_COMH	29	CH8_1H	29	CH8_2H	29	CH8_3H	29	CH8_4H
30	CH8_COML	30	CH8_1L	30	CH8_2L	30	CH8_3L	30	CH8_4L
31	CH8_5H	31	CH8_6H	31	CH8_7H	31	CH8_8H	31	SHIELD
32	CH8_5L	32	CH8_6L	32	CH8_7L	32	CH8_8L	32	UNUSED

TABLE 3-10: SMX-3002DS CONNECTOR PINS & SIGNAL ASSIGNMENTS

The SMX-3002DS incorporates an integral shield into the design of the PCB that attenuates noise and crosstalk between adjacent channels/modules. To properly utilize this feature, tie the appropriate front panel connector pins to the mating cable's common shield and/or ground. These pins are identified as "SHIELD" in Table 3-10

LOGICAL DIAGRAM

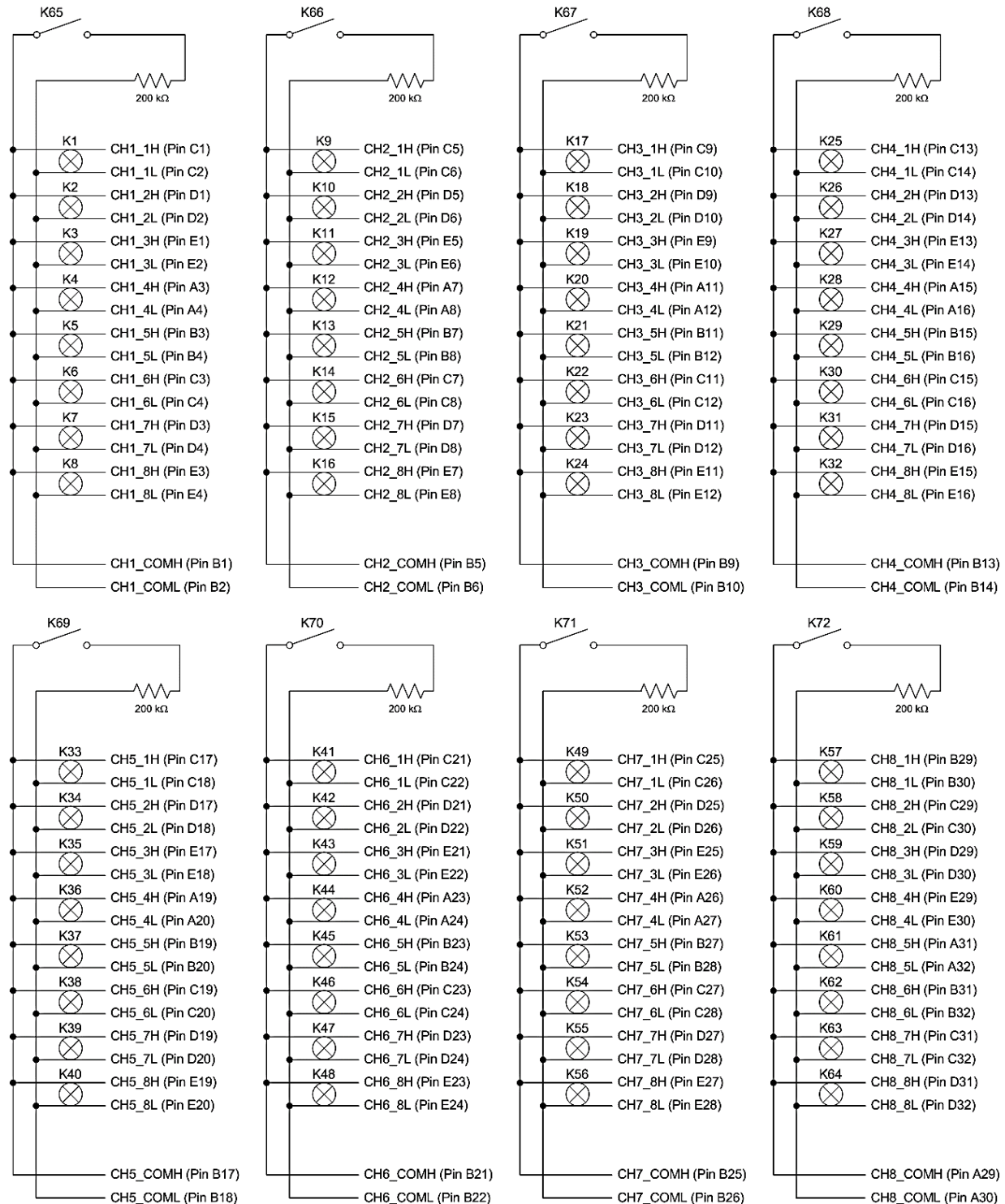

FIGURE 3-24: SMX-3002DS LOGICAL DIAGRAM

SMX-3002DS SPECIFICATIONS

GENERAL SPECIFICATIONS	
CHANNEL COUNT	(8) 1 x 8 2-wire Fixed Multiplexer
RELAY TYPE	Electromechanical, fail-safe
MAXIMUM SWITCHING VOLTAGE	300 V ac, 300 V dc
MAXIMUM SWITCHING CURRENT	2 A
MAXIMUM SWITCHING POWER	60 W dc, 62.5 VA
	<i>*Maximum switched power is at 30 V/ 2 A dc. Max switched power is derated non-linearly as voltage is increased.</i>
RATED SWITCH OPERATIONS	
Mechanical	1 x 10 ⁸ (no load)
Electrical	Min. 1 x 10 ⁵ @ (resistive load, 250VAC/0.25A), (resistive load, 30VDC/2A)
SWITCHING TIME	< 8 ms
PATH RESISTANCE	< 400mΩ
INSULATION RESISTANCE	> 1 x 10 ⁹ Ω
MAXIMUM THERMAL OFFSET PER CHANNEL (HI-LO)	
	< 10 μV
CAPACITANCE	
Open channel	< 14 pF
Channel-mainframe	< 108 pF
High-low	< 52 pF
BANDWIDTH (-3 dB)	
	110 MHz (typical), 114 MHz (best), 106 MHz (worst)
INSERTION LOSS	
100 kHz	< 0.25 dB
1 MHz	< 0.33 dB
10 MHz	< 0.7 dB
CROSSTALK	
100 kHz	< -70 dB
1 MHz	< -62 dB
ISOLATION	
100 kHz	< -62 dB
1 MHz	< -62 dB

FOR MATING CONNECTOR, CRIMP PINS, AND OTHER ACCESSORIES, PLEASE REFER TO *APPENDIX B*

SMX-3003 SWITCH MODULE

(4) 1 x 16 2-WIRE FIXED MULTIPLEXER

The SMX-3003 high-density multiplexer module consists of four individual (1 x 16) 2-wire multiplexers.

The SMX-3003 can be controlled programmatically using IviSwTch-compliant calls. Both path level programming and individual relay control are available. Refer to the host driver documentation for additional details. Figure 3-26 provides a logical diagram of the switch module and identifies the switches used by the module. This information can be used for individual relay control through the driver. An optional terminal block provides screw termination points for external field wiring. This terminal block also includes cold junction compensation reference for more precise temperature measurements.

CONNECTOR PINS AND SIGNALS

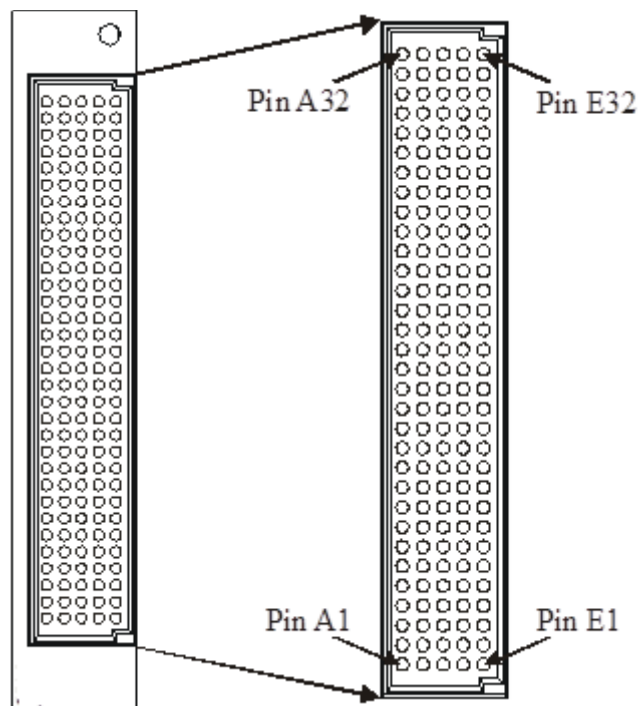

FIGURE 3-25: SMX-3003 FRONT PANEL CONNECTOR PINS (FRONT VIEW)

Row A		Row B		Row C		Row D		Row E	
Pin	Signal	Pin	Signal	Pin	Signal	Pin	Signal	Pin	Signal
1	UNUSED	1	UNUSED	1	CH1_1H	1	CH1_2H	1	CH1_3H
2	SHIELD	2	UNUSED	2	CH1_1L	2	CH1_2L	2	CH1_3L
3	CH1_4H	3	CH1_5H	3	CH1_6H	3	CH1_7H	3	CH1_8H
4	CH1_4L	4	CH1_5L	4	CH1_6L	4	CH1_7L	4	CH1_8L
5	UNUSED	5	CH1_COM H	5	CH1_9H	5	CH1_10H	5	CH1_11H
6	SHIELD	6	CH1_COM L	6	CH1_9L	6	CH1_10L	6	CH1_11L
7	CH1_12H	7	CH1_13H	7	CH1_14H	7	CH1_15H	7	CH1_16H
8	CH1_12L	8	CH1_13L	8	CH1_14L	8	CH1_15L	8	CH1_16L
9	UNUSED	9	UNUSED	9	CH2_1H	9	CH2_2H	9	CH2_3H
10	SHIELD	10	UNUSED	10	CH2_1L	10	CH2_2L	10	CH2_3L
11	CH2_4H	11	CH2_5H	11	CH2_6H	11	CH2_7H	11	CH2_8H
12	CH2_4L	12	CH2_5L	12	CH2_6L	12	CH2_7L	12	CH2_8L
13	UNUSED	13	CH2_COM H	13	CH2_9H	13	CH2_10H	13	CH2_11H
14	SHIELD	14	CH2_COM L	14	CH2_9L	14	CH2_10L	14	CH2_11L
15	CH2_12H	15	CH2_13H	15	CH2_14H	15	CH2_15H	15	CH2_16H
16	CH2_12L	16	CH2_13L	16	CH2_14L	16	CH2_15L	16	CH2_16L
17	UNUSED	17	UNUSED	17	CH3_1H	17	CH3_2H	17	CH3_3H
18	SHIELD	18	UNUSED	18	CH3_1L	18	CH3_2L	18	CH3_3L
19	CH3_4H	19	CH3_5H	19	CH3_6H	19	CH3_7H	19	CH3_8H
20	CH3_4L	20	CH3_5L	20	CH3_6L	20	CH3_7L	20	CH3_8L
21	UNUSED	21	CH3_COM H	21	CH3_9H	21	CH3_10H	21	CH3_11H
22	SHIELD	22	CH3_COM L	22	CH3_9L	22	CH3_10L	22	CH3_11L
23	CH3_12H	23	CH3_13H	23	CH3_14H	23	CH3_15H	23	CH3_16H
24	CH3_12L	24	CH3_13L	24	CH3_14L	24	CH3_15L	24	CH3_16L
25	UNUSED	25	CH4_COM H	25	CH4_1H	25	CH4_2H	25	CH4_3H
26	CH4_4H	26	CH4_COM L	26	CH4_1L	26	CH4_2L	26	CH4_3L
27	CH4_4L	27	CH4_5H	27	CH4_6H	27	CH4_7H	27	CH4_8H
28	UNUSED	28	CH4_5L	28	CH4_6L	28	CH4_7L	28	CH4_8L
29	UNUSED	29	CH4_9H	29	CH4_10H	29	CH4_11H	29	CH4_12H
30	UNUSED	30	CH4_9L	30	CH4_10L	30	CH4_11L	30	CH4_12L
31	CH4_13H	31	CH4_14H	31	CH4_15H	31	CH4_16H	31	SHIELD
32	CH4_13L	32	CH4_14L	32	CH4_15L	32	CH4_16L	32	UNUSED

TABLE 3-11: SMX-3003 PINS & SIGNAL ASSIGNMENTS

The SMX-3003 incorporates an integral shield into the design of the PCB that attenuates noise and crosstalk between adjacent channels/modules. To properly utilize this feature, tie the appropriate front panel connector pins to the mating cable's common shield and/or ground. These pins are identified as "SHIELD" in Table 3-11

LOGICAL DIAGRAM

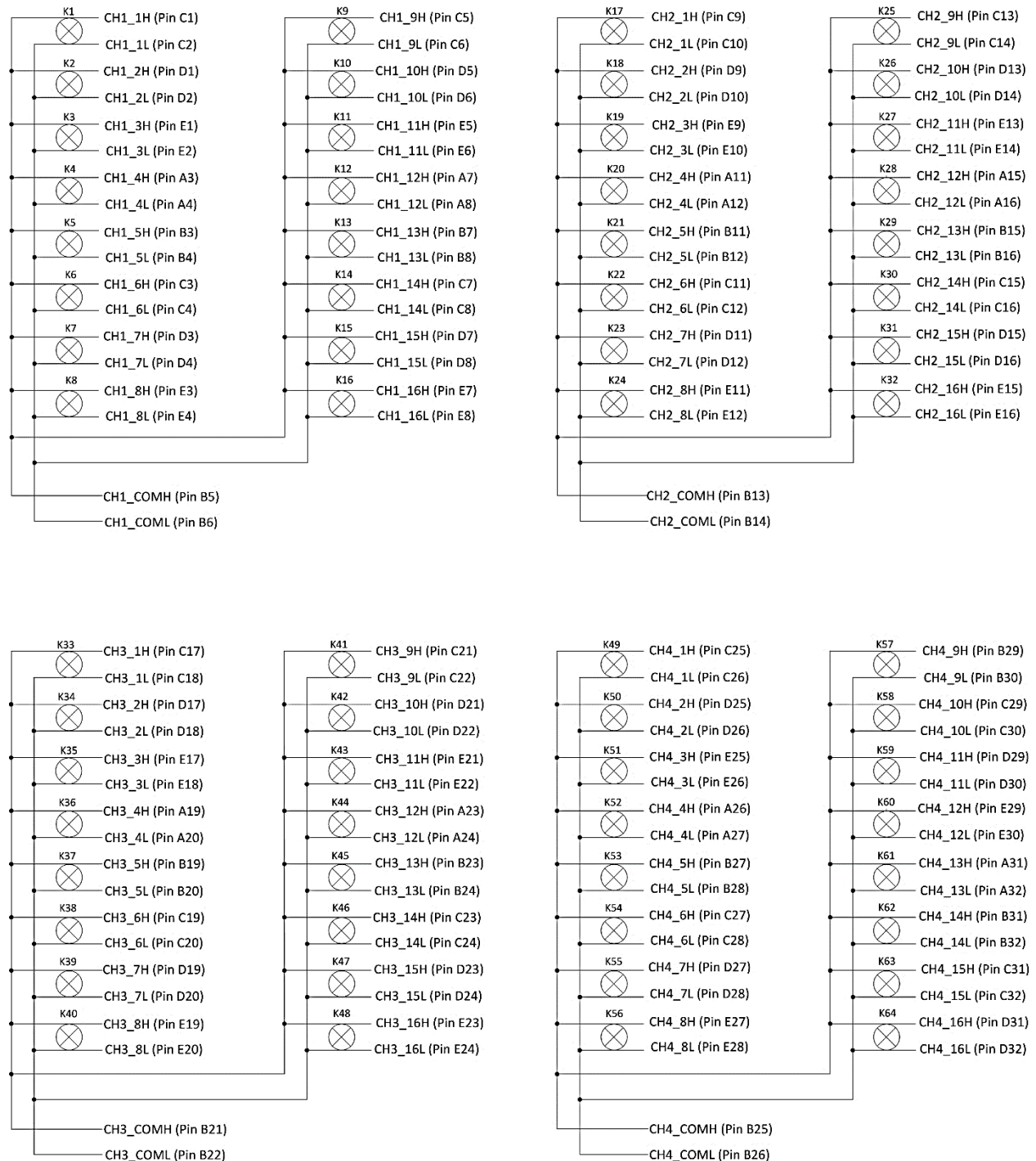

FIGURE 3-26: SMX-3003 LOGICAL DIAGRAM

SMX-3003 SPECIFICATIONS

GENERAL SPECIFICATIONS	
CHANNEL COUNT	(4) 1 x 16 2-wire Multiplexer
RELAY TYPE	Electromechanical, fail-safe
MAXIMUM SWITCHING VOLTAGE	300 V ac, 300 V dc
MAXIMUM SWITCHING CURRENT	2 A
MAXIMUM SWITCHING POWER	60 W dc, 62.5 VA
	<i>*Maximum switched power is at 30 V/ 2 A dc. Max switched power is derated non-linearly as voltage is increased.</i>
RATED SWITCH OPERATIONS	
Mechanical	1 x 10 ⁸ (no load)
Electrical	1 x 10 ⁵ @ (resistive load, 250VAC/0.25A), (resistive load, 30VDC/2A)
SWITCHING TIME	< 8 ms
PATH RESISTANCE	< 400mΩ
INSULATION RESISTANCE	> 1 x 10 ⁹ Ω
MAXIMUM THERMAL OFFSET PER CHANNEL (HI-LO)	
	< 10 μV
CAPACITANCE	
Open channel	< 14 pF
Channel-mainframe	< 180 pF
High-low	< 93 pF
BANDWIDTH (-3 dB)	
	92 MHz (typical), 97 MHz (best), 89 MHz (worst)
INSERTION LOSS	
100 kHz	< 0.07 dB
1 MHz	< 0.24 dB
10 MHz	< 0.36 dB
CROSSTALK	
100 kHz	< -71 dB
1 MHz	< -64 dB
ISOLATION	
100 kHz	< -62 dB
1 MHz	< -61 dB
10 MHz	< -29 dB

FOR MATING CONNECTOR, CRIMP PINS, AND OTHER ACCESSORIES, PLEASE REFER TO *APPENDIX B*

SMX-3003DS SWITCH MODULE

(4) 1 x 16 2-WIRE FIXED MULTIPLEXER

The SMX-3003DS high-density multiplexer module consists of four individual (1 x 16) 2-wire multiplexers.

In contrast to the SMX-3003 the SMX-3003DS has internal residual voltage discharge relays that can be enabled to momentarily short out the measurement path when changing from one input channel to the next. This dissipates any voltage held by the wiring and instrument input capacitance. These relays protect sensitive devices, such as CMOS circuits, from residual voltages caused by previous high-voltage measurements. This feature can also be disabled in low-voltage applications where maximum throughput speed is important.

The SMX-3003DS can be controlled programmatically using IviSwch-compliant calls. Both path level programming and individual relay control are available. Refer to the host driver documentation for additional details. Figure 3-28 provides a logical diagram of the switch module and identifies the switches used by the module. This information can be used for individual relay control through the driver. An optional terminal block provides screw termination points for external field wiring. This terminal block also includes cold junction compensation reference for more precise temperature measurements.

NOTE SMX-3003DS where DS stands for DISCHARGE relays support

CONNECTOR PINS AND SIGNALS

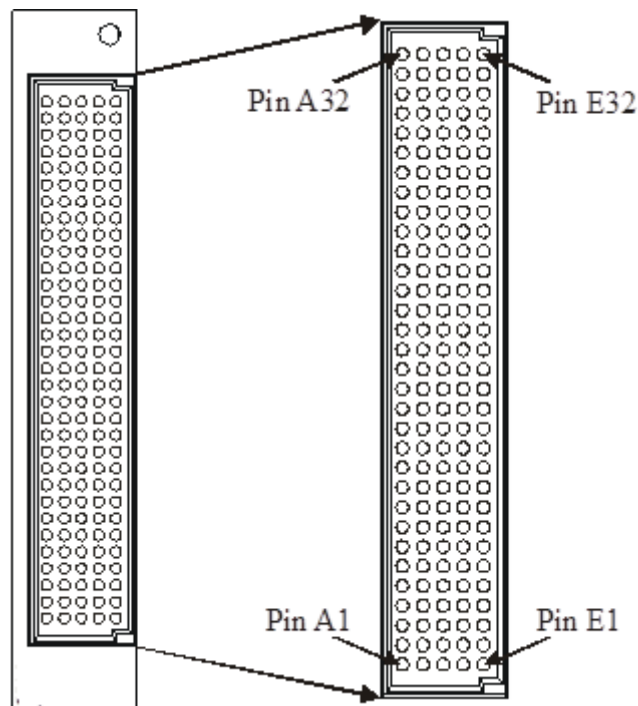

FIGURE 3-27: SMX-3003DS FRONT PANEL (FRONT VIEW)

Row A		Row B		Row C		Row D		Row E	
Pin	Signal	Pin	Signal	Pin	Signal	Pin	Signal	Pin	Signal
1	UNUSED	1	UNUSED	1	CH1_1H	1	CH1_2H	1	CH1_3H
2	SHIELD	2	UNUSED	2	CH1_1L	2	CH1_2L	2	CH1_3L
3	CH1_4H	3	CH1_5H	3	CH1_6H	3	CH1_7H	3	CH1_8H
4	CH1_4L	4	CH1_5L	4	CH1_6L	4	CH1_7L	4	CH1_8L
5	UNUSED	5	CH1_COM H	5	CH1_9H	5	CH1_10H	5	CH1_11H
6	SHIELD	6	CH1_COM L	6	CH1_9L	6	CH1_10L	6	CH1_11L
7	CH1_12H	7	CH1_13H	7	CH1_14H	7	CH1_15H	7	CH1_16H
8	CH1_12L	8	CH1_13L	8	CH1_14L	8	CH1_15L	8	CH1_16L
9	UNUSED	9	UNUSED	9	CH2_1H	9	CH2_2H	9	CH2_3H
10	SHIELD	10	UNUSED	10	CH2_1L	10	CH2_2L	10	CH2_3L
11	CH2_4H	11	CH2_5H	11	CH2_6H	11	CH2_7H	11	CH2_8H
12	CH2_4L	12	CH2_5L	12	CH2_6L	12	CH2_7L	12	CH2_8L
13	UNUSED	13	CH2_COM H	13	CH2_9H	13	CH2_10H	13	CH2_11H
14	SHIELD	14	CH2_COM L	14	CH2_9L	14	CH2_10L	14	CH2_11L
15	CH2_12H	15	CH2_13H	15	CH2_14H	15	CH2_15H	15	CH2_16H
16	CH2_12L	16	CH2_13L	16	CH2_14L	16	CH2_15L	16	CH2_16L
17	UNUSED	17	UNUSED	17	CH3_1H	17	CH3_2H	17	CH3_3H
18	SHIELD	18	UNUSED	18	CH3_1L	18	CH3_2L	18	CH3_3L
19	CH3_4H	19	CH3_5H	19	CH3_6H	19	CH3_7H	19	CH3_8H
20	CH3_4L	20	CH3_5L	20	CH3_6L	20	CH3_7L	20	CH3_8L
21	UNUSED	21	CH3_COM H	21	CH3_9H	21	CH3_10H	21	CH3_11H
22	SHIELD	22	CH3_COM L	22	CH3_9L	22	CH3_10L	22	CH3_11L
23	CH3_12H	23	CH3_13H	23	CH3_14H	23	CH3_15H	23	CH3_16H
24	CH3_12L	24	CH3_13L	24	CH3_14L	24	CH3_15L	24	CH3_16L
25	UNUSED	25	CH4_COM H	25	CH4_1H	25	CH4_2H	25	CH4_3H
26	CH4_4H	26	CH4_COM L	26	CH4_1L	26	CH4_2L	26	CH4_3L
27	CH4_4L	27	CH4_5H	27	CH4_6H	27	CH4_7H	27	CH4_8H
28	UNUSED	28	CH4_5L	28	CH4_6L	28	CH4_7L	28	CH4_8L
29	UNUSED	29	CH4_9H	29	CH4_10H	29	CH4_11H	29	CH4_12H
30	UNUSED	30	CH4_9L	30	CH4_10L	30	CH4_11L	30	CH4_12L
31	CH4_13H	31	CH4_14H	31	CH4_15H	31	CH4_16H	31	SHIELD
32	CH4_13L	32	CH4_14L	32	CH4_15L	32	CH4_16L	32	UNUSED

TABLE 3-12: SMX-3003DS CONNECTOR PINS & SIGNAL ASSIGNMENTS

The SMX-3003DS incorporates an integral shield into the design of the PCB that attenuates noise and crosstalk between adjacent channels/modules. To properly utilize this feature, tie the appropriate front panel connector pins to the mating cable's common shield and/or ground. These pins are identified as "SHIELD" in Table 3-12

LOGICAL DIAGRAM

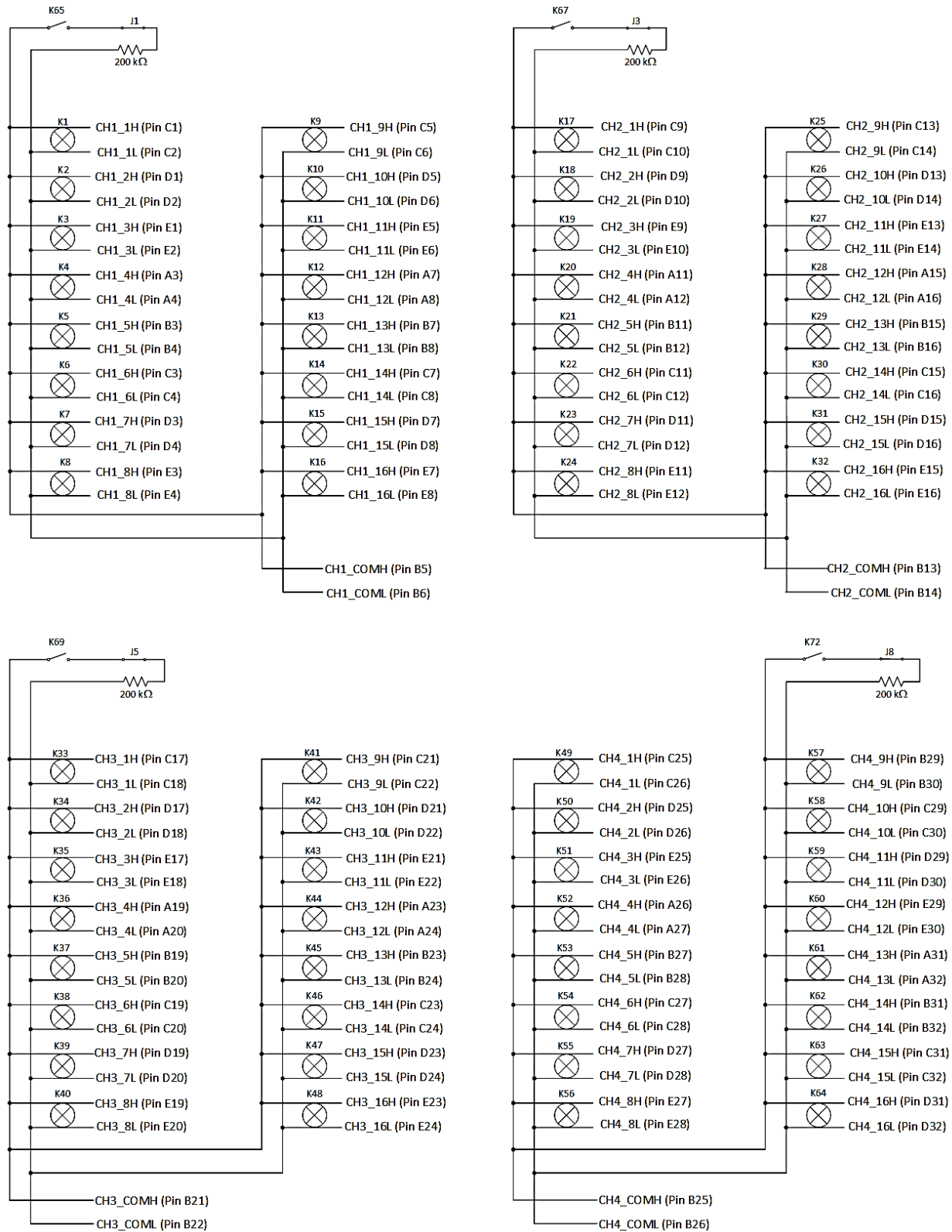

FIGURE 3-28: SMX-3003DS LOGICAL DIAGRAM

SMX-3003DS SPECIFICATIONS

GENERAL SPECIFICATIONS	
CHANNEL COUNT	(4) 1 x 16 2-wire Multiplexer
RELAY TYPE	Electromechanical, fail-safe
MAXIMUM SWITCHING VOLTAGE	300 V ac, 300 V dc
MAXIMUM SWITCHING CURRENT	2 A
MAXIMUM SWITCHING POWER	60 W dc, 62.5 VA
	<i>*Maximum switched power is at 30 V/ 2 A dc. Max switched power is derated non-linearly as voltage is increased.</i>
RATED SWITCH OPERATIONS	
Mechanical	1 x 10 ⁸ (no load)
Electrical	1 x 10 ⁵ @ (resistive load, 250VAC/0.25A), (resistive load, 30VDC/2A)
SWITCHING TIME	< 8 ms
PATH RESISTANCE	< 400mΩ
INSULATION RESISTANCE	> 1 x 10 ⁹ Ω
MAXIMUM THERMAL OFFSET PER CHANNEL (HI-LO)	
	< 10 μV
CAPACITANCE	
Open channel	< 14 pF
Channel-mainframe	< 180 pF
High-low	< 93 pF
BANDWIDTH (-3 dB)	
	92 MHz (typical), 97 MHz (best), 89 MHz (worst)
INSERTION LOSS	
100 kHz	< 0.07 dB
1 MHz	< 0.24 dB
10 MHz	< 0.36 dB
CROSSTALK	
100 kHz	< -71 dB
1 MHz	< -64 dB
ISOLATION	
100 kHz	< -62 dB
1 MHz	< -61 dB
10 MHz	< -29 dB

FOR MATING CONNECTOR, CRIMP PINS, AND OTHER ACCESSORIES, PLEASE REFER TO *APPENDIX B*

SMX-3004 SWITCH MODULE

(2) 1 x 32 2-WIRE FIXED MULTIPLEXER

The SMX-3004 high-density multiplexer module consists of two individual (1 x 32) 2-wire multiplexers.

The SMX-3004 can be controlled programmatically using IviSwtch-compliant calls. Both path level programming and individual relay control are available. Refer to the host driver documentation for additional details. Figure 3-30 provides a logical diagram of the switch module and identifies the switches used by the module. This information can be used for individual relay control through the driver. An optional terminal block provides screw termination points for external field wiring. This terminal block also includes cold junction compensation reference for more precise temperature measurements.

CONNECTOR PINS AND SIGNALS

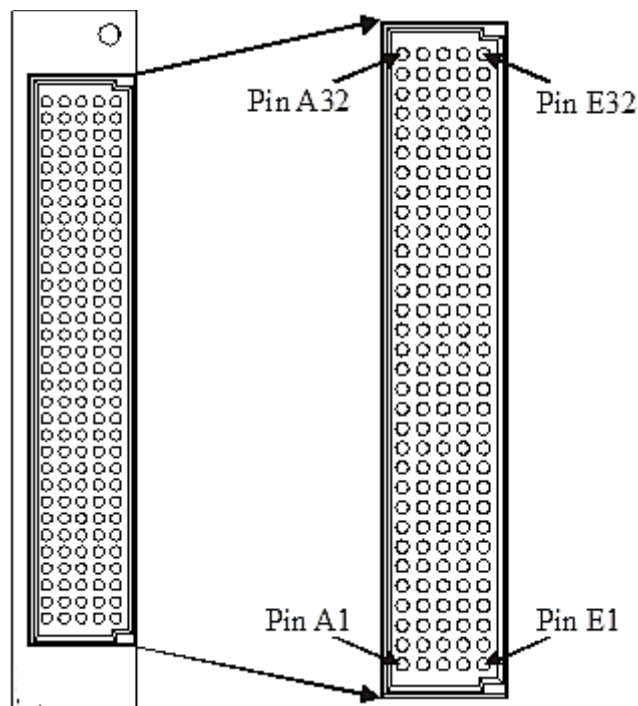

FIGURE 3-29: SMX-3004 FRONT PANEL CONNECTOR PINS (FRONT VIEW)

Row A		Row B		Row C		Row D		Row E	
Pin	Signal	Pin	Signal	Pin	Signal	Pin	Signal	Pin	Signal
1	UNUSED	1	UNUSED	1	CH1_1H	1	CH1_2H	1	CH1_3H
2	SHIELD	2	UNUSED	2	CH1_1L	2	CH1_2L	2	CH1_3L
3	CH1_4H	3	CH1_5H	3	CH1_6H	3	CH1_7H	3	CH1_8H
4	CH1_4L	4	CH1_5L	4	CH1_6L	4	CH1_7L	4	CH1_8L
5	UNUSED	5	CH1_COM H	5	CH1_9H	5	CH1_10H	5	CH1_11H
6	SHIELD	6	CH1_COM L	6	CH1_9L	6	CH1_10L	6	CH1_11L
7	CH1_12H	7	CH1_13H	7	CH1_14H	7	CH1_15H	7	CH1_16H
8	CH1_12L	8	CH1_13L	8	CH1_14L	8	CH1_15L	8	CH1_16L
9	UNUSED	9	UNUSED	9	CH1_17H	9	CH1_18H	9	CH1_19H
10	SHIELD	10	UNUSED	10	CH1_17L	10	CH1_18L	10	CH1_19L
11	CH1_20H	11	CH1_21H	11	CH1_22H	11	CH1_23H	11	CH1_24H
12	CH1_20L	12	CH1_21L	12	CH1_22L	12	CH1_23L	12	CH1_24L
13	UNUSED	13	UNUSED	13	CH1_25H	13	CH1_26H	13	CH1_27H
14	SHIELD	14	UNUSED	14	CH1_25L	14	CH1_26L	14	CH1_27L
15	CH1_28H	15	CH1_29H	15	CH1_30H	15	CH1_31H	15	CH1_32H
16	CH1_28L	16	CH1_29L	16	CH1_30L	16	CH1_31L	16	CH1_32L
17	UNUSED	17	UNUSED	17	CH2_1H	17	CH2_2H	17	CH2_3H
18	SHIELD	18	UNUSED	18	CH2_1L	18	CH2_2L	18	CH2_3L
19	CH2_4H	19	CH2_5H	19	CH2_6H	19	CH2_7H	19	CH2_8H
20	CH2_4L	20	CH2_5L	20	CH2_6L	20	CH2_7L	20	CH2_8L
21	UNUSED	21	CH2_COM H	21	CH2_9H	21	CH2_10H	21	CH2_11H
22	SHIELD	22	CH2_COM L	22	CH2_9L	22	CH2_10L	22	CH2_11L
23	CH2_12H	23	CH2_13H	23	CH2_14H	23	CH2_15H	23	CH2_16H
24	CH2_12L	24	CH2_13L	24	CH2_14L	24	CH2_15L	24	CH2_16L
25	UNUSED	25	UNUSED	25	CH2_17H	25	CH2_18H	25	CH2_19H
26	CH2_20H	26	UNUSED	26	CH2_17L	26	CH2_18L	26	CH2_19L
27	CH2_20L	27	CH2_21H	27	CH2_22H	27	CH2_23H	27	CH2_24H
28	UNUSED	28	CH2_21L	28	CH2_22L	28	CH2_23L	28	CH2_24L
29	UNUSED	29	CH2_25H	29	CH2_26H	29	CH2_27H	29	CH2_28H
30	UNUSED	30	CH2_25L	30	CH2_26L	30	CH2_27L	30	CH2_28L
31	CH2_29H	31	CH2_30H	31	CH2_31H	31	CH2_32H	31	SHIELD
32	CH2_29L	32	CH2_30L	32	CH2_31L	32	CH2_32L	32	UNUSED

TABLE 3-13: SMX-3004 PINS & SIGNAL ASSIGNMENTS

The SMX-3004 incorporates an integral shield into the design of the PCB that attenuates noise and crosstalk between adjacent channels/modules. To properly utilize this feature, tie the appropriate front panel connector pins to the mating cable's common shield and/or ground. These pins are identified as "SHIELD" in Table 3-13

LOGICAL DIAGRAM

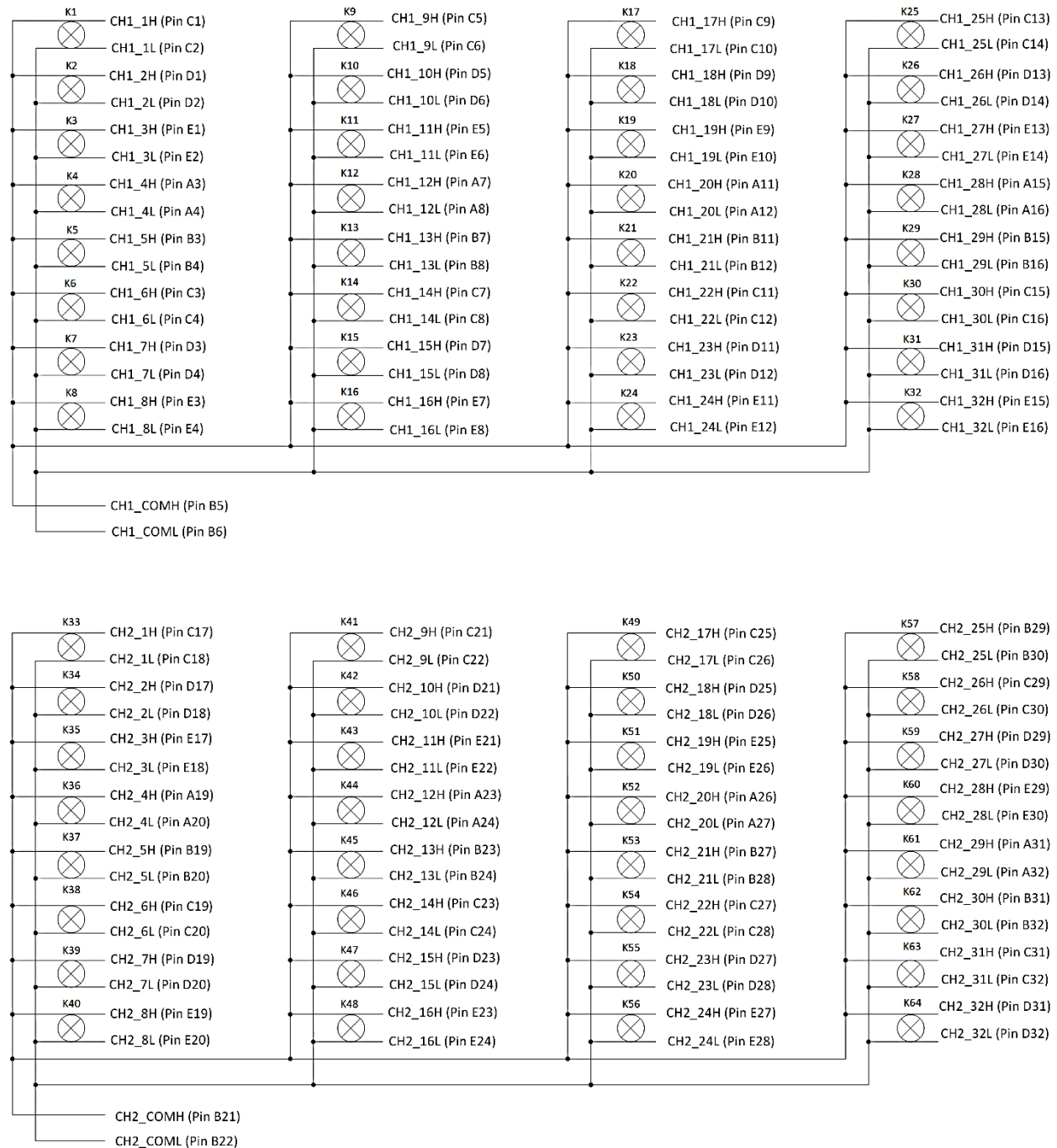

FIGURE 3-30: SMX-3004 LOGICAL DIAGRAM

SMX-3004 SPECIFICATIONS

GENERAL SPECIFICATIONS	
CHANNEL COUNT	(2) 1 x 32 2-wire Multiplexer
RELAY TYPE	Electromechanical, fail-safe
MAXIMUM SWITCHING VOLTAGE	300 V ac, 300 V dc
MAXIMUM SWITCHING CURRENT	2 A
MAXIMUM SWITCHING POWER	60 W dc, 62.5 VA
<i>*Maximum switched power is at 30 V/ 2 A dc. Max switched power is derated non-linearly as voltage is increased.</i>	
RATED SWITCH OPERATIONS	
Mechanical	1 x 10 ⁸ (no load)
Electrical	Min. 1 x 10 ⁵ @ (resistive load, 250VAC/0.25A), (resistive load, 30VDC/2A)
SWITCHING TIME	< 8 ms
PATH RESISTANCE	< 400 mΩ
INSULATION RESISTANCE	> 1 x 10 ⁹ Ω
MAXIMUM THERMAL OFFSET PER CHANNEL (HI-LO)	< 10 μV
CAPACITANCE	
Open channel	< 14 pF
Channel-mainframe	< 360 pF
High-low	< 175 pF
BANDWIDTH (-3 dB)	46 MHz (typical), 49 MHz (best), 45 MHz (worst)
INSERTION LOSS	
100 kHz	< 0.08 dB
1 MHz	< 0.09 dB
10 MHz	< 0.09 dB
CROSSTALK	
100 kHz	< -66 dB
1 MHz	< -51 dB
ISOLATION	
100 kHz	< -62 dB
1 MHz	< -54 dB

FOR MATING CONNECTOR, CRIMP PINS, AND OTHER ACCESSORIES, PLEASE REFER TO *APPENDIX B*

SMX-3004DS SWITCH MODULE

(2) 1 x 32 2-WIRE FIXED MULTIPLEXER

The SMX-3003DS high-density multiplexer module consists of two individual (1 x 32) 2-wire multiplexers.

In contrast to the SMX-3004 the SMX-3004DS has internal residual voltage discharge relays that can be enabled to momentarily short out the measurement path when changing from one input channel to the next. This dissipates any voltage held by the wiring and instrument input capacitance. These relays protect sensitive devices, such as CMOS circuits, from residual voltages caused by previous high-voltage measurements. This feature can also be disabled in low-voltage applications where maximum throughput speed is important.

The SMX-3004DS can be controlled programmatically using IviSwch-compliant calls. Both path level programming and individual relay control are available. Refer to the host driver documentation for additional details. Figure 3-32 provides a logical diagram of the switch module and identifies the switches used by the module. This information can be used for individual relay control through the driver. An optional terminal block provides screw termination points for external field wiring. This terminal block also includes cold junction compensation reference for more precise temperature measurements.

NOTE SMX-3004DS where DS stands for DISCHARGE relays support

CONNECTOR PINS AND SIGNALS

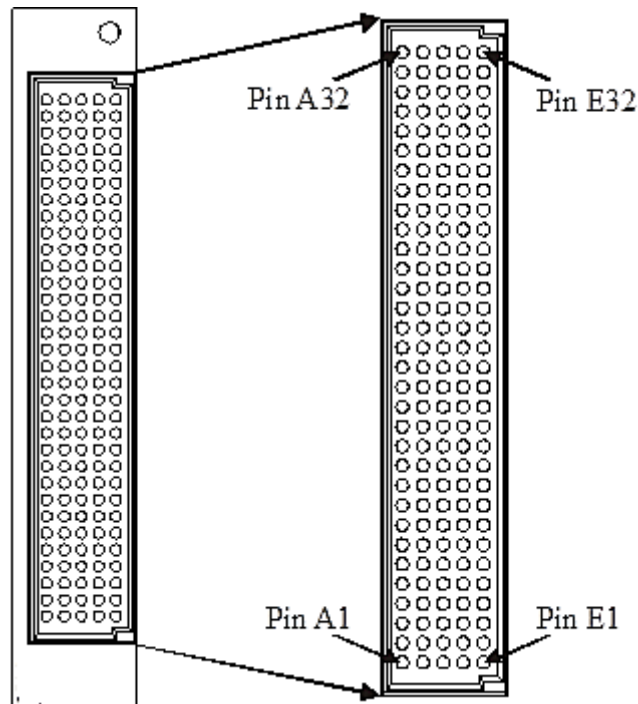

FIGURE 3-31: SMX-3004DS FRONT PANEL (FRONT VIEW)

Row A		Row B		Row C		Row D		Row E	
Pin	Signal	Pin	Signal	Pin	Signal	Pin	Signal	Pin	Signal
1	UNUSED	1	UNUSED	1	CH1_1H	1	CH1_2H	1	CH1_3H
2	SHIELD	2	UNUSED	2	CH1_1L	2	CH1_2L	2	CH1_3L
3	CH1_4H	3	CH1_5H	3	CH1_6H	3	CH1_7H	3	CH1_8H
4	CH1_4L	4	CH1_5L	4	CH1_6L	4	CH1_7L	4	CH1_8L
5	UNUSED	5	CH1_COM H	5	CH1_9H	5	CH1_10H	5	CH1_11H
6	SHIELD	6	CH1_COM L	6	CH1_9L	6	CH1_10L	6	CH1_11L
7	CH1_12H	7	CH1_13H	7	CH1_14H	7	CH1_15H	7	CH1_16H
8	CH1_12L	8	CH1_13L	8	CH1_14L	8	CH1_15L	8	CH1_16L
9	UNUSED	9	UNUSED	9	CH1_17H	9	CH1_18H	9	CH1_19H
10	SHIELD	10	UNUSED	10	CH1_17L	10	CH1_18L	10	CH1_19L
11	CH1_20H	11	CH1_21H	11	CH1_22H	11	CH1_23H	11	CH1_24H
12	CH1_20L	12	CH1_21L	12	CH1_22L	12	CH1_23L	12	CH1_24L
13	UNUSED	13	UNUSED	13	CH1_25H	13	CH1_26H	13	CH1_27H
14	SHIELD	14	UNUSED	14	CH1_25L	14	CH1_26L	14	CH1_27L
15	CH1_28H	15	CH1_29H	15	CH1_30H	15	CH1_31H	15	CH1_32H
16	CH1_28L	16	CH1_29L	16	CH1_30L	16	CH1_31L	16	CH1_32L
17	UNUSED	17	UNUSED	17	CH2_1H	17	CH2_2H	17	CH2_3H
18	SHIELD	18	UNUSED	18	CH2_1L	18	CH2_2L	18	CH2_3L
19	CH2_4H	19	CH2_5H	19	CH2_6H	19	CH2_7H	19	CH2_8H
20	CH2_4L	20	CH2_5L	20	CH2_6L	20	CH2_7L	20	CH2_8L
21	UNUSED	21	CH2_COM H	21	CH2_9H	21	CH2_10H	21	CH2_11H
22	SHIELD	22	CH2_COM L	22	CH2_9L	22	CH2_10L	22	CH2_11L
23	CH2_12H	23	CH2_13H	23	CH2_14H	23	CH2_15H	23	CH2_16H
24	CH2_12L	24	CH2_13L	24	CH2_14L	24	CH2_15L	24	CH2_16L
25	UNUSED	25	UNUSED	25	CH2_17H	25	CH2_18H	25	CH2_19H
26	CH2_20H	26	UNUSED	26	CH2_17L	26	CH2_18L	26	CH2_19L
27	CH2_20L	27	CH2_21H	27	CH2_22H	27	CH2_23H	27	CH2_24H
28	UNUSED	28	CH2_21L	28	CH2_22L	28	CH2_23L	28	CH2_24L
29	UNUSED	29	CH2_25H	29	CH2_26H	29	CH2_27H	29	CH2_28H
30	UNUSED	30	CH2_25L	30	CH2_26L	30	CH2_27L	30	CH2_28L
31	CH2_29H	31	CH2_30H	31	CH2_31H	31	CH2_32H	31	SHIELD
32	CH2_29L	32	CH2_30L	32	CH2_31L	32	CH2_32L	32	UNUSED

TABLE 3-14: SMX-3004DS CONNECTOR PINS & SIGNAL ASSIGNMENTS

The SMX-3004DS incorporates an integral shield into the design of the PCB that attenuates noise and crosstalk between adjacent channels/modules. To properly utilize this feature, tie the appropriate front panel connector pins to the mating cable's common shield and/or ground. These pins are identified as "SHIELD" in Table 3-14

LOGICAL DIAGRAM

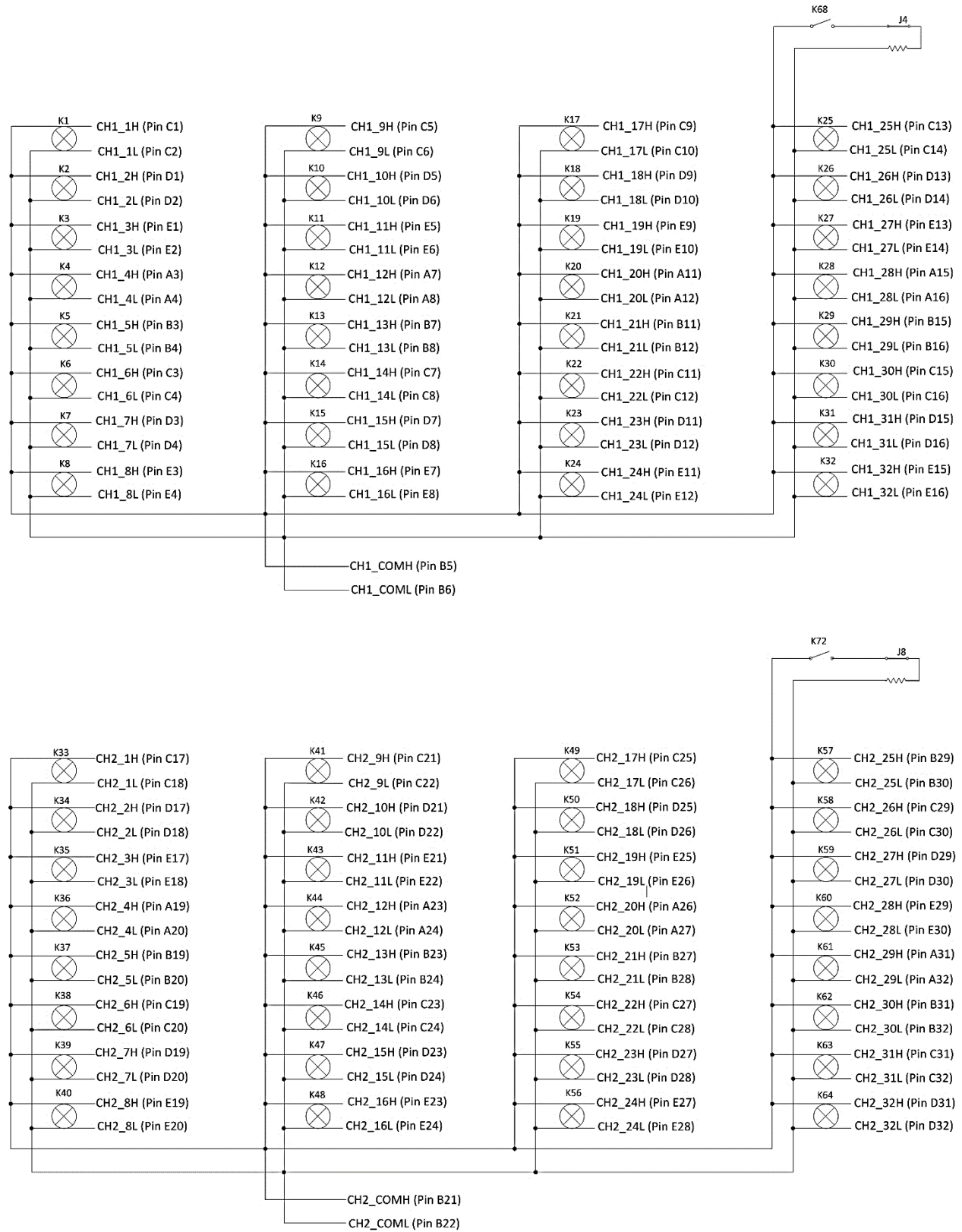

FIGURE 3-32: SMX-3004DS LOGICAL DIAGRAM

SMX-3004DS SPECIFICATIONS

GENERAL SPECIFICATIONS	
CHANNEL COUNT	(2) 1 x 32 2-wire Multiplexer
RELAY TYPE	Electromechanical, fail-safe
MAXIMUM SWITCHING VOLTAGE	300 V ac, 300 V dc
MAXIMUM SWITCHING CURRENT	2 A
MAXIMUM SWITCHING POWER	60 W dc, 62.5 VA
	<i>*Maximum switched power is at 30 V/ 2 A dc. Max switched power is derated non-linearly as voltage is increased.</i>
RATED SWITCH OPERATIONS	
Mechanical	1 x 10 ⁸ (no load)
Electrical	Min. 1 x 10 ⁵ @ (resistive load, 250VAC/0.25A), (resistive load, 30VDC/2A)
SWITCHING TIME	< 8 ms
PATH RESISTANCE	< 400 mΩ
INSULATION RESISTANCE	> 1 x 10 ⁹ Ω
MAXIMUM THERMAL OFFSET PER CHANNEL (HI-LO)	
	< 10 μV
CAPACITANCE	
Open channel	< 14 pF
Channel-mainframe	< 360 pF
High-low	< 175 pF
BANDWIDTH (-3 dB)	
	46 MHz (typical), 49 MHz (best), 45 MHz (worst)
INSERTION LOSS	
100 kHz	< 0.08 dB
1 MHz	< 0.09 dB
10 MHz	< 0.09 dB
CROSSTALK	
100 kHz	< -66 dB
1 MHz	< -51 dB
ISOLATION	
100 kHz	< -62 dB
1 MHz	< -54 dB

FOR MATING CONNECTOR, CRIMP PINS, AND OTHER ACCESSORIES, PLEASE REFER TO *APPENDIX B*

SMX-3005 SWITCH MODULE

(1) 1 X 64 2-WIRE FIXED MULTIPLEXER

The SMX-3005 high-density multiplexer module consists of one (1 x 64) 2-wire multiplexer.

The SMX-3005 can be controlled programmatically using IviSwTch-compliant calls. Both path level programming and individual relay control are available. Refer to the host driver documentation for additional details.

Figure 3-34 provides a logical diagram of the switch module and identifies the switches used by the module. This information can be used for individual relay control through the driver. An optional terminal block provides screw termination points for external field wiring. This terminal block also includes cold junction compensation reference for more precise temperature measurements.

CONNECTOR PINS AND SIGNALS

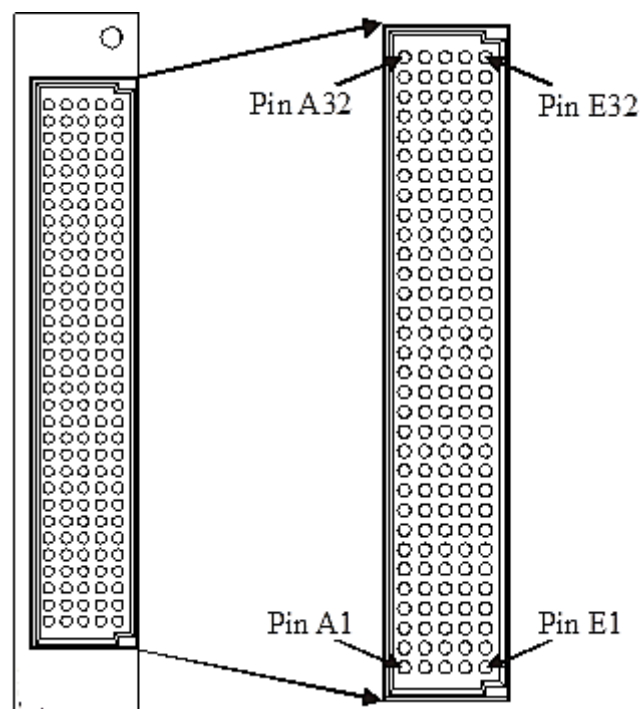

FIGURE 3-33: SMX-3005 FRONT PANEL CONNECTOR PINS (FRONT VIEW)

Row A		Row B		Row C		Row D		Row E	
Pin	Signal	Pin	Signal	Pin	Signal	Pin	Signal	Pin	Signal
1	UNUSED	1	UNUSED	1	CH_1H	1	CH_2H	1	CH_3H
2	SHIELD	2	UNUSED	2	CH_1L	2	CH_2L	2	CH_3L
3	CH_4H	3	CH_5H	3	CH_6H	3	CH_7H	3	CH_8H
4	CH_4L	4	CH_5L	4	CH_6L	4	CH_7L	4	CH_8L
5	UNUSED	5	UNUSED	5	CH_9H	5	CH_10H	5	CH_11H
6	SHIELD	6	UNUSED	6	CH_9L	6	CH_10L	6	CH_11L
7	CH_12H	7	CH_13H	7	CH_14H	7	CH_15H	7	CH_16H
8	CH_12L	8	CH_13L	8	CH_14L	8	CH_15L	8	CH_16L
9	UNUSED	9	UNUSED	9	CH_17H	9	CH_18H	9	CH_19H
10	SHIELD	10	UNUSED	10	CH_17L	10	CH_18L	10	CH_19L
11	CH_20H	11	CH_21H	11	CH_22H	11	CH_23H	11	CH_24H
12	CH_20L	12	CH_21L	12	CH_22L	12	CH_23L	12	CH_24L
13	UNUSED	13	UNUSED	13	CH_25H	13	CH_26H	13	CH_27H
14	SHIELD	14	UNUSED	14	CH_25L	14	CH_26L	14	CH_27L
15	CH_28H	15	CH_29H	15	CH_30H	15	CH_31H	15	CH_32H
16	CH_28L	16	CH_29L	16	CH_30L	16	CH_31L	16	CH_32L
17	UNUSED	17	UNUSED	17	CH_33H	17	CH_34H	17	CH_35H
18	SHIELD	18	UNUSED	18	CH_33L	18	CH_34L	18	CH_35L
19	CH_36H	19	CH_37H	19	CH_38H	19	CH_39H	19	CH_40H
20	CH_36L	20	CH_37L	20	CH_38L	20	CH_39L	20	CH_40L
21	UNUSED	21	CH_COMH	21	CH_41H	21	CH_42H	21	CH_43H
22	SHIELD	22	CH_COML	22	CH_41L	22	CH_42L	22	CH_43L
23	CH_44H	23	CH_45H	23	CH_46H	23	CH_47H	23	CH_48H
24	CH_44L	24	CH_45L	24	CH_46L	24	CH_47L	24	CH_48L
25	UNUSED	25	UNUSED	25	CH_49H	25	CH_50H	25	CH_51H
26	CH_52H	26	UNUSED	26	CH_49L	26	CH_50L	26	CH_51L
27	CH_52L	27	CH_53H	27	CH_54H	27	CH_55H	27	CH_56H
28	UNUSED	28	CH_53L	28	CH_54L	28	CH_55L	28	CH_56L
29	UNUSED	29	CH_57H	29	CH_58H	29	CH_59H	29	CH_60H
30	UNUSED	30	CH_57L	30	CH_58L	30	CH_59L	30	CH_60L
31	CH_61H	31	CH_62H	31	CH_63H	31	CH_64H	31	SHIELD
32	CH_61L	32	CH_62L	32	CH_63L	32	CH_64L	32	UNUSED

TABLE 3-15: SMX-3005 PINS & SIGNAL ASSIGNMENTS

The SMX-3005 incorporates an integral shield into the design of the PCB that attenuates noise and crosstalk between adjacent channels/modules. To properly utilize this feature, tie the appropriate front panel connector pins to the mating cable's common shield and/or ground. These pins are identified as "SHIELD" in Table 3-15

LOGICAL DIAGRAM

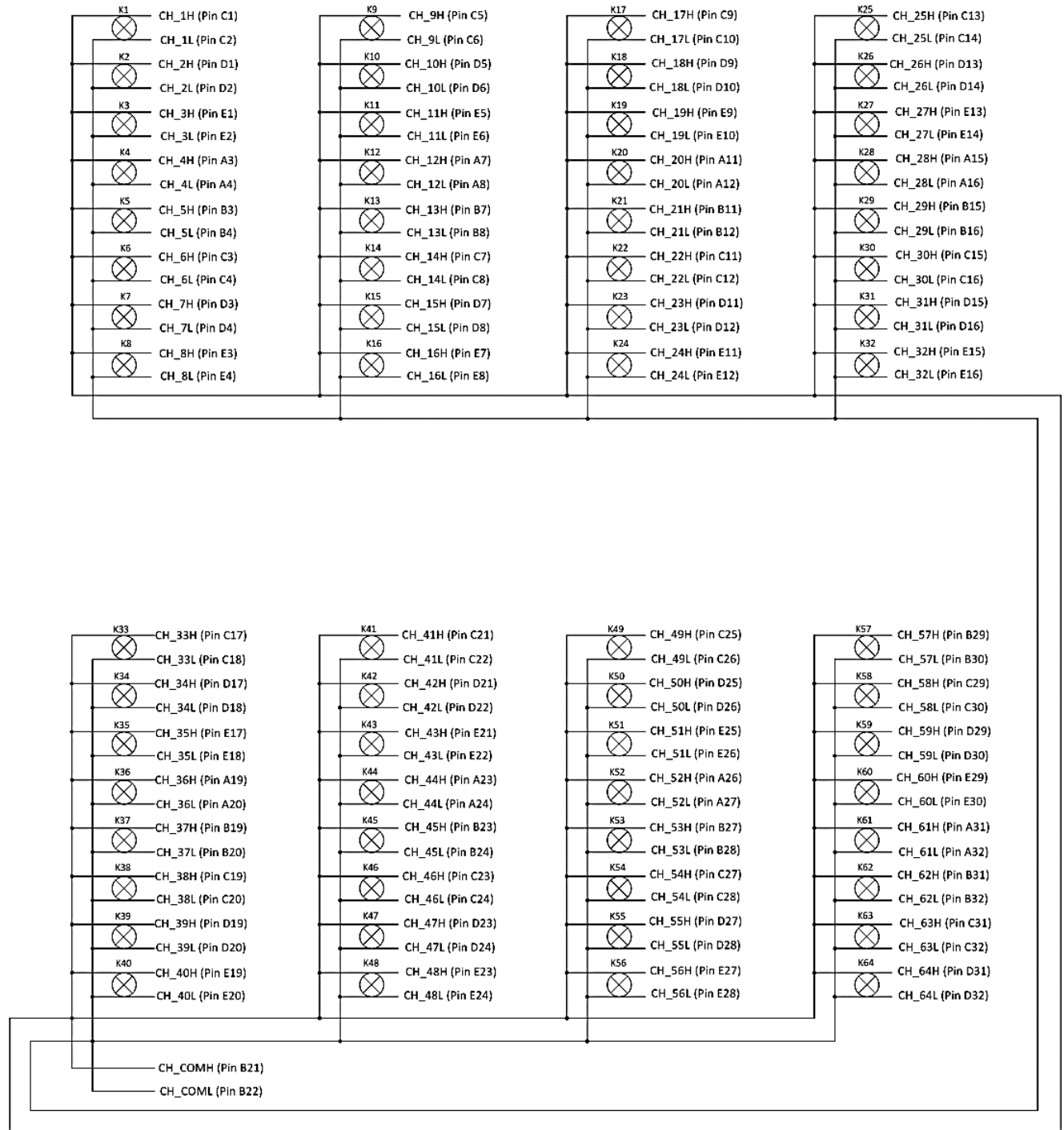

FIGURE 3-34: SMX-3005 LOGICAL DIAGRAM

SMX-3005 SPECIFICATIONS

GENERAL SPECIFICATIONS	
CHANNEL COUNT	(1) 1 x 64 2-wire Multiplexer
RELAY TYPE	Electromechanical, fail-safe
MAXIMUM SWITCHING VOLTAGE	300 V ac, 300 V dc
MAXIMUM SWITCHING CURRENT	2 A
MAXIMUM SWITCHING POWER	60 W dc, 62.5 VA
	<i>*Maximum switched power is at 30 V/ 2 A dc. Max switched power is derated non-linearly as voltage is increased.</i>
RATED SWITCH OPERATIONS	
Mechanical	1 x 10 ⁸ (no load)
Electrical	Min. 1 x 10 ⁵ @ (resistive load, 250VAC/0.25A), (resistive load, 30VDC/2A)
SWITCHING TIME	< 8 ms
PATH RESISTANCE	< 400 mΩ
INSULATION RESISTANCE	> 1 x 10 ⁹ Ω
MAXIMUM THERMAL OFFSET PER CHANNEL (HI-LO)	
	< 10 μV
CAPACITANCE	
Open channel	< 14 pF
Channel-mainframe	< 553 pF
High-low	< 349 pF
BANDWIDTH (-3 dB)	
	26 MHz (typical), 26 MHz (best), 25 MHz (worst)
INSERTION LOSS	
100 kHz	< 0.45 dB
1 MHz	< 0.46 dB
10 MHz	< 0.93 dB
CROSSTALK	
100 kHz	< -71 dB
1 MHz	< -53 dB
ISOLATION	
100 kHz	< -62 dB
1 MHz	< -55 dB

FOR MATING CONNECTOR, CRIMP PINS, AND OTHER ACCESSORIES, PLEASE REFER TO *APPENDIX B*

SMX-3005DS SWITCH MODULE

(1) 1 x 64 2-WIRE FIXED MULTIPLEXER

The SMX-3005DS high-density multiplexer module consists of one (1 x 64) 2-wire multiplexer.

In contrast to the SMX-3005 the SMX-3005DS has internal residual voltage discharge relays that can be enabled to momentarily short out the measurement path when changing from one input channel to the next. This dissipates any voltage held by the wiring and instrument input capacitance. These relays protect sensitive devices, such as CMOS circuits, from residual voltages caused by previous high-voltage measurements. This feature can also be disabled in low-voltage applications where maximum throughput speed is important.

The SMX-3005DS can be controlled programmatically using IviSwch-compliant calls. Both path level programming and individual relay control are available. Refer to the host driver documentation for additional details.

Figure 3-36 provides a logical diagram of the switch module and identifies the switches used by the module. This information can be used for individual relay control through the driver. An optional terminal block provides screw termination points for external field wiring. This terminal block also includes cold junction compensation reference for more precise temperature measurements.

NOTE SMX-3005DS where DS stands for DISCHARGE relays support

CONNECTOR PINS AND SIGNALS

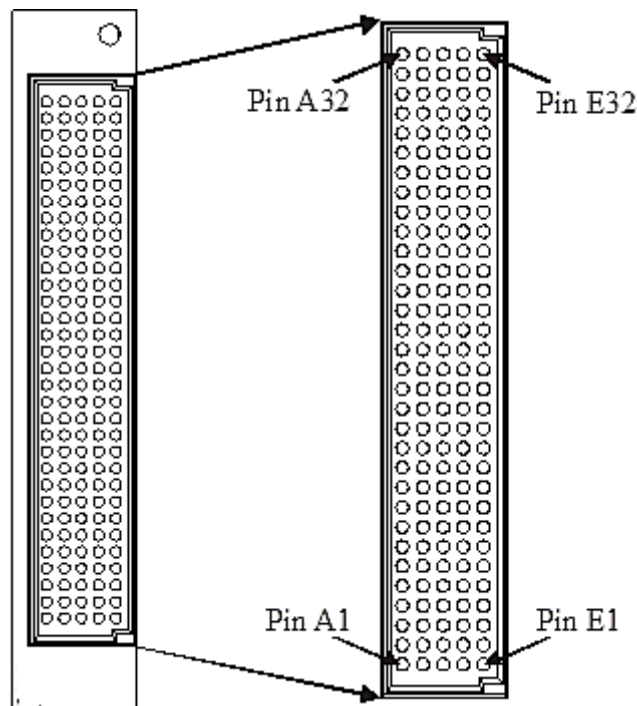

FIGURE 3-35: SMX-3005DS FRONT PANEL (FRONT VIEW)

Row A		Row B		Row C		Row D		Row E	
Pin	Signal	Pin	Signal	Pin	Signal	Pin	Signal	Pin	Signal
1	UNUSED	1	UNUSED	1	CH_1H	1	CH_2H	1	CH_3H
2	SHIELD	2	UNUSED	2	CH_1L	2	CH_2L	2	CH_3L
3	CH_4H	3	CH_5H	3	CH_6H	3	CH_7H	3	CH_8H
4	CH_4L	4	CH_5L	4	CH_6L	4	CH_7L	4	CH_8L
5	UNUSED	5	UNUSED	5	CH_9H	5	CH_10H	5	CH_11H
6	SHIELD	6	UNUSED	6	CH_9L	6	CH_10L	6	CH_11L
7	CH_12H	7	CH_13H	7	CH_14H	7	CH_15H	7	CH_16H
8	CH_12L	8	CH_13L	8	CH_14L	8	CH_15L	8	CH_16L
9	UNUSED	9	UNUSED	9	CH_17H	9	CH_18H	9	CH_19H
10	SHIELD	10	UNUSED	10	CH_17L	10	CH_18L	10	CH_19L
11	CH_20H	11	CH_21H	11	CH_22H	11	CH_23H	11	CH_24H
12	CH_20L	12	CH_21L	12	CH_22L	12	CH_23L	12	CH_24L
13	UNUSED	13	UNUSED	13	CH_25H	13	CH_26H	13	CH_27H
14	SHIELD	14	UNUSED	14	CH_25L	14	CH_26L	14	CH_27L
15	CH_28H	15	CH_29H	15	CH_30H	15	CH_31H	15	CH_32H
16	CH_28L	16	CH_29L	16	CH_30L	16	CH_31L	16	CH_32L
17	UNUSED	17	UNUSED	17	CH_33H	17	CH_34H	17	CH_35H
18	SHIELD	18	UNUSED	18	CH_33L	18	CH_34L	18	CH_35L
19	CH_36H	19	CH_37H	19	CH_38H	19	CH_39H	19	CH_40H
20	CH_36L	20	CH_37L	20	CH_38L	20	CH_39L	20	CH_40L
21	UNUSED	21	CH_COMH	21	CH_41H	21	CH_42H	21	CH_43H
22	SHIELD	22	CH_COML	22	CH_41L	22	CH_42L	22	CH_43L
23	CH_44H	23	CH_45H	23	CH_46H	23	CH_47H	23	CH_48H
24	CH_44L	24	CH_45L	24	CH_46L	24	CH_47L	24	CH_48L
25	UNUSED	25	UNUSED	25	CH_49H	25	CH_50H	25	CH_51H
26	CH_52H	26	UNUSED	26	CH_49L	26	CH_50L	26	CH_51L
27	CH_52L	27	CH_53H	27	CH_54H	27	CH_55H	27	CH_56H
28	UNUSED	28	CH_53L	28	CH_54L	28	CH_55L	28	CH_56L
29	UNUSED	29	CH_57H	29	CH_58H	29	CH_59H	29	CH_60H
30	UNUSED	30	CH_57L	30	CH_58L	30	CH_59L	30	CH_60L
31	CH_61H	31	CH_62H	31	CH_63H	31	CH_64H	31	SHIELD
32	CH_61L	32	CH_62L	32	CH_63L	32	CH_64L	32	UNUSED

TABLE 3-16: SMX-3005DS CONNECTOR PINS & SIGNAL ASSIGNMENTS

The SMX-3005DS incorporates an integral shield into the design of the PCB that attenuates noise and crosstalk between adjacent channels/modules. To properly utilize this feature, tie the appropriate front panel connector pins to the mating cable's common shield and/or ground. These pins are identified as "SHIELD" in Table 3-16

LOGICAL DIAGRAM

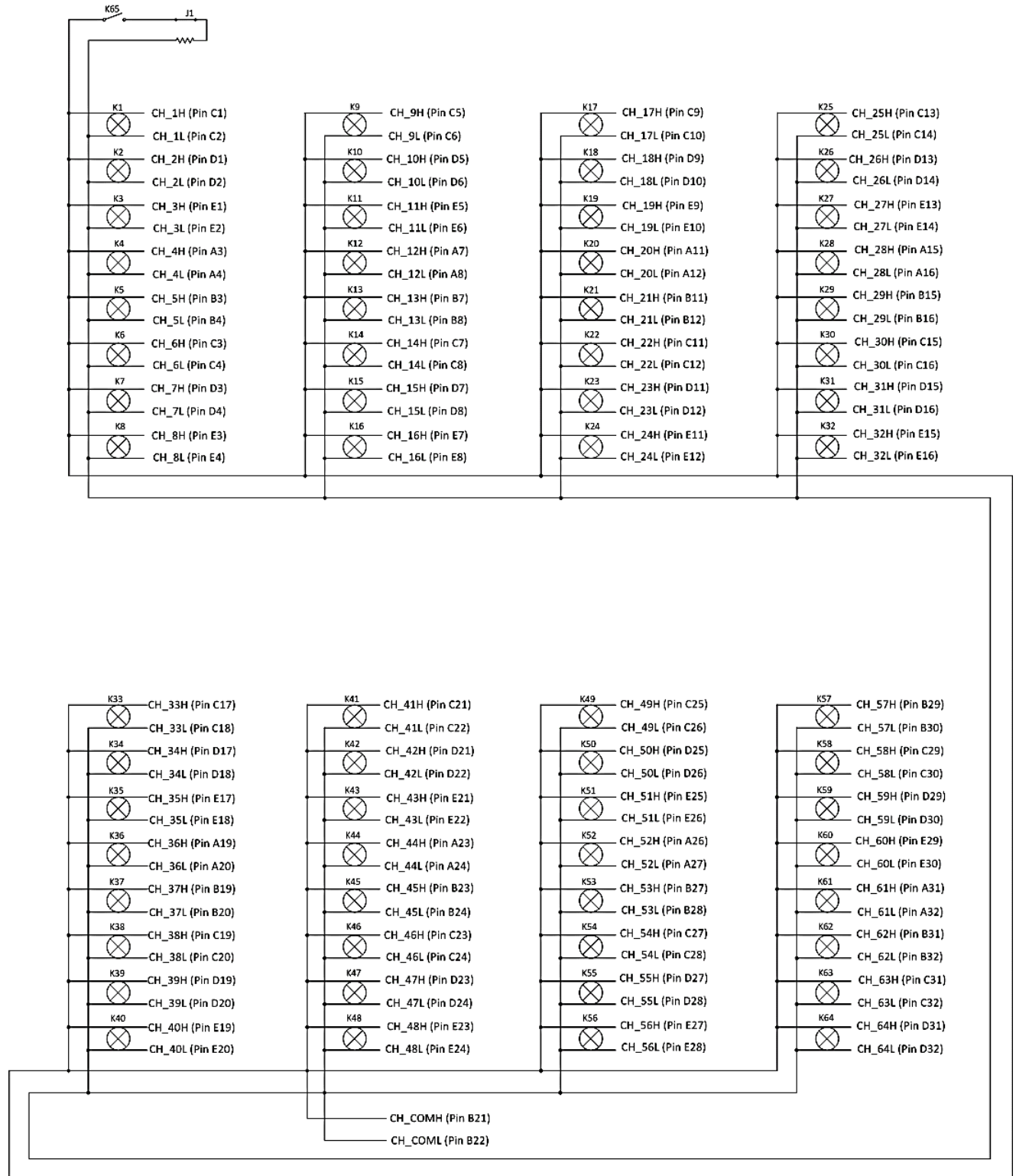

FIGURE 3-36: SMX-3005DS LOGICAL DIAGRAM

SMX-3005DS SPECIFICATIONS

GENERAL SPECIFICATIONS	
CHANNEL COUNT	(1) 1 x 64 2-wire Multiplexer
RELAY TYPE	Electromechanical, fail-safe
MAXIMUM SWITCHING VOLTAGE	300 V ac, 300 V dc
MAXIMUM SWITCHING CURRENT	2 A
MAXIMUM SWITCHING POWER	60 W dc, 62.5 VA
	<i>*Maximum switched power is at 30 V/ 2 A dc. Max switched power is derated non-linearly as voltage is increased.</i>
RATED SWITCH OPERATIONS	
Mechanical	1 x 10 ⁸ (no load)
Electrical	Min. 1 x 10 ⁵ @ (resistive load, 250VAC/0.25A), (resistive load, 30VDC/2A)
SWITCHING TIME	< 8 ms
PATH RESISTANCE	< 400 mΩ
INSULATION RESISTANCE	> 1 x 10 ⁹ Ω
MAXIMUM THERMAL OFFSET PER CHANNEL (HI-LO)	< 10 μV
CAPACITANCE	
Open channel	< 14 pF
Channel-mainframe	< 553 pF
High-low	< 349 pF
BANDWIDTH (-3 dB)	26 MHz (typical), 26 MHz (best), 25 MHz (worst)
INSERTION LOSS	
100 kHz	< 0.45 dB
1 MHz	< 0.46 dB
10 MHz	< 0.93 dB
CROSSTALK	
100 kHz	< -71 dB
1 MHz	< -53 dB
ISOLATION	
100 kHz	< -62 dB
1 MHz	< -55 dB

FOR MATING CONNECTOR, CRIMP PINS, AND OTHER ACCESSORIES, PLEASE REFER TO *APPENDIX B*

SMX-3006 SWITCH MODULE

(1) 1 x 128 1-WIRE FIXED MULTIPLEXER

The SMX-3006 high-density multiplexer module consists of one (1 x 128) 1-wire multiplexer.

The SMX-3006 can be controlled programmatically using IviSwch-compliant calls. Both path level programming and individual relay control are available. Refer to the host driver documentation for additional details.

Figure 3-38 provides a logical diagram of the switch module and identifies the switches used by the module. This information can be used for individual relay control through the driver. An optional terminal block provides screw termination points for external field wiring. This terminal block also includes cold junction compensation reference for more precise temperature measurements.

CONNECTOR PINS AND SIGNALS

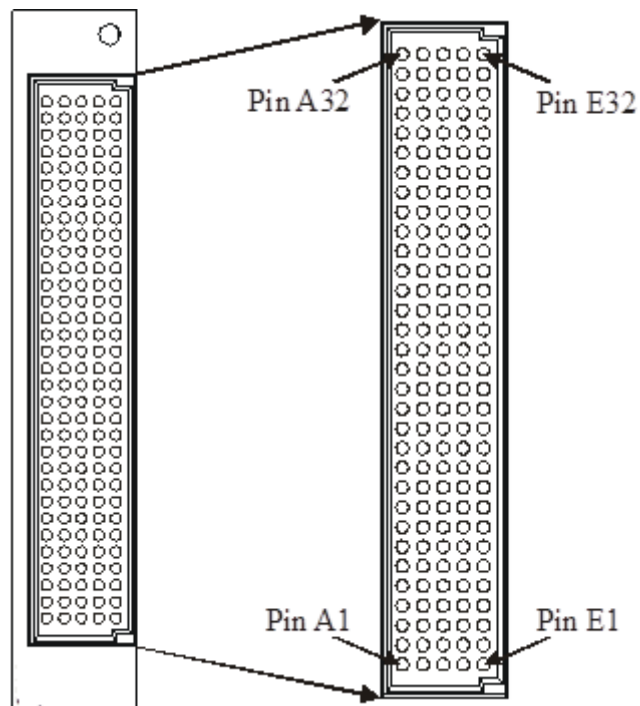

FIGURE 3-37: SMX-3006 FRONT PANEL CONNECTOR PINS (FRONT VIEW)

Row A		Row B		Row C		Row D		Row E	
Pin	Signal	Pin	Signal	Pin	Signal	Pin	Signal	Pin	Signal
1	UNUSED	1	UNUSED	1	CH_1H	1	CH_2H	1	CH_3H
2	SHIELD	2	UNUSED	2	CH_1L	2	CH_2L	2	CH_3L
3	CH_4H	3	CH_5H	3	CH_6H	3	CH_7H	3	CH_8H
4	CH_4L	4	CH_5L	4	CH_6L	4	CH_7L	4	CH_8L
5	COM_1W	5	UNUSED	5	CH_9H	5	CH_10H	5	CH_11H
6	SHIELD	6	UNUSED	6	CH_9L	6	CH_10L	6	CH_11L
7	CH_12H	7	CH_13H	7	CH_14H	7	CH_15H	7	CH_16H
8	CH_12L	8	CH_13L	8	CH_14L	8	CH_15L	8	CH_16L
9	UNUSED	9	UNUSED	9	CH_17H	9	CH_18H	9	CH_19H
10	SHIELD	10	UNUSED	10	CH_17L	10	CH_18L	10	CH_19L
11	CH_20H	11	CH_21H	11	CH_22H	11	CH_23H	11	CH_24H
12	CH_20L	12	CH_21L	12	CH_22L	12	CH_23L	12	CH_24L
13	UNUSED	13	UNUSED	13	CH_25H	13	CH_26H	13	CH_27H
14	SHIELD	14	UNUSED	14	CH_25L	14	CH_26L	14	CH_27L
15	CH_28H	15	CH_29H	15	CH_30H	15	CH_31H	15	CH_32H
16	CH_28L	16	CH_29L	16	CH_30L	16	CH_31L	16	CH_32L
17	UNUSED	17	UNUSED	17	CH_33H	17	CH_34H	17	CH_35H
18	SHIELD	18	UNUSED	18	CH_33L	18	CH_34L	18	CH_35L
19	CH_36H	19	CH_37H	19	CH_38H	19	CH_39H	19	CH_40H
20	CH_36L	20	CH_37L	20	CH_38L	20	CH_39L	20	CH_40L
21	UNUSED	21	UNUSED	21	CH_41H	21	CH_42H	21	CH_43H
22	SHIELD	22	UNUSED	22	CH_41L	22	CH_42L	22	CH_43L
23	CH_44H	23	CH_45H	23	CH_46H	23	CH_47H	23	CH_48H
24	CH_44L	24	CH_45L	24	CH_46L	24	CH_47L	24	CH_48L
25	UNUSED	25	UNUSED	25	CH_49H	25	CH_50H	25	CH_51H
26	CH_52H	26	UNUSED	26	CH_49L	26	CH_50L	26	CH_51L
27	CH_52L	27	CH_53H	27	CH_54H	27	CH_55H	27	CH_56H
28	UNUSED	28	CH_53L	28	CH_54L	28	CH_55L	28	CH_56L
29	UNUSED	29	CH_57H	29	CH_58H	29	CH_59H	29	CH_60H
30	UNUSED	30	CH_57L	30	CH_58L	30	CH_59L	30	CH_60L
31	CH_61H	31	CH_62H	31	CH_63H	31	CH_64H	31	SHIELD
32	CH_61L	32	CH_62L	32	CH_63L	32	CH_64L	32	UNUSED

TABLE 3-17: SMX-3006 PINS & SIGNAL ASSIGNMENTS

The SMX-3006 incorporates an integral shield into the design of the PCB that attenuates noise and crosstalk between adjacent channels/modules. To properly utilize this feature, tie the appropriate front panel connector pins to the mating cable's common shield and/or ground. These pins are identified as "SHIELD" in Table 3-17

LOGICAL DIAGRAM

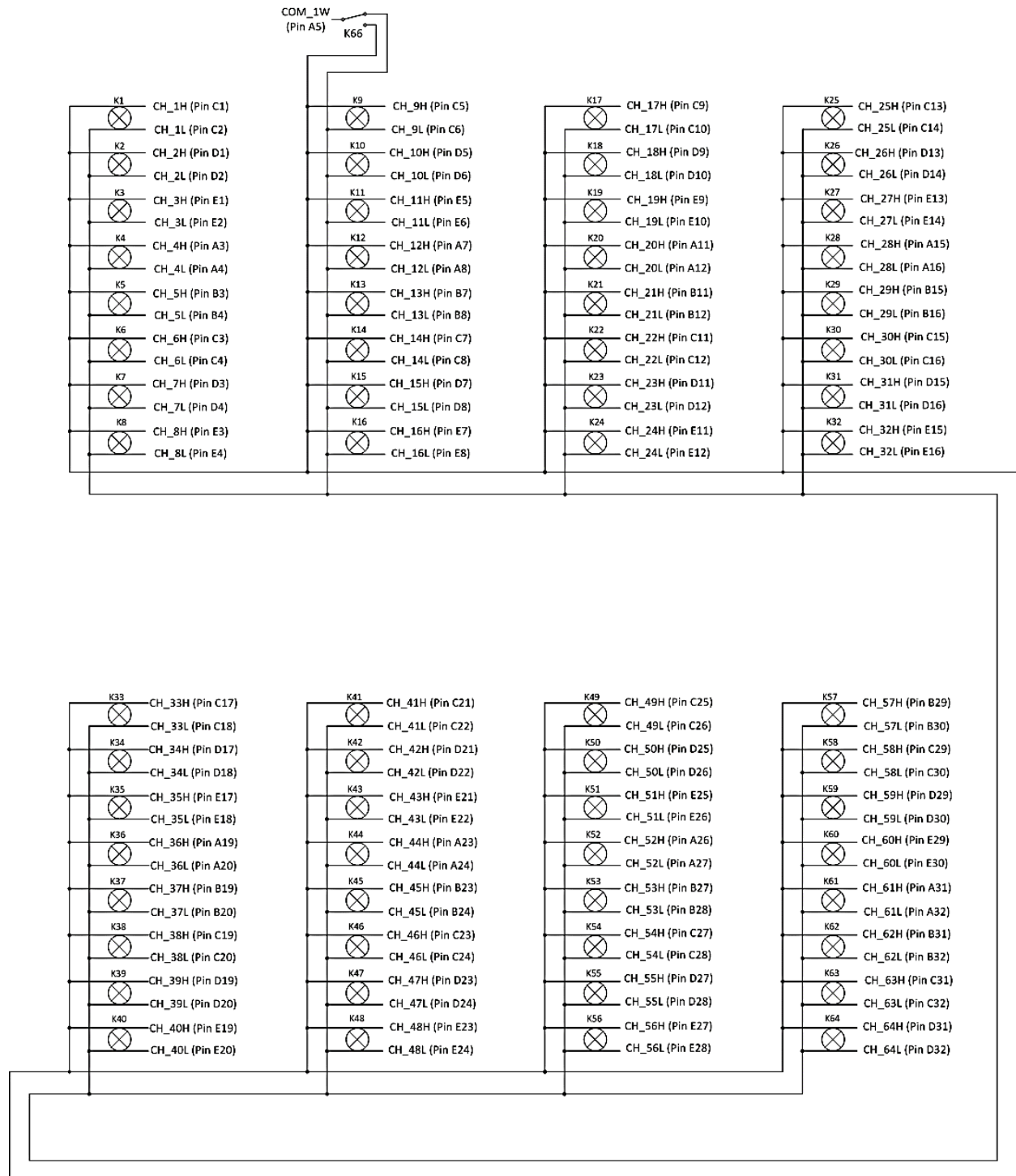

FIGURE 3-38: SMX-3006 LOGICAL DIAGRAM

SMX-3006 SPECIFICATIONS

GENERAL SPECIFICATIONS	
CHANNEL COUNT	(1) 1 x 128 1-wire Multiplexer
RELAY TYPE	Electromechanical, fail-safe
MAXIMUM SWITCHING VOLTAGE	300 V ac, 300 V dc
MAXIMUM SWITCHING CURRENT	2 A
MAXIMUM SWITCHING POWER	60 W dc, 62.5 VA
	<i>*Maximum switched power is at 30 V/ 2 A dc. Max switched power is derated non-linearly as voltage is increased.</i>
RATED SWITCH OPERATIONS	
Mechanical	1 x 10 ⁸ (no load)
Electrical	Min. 1 x 10 ⁵ @ (resistive load, 250VAC/0.25A), (resistive load, 30VDC/2A)
SWITCHING TIME	< 8 ms
PATH RESISTANCE	< 500 mΩ
INSULATION RESISTANCE	> 1 x 10 ⁹ Ω
MAXIMUM THERMAL OFFSET PER CHANNEL (HI-LO)	
	< 10 μV
CAPACITANCE	
Open channel	< 33 pF
Channel-mainframe	< 553 pF
BANDWIDTH (-3 dB)	
	38 MHz (typical), 38 MHz (best), 37 MHz (worst)
INSERTION LOSS	
100 kHz	< 0.21 dB
1 MHz	< 0.75 dB
10 MHz	< 1.24 dB
CROSSTALK	
100 kHz	< -69 dB
1 MHz	< -63 dB
ISOLATION	
100 kHz	< -63 dB
1 MHz	< -51 dB

FOR MATING CONNECTOR, CRIMP PINS, AND OTHER ACCESSORIES, PLEASE REFER TO *APPENDIX B*

SMX-3007 SWITCH MODULE

(2) 1 X 64 1-WIRE FIXED MULTIPLEXER

The SMX-3007 high-density multiplexer module consists of two (1 x 64) 1-wire multiplexers.

The SMX-3007 can be controlled programmatically using IviSwch-compliant calls. Both path level programming and individual relay control are available. Refer to the host driver documentation for additional details. Figure 3-40 provides a logical diagram of the switch module and identifies the switches used by the module. This information can be used for individual relay control through the driver. An optional terminal block provides screw termination points for external field wiring. This terminal block also includes cold junction compensation reference for more precise temperature measurements.

CONNECTOR PINS AND SIGNALS

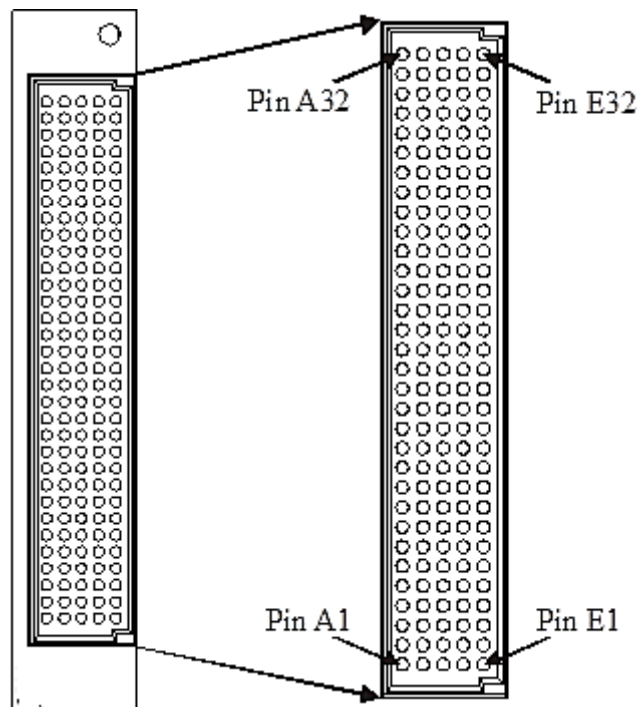

FIGURE 3-39: SMX-3007 FRONT PANEL CONNECTOR PINS (FRONT VIEW)

Row A		Row B		Row C		Row D		Row E	
Pin	Signal	Pin	Signal	Pin	Signal	Pin	Signal	Pin	Signal
1	UNUSED	1	UNUSED	1	CH1_1H	1	CH1_2H	1	CH1_3H
2	SHIELD	2	UNUSED	2	CH1_1L	2	CH1_2L	2	CH1_3L
3	CH1_4H	3	CH1_5H	3	CH1_6H	3	CH1_7H	3	CH1_8H
4	CH1_4L	4	CH1_5L	4	CH1_6L	4	CH1_7L	4	CH1_8L
5	CH1_1W	5	UNUSED	5	CH1_9H	5	CH1_10H	5	CH1_11H
6	SHIELD	6	UNUSED	6	CH1_9L	6	CH1_10L	6	CH1_11L
7	CH1_12H	7	CH1_13H	7	CH1_14H	7	CH1_15H	7	CH1_16H
8	CH1_12L	8	CH1_13L	8	CH1_14L	8	CH1_15L	8	CH1_16L
9	UNUSED	9	UNUSED	9	CH1_17H	9	CH1_18H	9	CH1_19H
10	SHIELD	10	UNUSED	10	CH1_17L	10	CH1_18L	10	CH1_19L
11	CH1_20H	11	CH1_21H	11	CH1_22H	11	CH1_23H	11	CH1_24H
12	CH1_20L	12	CH1_21L	12	CH1_22L	12	CH1_23L	12	CH1_24L
13	UNUSED	13	UNUSED	13	CH1_25H	13	CH1_26H	13	CH1_27H
14	SHIELD	14	UNUSED	14	CH1_25L	14	CH1_26L	14	CH1_27L
15	CH1_28H	15	CH1_29H	15	CH1_30H	15	CH1_31H	15	CH1_32H
16	CH1_28L	16	CH1_29L	16	CH1_30L	16	CH1_31L	16	CH1_32L
17	UNUSED	17	UNUSED	17	CH2_1H	17	CH2_2H	17	CH2_3H
18	SHIELD	18	UNUSED	18	CH2_1L	18	CH2_2L	18	CH2_3L
19	CH2_4H	19	CH2_5H	19	CH2_6H	19	CH2_7H	19	CH2_8H
20	CH2_4L	20	CH2_5L	20	CH2_6L	20	CH2_7L	20	CH2_8L
21	CH2_1W	21	UNUSED	21	CH2_9H	21	CH2_10H	21	CH2_11H
22	SHIELD	22	UNUSED	22	CH2_9L	22	CH2_10L	22	CH2_11L
23	CH2_12H	23	CH2_13H	23	CH2_14H	23	CH2_15H	23	CH2_16H
24	CH2_12L	24	CH2_13L	24	CH2_14L	24	CH2_15L	24	CH2_16L
25	UNUSED	25	UNUSED	25	CH2_17H	25	CH2_18H	25	CH2_19H
26	CH2_20H	26	UNUSED	26	CH2_17L	26	CH2_18L	26	CH2_19L
27	CH2_20L	27	CH2_21H	27	CH2_22H	27	CH2_23H	27	CH2_24H
28	UNUSED	28	CH2_21L	28	CH2_22L	28	CH2_23L	28	CH2_24L
29	UNUSED	29	CH2_25H	29	CH2_26H	29	CH2_27H	29	CH2_28H
30	UNUSED	30	CH2_25L	30	CH2_26L	30	CH2_27L	30	CH2_28L
31	CH2_29H	31	CH2_30H	31	CH2_31H	31	CH2_32H	31	SHIELD
32	CH2_29L	32	CH2_30L	32	CH2_31L	32	CH2_32L	32	UNUSED

TABLE 3-18: SMX-3007 PINS & SIGNAL ASSIGNMENTS

The SMX-3007 incorporates an integral shield into the design of the PCB that attenuates noise and crosstalk between adjacent channels/modules. To properly utilize this feature, tie the appropriate front panel connector pins to the mating cable's common shield and/or ground. These pins are identified as "SHIELD" in Table 3-18.

Row A		Row B		Row C		Row D		Row E	
Pin	Signal	Pin	Signal	Pin	Signal	Pin	Signal	Pin	Signal
1	UNUSED	1	UNUSED	1	CH1_1H	1	CH1_2H	1	CH1_3H
2	SHIELD	2	UNUSED	2	CH1_1L	2	CH1_2L	2	CH1_3L
3	CH1_4H	3	CH1_5H	3	CH1_6H	3	CH1_7H	3	CH1_8H
4	CH1_4L	4	CH1_5L	4	CH1_6L	4	CH1_7L	4	CH1_8L
5	CH1_1W	5	UNUSED	5	CH1_9H	5	CH1_10H	5	CH1_11H
6	SHIELD	6	UNUSED	6	CH1_9L	6	CH1_10L	6	CH1_11L
7	CH1_12H	7	CH1_13H	7	CH1_14H	7	CH1_15H	7	CH1_16H
8	CH1_12L	8	CH1_13L	8	CH1_14L	8	CH1_15L	8	CH1_16L
9	UNUSED	9	UNUSED	9	CH1_17H	9	CH1_18H	9	CH1_19H
10	SHIELD	10	UNUSED	10	CH1_17L	10	CH1_18L	10	CH1_19L
11	CH1_20H	11	CH1_21H	11	CH1_22H	11	CH1_23H	11	CH1_24H
12	CH1_20L	12	CH1_21L	12	CH1_22L	12	CH1_23L	12	CH1_24L
13	UNUSED	13	UNUSED	13	CH1_25H	13	CH1_26H	13	CH1_27H
14	SHIELD	14	UNUSED	14	CH1_25L	14	CH1_26L	14	CH1_27L
15	CH1_28H	15	CH1_29H	15	CH1_30H	15	CH1_31H	15	CH1_32H
16	CH1_28L	16	CH1_29L	16	CH1_30L	16	CH1_31L	16	CH1_32L
17	UNUSED	17	UNUSED	17	CH2_1H	17	CH2_2H	17	CH2_3H
18	SHIELD	18	UNUSED	18	CH2_1L	18	CH2_2L	18	CH2_3L
19	CH2_4H	19	CH2_5H	19	CH2_6H	19	CH2_7H	19	CH2_8H
20	CH2_4L	20	CH2_5L	20	CH2_6L	20	CH2_7L	20	CH2_8L
21	CH2_1W	21	UNUSED	21	CH2_9H	21	CH2_10H	21	CH2_11H
22	SHIELD	22	UNUSED	22	CH2_9L	22	CH2_10L	22	CH2_11L
23	CH2_12H	23	CH2_13H	23	CH2_14H	23	CH2_15H	23	CH2_16H
24	CH2_12L	24	CH2_13L	24	CH2_14L	24	CH2_15L	24	CH2_16L
25	UNUSED	25	UNUSED	25	CH2_17H	25	CH2_18H	25	CH2_19H
26	CH2_20H	26	UNUSED	26	CH2_17L	26	CH2_18L	26	CH2_19L
27	CH2_20L	27	CH2_21H	27	CH2_22H	27	CH2_23H	27	CH2_24H
28	UNUSED	28	CH2_21L	28	CH2_22L	28	CH2_23L	28	CH2_24L
29	UNUSED	29	CH2_25H	29	CH2_26H	29	CH2_27H	29	CH2_28H
30	UNUSED	30	CH2_25L	30	CH2_26L	30	CH2_27L	30	CH2_28L
31	CH2_29H	31	CH2_30H	31	CH2_31H	31	CH2_32H	31	SHIELD
32	CH2_29L	32	CH2_30L	32	CH2_31L	32	CH2_32L	32	UNUSED

Table 3-18

LOGICAL DIAGRAM

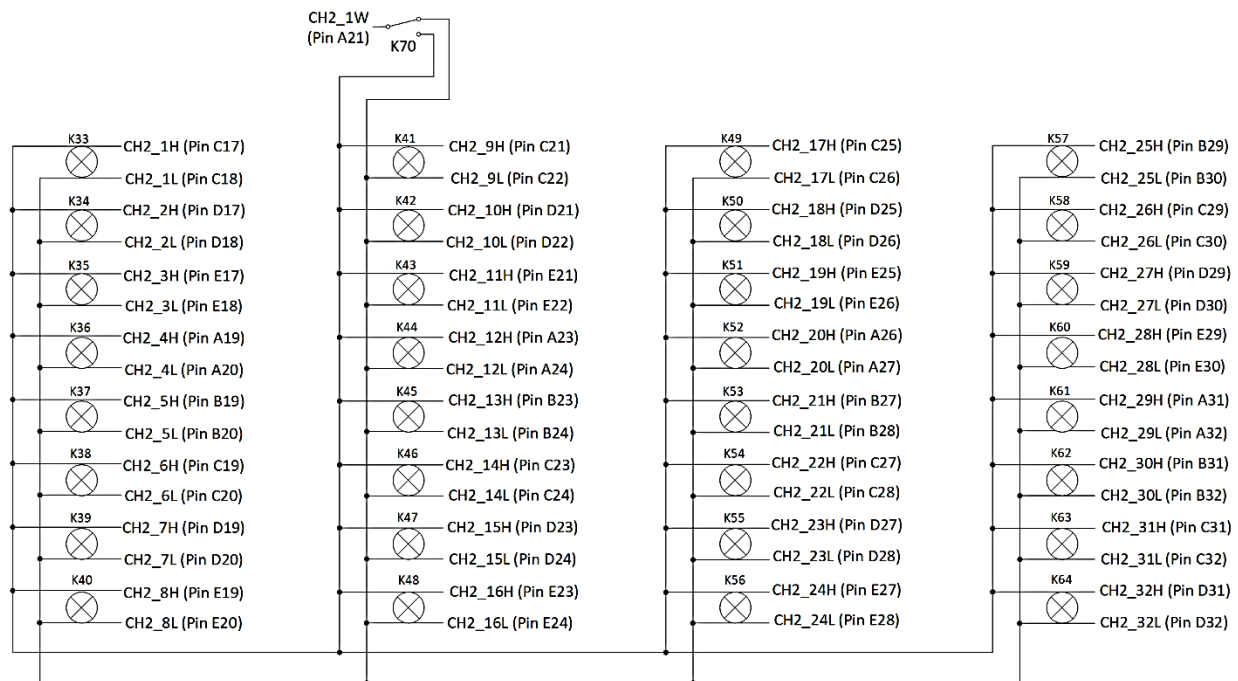
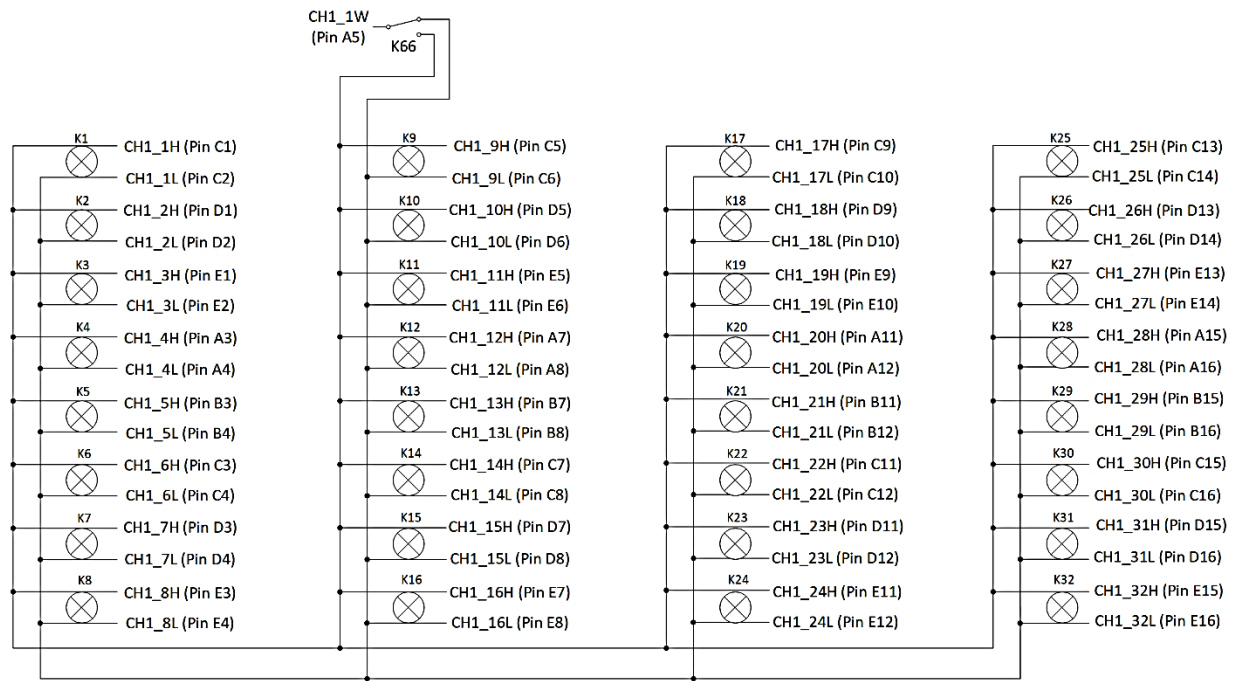

FIGURE 3-40: SMX-3007 LOGICAL DIAGRAM

SMX-3007 SPECIFICATIONS

GENERAL SPECIFICATIONS	
CHANNEL COUNT	(2) 1 x 64 1-wire Multiplexer
RELAY TYPE	Electromechanical, fail-safe
MAXIMUM SWITCHING VOLTAGE	300 V ac, 300 V dc
MAXIMUM SWITCHING CURRENT	2 A
MAXIMUM SWITCHING POWER	60 W dc, 62.5 VA
	<i>*Maximum switched power is at 30 V/ 2 A dc. Max switched power is derated non-linearly as voltage is increased.</i>
RATED SWITCH OPERATIONS	
Mechanical	1 x 10 ⁸ (no load)
Electrical	Min. 1 x 10 ⁵ @ (resistive load, 250VAC/0.25A), (resistive load, 30VDC/2A)
SWITCHING TIME	< 8 ms
PATH RESISTANCE	< 400 mΩ
INSULATION RESISTANCE	> 1 x 10 ⁹ Ω
MAXIMUM THERMAL OFFSET PER CHANNEL (HI-LO)	
	< 10 μV
CAPACITANCE	
Open channel	< 32 pF
Channel-mainframe	< 318 pF
BANDWIDTH (-3 dB)	
	39 MHz (typical), 40MHz (best), 38 MHz (worst)
INSERTION LOSS	
100 kHz	< 0.2 dB
1 MHz	< 0.5 dB
10 MHz	< 1.09 dB
CROSSTALK	
100 kHz	< -71 dB
1 MHz	< -61 dB
ISOLATION	
100 kHz	< -68 dB
1 MHz	< -53 dB

FOR MATING CONNECTOR, CRIMP PINS, AND OTHER ACCESSORIES, PLEASE REFER TO *APPENDIX B*

SMX-3276, MATRIX MODULE

(2) 1 X 38 2-WIRE FULLY CONFIGURABLE MULTIPLEXER

The SMX-3276, PXIe high-density multiplexer modules designed for scanning of multiple points to a common bus, in 1, 2, or 4-wire configurations. The SMX-3276 consists of two individual (1 x 76) 1-wire, or two (1x38) 2-wire multiplexers or one 1x76 2-wire mux, that can be interconnected under program control (via bussing relays) to configure larger multiplexers as required. This eliminates external wiring and helps reduce unterminated stubs.

The SMX-3276 incorporates extensive signal shielding and exposes shield pins on the front panel connector for tying to the cable shield. This preserves signal integrity throughout the signal path by maintaining the signals at the same reference level as the UUT. In addition, meticulous signal routing is done for impedance matching, signal shielding and cross talk reduction, allowing the SMX-3276 to achieve best in class switching performance with a bandwidth of > 30 MHz. This performance allows the card to be used with high frequency signals, and signals that have fast rise times and narrow pulse widths.

CONNECTOR PINS AND SIGNALS

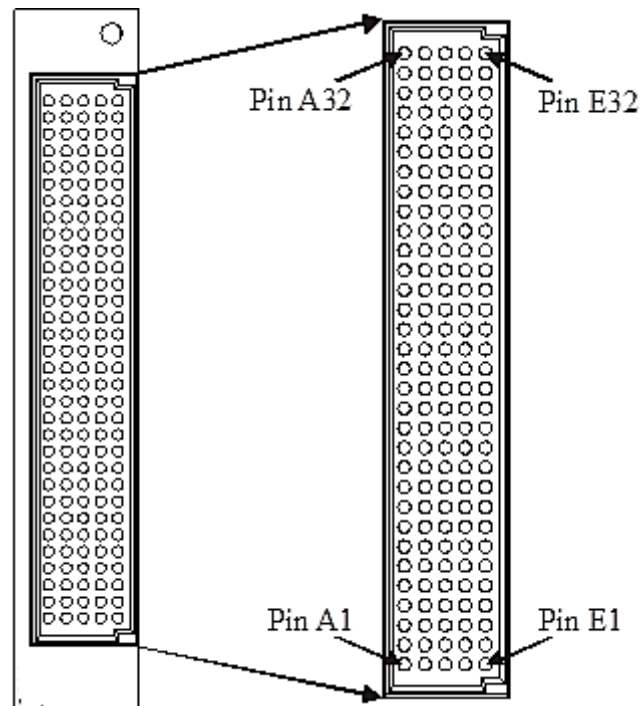

FIGURE 3-41: SMX-3276 FRONT PANEL CONNECTOR (FRONT VIEW)

Row A		Row B		Row C		Row D		Row E	
Pin	Signal	Pin	Signal	Pin	Signal	Pin	Signal	Pin	Signal
1	USR_SHIELD	1	CH1_37L	1	CH1_37H	1	CH1_38L	1	CH1_38H
2	CH1_3L	2	CH1_4L	2	CH1_8L	2	CH1_7L	2	CH1_1L
3	CH1_3H	3	CH1_4H	3	CH1_8H	3	CH1_7H	3	CH1_1H
4	CH1_5L	4	CH1_6L	4	CH1_2L	4	CH1_9L	4	CH1_11L
5	CH1_5H	5	CH1_6H	5	CH1_2H	5	CH1_9H	5	CH1_11H
6	CH1_10L	6	CH1_15L	6	CH1_13L	6	CH1_17L	6	CH1_18L
7	CH1_10H	7	CH1_15H	7	CH1_13H	7	CH1_17H	7	CH1_18H
8	CH1_14L	8	CH1_26L	8	CH1_12L	8	CH1_27L	8	CH1_16L
9	CH1_14H	9	CH1_26H	9	CH1_12H	9	CH1_27H	9	CH1_16H
10	CH1_24L	10	CH1_19L	10	CH1_21L	10	CH1_25L	10	CH1_22L
11	CH1_24H	11	CH1_19H	11	CH1_21H	11	CH1_25H	11	CH1_22H
12	CH1_36L	12	CH1_20L	12	CH1_30L	12	CH1_23L	12	CH1_31L
13	CH1_36H	13	CH1_20H	13	CH1_30H	13	CH1_23H	13	CH1_31H
14	CH1_COML	14	CH1_28L	14	CH1_29L	14	CH1_35L	14	CH1_34L
15	CH1_COMH	15	CH1_28H	15	CH1_29H	15	CH1_35H	15	CH1_34H
16	CH1_33L	16	CH1_32L	16	CH2_5L	16	CH2_4L	16	CH2_COML
17	CH1_33H	17	CH1_32H	17	CH2_5H	17	CH2_4H	17	CH2_COMH
18	CH2_1L	18	CH2_8L	18	CH2_3L	18	CH2_2L	18	CH2_9L
19	CH2_1H	19	CH2_8H	19	CH2_3H	19	CH2_2H	19	CH2_9H
20	CH2_7L	20	CH2_14L	20	CH2_13L	20	CH2_6L	20	USR_SHIELD
21	CH2_7H	21	CH2_14H	21	CH2_13H	21	CH2_6H	21	USR_SHIELD
22	CH2_11L	22	CH2_12L	22	CH2_17L	22	CH2_10L	22	CH2_18L
23	CH2_11H	23	CH2_12H	23	CH2_17H	23	CH2_10H	23	CH2_18H
24	CH2_23L	24	CH2_16L	24	CH2_15L	24	CH2_19L	24	CH2_22L
25	CH2_23H	25	CH2_16H	25	CH2_15H	25	CH2_19H	25	CH2_22H
26	CH2_27L	26	CH2_20L	26	CH2_26L	26	CH2_29L	26	CH2_21L
27	CH2_27H	27	CH2_20H	27	CH2_26H	27	CH2_29H	27	CH2_21H
28	CH2_30L	28	CH2_25L	28	CH2_34L	28	CH2_24L	28	CH2_32L
29	CH2_30H	29	CH2_25H	29	CH2_34H	29	CH2_24H	29	CH2_32H
30	CH2_31L	30	CH2_33L	30	CH2_28L	30	CH2_36L	30	CH2_35L
31	CH2_31H	31	CH2_33H	31	CH2_28H	31	CH2_36H	31	CH2_35H
32	USR_SHIELD	32	CH2_37L	32	CH2_37H	32	CH2_38L	32	CH2_38H

TABLE 3-19: SMX-3276 CONNECTOR PINS & SIGNAL ASSIGNMENTS

LOGICAL DIAGRAM

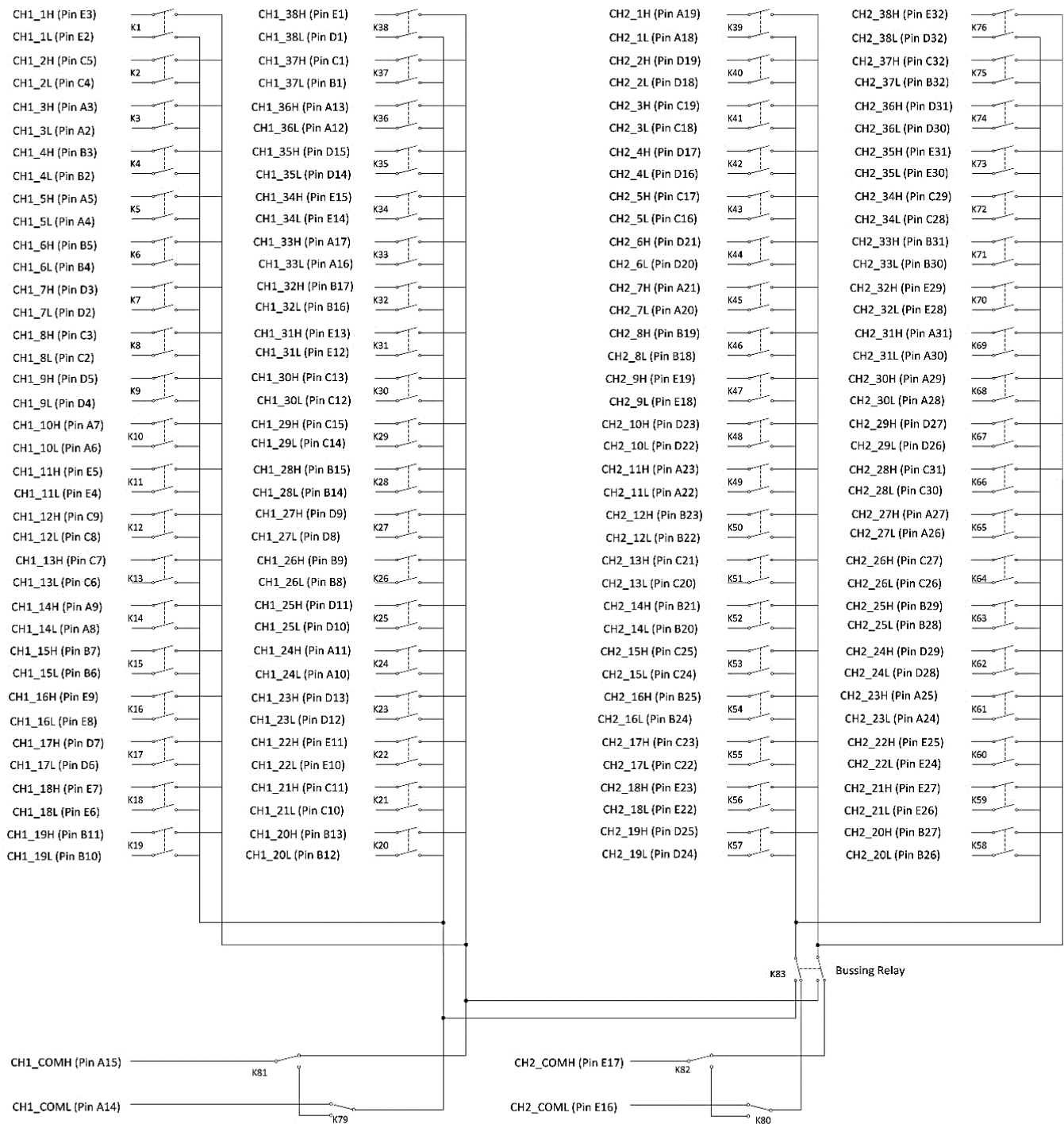

FIGURE 3-42: SMX-3276 LOGICAL DIAGRAM

SMX-3276 SPECIFICATIONS

GENERAL SPECIFICATIONS	
CHANNEL COUNT	(2) 1 x76 1-Wire Multiplexer, (2) 1 x38 2-Wire Multiplexer, (1) 1 x 76 2-Wire Multiplexer, Fully configurable
RELAY TYPE	Electromechanical, fail-safe
MAXIMUM SWITCHING VOLTAGE	300 V dc, 300 V ac
MAXIMUM SWITCHING CURRENT	2 A
MAXIMUM SWITCHING POWER	60 W dc, 62.5 VA
<i>*Maximum switched power is at 30 V/ 2 A dc. Max switched power is derated non-linearly as voltage is increased.</i>	
RATED SWITCH OPERATIONS	
Mechanical	1 x 10 ⁸ (no load)
Electrical	Min. 1 x 10 ⁵ @ (resistive load,250VAC/0.25A), (resistive load,30VDC/2A)
SWITCHING TIME	< 8 ms
PATH RESISTANCE	< 500 mΩ
INSULATION RESISTANCE	> 1 x 10 ⁹ Ω
MAXIMUM THERMAL OFFSET PER CHANNEL (HI-LO)	< 10 μV
CAPACITANCE	
Open channel	< 58 pF
Channel-mainframe	< 375 pF
High-low	< 390 pF
BANDWIDTH (-3 dB)	
(2) 1 x76 1-Wire Multiplexer	36 MHz (best), 30 MHz (worst)
(2) 1 x38 2-Wire Multiplexer	53 MHz (best), 42 MHz (worst)
(1) 1 x76 2- Wire Multiplexer	25 MHz (best), 20 MHz (worst)
CROSSTALK (TYPICAL) - 2WIRE	
100 KHz	< -66 dB
1 MHz	< -59 dB
ISOLATION (TYPICAL)- 2WIRE	
100 kHz	< -77 dB
1 MHz	< -55 dB
INSERTION LOSS- 2WIRE	
100 kHz	< 0.56 dB
1 MHz	< 0.58 dB
10 MHz	< 0.62 dB

FOR MATING CONNECTOR, CRIMP PINS, AND OTHER ACCESSORIES, PLEASE REFER TO *APPENDIX B*

SMX-3276, MATRIX MODULE

(2) 1 X 38 2-WIRE FULLY CONFIGURABLE MULTIPLEXER

The SMX-3276DS, PXIe high-density multiplexer modules designed for scanning of multiple points to a common bus, in 1, 2, or 4-wire configurations. The SMX-3276DS consists of two individual (1 x 76) 1-wire, or two (1x38) 2-wire multiplexers or one 1x76 2-wire mux, that can be interconnected under program control (via bussing relays) to configure larger multiplexers as required. This eliminates external wiring and helps reduce unterminated stubs.

In contrast to the SMX-3276 the SMX-3276DS has internal residual voltage discharge relays that can be enabled to momentarily short out the measurement path when changing from one input channel to the next. This dissipates any voltage held by the wiring and instrument input capacitance. These relays protect sensitive devices, such as CMOS circuits, from residual voltages caused by previous high-voltage measurements. This feature can also be disabled in low-voltage applications where maximum throughput speed is important.

The SMX-3276DS incorporates extensive signal shielding and exposes shield pins on the front panel connector for tying to the cable shield. This preserves signal integrity throughout the signal path by maintaining the signals at the same reference level as the UUT. In addition, meticulous signal routing is done for impedance matching, signal shielding and cross talk reduction, allowing the SMX-3276DS to achieve best in class switching performance with a bandwidth of > 30 MHz. This performance allows the card to be used with high frequency signals, and signals that have fast rise times and narrow pulse widths.

NOTE SMX-3276DS where DS stands for DISCHARGE relays support

CONNECTOR PINS AND SIGNALS

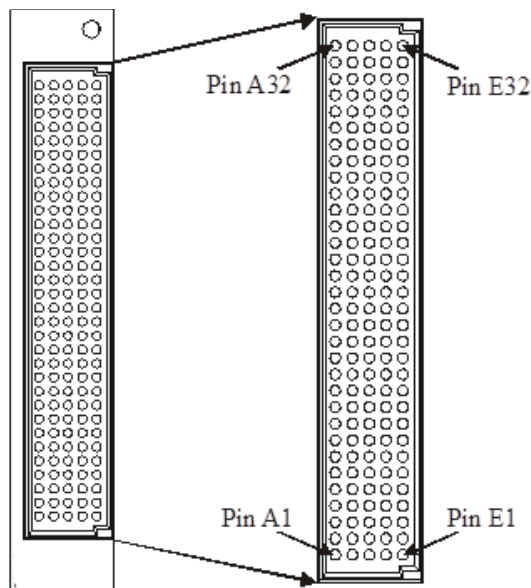

FIGURE 3-43: SMX-3276DS FRONT PANEL CONNECTOR (FRONT VIEW)

Row A		Row B		Row C		Row D		Row E	
Pin	Signal	Pin	Signal	Pin	Signal	Pin	Signal	Pin	Signal
1	USR_SHIELD	1	CH1_37L	1	CH1_37H	1	CH1_38L	1	CH1_38H
2	CH1_3L	2	CH1_4L	2	CH1_8L	2	CH1_7L	2	CH1_1L
3	CH1_3H	3	CH1_4H	3	CH1_8H	3	CH1_7H	3	CH1_1H
4	CH1_5L	4	CH1_6L	4	CH1_2L	4	CH1_9L	4	CH1_11L
5	CH1_5H	5	CH1_6H	5	CH1_2H	5	CH1_9H	5	CH1_11H
6	CH1_10L	6	CH1_15L	6	CH1_13L	6	CH1_17L	6	CH1_18L
7	CH1_10H	7	CH1_15H	7	CH1_13H	7	CH1_17H	7	CH1_18H
8	CH1_14L	8	CH1_26L	8	CH1_12L	8	CH1_27L	8	CH1_16L
9	CH1_14H	9	CH1_26H	9	CH1_12H	9	CH1_27H	9	CH1_16H
10	CH1_24L	10	CH1_19L	10	CH1_21L	10	CH1_25L	10	CH1_22L
11	CH1_24H	11	CH1_19H	11	CH1_21H	11	CH1_25H	11	CH1_22H
12	CH1_36L	12	CH1_20L	12	CH1_30L	12	CH1_23L	12	CH1_31L
13	CH1_36H	13	CH1_20H	13	CH1_30H	13	CH1_23H	13	CH1_31H
14	CH1_COML	14	CH1_28L	14	CH1_29L	14	CH1_35L	14	CH1_34L
15	CH1_COMH	15	CH1_28H	15	CH1_29H	15	CH1_35H	15	CH1_34H
16	CH1_33L	16	CH1_32L	16	CH2_5L	16	CH2_4L	16	CH2_COML
17	CH1_33H	17	CH1_32H	17	CH2_5H	17	CH2_4H	17	CH2_COMH
18	CH2_1L	18	CH2_8L	18	CH2_3L	18	CH2_2L	18	CH2_9L
19	CH2_1H	19	CH2_8H	19	CH2_3H	19	CH2_2H	19	CH2_9H
20	CH2_7L	20	CH2_14L	20	CH2_13L	20	CH2_6L	20	USR_SHIELD
21	CH2_7H	21	CH2_14H	21	CH2_13H	21	CH2_6H	21	USR_SHIELD
22	CH2_11L	22	CH2_12L	22	CH2_17L	22	CH2_10L	22	CH2_18L
23	CH2_11H	23	CH2_12H	23	CH2_17H	23	CH2_10H	23	CH2_18H
24	CH2_23L	24	CH2_16L	24	CH2_15L	24	CH2_19L	24	CH2_22L
25	CH2_23H	25	CH2_16H	25	CH2_15H	25	CH2_19H	25	CH2_22H
26	CH2_27L	26	CH2_20L	26	CH2_26L	26	CH2_29L	26	CH2_21L
27	CH2_27H	27	CH2_20H	27	CH2_26H	27	CH2_29H	27	CH2_21H
28	CH2_30L	28	CH2_25L	28	CH2_34L	28	CH2_24L	28	CH2_32L
29	CH2_30H	29	CH2_25H	29	CH2_34H	29	CH2_24H	29	CH2_32H
30	CH2_31L	30	CH2_33L	30	CH2_28L	30	CH2_36L	30	CH2_35L
31	CH2_31H	31	CH2_33H	31	CH2_28H	31	CH2_36H	31	CH2_35H
32	USR_SHIELD	32	CH2_37L	32	CH2_37H	32	CH2_38L	32	CH2_38H

TABLE 3-20: SMX-3276DS CONNECTOR PINS & SIGNAL ASSIGNMENTS

LOGICAL DIAGRAM

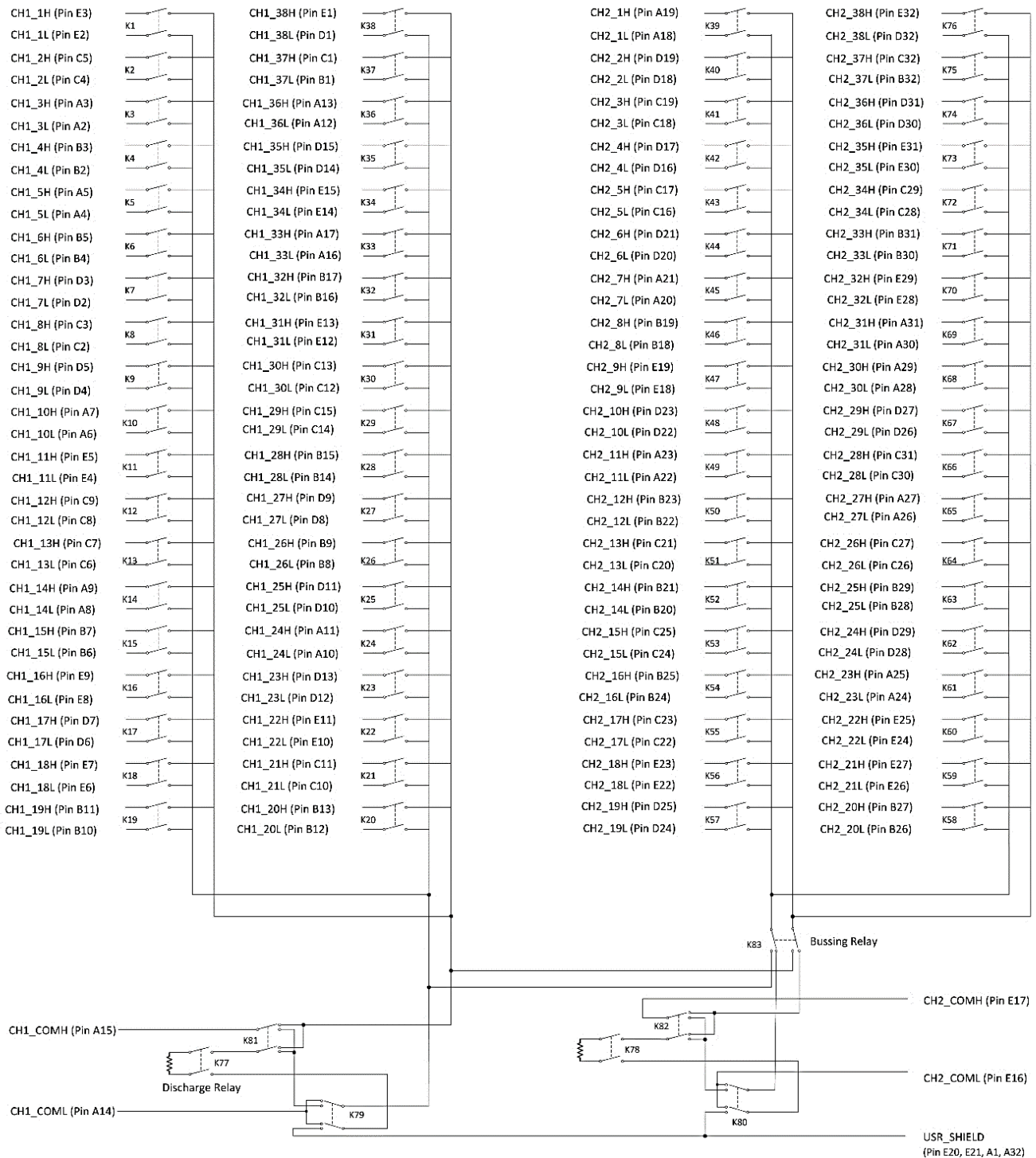

FIGURE 3-44: SMX-3276DS LOGICAL DIAGRAM

SMX-3276DS SPECIFICATIONS

GENERAL SPECIFICATIONS	
CHANNEL COUNT	(2) 1 x76 1-Wire Multiplexer, (2) 1 x38 2-Wire Multiplexer, (1) 1 x 76 2-Wire Multiplexer, Fully configurable
RELAY TYPE	Electromechanical, fail-safe
MAXIMUM SWITCHING VOLTAGE	300 V dc, 300 V ac
MAXIMUM SWITCHING CURRENT	2 A
MAXIMUM SWITCHING POWER	60 W dc, 62.5 VA
<i>*Maximum switched power is at 30 V/ 2 A dc. Max switched power is derated non-linearly as voltage is increased.</i>	
RATED SWITCH OPERATIONS	
Mechanical	1 x 10 ⁸ (no load)
Electrical	Min. 1 x 10 ⁵ @ (resistive load,250VAC/0.25A), (resistive load,30VDC/2A)
SWITCHING TIME	< 8 ms
PATH RESISTANCE	< 500 mΩ
INSULATION RESISTANCE	> 1 x 10 ⁹ Ω
MAXIMUM THERMAL OFFSET PER CHANNEL (HI-LO)	< 10 μV
CAPACITANCE	
Open channel	< 58 pF
Channel-mainframe	< 375 pF
High-low	< 390 pF
BANDWIDTH (-3 dB)	
(2) 1 x76 1-Wire Multiplexer	36 MHz (best), 30 MHz (worst)
(2) 1 x38 2-Wire Multiplexer	53 MHz (best), 42 MHz (worst)
(1) 1 x76 2- Wire Multiplexer	25 MHz (best), 20 MHz (worst)
CROSSTALK (TYPICAL) - 2WIRE	
100 KHz	< -66 dB
1 MHz	< -59 dB
ISOLATION (TYPICAL)- 2WIRE	
100 kHz	< -77 dB
1 MHz	< -55 dB
INSERTION LOSS- 2WIRE	
100 kHz	< 0.56 dB
1 MHz	< 0.58 dB
10 MHz	< 0.62 dB

FOR MATING CONNECTOR, CRIMP PINS, AND OTHER ACCESSORIES, PLEASE REFER TO *APPENDIX B*

SMX-3276, MATRIX MODULE

(2) 1 x 76 1-WIRE FIXED MULTIPLEXER

The SMX-3277, PXIe high-density multiplexer modules designed for scanning of multiple points to a common bus, in 1-wire configuration mode. The SMX-3277 consists of two individual (1 x 76) multiplexers.

The SMX-3277 incorporates extensive signal shielding and exposes shield pins on the front panel connector for tying to the cable shield. This preserves signal integrity throughout the signal path by maintaining the signals at the same reference level as the UUT. In addition, meticulous signal routing is done for impedance matching, signal shielding and cross talk reduction, allowing the SMX-3277 to achieve best in class switching performance with a bandwidth of > 30 MHz. This performance allows the card to be used with high frequency signals, and signals that have fast rise times and narrow pulse widths.

CONNECTOR PINS AND SIGNALS

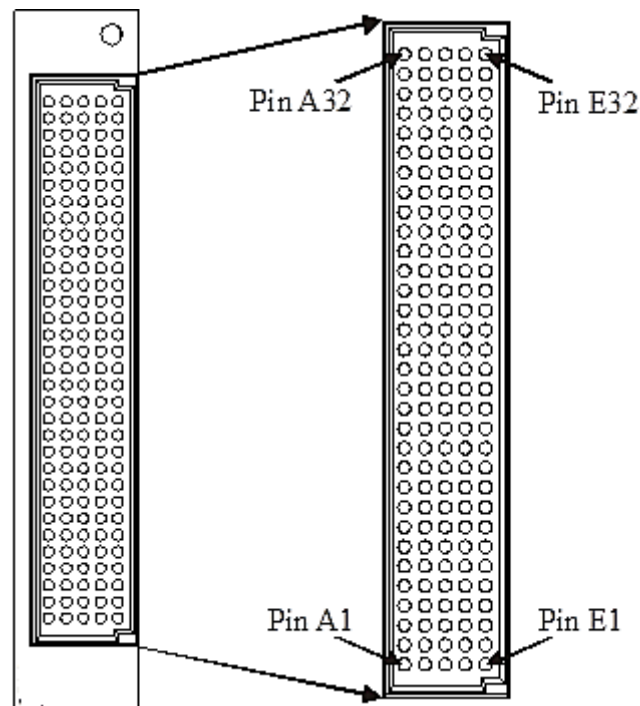

FIGURE 3-45: SMX-3277 FRONT PANEL CONNECTOR (FRONT VIEW)

Row A		Row B		Row C		Row D		Row E	
Pin	Signal	Pin	Signal	Pin	Signal	Pin	Signal	Pin	Signal
1	USR_SHIELD	1	CH1_37L	1	CH1_37H	1	CH1_38L	1	CH1_38H
2	CH1_3L	2	CH1_4L	2	CH1_8L	2	CH1_7L	2	CH1_1L
3	CH1_3H	3	CH1_4H	3	CH1_8H	3	CH1_7H	3	CH1_1H
4	CH1_5L	4	CH1_6L	4	CH1_2L	4	CH1_9L	4	CH1_11L
5	CH1_5H	5	CH1_6H	5	CH1_2H	5	CH1_9H	5	CH1_11H
6	CH1_10L	6	CH1_15L	6	CH1_13L	6	CH1_17L	6	CH1_18L
7	CH1_10H	7	CH1_15H	7	CH1_13H	7	CH1_17H	7	CH1_18H
8	CH1_14L	8	CH1_26L	8	CH1_12L	8	CH1_27L	8	CH1_16L
9	CH1_14H	9	CH1_26H	9	CH1_12H	9	CH1_27H	9	CH1_16H
10	CH1_24L	10	CH1_19L	10	CH1_21L	10	CH1_25L	10	CH1_22L
11	CH1_24H	11	CH1_19H	11	CH1_21H	11	CH1_25H	11	CH1_22H
12	CH1_36L	12	CH1_20L	12	CH1_30L	12	CH1_23L	12	CH1_31L
13	CH1_36H	13	CH1_20H	13	CH1_30H	13	CH1_23H	13	CH1_31H
14	UNUSED	14	CH1_28L	14	CH1_29L	14	CH1_35L	14	CH1_34L
15	CH1_COM_1W	15	CH1_28H	15	CH1_29H	15	CH1_35H	15	CH1_34H
16	CH1_33L	16	CH1_32L	16	CH2_5L	16	CH2_4L	16	UNUSED
17	CH1_33H	17	CH1_32H	17	CH2_5H	17	CH2_4H	17	CH2_COM_1W
18	CH2_1L	18	CH2_8L	18	CH2_3L	18	CH2_2L	18	CH2_9L
19	CH2_1H	19	CH2_8H	19	CH2_3H	19	CH2_2H	19	CH2_9H
20	CH2_7L	20	CH2_14L	20	CH2_13L	20	CH2_6L	20	USR_SHIELD
21	CH2_7H	21	CH2_14H	21	CH2_13H	21	CH2_6H	21	USR_SHIELD
22	CH2_11L	22	CH2_12L	22	CH2_17L	22	CH2_10L	22	CH2_18L
23	CH2_11H	23	CH2_12H	23	CH2_17H	23	CH2_10H	23	CH2_18H
24	CH2_23L	24	CH2_16L	24	CH2_15L	24	CH2_19L	24	CH2_22L
25	CH2_23H	25	CH2_16H	25	CH2_15H	25	CH2_19H	25	CH2_22H
26	CH2_27L	26	CH2_20L	26	CH2_26L	26	CH2_29L	26	CH2_21L
27	CH2_27H	27	CH2_20H	27	CH2_26H	27	CH2_29H	27	CH2_21H
28	CH2_30L	28	CH2_25L	28	CH2_34L	28	CH2_24L	28	CH2_32L
29	CH2_30H	29	CH2_25H	29	CH2_34H	29	CH2_24H	29	CH2_32H
30	CH2_31L	30	CH2_33L	30	CH2_28L	30	CH2_36L	30	CH2_35L
31	CH2_31H	31	CH2_33H	31	CH2_28H	31	CH2_36H	31	CH2_35H
32	USR_SHIELD	32	CH2_37L	32	CH2_37H	32	CH2_38L	32	CH2_38H

TABLE 3-21: SMX-3277 CONNECTOR PINS & SIGNAL ASSIGNMENTS

LOGICAL DIAGRAM

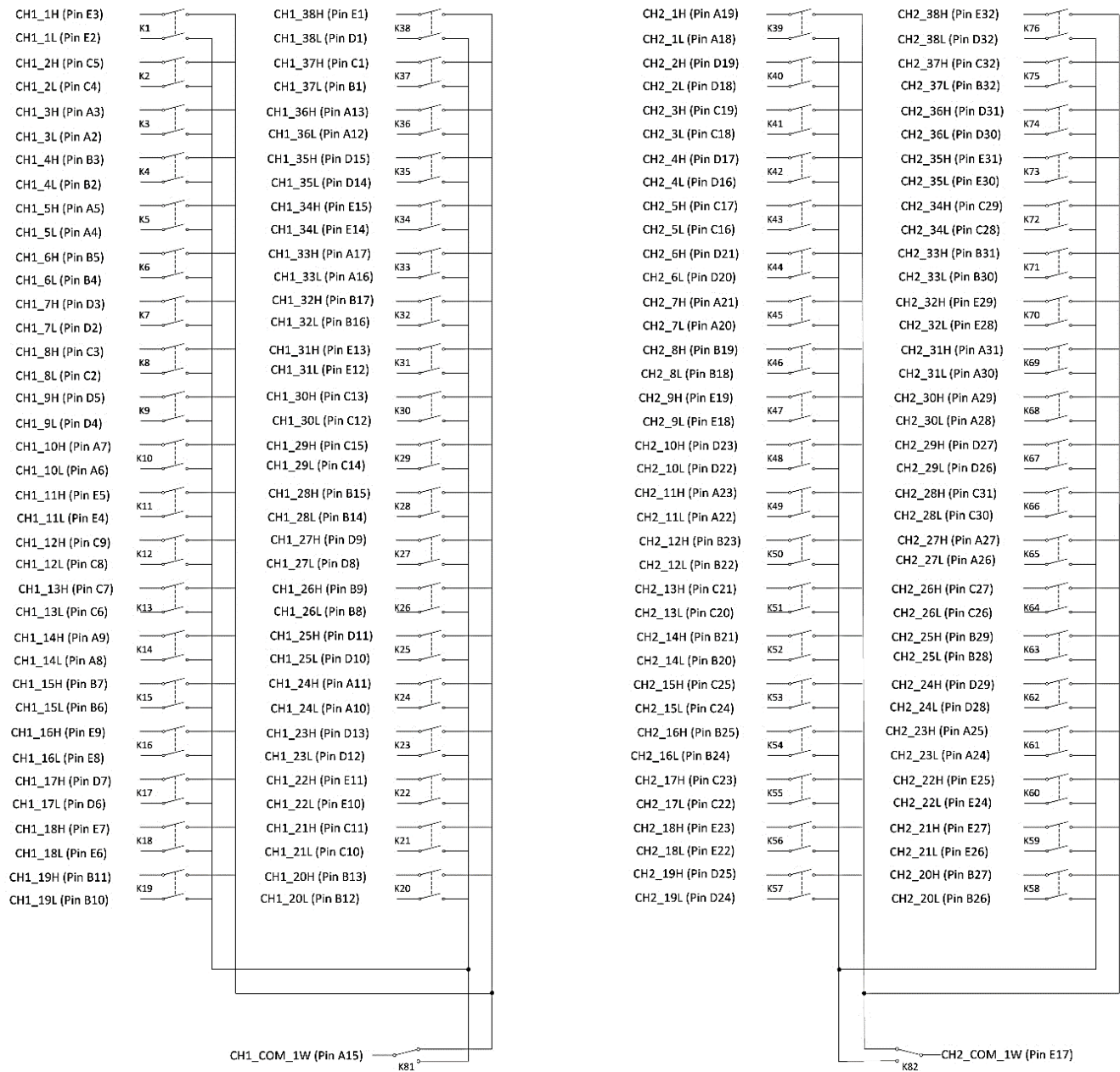

FIGURE 3-46: SMX-3277 LOGICAL DIAGRAM

SMX-3277 SPECIFICATIONS

GENERAL SPECIFICATIONS	
CHANNEL COUNT	(2) 1x76 1-wire Multiplexer
RELAY TYPE	Electromechanical, fail-safe
MAXIMUM SWITCHING VOLTAGE	300 V dc, 300 V ac
MAXIMUM SWITCHING CURRENT	2 A
MAXIMUM SWITCHING POWER	60 W dc, 62.5 VA
<i>*Maximum switched power is at 30 V/ 2 A dc. Max switched power is derated non-linearly as voltage is increased.</i>	
RATED SWITCH OPERATIONS	
Mechanical	1 x 10 ⁸ (no load)
Electrical	Min. 1 x 10 ⁵ @ (resistive load, 250VAC/0.25A), (resistive load, 30VDC/2A)
SWITCHING TIME	< 8 ms
PATH RESISTANCE	< 500 mΩ
INSULATION RESISTANCE	> 1 x 10 ⁹ Ω
MAXIMUM THERMAL OFFSET PER CHANNEL (HI-LO)	< 10 μV
CAPACITANCE	
Open channel	< 37 pF
Channel-mainframe	< 200 pF
High-low	< 196 pF
BANDWIDTH (-3 dB)	37 MHz (best), 36 MHz (worst)
CROSSTALK (TYPICAL)	
100 KHz	< -70 dB
1 MHz	< -51 dB
ISOLATION (TYPICAL)	
100 kHz	< -72 dB
1 MHz	< -45 dB
INSERTION LOSS	
100 kHz	< 0.26 dB
1 MHz	< 0.33 dB
10 MHz	< 1.22 dB

FOR MATING CONNECTOR, CRIMP PINS, AND OTHER ACCESSORIES, PLEASE REFER TO *APPENDIX B*

SMX-3276, MATRIX MODULE

(2) 1 x 76 1-WIRE FIXED MULTIPLEXER

The SMX-3277DS, PXIe high-density multiplexer modules designed for scanning of multiple points to a common bus, in 1-wire configuration mode. The SMX-3277DS consists of two individual (1 x 76) multiplexers.

In contrast to the SMX-3277 the SMX-3277DS has internal residual voltage discharge relays that can be enabled to momentarily short out the measurement path when changing from one input channel to the next. This dissipates any voltage held by the wiring and instrument input capacitance. These relays protect sensitive devices, such as CMOS circuits, from residual voltages caused by previous high-voltage measurements. This feature can also be disabled in low-voltage applications where maximum throughput speed is important.

The SMX-3277DS incorporates extensive signal shielding and exposes shield pins on the front panel connector for tying to the cable shield. This preserves signal integrity throughout the signal path by maintaining the signals at the same reference level as the UUT. In addition, meticulous signal routing is done for impedance matching, signal shielding and cross talk reduction, allowing the SMX-3277DS to achieve best in class switching performance with a bandwidth of > 30 MHz. This performance allows the card to be used with high frequency signals, and signals that have fast rise times and narrow pulse widths.

NOTE SMX-3277DS where DS stands for DISCHARGE relays support

CONNECTOR PINS AND SIGNALS

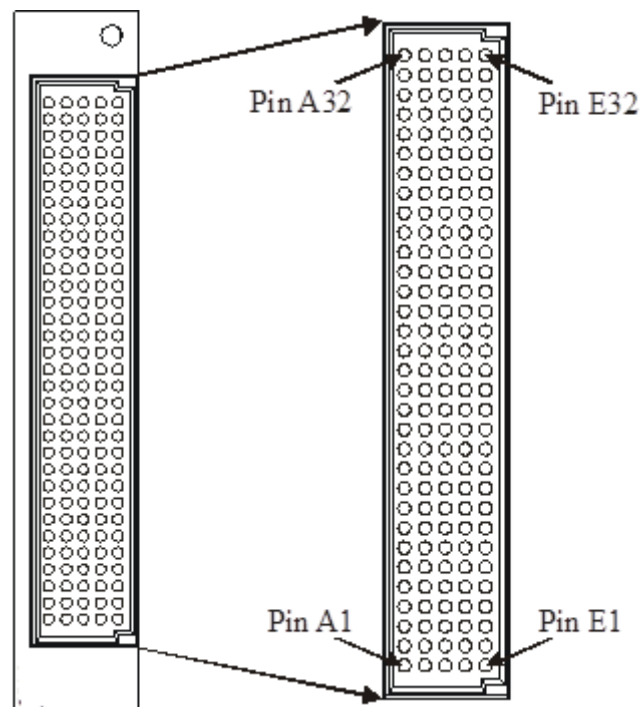

FIGURE 3-47: SMX-3277DS FRONT PANEL CONNECTOR (FRONT VIEW)

Row A		Row B		Row C		Row D		Row E	
Pin	Signal	Pin	Signal	Pin	Signal	Pin	Signal	Pin	Signal
1	USR_SHIELD	1	CH1_37L	1	CH1_37H	1	CH1_38L	1	CH1_38H
2	CH1_3L	2	CH1_4L	2	CH1_8L	2	CH1_7L	2	CH1_1L
3	CH1_3H	3	CH1_4H	3	CH1_8H	3	CH1_7H	3	CH1_1H
4	CH1_5L	4	CH1_6L	4	CH1_2L	4	CH1_9L	4	CH1_11L
5	CH1_5H	5	CH1_6H	5	CH1_2H	5	CH1_9H	5	CH1_11H
6	CH1_10L	6	CH1_15L	6	CH1_13L	6	CH1_17L	6	CH1_18L
7	CH1_10H	7	CH1_15H	7	CH1_13H	7	CH1_17H	7	CH1_18H
8	CH1_14L	8	CH1_26L	8	CH1_12L	8	CH1_27L	8	CH1_16L
9	CH1_14H	9	CH1_26H	9	CH1_12H	9	CH1_27H	9	CH1_16H
10	CH1_24L	10	CH1_19L	10	CH1_21L	10	CH1_25L	10	CH1_22L
11	CH1_24H	11	CH1_19H	11	CH1_21H	11	CH1_25H	11	CH1_22H
12	CH1_36L	12	CH1_20L	12	CH1_30L	12	CH1_23L	12	CH1_31L
13	CH1_36H	13	CH1_20H	13	CH1_30H	13	CH1_23H	13	CH1_31H
14	UNUSED	14	CH1_28L	14	CH1_29L	14	CH1_35L	14	CH1_34L
15	CH1_COM_1W	15	CH1_28H	15	CH1_29H	15	CH1_35H	15	CH1_34H
16	CH1_33L	16	CH1_32L	16	CH2_5L	16	CH2_4L	16	UNUSED
17	CH1_33H	17	CH1_32H	17	CH2_5H	17	CH2_4H	17	CH2_COM_1W
18	CH2_1L	18	CH2_8L	18	CH2_3L	18	CH2_2L	18	CH2_9L
19	CH2_1H	19	CH2_8H	19	CH2_3H	19	CH2_2H	19	CH2_9H
20	CH2_7L	20	CH2_14L	20	CH2_13L	20	CH2_6L	20	USR_SHIELD
21	CH2_7H	21	CH2_14H	21	CH2_13H	21	CH2_6H	21	USR_SHIELD
22	CH2_11L	22	CH2_12L	22	CH2_17L	22	CH2_10L	22	CH2_18L
23	CH2_11H	23	CH2_12H	23	CH2_17H	23	CH2_10H	23	CH2_18H
24	CH2_23L	24	CH2_16L	24	CH2_15L	24	CH2_19L	24	CH2_22L
25	CH2_23H	25	CH2_16H	25	CH2_15H	25	CH2_19H	25	CH2_22H
26	CH2_27L	26	CH2_20L	26	CH2_26L	26	CH2_29L	26	CH2_21L
27	CH2_27H	27	CH2_20H	27	CH2_26H	27	CH2_29H	27	CH2_21H
28	CH2_30L	28	CH2_25L	28	CH2_34L	28	CH2_24L	28	CH2_32L
29	CH2_30H	29	CH2_25H	29	CH2_34H	29	CH2_24H	29	CH2_32H
30	CH2_31L	30	CH2_33L	30	CH2_28L	30	CH2_36L	30	CH2_35L
31	CH2_31H	31	CH2_33H	31	CH2_28H	31	CH2_36H	31	CH2_35H
32	USR_SHIELD	32	CH2_37L	32	CH2_37H	32	CH2_38L	32	CH2_38H

TABLE 3-22: SMX-3277DS CONNECTOR PINS & SIGNAL ASSIGNMENTS

LOGICAL DIAGRAM

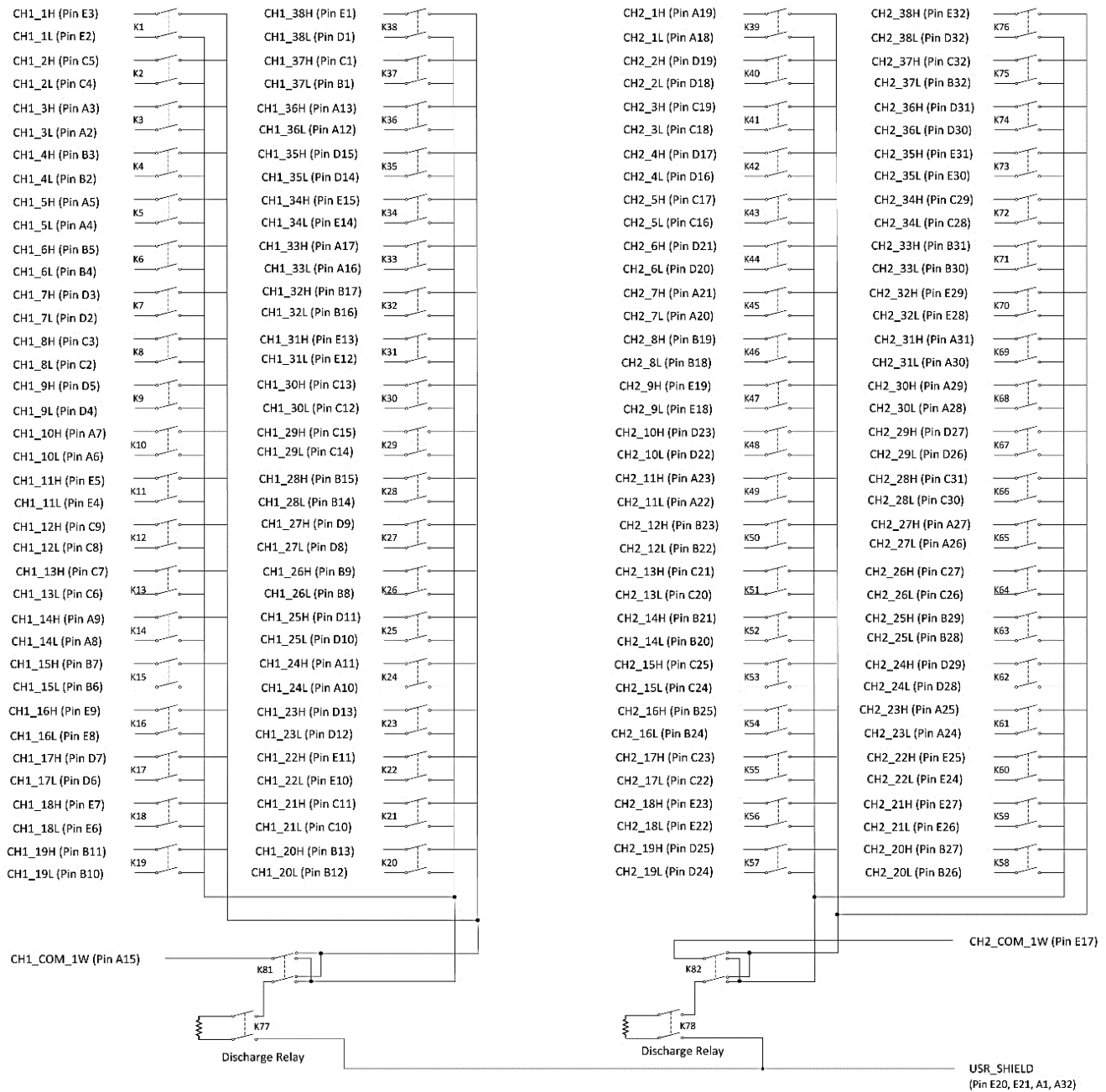

FIGURE 3-48: SMX-3277DS LOGICAL DIAGRAM

SMX-3277DS SPECIFICATIONS

GENERAL SPECIFICATIONS	
CHANNEL COUNT	(2) 1x76 1-wire Multiplexer
RELAY TYPE	Electromechanical, fail-safe
MAXIMUM SWITCHING VOLTAGE	300 V dc, 300 V ac
MAXIMUM SWITCHING CURRENT	2 A
MAXIMUM SWITCHING POWER	60 W dc, 62.5 VA
<i>*Maximum switched power is at 30 V/ 2 A dc. Max switched power is derated non-linearly as voltage is increased.</i>	
RATED SWITCH OPERATIONS	
Mechanical	1 x 10 ⁸ (no load)
Electrical	Min. 1 x 10 ⁵ @ (resistive load, 250VAC/0.25A), (resistive load, 30VDC/2A)
SWITCHING TIME	< 8 ms
PATH RESISTANCE	< 500 mΩ
INSULATION RESISTANCE	> 1 x 10 ⁹ Ω
MAXIMUM THERMAL OFFSET PER CHANNEL (HI-LO)	
	< 10 μV
CAPACITANCE	
Open channel	< 37 pF
Channel-mainframe	< 200 pF
High-low	< 196 pF
BANDWIDTH (-3 dB)	37 MHz (best), 36 MHz (worst)
CROSSTALK (TYPICAL)	
100 KHz	< -70 dB
1 MHz	< -51 dB
ISOLATION (TYPICAL)	
100 kHz	< -72 dB
1 MHz	< -45 dB
INSERTION LOSS	
100 kHz	< 0.26 dB
1 MHz	< 0.33 dB
10 MHz	< 1.22 dB

FOR MATING CONNECTOR, CRIMP PINS, AND OTHER ACCESSORIES, PLEASE REFER TO *APPENDIX B*

SMX-3276, MATRIX MODULE

(2) 1 x 38 2-WIRE FIXED MULTIPLEXER

The SMX-3278, PXIe high-density multiplexer modules designed for scanning of multiple points to a common bus, in 2-wire configuration mode. The SMX-3278 consists of two individual (1 x 38) multiplexers.

The SMX-3278 incorporates extensive signal shielding and exposes shield pins on the front panel connector for tying to the cable shield. This preserves signal integrity throughout the signal path by maintaining the signals at the same reference level as the UUT. In addition, meticulous signal routing is done for impedance matching, signal shielding and cross talk reduction, allowing the SMX-3278 to achieve best in class switching performance with a bandwidth of > 40 MHz. This performance allows the card to be used with high frequency signals, and signals that have fast rise times and narrow pulse widths.

CONNECTOR PINS AND SIGNALS

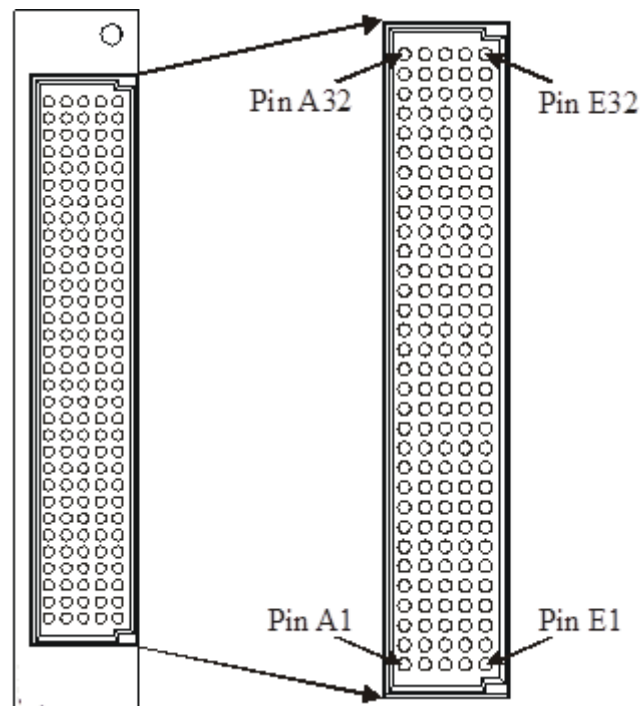

FIGURE 3-49: SMX-3278 FRONT PANEL CONNECTOR (FRONT VIEW)

Row A		Row B		Row C		Row D		Row E	
Pin	Signal	Pin	Signal	Pin	Signal	Pin	Signal	Pin	Signal
1	USR_SHIELD	1	CH1_37L	1	CH1_37H	1	CH1_38L	1	CH1_38H
2	CH1_3L	2	CH1_4L	2	CH1_8L	2	CH1_7L	2	CH1_1L
3	CH1_3H	3	CH1_4H	3	CH1_8H	3	CH1_7H	3	CH1_1H
4	CH1_5L	4	CH1_6L	4	CH1_2L	4	CH1_9L	4	CH1_11L
5	CH1_5H	5	CH1_6H	5	CH1_2H	5	CH1_9H	5	CH1_11H
6	CH1_10L	6	CH1_15L	6	CH1_13L	6	CH1_17L	6	CH1_18L
7	CH1_10H	7	CH1_15H	7	CH1_13H	7	CH1_17H	7	CH1_18H
8	CH1_14L	8	CH1_26L	8	CH1_12L	8	CH1_27L	8	CH1_16L
9	CH1_14H	9	CH1_26H	9	CH1_12H	9	CH1_27H	9	CH1_16H
10	CH1_24L	10	CH1_19L	10	CH1_21L	10	CH1_25L	10	CH1_22L
11	CH1_24H	11	CH1_19H	11	CH1_21H	11	CH1_25H	11	CH1_22H
12	CH1_36L	12	CH1_20L	12	CH1_30L	12	CH1_23L	12	CH1_31L
13	CH1_36H	13	CH1_20H	13	CH1_30H	13	CH1_23H	13	CH1_31H
14	CH1_COM L	14	CH1_28L	14	CH1_29L	14	CH1_35L	14	CH1_34L
15	CH1_COMH	15	CH1_28H	15	CH1_29H	15	CH1_35H	15	CH1_34H
16	CH1_33L	16	CH1_32L	16	CH2_5L	16	CH2_4L	16	CH2_COM L
17	CH1_33H	17	CH1_32H	17	CH2_5H	17	CH2_4H	17	CH2_COMH
18	CH2_1L	18	CH2_8L	18	CH2_3L	18	CH2_2L	18	CH2_9L
19	CH2_1H	19	CH2_8H	19	CH2_3H	19	CH2_2H	19	CH2_9H
20	CH2_7L	20	CH2_14L	20	CH2_13L	20	CH2_6L	20	USR_SHIELD
21	CH2_7H	21	CH2_14H	21	CH2_13H	21	CH2_6H	21	USR_SHIELD
22	CH2_11L	22	CH2_12L	22	CH2_17L	22	CH2_10L	22	CH2_18L
23	CH2_11H	23	CH2_12H	23	CH2_17H	23	CH2_10H	23	CH2_18H
24	CH2_23L	24	CH2_16L	24	CH2_15L	24	CH2_19L	24	CH2_22L
25	CH2_23H	25	CH2_16H	25	CH2_15H	25	CH2_19H	25	CH2_22H
26	CH2_27L	26	CH2_20L	26	CH2_26L	26	CH2_29L	26	CH2_21L
27	CH2_27H	27	CH2_20H	27	CH2_26H	27	CH2_29H	27	CH2_21H
28	CH2_30L	28	CH2_25L	28	CH2_34L	28	CH2_24L	28	CH2_32L
29	CH2_30H	29	CH2_25H	29	CH2_34H	29	CH2_24H	29	CH2_32H
30	CH2_31L	30	CH2_33L	30	CH2_28L	30	CH2_36L	30	CH2_35L
31	CH2_31H	31	CH2_33H	31	CH2_28H	31	CH2_36H	31	CH2_35H
32	USR_SHIELD	32	CH2_37L	32	CH2_37H	32	CH2_38L	32	CH2_38H

TABLE 3-23: SMX-3278 CONNECTOR PINS & SIGNAL ASSIGNMENTS

LOGICAL DIAGRAM

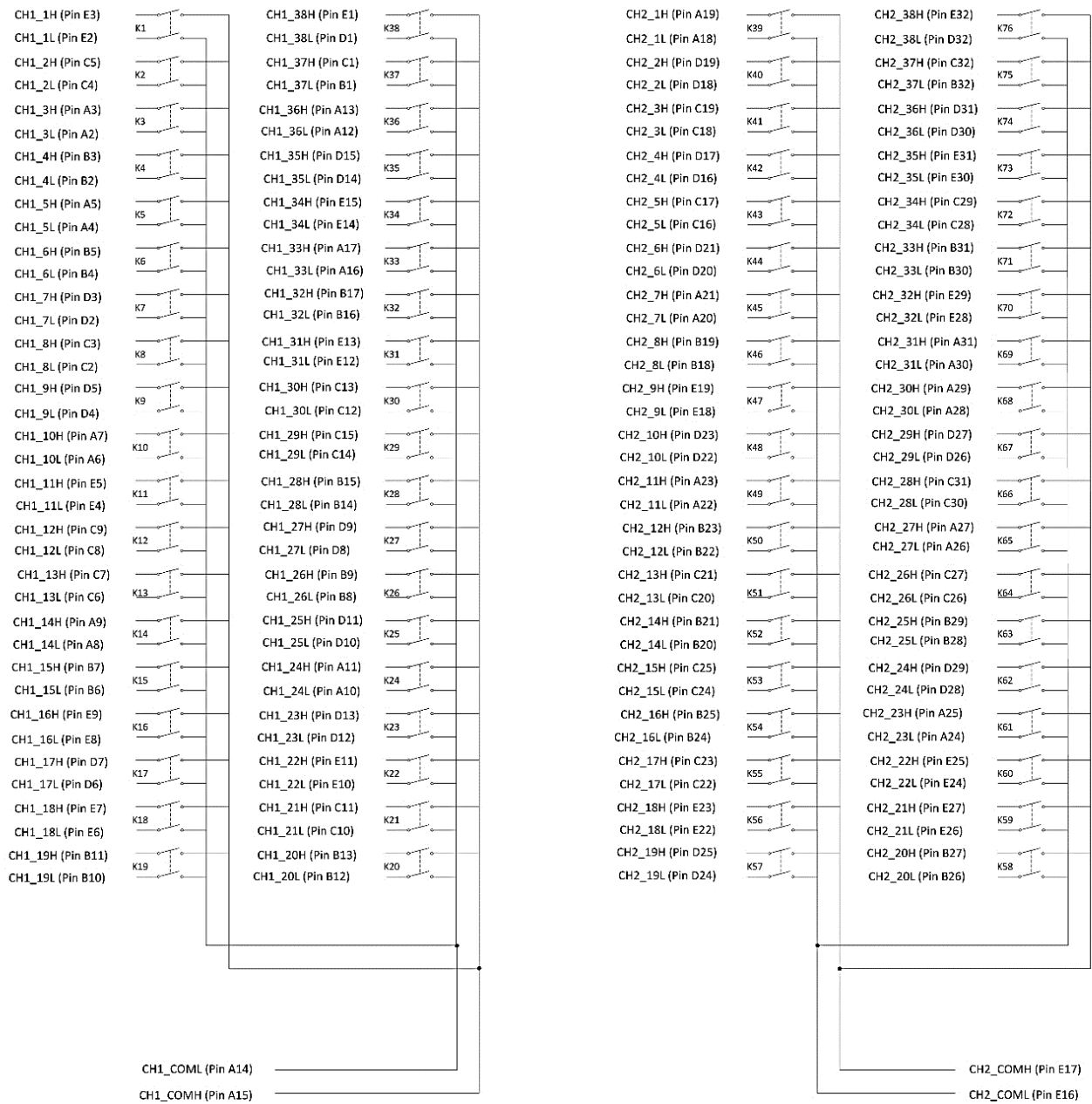

FIGURE 3-50: SMX-3278 LOGICAL DIAGRAM

SMX-3278 SPECIFICATIONS

GENERAL SPECIFICATIONS	
CHANNEL COUNT	(2) 1x38 2-wire Multiplexer
RELAY TYPE	Electromechanical, fail-safe
MAXIMUM SWITCHING VOLTAGE	300 V dc, 300 V ac
MAXIMUM SWITCHING CURRENT	2 A
MAXIMUM SWITCHING POWER	60 W dc, 62.5 VA
<i>*Maximum switched power is at 30 V/ 2 A dc. Max switched power is derated non-linearly as voltage is increased.</i>	
RATED SWITCH OPERATIONS	
Mechanical	1 x 10 ⁸ (no load)
Electrical	Min. 1 x 10 ⁵ @ (resistive load, 250VAC/0.25A), (resistive load, 30VDC/2A)
SWITCHING TIME	< 8 ms
PATH RESISTANCE	< 500 mΩ
INSULATION RESISTANCE	> 1 x 10 ⁹ Ω
MAXIMUM THERMAL OFFSET PER CHANNEL (HI-LO)	< 10 μV
CAPACITANCE	
Open channel	< 37 pF
Channel-mainframe	< 220 pF
High-low	< 226 pF
BANDWIDTH (-3 dB)	45 MHz (typical), 54 MHz (best), 43 MHz (worst)
CROSSTALK (TYPICAL)	
100 KHz	< -66 dB
1 MHz	< -59 dB
ISOLATION (TYPICAL)	
100 kHz	< -78 dB
1 MHz	< -53 dB
INSERTION LOSS	
100 kHz	< 0.16 dB
1 MHz	< 0.18 dB
10 MHz	< 0.32 dB

FOR MATING CONNECTOR, CRIMP PINS, AND OTHER ACCESSORIES, PLEASE REFER TO *APPENDIX B*

SMX-3276, MATRIX MODULE

(2) 1 x 38 2-WIRE FIXED MULTIPLEXER

The SMX-3278DS, PXIe high-density multiplexer modules designed for scanning of multiple points to a common bus, in 2-wire configuration mode. The SMX-3278DS consists of two individual (1 x 38) multiplexers.

In contrast to the SMX-3278 the SMX-3278DS has internal residual voltage discharge relays that can be enabled to momentarily short out the measurement path when changing from one input channel to the next. This dissipates any voltage held by the wiring and instrument input capacitance. These relays protect sensitive devices, such as CMOS circuits, from residual voltages caused by previous high-voltage measurements. This feature can also be disabled in low-voltage applications where maximum throughput speed is important.

The SMX-3278DS incorporates extensive signal shielding and exposes shield pins on the front panel connector for tying to the cable shield. This preserves signal integrity throughout the signal path by maintaining the signals at the same reference level as the UUT. In addition, meticulous signal routing is done for impedance matching, signal shielding and cross talk reduction, allowing the SMX-3278DS to achieve best in class switching performance with a bandwidth of > 40 MHz. This performance allows the card to be used with high frequency signals, and signals that have fast rise times and narrow pulse widths.

NOTE SMX-3278DS where DS stands for DISCHARGE relays support

CONNECTOR PINS AND SIGNALS

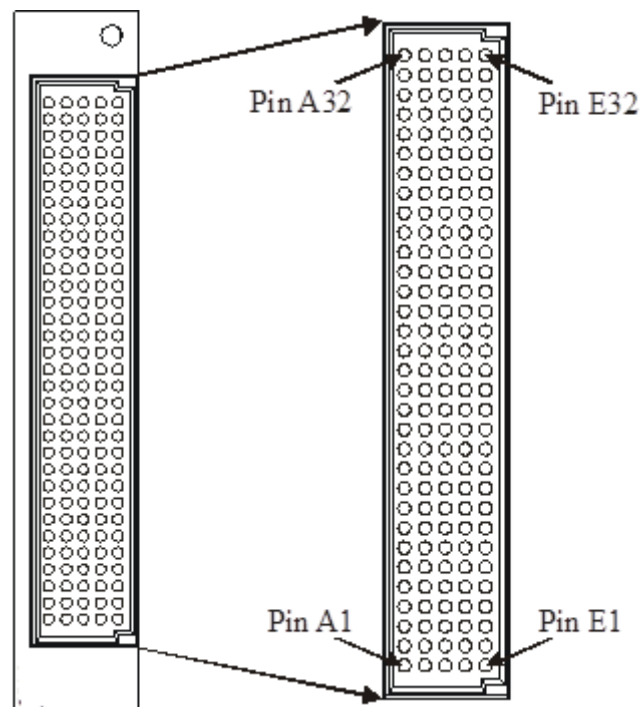

FIGURE 3-51: SMX-3278DS FRONT PANEL CONNECTOR (FRONT VIEW)

Row A		Row B		Row C		Row D		Row E	
Pin	Signal	Pin	Signal	Pin	Signal	Pin	Signal	Pin	Signal
1	USR_SHIELD	1	CH1_37L	1	CH1_37H	1	CH1_38L	1	CH1_38H
2	CH1_3L	2	CH1_4L	2	CH1_8L	2	CH1_7L	2	CH1_1L
3	CH1_3H	3	CH1_4H	3	CH1_8H	3	CH1_7H	3	CH1_1H
4	CH1_5L	4	CH1_6L	4	CH1_2L	4	CH1_9L	4	CH1_11L
5	CH1_5H	5	CH1_6H	5	CH1_2H	5	CH1_9H	5	CH1_11H
6	CH1_10L	6	CH1_15L	6	CH1_13L	6	CH1_17L	6	CH1_18L
7	CH1_10H	7	CH1_15H	7	CH1_13H	7	CH1_17H	7	CH1_18H
8	CH1_14L	8	CH1_26L	8	CH1_12L	8	CH1_27L	8	CH1_16L
9	CH1_14H	9	CH1_26H	9	CH1_12H	9	CH1_27H	9	CH1_16H
10	CH1_24L	10	CH1_19L	10	CH1_21L	10	CH1_25L	10	CH1_22L
11	CH1_24H	11	CH1_19H	11	CH1_21H	11	CH1_25H	11	CH1_22H
12	CH1_36L	12	CH1_20L	12	CH1_30L	12	CH1_23L	12	CH1_31L
13	CH1_36H	13	CH1_20H	13	CH1_30H	13	CH1_23H	13	CH1_31H
14	CH1_COM L	14	CH1_28L	14	CH1_29L	14	CH1_35L	14	CH1_34L
15	CH1_COMH	15	CH1_28H	15	CH1_29H	15	CH1_35H	15	CH1_34H
16	CH1_33L	16	CH1_32L	16	CH2_5L	16	CH2_4L	16	CH2_COM L
17	CH1_33H	17	CH1_32H	17	CH2_5H	17	CH2_4H	17	CH2_COMH
18	CH2_1L	18	CH2_8L	18	CH2_3L	18	CH2_2L	18	CH2_9L
19	CH2_1H	19	CH2_8H	19	CH2_3H	19	CH2_2H	19	CH2_9H
20	CH2_7L	20	CH2_14L	20	CH2_13L	20	CH2_6L	20	USR_SHIELD
21	CH2_7H	21	CH2_14H	21	CH2_13H	21	CH2_6H	21	USR_SHIELD
22	CH2_11L	22	CH2_12L	22	CH2_17L	22	CH2_10L	22	CH2_18L
23	CH2_11H	23	CH2_12H	23	CH2_17H	23	CH2_10H	23	CH2_18H
24	CH2_23L	24	CH2_16L	24	CH2_15L	24	CH2_19L	24	CH2_22L
25	CH2_23H	25	CH2_16H	25	CH2_15H	25	CH2_19H	25	CH2_22H
26	CH2_27L	26	CH2_20L	26	CH2_26L	26	CH2_29L	26	CH2_21L
27	CH2_27H	27	CH2_20H	27	CH2_26H	27	CH2_29H	27	CH2_21H
28	CH2_30L	28	CH2_25L	28	CH2_34L	28	CH2_24L	28	CH2_32L
29	CH2_30H	29	CH2_25H	29	CH2_34H	29	CH2_24H	29	CH2_32H
30	CH2_31L	30	CH2_33L	30	CH2_28L	30	CH2_36L	30	CH2_35L
31	CH2_31H	31	CH2_33H	31	CH2_28H	31	CH2_36H	31	CH2_35H
32	USR_SHIELD	32	CH2_37L	32	CH2_37H	32	CH2_38L	32	CH2_38H

TABLE 3-24: SMX-3278DS CONNECTOR PINS & SIGNAL ASSIGNMENTS

LOGICAL DIAGRAM

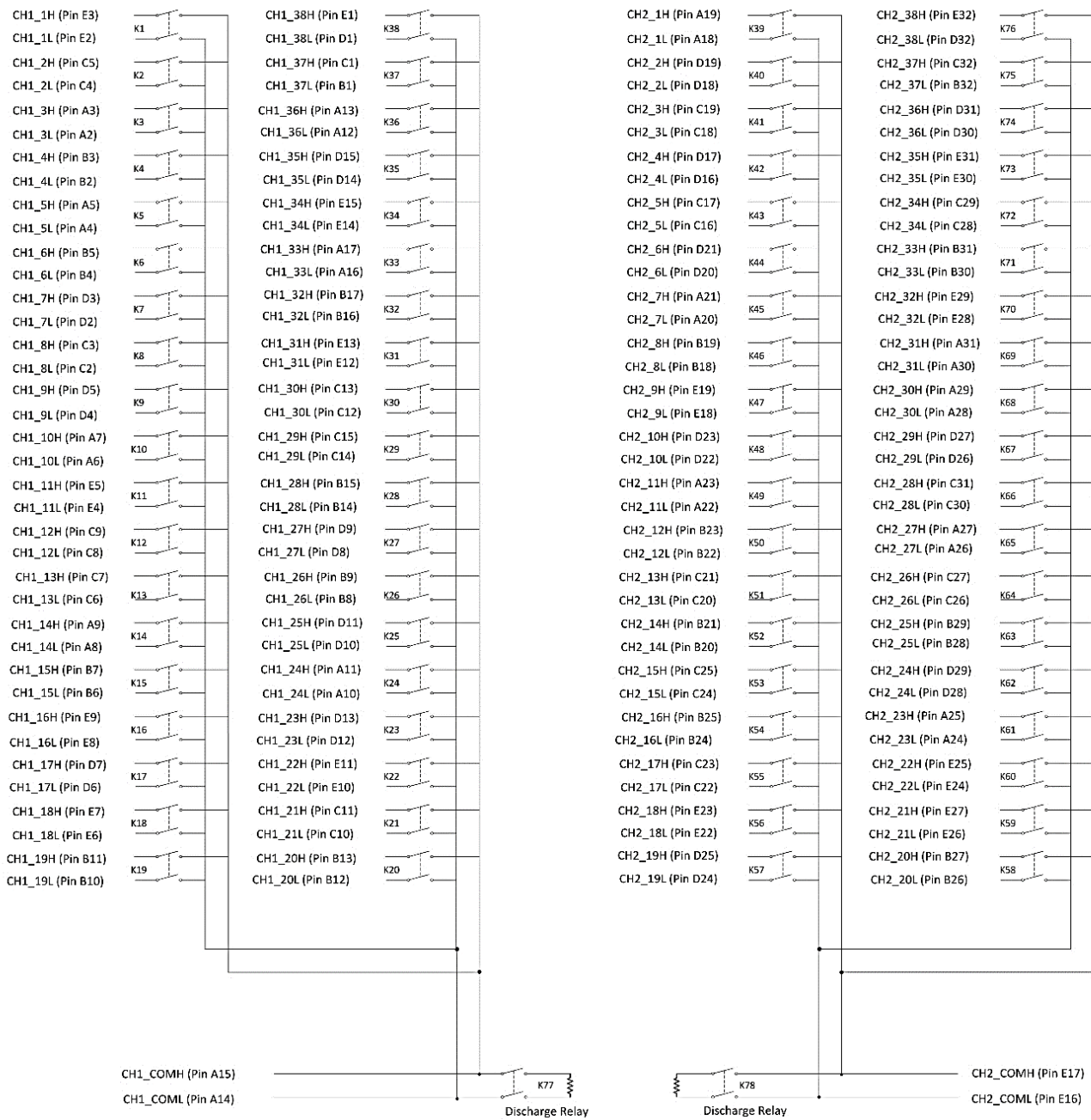

FIGURE 3-52: SMX-3278DS LOGICAL DIAGRAM

SMX-3278DS SPECIFICATIONS

GENERAL SPECIFICATIONS	
CHANNEL COUNT	(2) 1x38 2-wire Multiplexer
RELAY TYPE	Electromechanical, fail-safe
MAXIMUM SWITCHING VOLTAGE	300 V dc, 300 V ac
MAXIMUM SWITCHING CURRENT	2 A
MAXIMUM SWITCHING POWER	60 W dc, 62.5 VA
<i>*Maximum switched power is at 30 V/ 2 A dc. Max switched power is derated non-linearly as voltage is increased.</i>	
RATED SWITCH OPERATIONS	
Mechanical	1 x 10 ⁸ (no load)
Electrical	Min. 1 x 10 ⁵ @ (resistive load, 250VAC/0.25A), (resistive load, 30VDC/2A)
SWITCHING TIME	< 8 ms
PATH RESISTANCE	< 500 mΩ
INSULATION RESISTANCE	> 1 x 10 ⁹ Ω
MAXIMUM THERMAL OFFSET PER CHANNEL (HI-LO)	
	< 10 μV
CAPACITANCE	
Open channel	< 37 pF
Channel-mainframe	< 220 pF
High-low	< 226 pF
BANDWIDTH (-3 dB)	45 MHz (typical), 54 MHz (best), 43 MHz (worst)
CROSSTALK (TYPICAL)	
100 KHz	< -66 dB
1 MHz	< -59 dB
ISOLATION (TYPICAL)	
100 kHz	< -78 dB
1 MHz	< -53 dB
INSERTION LOSS	
100 kHz	< 0.16 dB
1 MHz	< 0.18 dB
10 MHz	< 0.32 dB

FOR MATING CONNECTOR, CRIMP PINS, AND OTHER ACCESSORIES, PLEASE REFER TO *APPENDIX B*

SMX-3276, MATRIX MODULE

(1) 1 x 76 2-WIRE FIXED MULTIPLEXER

The SMX-3279, PXIe high-density multiplexer modules designed for scanning of multiple points to a common bus, in 2-wire configuration mode. The SMX-3279 consists of one (1 x 76) multiplexer.

The SMX-3279 incorporates extensive signal shielding and exposes shield pins on the front panel connector for tying to the cable shield. This preserves signal integrity throughout the signal path by maintaining the signals at the same reference level as the UUT. In addition, meticulous signal routing is done for impedance matching, signal shielding and cross talk reduction, allowing the SMX-3279 to achieve best in class switching performance with a bandwidth of > 20 MHz. This performance allows the card to be used with high frequency signals, and signals that have fast rise times and narrow pulse widths.

CONNECTOR PINS AND SIGNALS

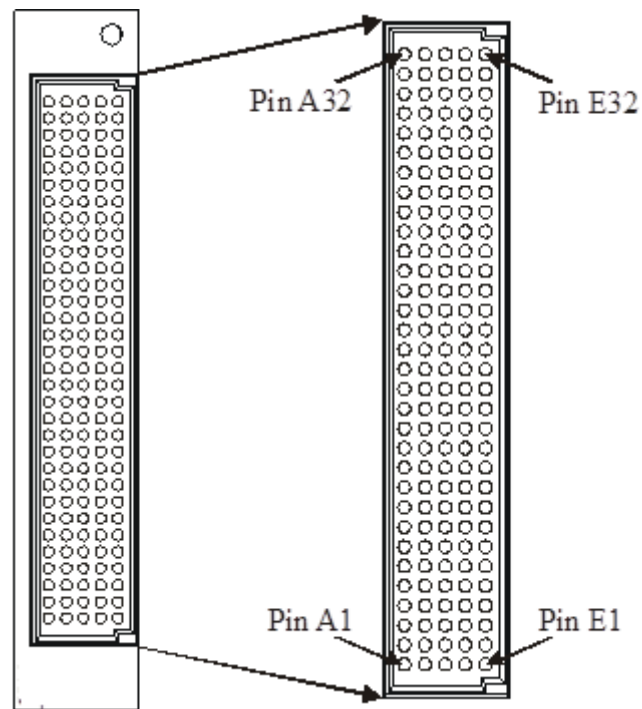

FIGURE 3-53: SMX-3279 FRONT PANEL CONNECTOR (FRONT VIEW)

Row A		Row B		Row C		Row D		Row E	
Pin	Signal	Pin	Signal	Pin	Signal	Pin	Signal	Pin	Signal
1	USR_SHIELD	1	CH_37L	1	CH_37H	1	CH_38L	1	CH_38H
2	CH_3L	2	CH_4L	2	CH_8L	2	CH_7L	2	CH_1L
3	CH_3H	3	CH_4H	3	CH_8H	3	CH_7H	3	CH_1H
4	CH_5L	4	CH_6L	4	CH_2L	4	CH_9L	4	CH_11L
5	CH_5H	5	CH_6H	5	CH_2H	5	CH_9H	5	CH_11H
6	CH_10L	6	CH_15L	6	CH_13L	6	CH_17L	6	CH_18L
7	CH_10H	7	CH_15H	7	CH_13H	7	CH_17H	7	CH_18H
8	CH_14L	8	CH_26L	8	CH_12L	8	CH_27L	8	CH_16L
9	CH_14H	9	CH_26H	9	CH_12H	9	CH_27H	9	CH_16H
10	CH_24L	10	CH_19L	10	CH_21L	10	CH_25L	10	CH_22L
11	CH_24H	11	CH_19H	11	CH_21H	11	CH_25H	11	CH_22H
12	CH_36L	12	CH_20L	12	CH_30L	12	CH_23L	12	CH_31L
13	CH_36H	13	CH_20H	13	CH_30H	13	CH_23H	13	CH_31H
14	CH_COML	14	CH_28L	14	CH_29L	14	CH_35L	14	CH_34L
15	CH_COMH	15	CH_28H	15	CH_29H	15	CH_35H	15	CH_34H
16	CH_33L	16	CH_32L	16	CH_43L	16	CH_42L	16	UNUSED
17	CH_33H	17	CH_32H	17	CH_43H	17	CH_42H	17	UNUSED
18	CH_39L	18	CH_46L	18	CH_41L	18	CH_40L	18	CH_47L
19	CH_39H	19	CH_46H	19	CH_41H	19	CH_40H	19	CH_47H
20	CH_45L	20	CH_52L	20	CH_51L	20	CH_44L	20	USR_SHIELD
21	CH_45H	21	CH_52H	21	CH_51H	21	CH_44H	21	USR_SHIELD
22	CH_49L	22	CH_50L	22	CH_55L	22	CH_48L	22	CH_56L
23	CH_49H	23	CH_50H	23	CH_55H	23	CH_48H	23	CH_56H
24	CH_61L	24	CH_54L	24	CH_53L	24	CH_57L	24	CH_60L
25	CH_61H	25	CH_54H	25	CH_53H	25	CH_57H	25	CH_60H
26	CH_65L	26	CH_58L	26	CH_64L	26	CH_67L	26	CH_59L
27	CH_65H	27	CH_58H	27	CH_64H	27	CH_67H	27	CH_59H
28	CH_68L	28	CH_63L	28	CH_72L	28	CH_62L	28	CH_70L
29	CH_68H	29	CH_63H	29	CH_72H	29	CH_62H	29	CH_70H
30	CH_69L	30	CH_71L	30	CH_66L	30	CH_74L	30	CH_73L
31	CH_69H	31	CH_71H	31	CH_66H	31	CH_74H	31	CH_73H
32	USR_SHIELD	32	CH_75L	32	CH_75H	32	CH_76L	32	CH_76H

TABLE 3-25: SMX-3279 CONNECTOR PINS & SIGNAL ASSIGNMENTS

LOGICAL DIAGRAM

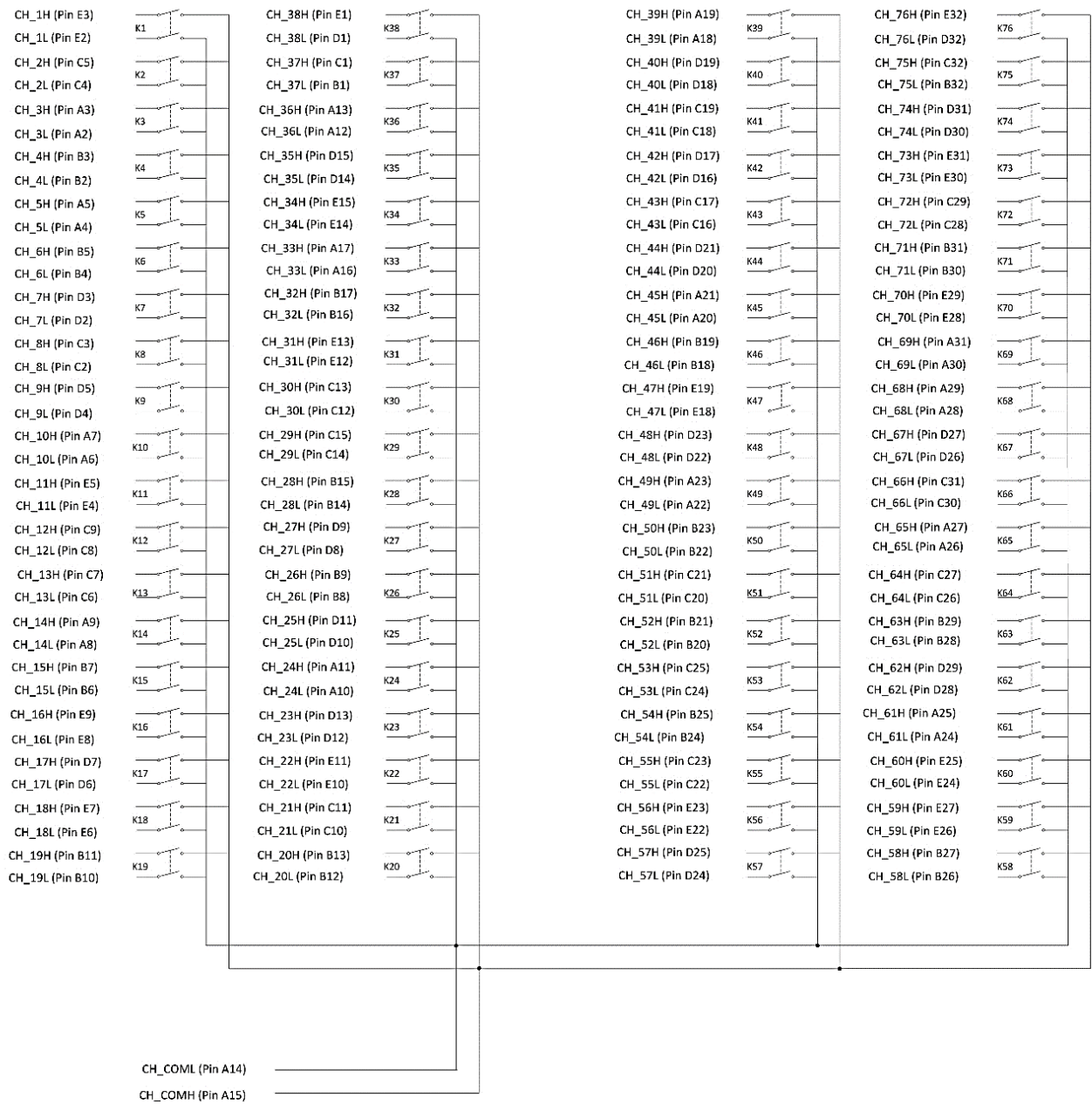

FIGURE 3-54: SMX-3279 LOGICAL DIAGRAM

SMX-3279 SPECIFICATIONS

GENERAL SPECIFICATIONS	
CHANNEL COUNT	(1) 1x76 2-wire Multiplexer
RELAY TYPE	Electromechanical, fail-safe
MAXIMUM SWITCHING VOLTAGE	300 V dc, 300 V ac
MAXIMUM SWITCHING CURRENT	2 A
MAXIMUM SWITCHING POWER	60 W dc, 62.5 VA
<i>*Maximum switched power is at 30 V/ 2 A dc. Max switched power is derated non-linearly as voltage is increased.</i>	
RATED SWITCH OPERATIONS	
Mechanical	1 x 10 ⁸ (no load)
Electrical	Min. 1 x 10 ⁵ @ (resistive load, 250VAC/0.25A), (resistive load, 30VDC/2A)
SWITCHING TIME	< 8 ms
PATH RESISTANCE	< 500 mΩ
INSULATION RESISTANCE	> 1 x 10 ⁹ Ω
MAXIMUM THERMAL OFFSET PER CHANNEL (HI-LO)	< 10 μV
CAPACITANCE	
Open channel	< 36 pF
Channel-mainframe	< 311 pF
High-low	< 364 pF
BANDWIDTH (-3 dB)	24 MHz (best), 21 MHz (worst)
CROSSTALK (TYPICAL)	
100 KHz	< -66 dB
1 MHz	< -51 dB
ISOLATION (TYPICAL)	
100 kHz	< -78 dB
1 MHz	< -53 dB
INSERTION LOSS	
100 kHz	< 0.18 dB
1 MHz	< 0.21 dB
10 MHz	< 0.24 dB

FOR MATING CONNECTOR, CRIMP PINS, AND OTHER ACCESSORIES, PLEASE REFER TO *APPENDIX B*

SMX-3276, MATRIX MODULE

(1) 1 x 76 2-WIRE FIXED MULTIPLEXER

The SMX-3279DS, PXIe high-density multiplexer modules designed for scanning of multiple points to a common bus, in 2-wire configuration mode. The SMX-3279DS consists of one (1 x 76) multiplexer.

In contrast to the SMX-3279 the SMX-3279DS has internal residual voltage discharge relays that can be enabled to momentarily short out the measurement path when changing from one input channel to the next. This dissipates any voltage held by the wiring and instrument input capacitance. These relays protect sensitive devices, such as CMOS circuits, from residual voltages caused by previous high-voltage measurements. This feature can also be disabled in low-voltage applications where maximum throughput speed is important.

The SMX-3279DS incorporates extensive signal shielding and exposes shield pins on the front panel connector for tying to the cable shield. This preserves signal integrity throughout the signal path by maintaining the signals at the same reference level as the UUT. In addition, meticulous signal routing is done for impedance matching, signal shielding and cross talk reduction, allowing the SMX-3279DS to achieve best in class switching performance with a bandwidth of > 20 MHz. This performance allows the card to be used with high frequency signals, and signals that have fast rise times and narrow pulse widths.

NOTE SMX-3279DS where DS stands for DISCHARGE relays support

CONNECTOR PINS AND SIGNALS

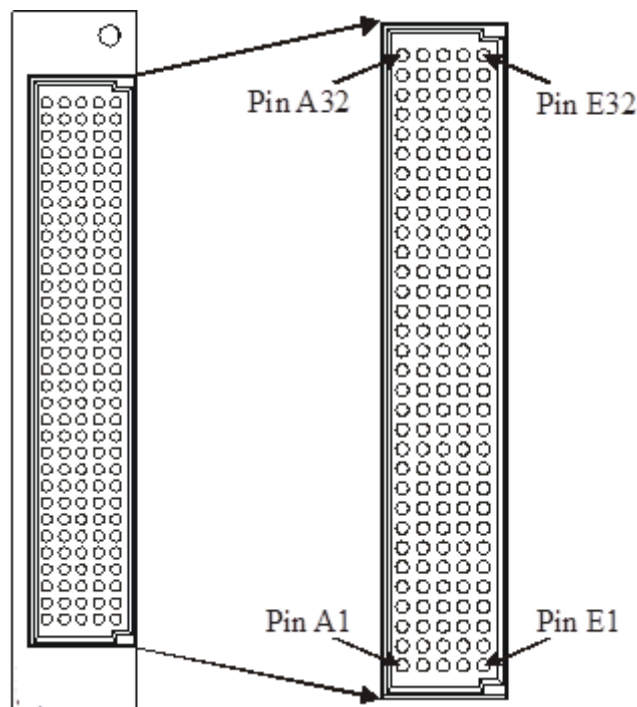

FIGURE 3-55: SMX-3279DS FRONT PANEL CONNECTOR (FRONT VIEW)

Row A		Row B		Row C		Row D		Row E	
Pin	Signal	Pin	Signal	Pin	Signal	Pin	Signal	Pin	Signal
1	USR_SHIELD	1	CH_37L	1	CH_37H	1	CH_38L	1	CH_38H
2	CH_3L	2	CH_4L	2	CH_8L	2	CH_7L	2	CH_1L
3	CH_3H	3	CH_4H	3	CH_8H	3	CH_7H	3	CH_1H
4	CH_5L	4	CH_6L	4	CH_2L	4	CH_9L	4	CH_11L
5	CH_5H	5	CH_6H	5	CH_2H	5	CH_9H	5	CH_11H
6	CH_10L	6	CH_15L	6	CH_13L	6	CH_17L	6	CH_18L
7	CH_10H	7	CH_15H	7	CH_13H	7	CH_17H	7	CH_18H
8	CH_14L	8	CH_26L	8	CH_12L	8	CH_27L	8	CH_16L
9	CH_14H	9	CH_26H	9	CH_12H	9	CH_27H	9	CH_16H
10	CH_24L	10	CH_19L	10	CH_21L	10	CH_25L	10	CH_22L
11	CH_24H	11	CH_19H	11	CH_21H	11	CH_25H	11	CH_22H
12	CH_36L	12	CH_20L	12	CH_30L	12	CH_23L	12	CH_31L
13	CH_36H	13	CH_20H	13	CH_30H	13	CH_23H	13	CH_31H
14	CH_COML	14	CH_28L	14	CH_29L	14	CH_35L	14	CH_34L
15	CH_COMH	15	CH_28H	15	CH_29H	15	CH_35H	15	CH_34H
16	CH_33L	16	CH_32L	16	CH_43L	16	CH_42L	16	UNUSED
17	CH_33H	17	CH_32H	17	CH_43H	17	CH_42H	17	UNUSED
18	CH_39L	18	CH_46L	18	CH_41L	18	CH_40L	18	CH_47L
19	CH_39H	19	CH_46H	19	CH_41H	19	CH_40H	19	CH_47H
20	CH_45L	20	CH_52L	20	CH_51L	20	CH_44L	20	USR_SHIELD
21	CH_45H	21	CH_52H	21	CH_51H	21	CH_44H	21	USR_SHIELD
22	CH_49L	22	CH_50L	22	CH_55L	22	CH_48L	22	CH_56L
23	CH_49H	23	CH_50H	23	CH_55H	23	CH_48H	23	CH_56H
24	CH_61L	24	CH_54L	24	CH_53L	24	CH_57L	24	CH_60L
25	CH_61H	25	CH_54H	25	CH_53H	25	CH_57H	25	CH_60H
26	CH_65L	26	CH_58L	26	CH_64L	26	CH_67L	26	CH_59L
27	CH_65H	27	CH_58H	27	CH_64H	27	CH_67H	27	CH_59H
28	CH_68L	28	CH_63L	28	CH_72L	28	CH_62L	28	CH_70L
29	CH_68H	29	CH_63H	29	CH_72H	29	CH_62H	29	CH_70H
30	CH_69L	30	CH_71L	30	CH_66L	30	CH_74L	30	CH_73L
31	CH_69H	31	CH_71H	31	CH_66H	31	CH_74H	31	CH_73H
32	USR_SHIELD	32	CH_75L	32	CH_75H	32	CH_76L	32	CH_76H

TABLE 3-26: SMX-3279DS CONNECTOR PINS & SIGNAL ASSIGNMENTS

LOGICAL DIAGRAM

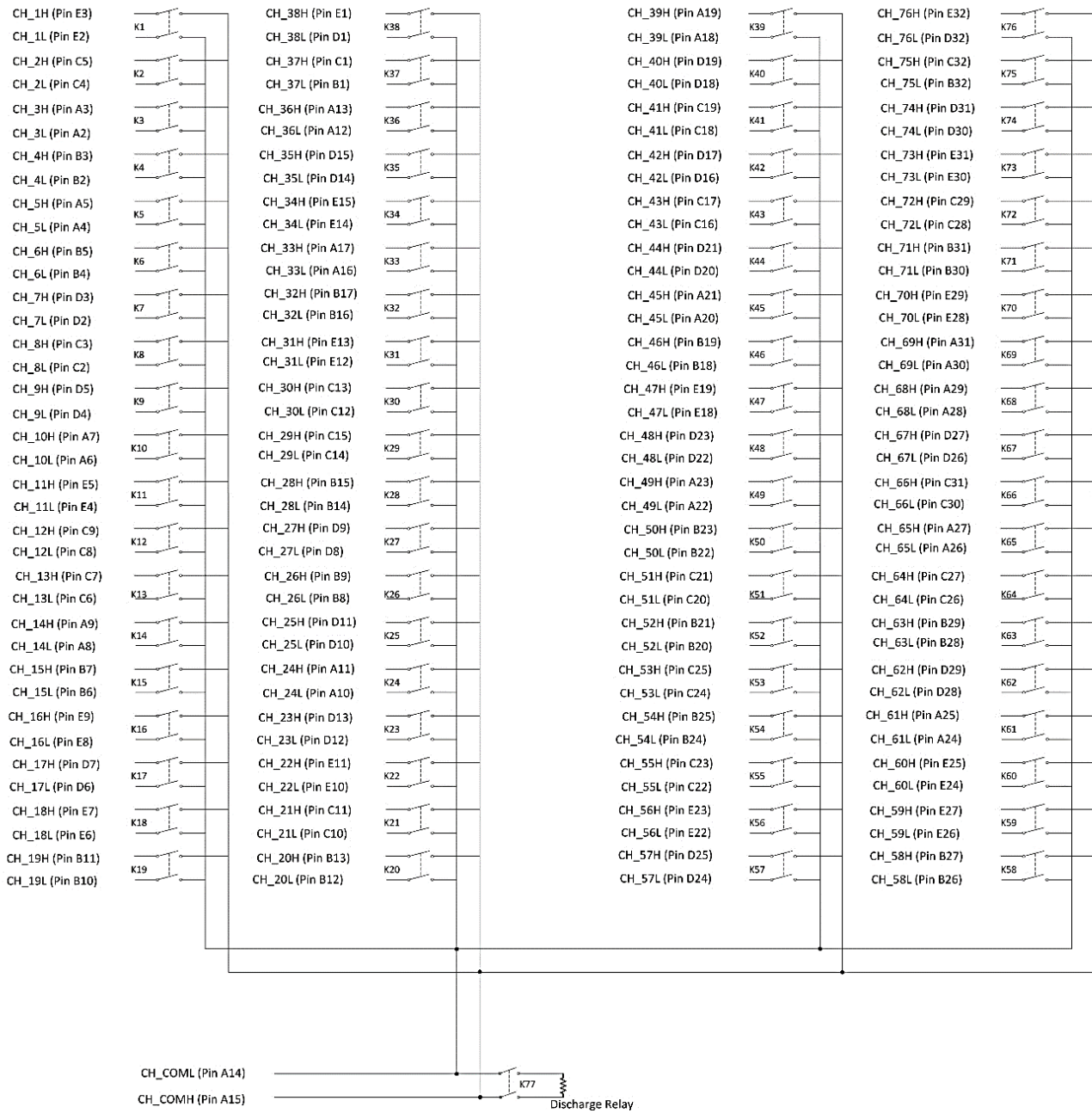

FIGURE 3-56: SMX-3279DS LOGICAL DIAGRAM

SMX-3279DS SPECIFICATIONS

GENERAL SPECIFICATIONS	
CHANNEL COUNT	(1) 1x76 2-wire Multiplexer
RELAY TYPE	Electromechanical, fail-safe
MAXIMUM SWITCHING VOLTAGE	300 V dc, 300 V ac
MAXIMUM SWITCHING CURRENT	2 A
MAXIMUM SWITCHING POWER	60 W dc, 62.5 VA
<i>*Maximum switched power is at 30 V/ 2 A dc. Max switched power is derated non-linearly as voltage is increased.</i>	
RATED SWITCH OPERATIONS	
Mechanical	1 x 10 ⁸ (no load)
Electrical	Min. 1 x 10 ⁵ @ (resistive load, 250VAC/0.25A), (resistive load, 30VDC/2A)
SWITCHING TIME	< 8 ms
PATH RESISTANCE	< 500 mΩ
INSULATION RESISTANCE	> 1 x 10 ⁹ Ω
MAXIMUM THERMAL OFFSET PER CHANNEL (HI-LO)	
	< 10 μV
CAPACITANCE	
Open channel	< 36 pF
Channel-mainframe	< 311 pF
High-low	< 364 pF
BANDWIDTH (-3 dB)	
	24 MHz (best), 21 MHz (worst)
CROSSTALK (TYPICAL)	
100 KHz	< -66 dB
1 MHz	< -51 dB
ISOLATION (TYPICAL)	
100 kHz	< -78 dB
1 MHz	< -53 dB
INSERTION LOSS	
100 kHz	< 0.18 dB
1 MHz	< 0.21 dB
10 MHz	< 0.24 dB

FOR MATING CONNECTOR, CRIMP PINS, AND OTHER ACCESSORIES, PLEASE REFER TO *APPENDIX B*

SMX-3276, MATRIX MODULE

(1) 1 x 152 1-WIRE FIXED MULTIPLEXER

The SMX-3280, PXIe high-density multiplexer modules designed for scanning of multiple points to a common bus, in 1-wire configuration mode. The SMX-3280 consists of one (1 x 152) multiplexer.

The SMX-3280 incorporates extensive signal shielding and exposes shield pins on the front panel connector for tying to the cable shield. This preserves signal integrity throughout the signal path by maintaining the signals at the same reference level as the UUT. In addition, meticulous signal routing is done for impedance matching, signal shielding and cross talk reduction, allowing the SMX-3280 to achieve best in class switching performance with a bandwidth of > 30 MHz. This performance allows the card to be used with high frequency signals, and signals that have fast rise times and narrow pulse widths.

CONNECTOR PINS AND SIGNALS

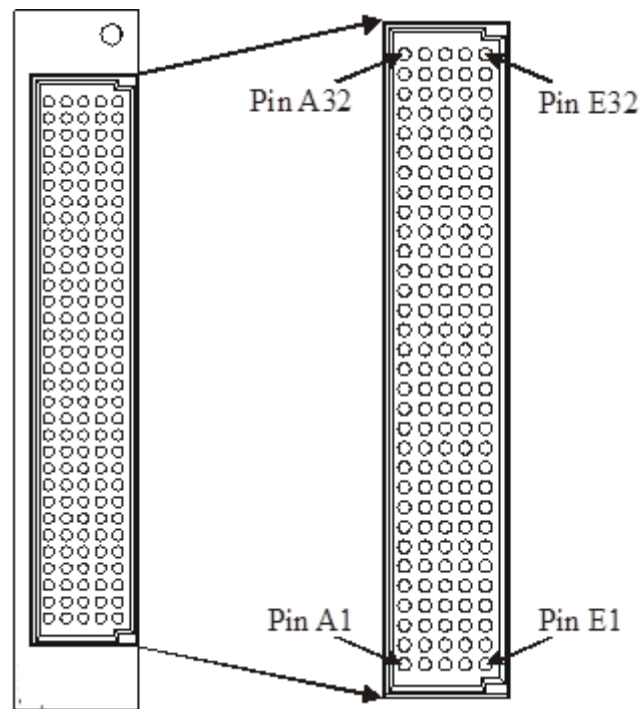

FIGURE 3-57: SMX-3280 FRONT PANEL CONNECTOR (FRONT VIEW)

Row A		Row B		Row C		Row D		Row E	
Pin	Signal	Pin	Signal	Pin	Signal	Pin	Signal	Pin	Signal
1	USR_SHIELD	1	CH_37L	1	CH_37H	1	CH_38L	1	CH_38H
2	CH_3L	2	CH_4L	2	CH_8L	2	CH_7L	2	CH_1L
3	CH_3H	3	CH_4H	3	CH_8H	3	CH_7H	3	CH_1H
4	CH_5L	4	CH_6L	4	CH_2L	4	CH_9L	4	CH_11L
5	CH_5H	5	CH_6H	5	CH_2H	5	CH_9H	5	CH_11H
6	CH_10L	6	CH_15L	6	CH_13L	6	CH_17L	6	CH_18L
7	CH_10H	7	CH_15H	7	CH_13H	7	CH_17H	7	CH_18H
8	CH_14L	8	CH_26L	8	CH_12L	8	CH_27L	8	CH_16L
9	CH_14H	9	CH_26H	9	CH_12H	9	CH_27H	9	CH_16H
10	CH_24L	10	CH_19L	10	CH_21L	10	CH_25L	10	CH_22L
11	CH_24H	11	CH_19H	11	CH_21H	11	CH_25H	11	CH_22H
12	CH_36L	12	CH_20L	12	CH_30L	12	CH_23L	12	CH_31L
13	CH_36H	13	CH_20H	13	CH_30H	13	CH_23H	13	CH_31H
14	UNUSED	14	CH_28L	14	CH_29L	14	CH_35L	14	CH_34L
15	CH_COM_1W	15	CH_28H	15	CH_29H	15	CH_35H	15	CH_34H
16	CH_33H	16	CH_32L	16	CH_43L	16	CH_42L	16	UNUSED
17	CH_33L	17	CH_32H	17	CH_43H	17	CH_42H	17	UNUSED
18	CH_39L	18	CH_46L	18	CH_41L	18	CH_40L	18	CH_47L
19	CH_39H	19	CH_46H	19	CH_41H	19	CH_40H	19	CH_47H
20	CH_45L	20	CH_52L	20	CH_51L	20	CH_44L	20	USR_SHIELD
21	CH_45H	21	CH_52H	21	CH_51H	21	CH_44H	21	USR_SHIELD
22	CH_49L	22	CH_50L	22	CH_55L	22	CH_48L	22	CH_56L
23	CH_49H	23	CH_50H	23	CH_55H	23	CH_48H	23	CH_56H
24	CH_61L	24	CH_54L	24	CH_53L	24	CH_57L	24	CH_60L
25	CH_61H	25	CH_54H	25	CH_53H	25	CH_57H	25	CH_60H
26	CH_65L	26	CH_58L	26	CH_64L	26	CH_67L	26	CH_59L
27	CH_65H	27	CH_58H	27	CH_64H	27	CH_67H	27	CH_59H
28	CH_68L	28	CH_63L	28	CH_72L	28	CH_62L	28	CH_70L
29	CH_68H	29	CH_63H	29	CH_72H	29	CH_62H	29	CH_70H
30	CH_69L	30	CH_71L	30	CH_66L	30	CH_74L	30	CH_73L
31	CH_69H	31	CH_71H	31	CH_66H	31	CH_74H	31	CH_73H
32	USR_SHIELD	32	CH_75L	32	CH_75H	32	CH_76L	32	CH_76H

TABLE 3-27: SMX-3280 CONNECTOR PINS & SIGNAL ASSIGNMENTS

LOGICAL DIAGRAM

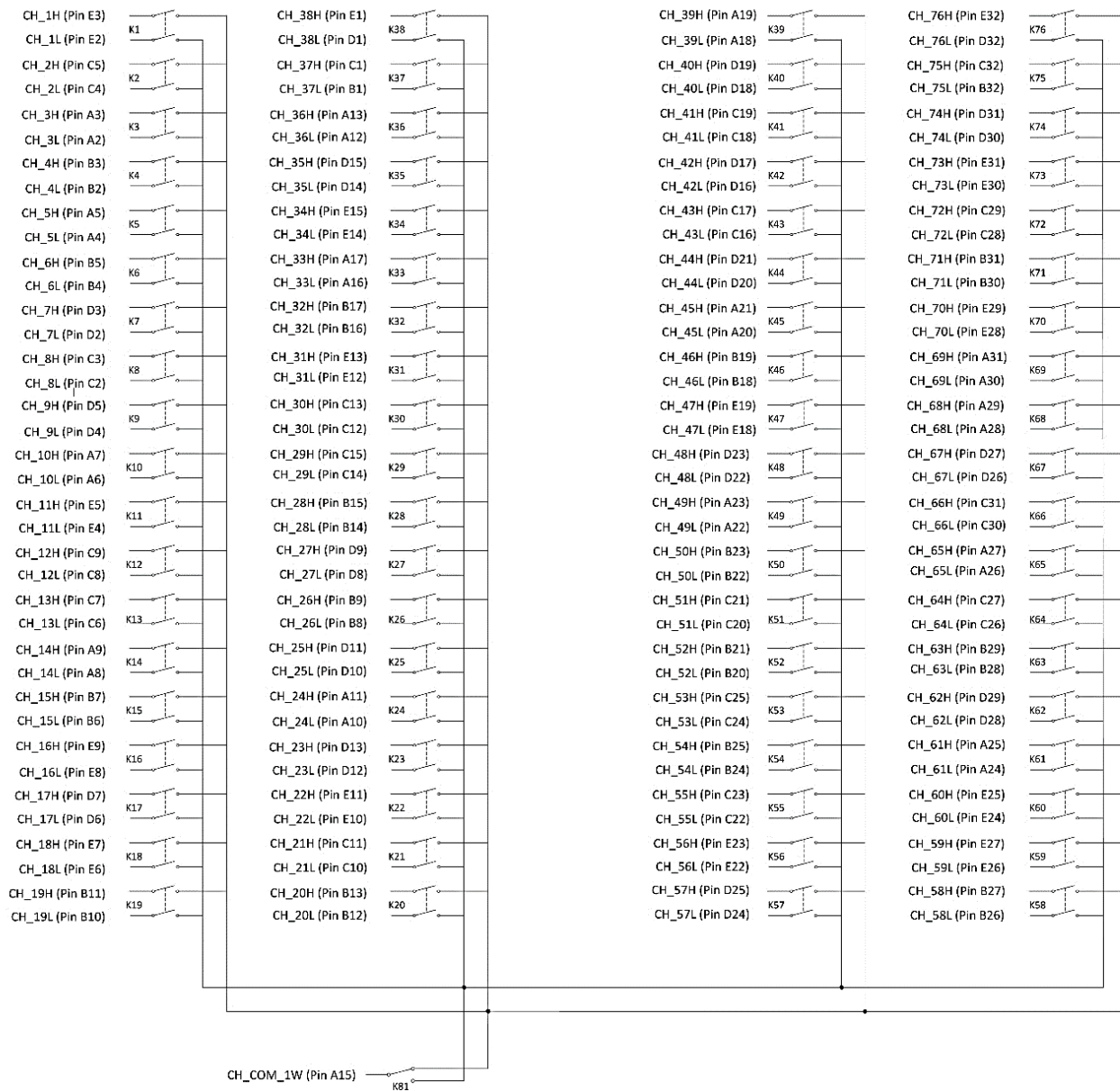

FIGURE 3-58: SMX-3280 LOGICAL DIAGRAM

SMX-3280 SPECIFICATIONS

GENERAL SPECIFICATIONS	
CHANNEL COUNT	(1) 1x152 1-wire Multiplexer
RELAY TYPE	Electromechanical, fail-safe
MAXIMUM SWITCHING VOLTAGE	300 V dc, 300 V ac
MAXIMUM SWITCHING CURRENT	2 A
MAXIMUM SWITCHING POWER	60 W dc, 62.5 VA
<i>*Maximum switched power is at 30 V/ 2 A dc. Max switched power is derated non-linearly as voltage is increased.</i>	
RATED SWITCH OPERATIONS	
Mechanical	1 x 10 ⁸ (no load)
Electrical	Min. 1 x 10 ⁵ @ (resistive load, 250VAC/0.25A), (resistive load, 30VDC/2A)
SWITCHING TIME	< 8 ms
PATH RESISTANCE	< 500 mΩ
INSULATION RESISTANCE	> 1 x 10 ⁹ Ω
MAXIMUM THERMAL OFFSET PER CHANNEL (HI-LO)	
	< 10 μV
CAPACITANCE	
Open channel	< 37 pF
Channel-mainframe	< 200 pF
High-low	< 196 pF
BANDWIDTH (-3 dB)	33 MHz (best), 33 MHz (worst)
CROSSTALK (TYPICAL)	
100 KHz	< -70 dB
1 MHz	< -51 dB
ISOLATION (TYPICAL)	
100 kHz	< -70 dB
1 MHz	< -40 dB
INSERTION LOSS	
100 kHz	< 0.01 dB
1 MHz	< 0.35 dB
10 MHz	< 1.54 dB

FOR MATING CONNECTOR, CRIMP PINS, AND OTHER ACCESSORIES, PLEASE REFER TO *APPENDIX B*

SMX-3276, MATRIX MODULE

(1) 1 x 152 1-WIRE FIXED MULTIPLEXER

The SMX-3280DS, PXIe high-density multiplexer modules designed for scanning of multiple points to a common bus, in 1-wire configuration mode. The SMX-3280DS consists of one (1 x 152) multiplexer.

In contrast to the SMX-3280 the SMX-3280DS has internal residual voltage discharge relays that can be enabled to momentarily short out the measurement path when changing from one input channel to the next. This dissipates any voltage held by the wiring and instrument input capacitance. These relays protect sensitive devices, such as CMOS circuits, from residual voltages caused by previous high-voltage measurements. This feature can also be disabled in low-voltage applications where maximum throughput speed is important.

The SMX-3280DS incorporates extensive signal shielding and exposes shield pins on the front panel connector for tying to the cable shield. This preserves signal integrity throughout the signal path by maintaining the signals at the same reference level as the UUT. In addition, meticulous signal routing is done for impedance matching, signal shielding and cross talk reduction, allowing the SMX-3280DS to achieve best in class switching performance with a bandwidth of > 30 MHz. This performance allows the card to be used with high frequency signals, and signals that have fast rise times and narrow pulse widths.

NOTE SMX-3280DS where DS stands for DISCHARGE relays support

CONNECTOR PINS AND SIGNALS

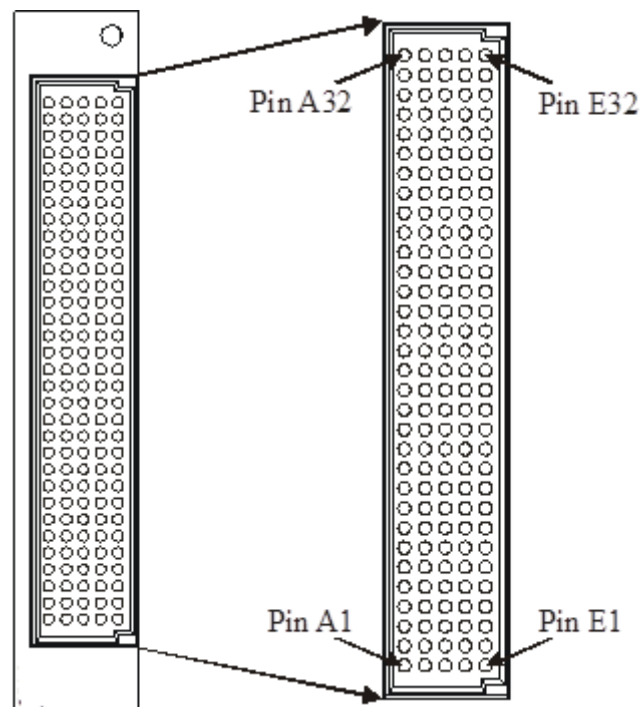

FIGURE 3-59: SMX-3280DS FRONT PANEL CONNECTOR (FRONT VIEW)

Row A		Row B		Row C		Row D		Row E	
Pin	Signal	Pin	Signal	Pin	Signal	Pin	Signal	Pin	Signal
1	USR_SHIELD	1	CH_37L	1	CH_37H	1	CH_38L	1	CH_38H
2	CH_3L	2	CH_4L	2	CH_8L	2	CH_7L	2	CH_1L
3	CH_3H	3	CH_4H	3	CH_8H	3	CH_7H	3	CH_1H
4	CH_5L	4	CH_6L	4	CH_2L	4	CH_9L	4	CH_11L
5	CH_5H	5	CH_6H	5	CH_2H	5	CH_9H	5	CH_11H
6	CH_10L	6	CH_15L	6	CH_13L	6	CH_17L	6	CH_18L
7	CH_10H	7	CH_15H	7	CH_13H	7	CH_17H	7	CH_18H
8	CH_14L	8	CH_26L	8	CH_12L	8	CH_27L	8	CH_16L
9	CH_14H	9	CH_26H	9	CH_12H	9	CH_27H	9	CH_16H
10	CH_24L	10	CH_19L	10	CH_21L	10	CH_25L	10	CH_22L
11	CH_24H	11	CH_19H	11	CH_21H	11	CH_25H	11	CH_22H
12	CH_36L	12	CH_20L	12	CH_30L	12	CH_23L	12	CH_31L
13	CH_36H	13	CH_20H	13	CH_30H	13	CH_23H	13	CH_31H
14	UNUSED	14	CH_28L	14	CH_29L	14	CH_35L	14	CH_34L
15	CH_COM_1W	15	CH_28H	15	CH_29H	15	CH_35H	15	CH_34H
16	CH_33H	16	CH_32L	16	CH_43L	16	CH_42L	16	UNUSED
17	CH_33H	17	CH_32H	17	CH_43H	17	CH_42H	17	UNUSED
18	CH_39L	18	CH_46L	18	CH_41L	18	CH_40L	18	CH_47L
19	CH_39H	19	CH_46H	19	CH_41H	19	CH_40H	19	CH_47H
20	CH_45L	20	CH_52L	20	CH_51L	20	CH_44L	20	USR_SHIELD
21	CH_45H	21	CH_52H	21	CH_51H	21	CH_44H	21	USR_SHIELD
22	CH_49L	22	CH_50L	22	CH_55L	22	CH_48L	22	CH_56L
23	CH_49H	23	CH_50H	23	CH_55H	23	CH_48H	23	CH_56H
24	CH_61L	24	CH_54L	24	CH_53L	24	CH_57L	24	CH_60L
25	CH_61H	25	CH_54H	25	CH_53H	25	CH_57H	25	CH_60H
26	CH_65L	26	CH_58L	26	CH_64L	26	CH_67L	26	CH_59L
27	CH_65H	27	CH_58H	27	CH_64H	27	CH_67H	27	CH_59H
28	CH_68L	28	CH_63L	28	CH_72L	28	CH_62L	28	CH_70L
29	CH_68H	29	CH_63H	29	CH_72H	29	CH_62H	29	CH_70H
30	CH_69L	30	CH_71L	30	CH_66L	30	CH_74L	30	CH_73L
31	CH_69H	31	CH_71H	31	CH_66H	31	CH_74H	31	CH_73H
32	USR_SHIELD	32	CH_75L	32	CH_75H	32	CH_76L	32	CH_76H

TABLE 3-28: SMX-3280DS CONNECTOR PINS & SIGNAL ASSIGNMENTS

LOGICAL DIAGRAM



FIGURE 3-60: SMX-3280DS LOGICAL DIAGRAM

SMX-3280DS SPECIFICATIONS

GENERAL SPECIFICATIONS	
CHANNEL COUNT	(1) 1x152 1-wire Multiplexer
RELAY TYPE	Electromechanical, fail-safe
MAXIMUM SWITCHING VOLTAGE	300 V dc, 300 V ac
MAXIMUM SWITCHING CURRENT	2 A
MAXIMUM SWITCHING POWER	60 W dc, 62.5 VA
<i>*Maximum switched power is at 30 V/ 2 A dc. Max switched power is derated non-linearly as voltage is increased.</i>	
RATED SWITCH OPERATIONS	
Mechanical	1 x 10 ⁸ (no load)
Electrical	Min. 1 x 10 ⁵ @ (resistive load, 250VAC/0.25A), (resistive load, 30VDC/2A)
SWITCHING TIME	< 8 ms
PATH RESISTANCE	< 500 mΩ
INSULATION RESISTANCE	> 1 x 10 ⁹ Ω
MAXIMUM THERMAL OFFSET PER CHANNEL (HI-LO)	
	< 10 μV
CAPACITANCE	
Open channel	< 37 pF
Channel-mainframe	< 200 pF
High-low	< 196 pF
BANDWIDTH (-3 dB)	
	33 MHz (best), 33 MHz (worst)
CROSSTALK (TYPICAL)	
100 KHz	< -70 dB
1 MHz	< -51 dB
ISOLATION (TYPICAL)	
100 kHz	< -70 dB
1 MHz	< -40 dB
INSERTION LOSS	
100 kHz	< 0.01 dB
1 MHz	< 0.35 dB
10 MHz	< 1.54 dB

FOR MATING CONNECTOR, CRIMP PINS, AND OTHER ACCESSORIES, PLEASE REFER TO *APPENDIX B*

SMX-4410, MATRIX MODULE

(4) 4x10 2-WIRE FULLY CONFIGURABLE MATRIX

The SMX-4410 is a 3U, high-density PXIe matrix module that allows the user to connect any input row to any output column, with a DPST relay at every row/column cross point. This architecture provides the framework for flexible switch system designs where multiple test instruments need to be connected to common test points.

The SMX-4410 contains four (4x10) 2-wire matrix blocks that can be bussed together under software control to create 2 (8x10), or 1 (8x20), or 2 (4x20), or 1 (4x40) 2-wire matrix, providing the user flexibility and simplifying field wiring. The card is capable of switching up to 300V, 2A enabling it to be used over a wide range of applications. It also includes an embedded Self-Test mechanism that can be used to determine relay health.

The SMX-4410 incorporates extensive signal shielding and exposes shield pins on the front panel connector for tying to the cable shield. This preserves signal integrity throughout the signal path by maintaining the signals at the same reference level as the UUT. In addition, meticulous signal routing is done for signal shielding and cross talk reduction, allowing the SMX-4410 to achieve best in class switching performance. This performance allows the card to be used with high frequency signals, and signals that have fast rise times and narrow pulse widths

NOTE All SMX-441x Modules support SELF TEST

CONNECTOR PINS AND SIGNALS

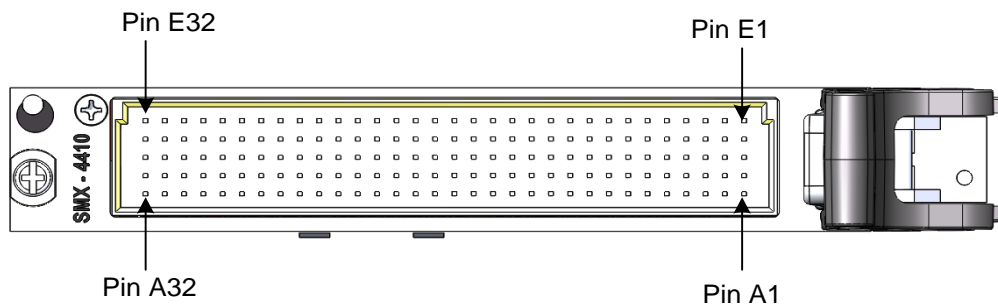

FIGURE 3-61: SMX-4410 FRONT PANEL (FRONT VIEW)

Row A		Row B		Row C		Row D		Row E	
Pin	Signal	Pin	Signal	Pin	Signal	Pin	Signal	Pin	Signal
1	USR_SHIELD	1	USR_SHIELD	1	USR_SHIELD	1	USR_SHIELD	1	USR_SHIELD
2	CH3_C6L	2	CH4_R3H	2	CH4_R3L	2	CH3_CH4_R3H	2	CH3_CH4_R3L
3	CH3_C6H	3	CH3_R3H	3	CH3_R3L	3	CH4_R2H	3	CH4_R2L
4	CH3_C1L	4	CH3_C7H	4	CH3_C7L	4	CH3_R2H	4	CH3_R2L
5	CH3_C1H	5	CH3_C4H	5	CH3_C4L	5	CH3_CH4_R2H	5	CH3_CH4_R2L
6	CH4_C4L	6	CH4_C8H	6	CH4_C8L	6	CH4_C7H	6	CH4_C7L
7	CH4_C4H	7	CH3_C5H	7	CH3_C5L	7	CH3_R1H	7	CH3_R1L
8	CH3_C8L	8	CH4_R1H	8	CH4_R1L	8	CH3_CH4_R1H	8	CH3_CH4_R1L
9	CH3_C8H	9	CH4_R4H	9	CH4_R4L	9	CH3_CH4_R4H	9	CH3_CH4_R4L
10	CH3_C3L	10	CH2_C5H	10	CH2_C5L	10	CH3_R4H	10	CH3_R4L
11	CH3_C3H	11	CH2_C1H	11	CH2_C1L	11	CH4_C10H	11	CH4_C10L
12	CH1_C6L	12	CH3_C2H	12	CH3_C2L	12	CH3_C10H	12	CH3_C10L
13	CH1_C6H	13	CH3_C9H	13	CH3_C9L	13	CH4_C6H	13	CH4_C6L
14	CH4_C3L	14	CH1_C1H	14	CH1_C1L	14	CH4_C5H	14	CH4_C5L
15	CH4_C3H	15	CH2_C4H	15	CH2_C4L	15	CH2_C3H	15	CH2_C3L
16	CH1_C7L	16	CH1_C2H	16	CH1_C2L	16	CH4_C2H	16	CH4_C2L
17	CH1_C7H	17	CH2_R4H	17	CH2_R4L	17	CH4_C9H	17	CH4_C9L
18	CH1_R4L	18	CH2_C10H	18	CH2_C10L	18	CH1_CH2_R3H	18	CH1_CH2_R3L
19	CH1_R4H	19	CH1_C8H	19	CH1_C8L	19	CH1_C3H	19	CH1_C3L
20	CH1_R3L	20	CH2_C9H	20	CH2_C9L	20	CH1_CH2_R4H	20	CH1_CH2_R4L
21	CH1_R3H	21	UNUSED	21	UNUSED	21	CH1_CH2_R2H	21	CH1_CH2_R2L
22	CH1_C9L	22	CH2_C2H	22	CH2_C2L	22	CH2_R3H	22	CH2_R3L
23	CH1_C9H	23	CH1_C4H	23	CH1_C4L	23	CH1_CH2_R1H	23	CH1_CH2_R1L
24	UNUSED	24	CH2_R2H	24	CH2_R2L	24	CH2_C7H	24	CH2_C7L
25	UNUSED	25	UNUSED	25	UNUSED	25	USR_SHIELD	25	USR_SHIELD
26	UNUSED	26	CH2_C8H	26	CH2_C8L	26	CH4_C1H	26	CH4_C1L
27	UNUSED	27	UNUSED	27	UNUSED	27	CH1_R2H	27	CH1_R2L
28	UNUSED	28	CH1_C10H	28	CH1_C10L	28	CH1_R1H	28	CH1_R1L
29	UNUSED	29	CH2_R1H	29	CH2_R1L	29	CH2_C6H	29	CH2_C6L
30	UNUSED	30	UNUSED	30	UNUSED	30	CH1_C5H	30	CH1_C5L
31	UNUSED	31	UNUSED	31	UNUSED	31	UNUSED	31	UNUSED
32	USR_SHIELD	32	USR_SHIELD	32	USR_SHIELD	32	USR_SHIELD	32	USR_SHIELD

TABLE 3-29: SMX-4410 CONNECTOR PINS & SIGNAL ASSIGNMENTS

Logical Diagram

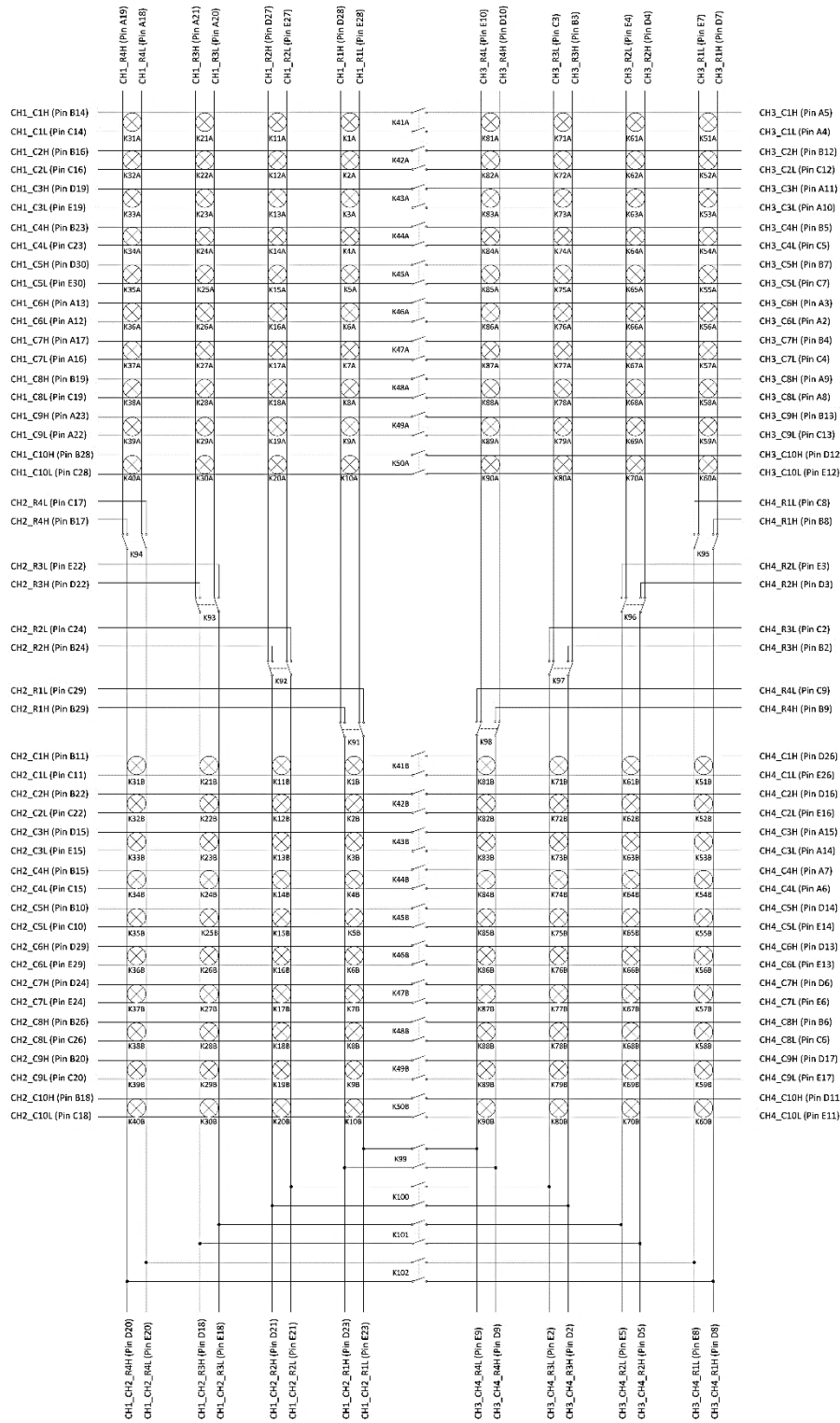

FIGURE 3-62: SMX-4410 LOGICAL DIAGRAM

SELF-TEST

The SFP (SMX-4410 Web Page) also provides SELF TEST feature which can be used to check the health status of the relays in specific and the card in general.

Open the SFP Main screen by entering the IP address

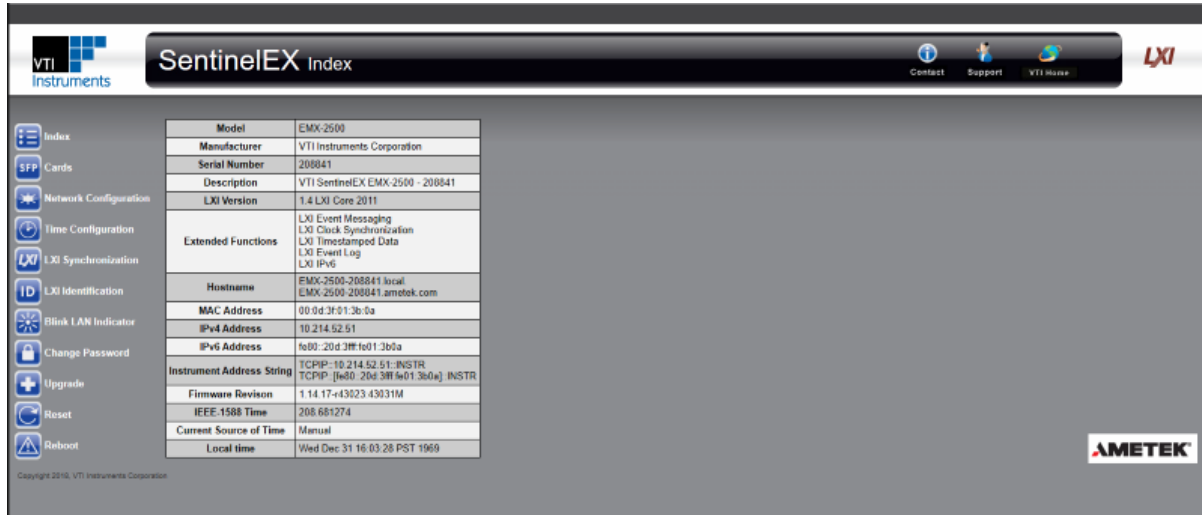

FIGURE 3-63: SFP MAIN SCREEN

Select SMX-4410 card from the Device/Cards list

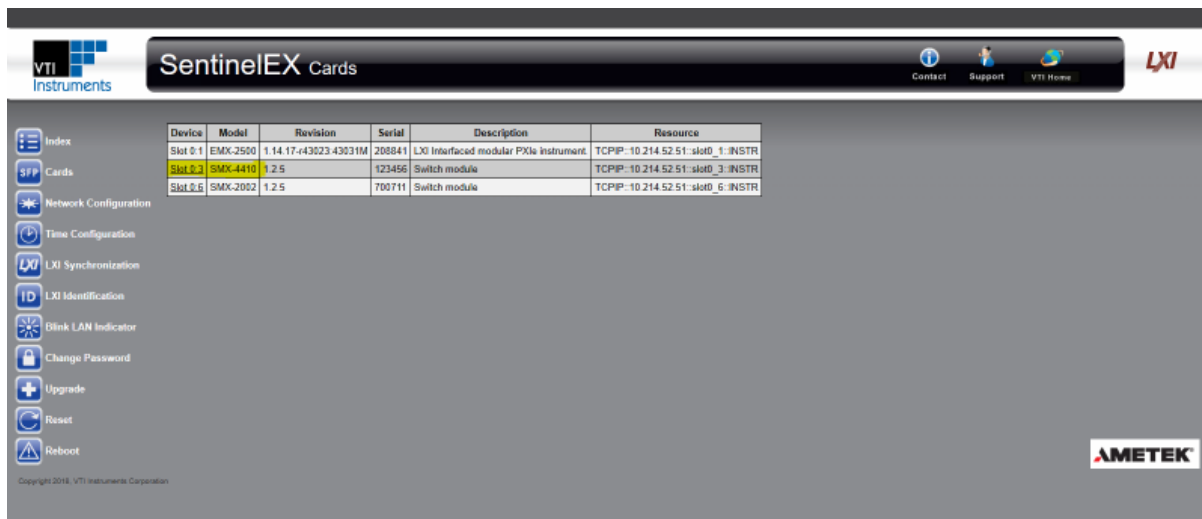

FIGURE 3-64: SFP-DEVICE/CARD SELECTION

Click on “SelfTest” button

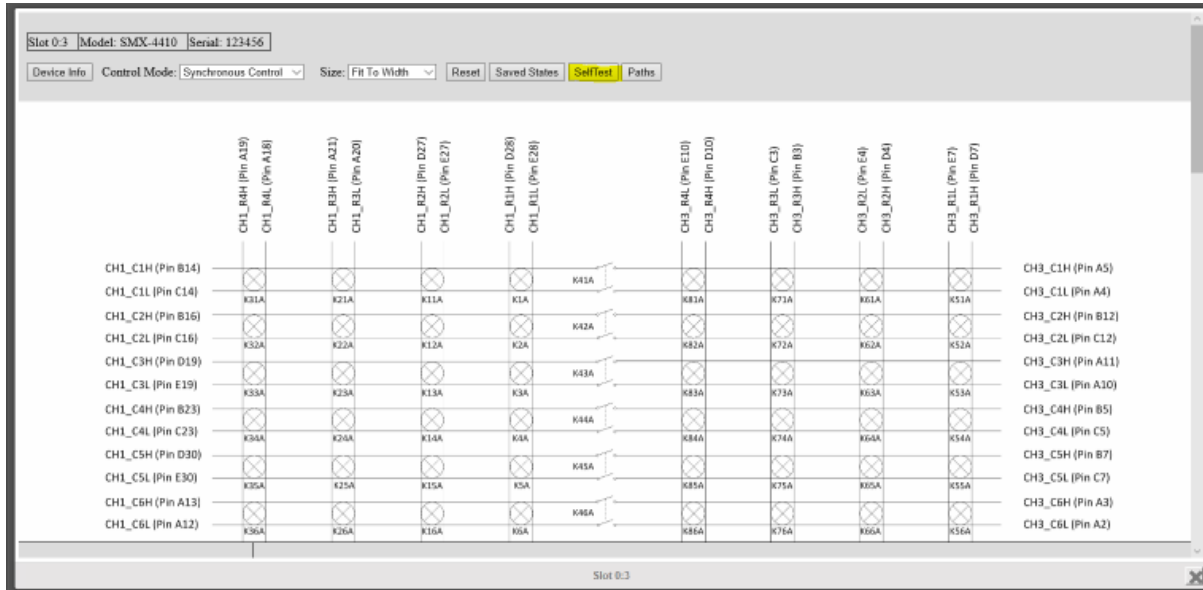

FIGURE 3-65: SMX-4410SFPSCREEN- SELFTEST

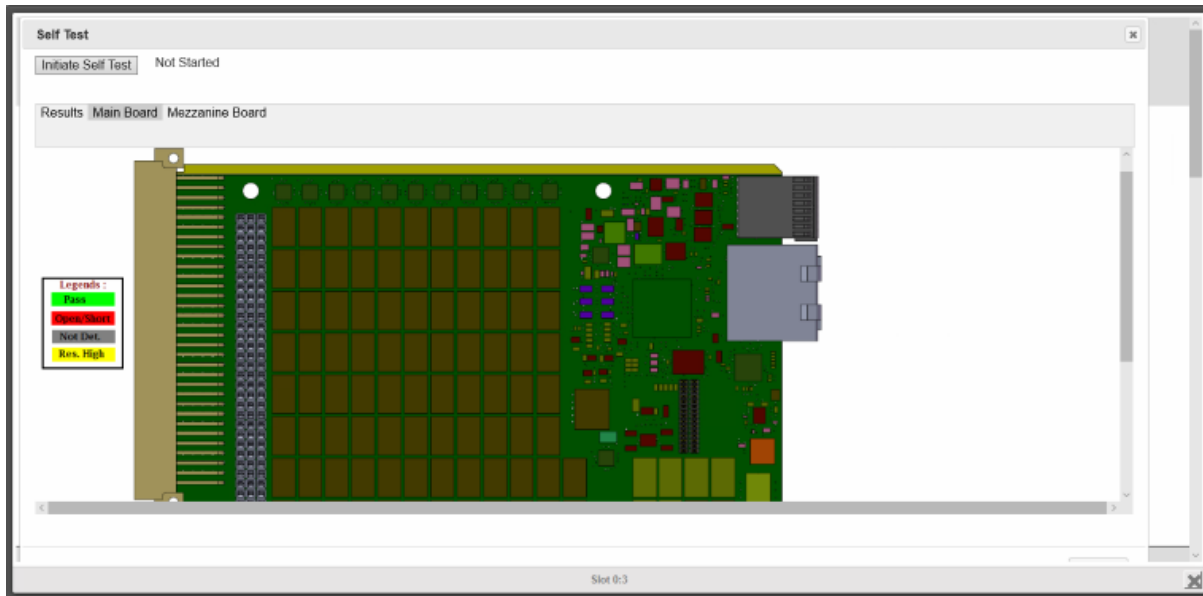

FIGURE 3-66: SMX-4410SELFTEST-MAIN BOARD RELAY LOCATION PAGE

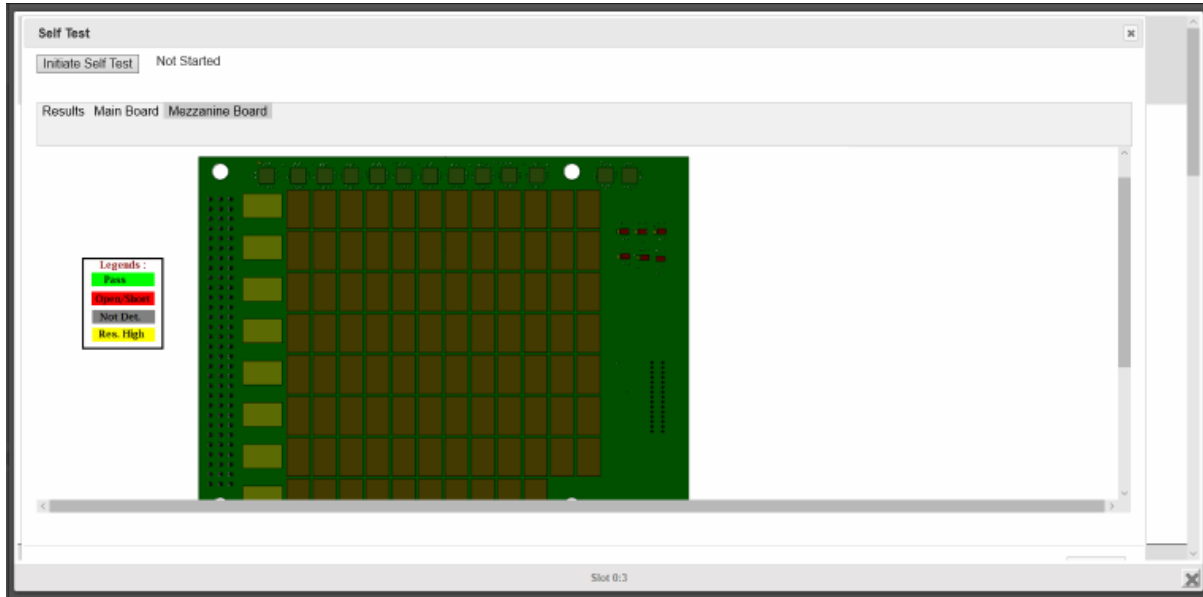

FIGURE 3-67: SMX-4410SELFTTEST-MEZZANINE BOARD RELAY LOCATION PAGE

Click on “Initiate Self Test” button to initiate the self test, this will pop-up “Please disconnect the frontpanel cable before proceeding” message. Please disconnect if any front panel connector cable is connected then click “OK”.

Threshold Limit (Ohms) by default will be 2 Ohms.

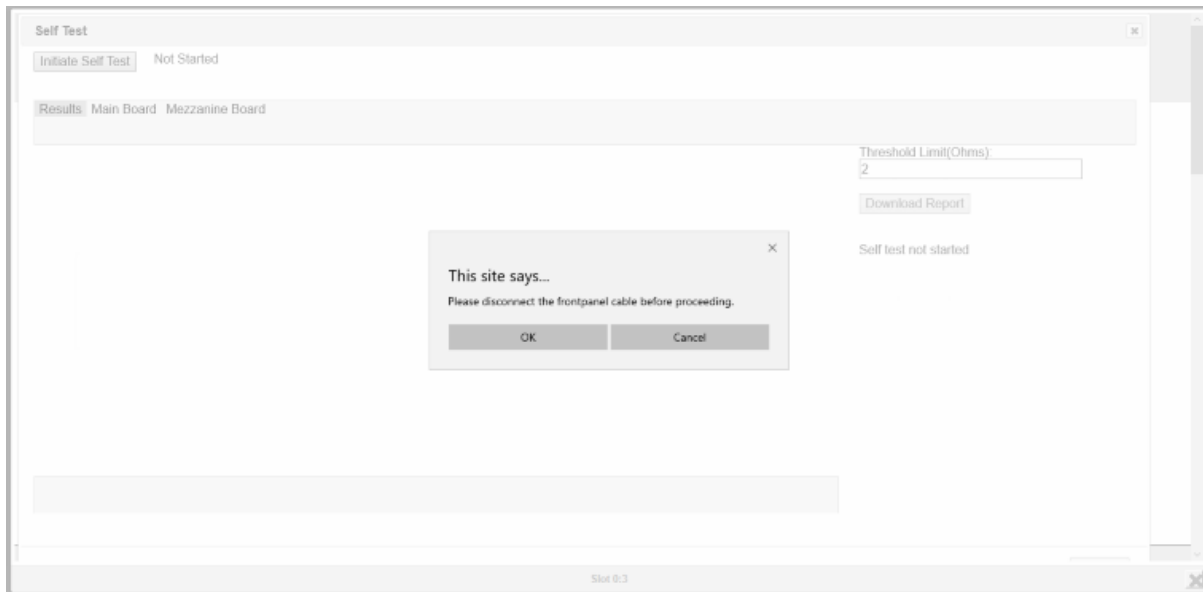

FIGURE 3-68: SMX-4410SELFTTEST-INITIATE SELF TEST

Self test execution starts and status displays “Running”

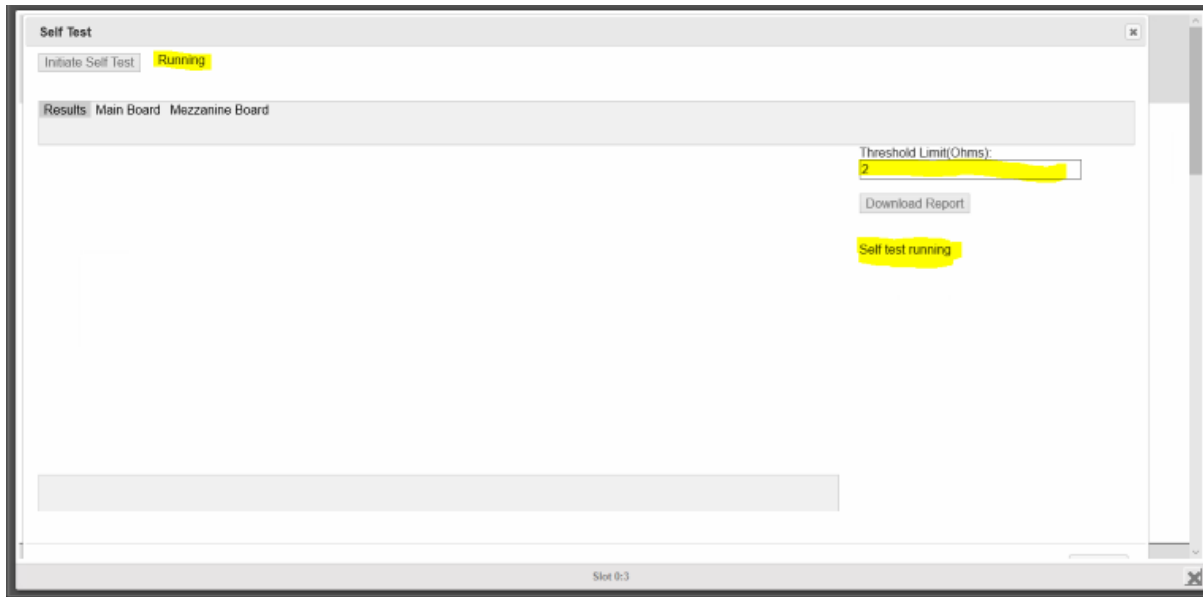

FIGURE 3-69: SMX-4410SELFTEST-RUNNING

Once the self test execution completes, status of the execution will be displayed. If the self test is fully passed then the status will be “Success” else “Failure” will be displayed

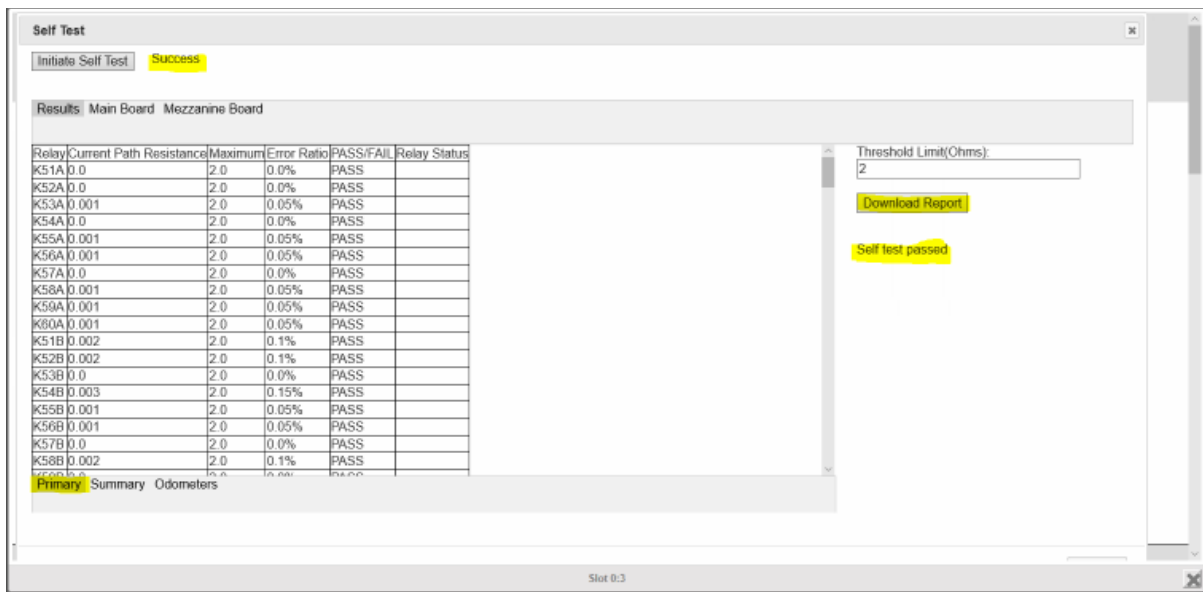

FIGURE 3-70: SMX-4410SELFTEST-STATUS SUCCESS

Self test summary details will be available in Summary tab.

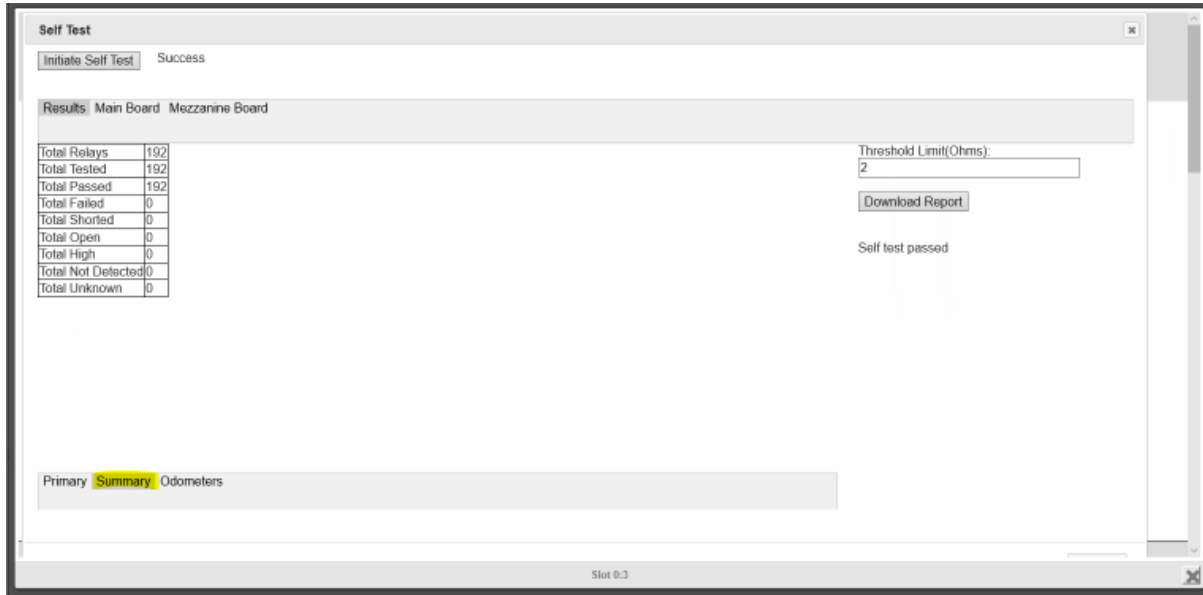

FIGURE 3-71: SMX-4410SELFTEST-SUMMARY

Relays Odometer details will be available in Odometers tab.

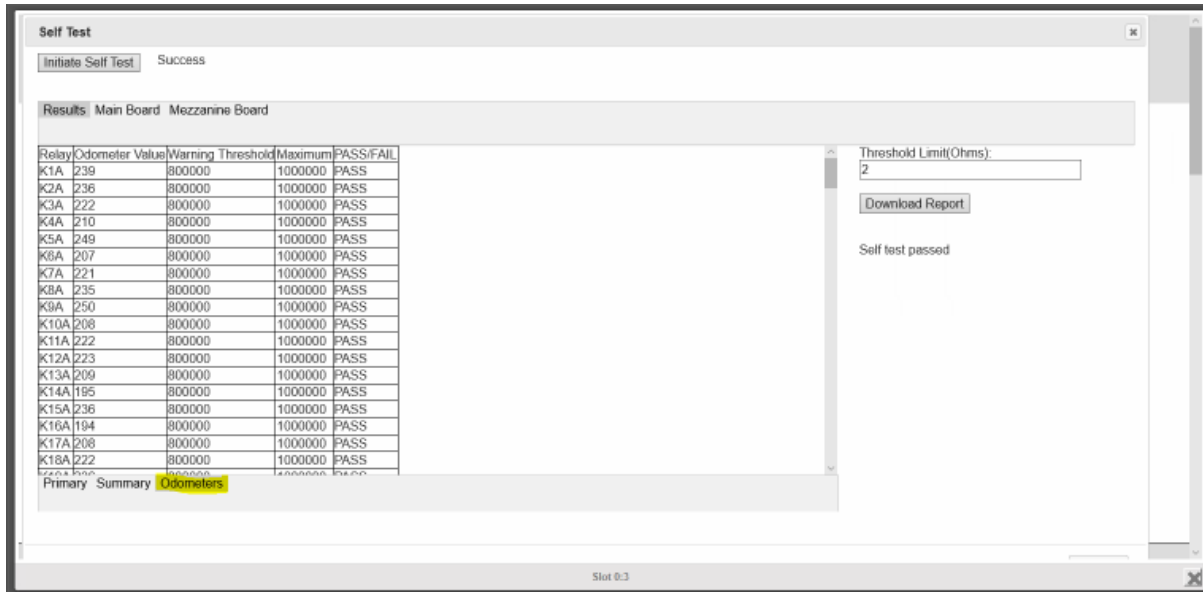

FIGURE 3-72: SMX-4410SELFTEST-ODOMETERS

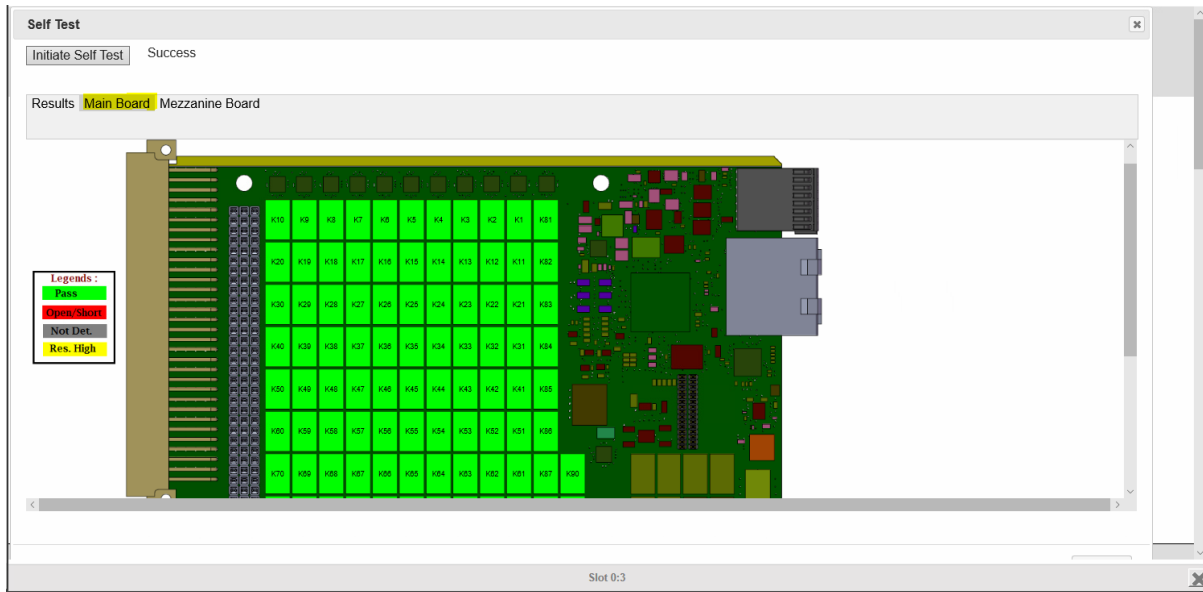

FIGURE 3-73: SMX-4410 SELF-TEST - RELAY LOCATION (MAIN BOARD) SCREEN, POST SELF-TEST INDICATING THE STATUS

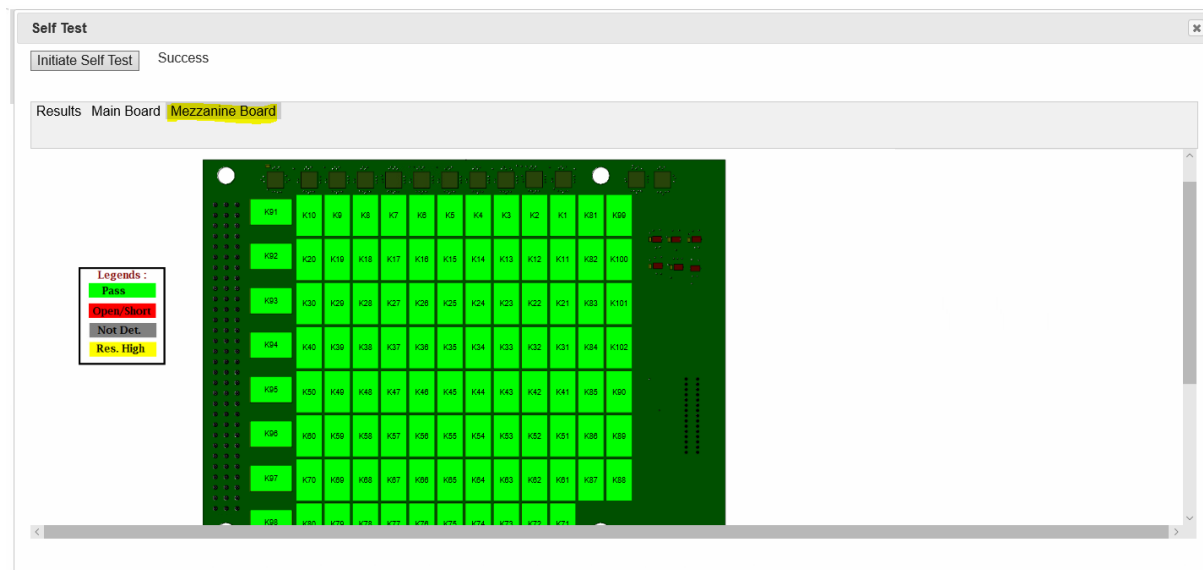

FIGURE 3-74: SMX-4410 SELF-TEST - RELAY LOCATION (MEZZANINE BOARD) SCREEN, POST SELF-TEST INDICATING THE STATUS

SMX-4410 SPECIFICATIONS

GENERAL SPECIFICATIONS	
CHANNEL COUNT	(4) 4x10, 2-wire Matrices, (2) (8x10) 2-wire Matrices, (1) (8x20) 2-wire Matrix, (2) (4x20) 2-wire Matrices, (1) (4x40) 2-wire Matrix, Fully configurable
RELAY TYPE	Electromechanical, fail-safe
MAXIMUM SWITCHING VOLTAGE	300 V dc, 300 V ac
MAXIMUM SWITCHING CURRENT	2 A
MAXIMUM SWITCHING POWER	60 W dc, 62.5 VA
<i>*Maximum switched power is at 30 V/ 2 A dc. Max switched power is derated non-linearly as voltage is increased.</i>	
RATED SWITCH OPERATIONS	
Mechanical	1 x 10 ⁸ (no load)
Electrical	Min. 1 x 10 ⁵ @ (resistive load, 250 VAC/0.25A), (resistive load, 30 VDC/2A)
SWITCHING TIME	< 8 ms
PATH RESISTANCE	< 500 mΩ
INSULATION RESISTANCE	> 1 x 10 ⁹ Ω
MAXIMUM THERMAL OFFSET PER CHANNEL (HI-LO)	< 10 μV
CAPACITANCE	
Open channel	< 39 pF
Channel-mainframe	< 269 pF
High-low	< 163 pF
BANDWIDTH (-3 dB)	82 MHz (typical), 112 MHz (best), 74 MHz (worst)
CROSSTALK (TYPICAL)	
100 kHz	< -54 dB
1 MHz	< -48 dB
ISOLATION (TYPICAL)	
100 kHz	< -79 dB
1 MHz	< -46 dB
INSERTION LOSS (TYPICAL)	
100 kHz	< 0.16 dB
1 MHz	< 0.23 dB
10MHz	< 0.52 dB

FOR MATING CONNECTOR, CRIMP PINS, AND OTHER ACCESSORIES, PLEASE REFER TO *APPENDIX B*

SMX-4410, MATRIX MODULE

(4) 4X10 2-WIRE FIXED MATRIX

The SMX-4411 is a high-density PXIe matrix module that allows the user to connect any input row to any output column, with a DPST relay at every row/column crosspoint. This architecture provides the framework for flexible switch system designs where multiple test instruments need to be connected to common test points.

The SMX-4411 contains four (4X10) 2-wire matrix providing the user flexibility and simplifying field wiring. The card is capable of switching up to 300V, 2A enabling it to be used over a wide range of applications. It also includes an embedded Self-Test mechanism that can be used to determine relay health.

The SMX-4411 incorporates extensive signal shielding and exposes shield pins on the front panel connector for tying to the cable shield. This preserves signal integrity throughout the signal path by maintaining the signals at the same reference level as the UUT. In addition, meticulous signal routing is done for signal shielding and cross talk reduction, allowing the SMX-4411 to achieve best in class switching performance. This performance allows the card to be used with high frequency signals, and signals that have fast rise times and narrow pulse widths

CONNECTOR PINS AND SIGNALS

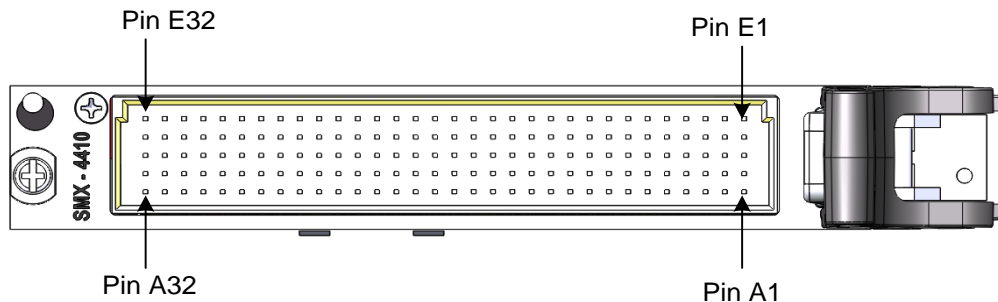

FIGURE 3-75: SMX-4411 FRONT PANEL (FRONT VIEW)

Row A		Row B		Row C		Row D		Row E	
Pin	Signal	Pin	Signal	Pin	Signal	Pin	Signal	Pin	Signal
1	USR_SHIELD	1	USR_SHIELD	1	USR_SHIELD	1	USR_SHIELD	1	USR_SHIELD
2	CH3_C6L	2	CH4_R3H	2	CH4_R2L	2	UNUSED	2	UNUSED
3	CH3_C6H	3	CH3_R3H	3	CH3_R3L	3	CH4_R2H	3	CH4_R2L
4	CH3_C1L	4	CH3_C7H	4	CH3_C7L	4	CH3_R2H	4	CH3_R2L
5	CH3_C1H	5	CH3_C4H	5	CH3_C4L	5	UNUSED	5	UNUSED
6	CH4_C4L	6	CH4_C8H	6	CH4_C8L	6	CH4_C7H	6	CH4_C7L
7	CH4_C4H	7	CH3_C5H	7	CH3_C5L	7	CH3_R1H	7	CH3_R1L
8	CH3_C8L	8	CH4_R1H	8	CH4_R1L	8	UNUSED	8	UNUSED
9	CH3_C8H	9	CH4_R4H	9	CH4_R4L	9	UNUSED	9	UNUSED
10	CH3_C3L	10	CH2_C5H	10	CH2_C5L	10	CH3_R4H	10	CH3_R4L
11	CH3_C3H	11	CH2_C1H	11	CH2_C1L	11	CH4_C10H	11	CH4_C10L
12	CH1_C6L	12	CH3_C2H	12	CH3_C2L	12	CH3_C10H	12	CH3_C10L
13	CH1_C6H	13	CH3_C9H	13	CH3_C9L	13	CH4_C6H	13	CH4_C6L
14	CH4_C3L	14	CH1_C1H	14	CH1_C1L	14	CH4_C5H	14	CH4_C5L
15	CH4_C3H	15	CH2_C4H	15	CH2_C4L	15	CH2_C3H	15	CH2_C3L
16	CH1_C7L	16	CH1_C2H	16	CH1_C2L	16	CH4_C2H	16	CH4_C2L
17	CH1_C7H	17	CH2_R4H	17	CH2_R4L	17	CH4_C9H	17	CH4_C9L
18	CH1_R4L	18	CH2_C10H	18	CH2_C10L	18	UNUSED	18	UNUSED
19	CH1_R4H	19	CH1_C8H	19	CH1_C8L	19	CH1_C3H	19	CH1_C3L
20	CH1_R3L	20	CH2_C9H	20	CH2_C9L	20	UNUSED	20	UNUSED
21	CH1_R3H	21	UNUSED	21	UNUSED	21	UNUSED	21	UNUSED
22	CH1_C9L	22	CH2_C2H	22	CH2_C2L	22	CH2_R3H	22	CH2_R3L
23	CH1_C9H	23	CH1_C4H	23	CH1_C4L	23	UNUSED	23	UNUSED
24	UNUSED	24	CH2_R2H	24	CH2_R2L	24	CH2_C7H	24	CH2_C7L
25	UNUSED	25	UNUSED	25	UNUSED	25	UNUSED	25	UNUSED
26	UNUSED	26	CH2_C8H	26	CH2_C8L	26	CH4_C1H	26	CH4_C1L
27	UNUSED	27	UNUSED	27	UNUSED	27	CH1_R2H	27	CH1_R2L
28	UNUSED	28	CH1_C10H	28	CH1_C10L	28	CH1_R1H	28	CH1_R1L
29	UNUSED	29	CH2_R1H	29	CH2_R1L	29	CH2_C6H	29	CH2_C6L
30	UNUSED	30	UNUSED	30	UNUSED	30	CH1_C5H	30	CH1_C5L
31	UNUSED	31	UNUSED	31	UNUSED	31	UNUSED	31	UNUSED
32	USR_SHIELD	32	USR_SHIELD	32	USR_SHIELD	32	USR_SHIELD	32	USR_SHIELD

TABLE 3-30: SMX-4411 CONNECTOR PINS & SIGNAL ASSIGNMENTS

LOGICAL DIAGRAM

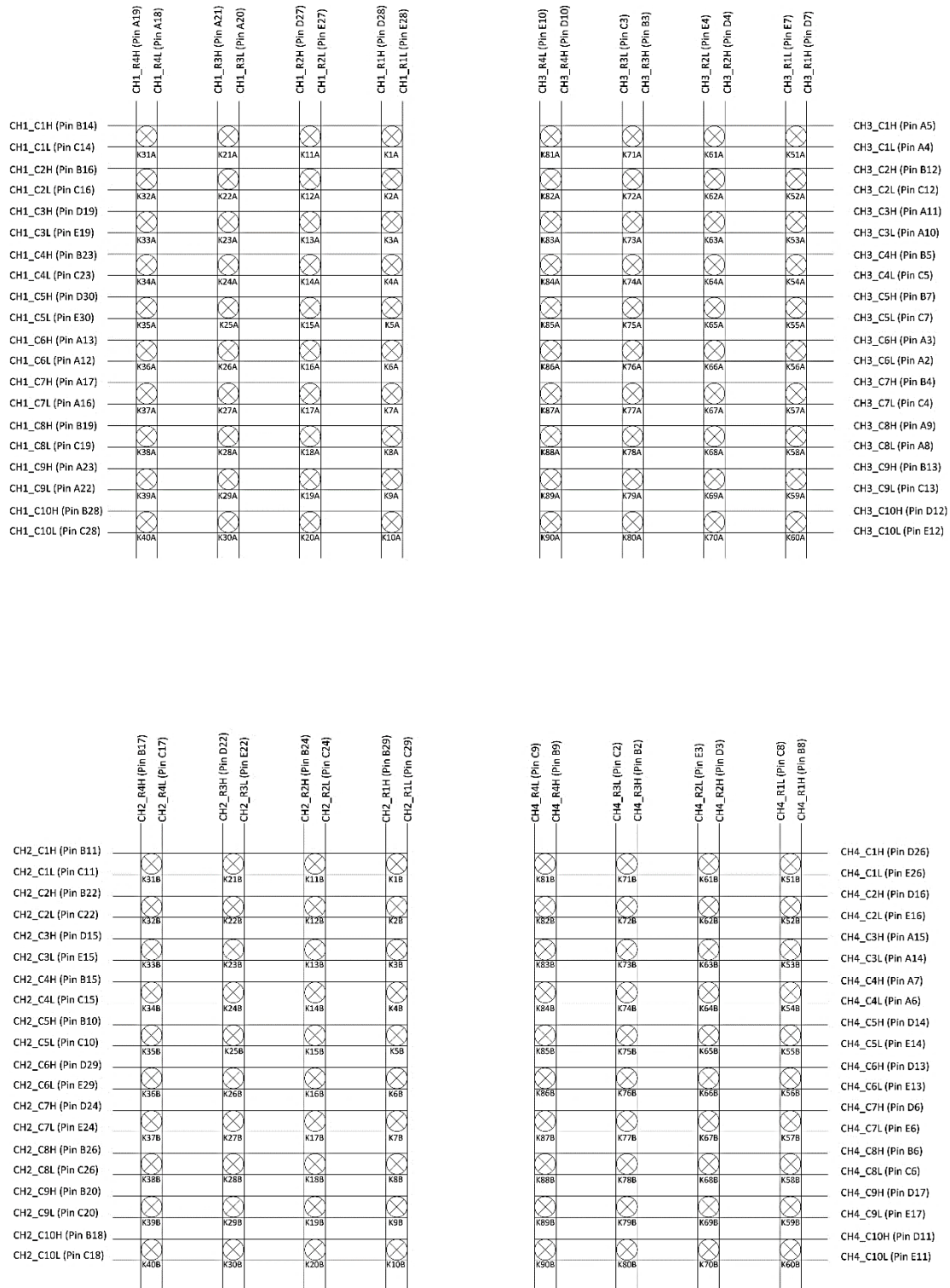

FIGURE 3-76: SMX-4411 LOGICAL DIAGRAM

SMX-4411 SPECIFICATIONS

GENERAL SPECIFICATIONS	
CHANNEL COUNT	(4) 4x10 2-wire Matrices
RELAY TYPE	Electromechanical, fail-safe
MAXIMUM SWITCHING VOLTAGE	300 V dc, 300 V ac
MAXIMUM SWITCHING CURRENT	2 A
MAXIMUM SWITCHING POWER	60 W dc, 62.5 VA
<i>*Maximum switched power is at 30 V/ 2 A dc. Max switched power is derated non-linearly as voltage is increased.</i>	
RATED SWITCH OPERATIONS	
Mechanical	1 x 10 ⁸ (no load)
Electrical	Min. 1 x 10 ⁵ @ (resistive load, 250VAC/0.25A), (resistive load, 30VDC/2A)
SWITCHING TIME	< 8 ms
PATH RESISTANCE	< 500 mΩ
INSULATION RESISTANCE	> 1 x 10 ⁹ Ω
MAXIMUM THERMAL OFFSET PER CHANNEL (HI-LO)	< 10 μV
CAPACITANCE	
Open channel	< 41 pF
Channel-mainframe	< 175 pF
High-low	< 104 pF
BANDWIDTH (-3 dB)	82 MHz (typical), 112 MHz (best), 74 MHz (worst)
CROSSTALK (TYPICAL)	
100 KHz	< -67 dB
1 MHz	< -53 dB
ISOLATION (TYPICAL)	
100 kHz	< -63 dB
1 MHz	< -63 dB
INSERTION LOSS (TYPICAL)	
100 kHz	< 0.07 dB
1 MHz	< 0.12 dB
10MHz	< 0.88 dB

FOR MATING CONNECTOR, CRIMP PINS, AND OTHER ACCESSORIES, PLEASE REFER TO *APPENDIX B*

SMX-4410, MATRIX MODULE

(2) 4x20 2-WIRE FIXED MATRIX

The SMX-4412 is a high-density PXIe matrix module that allows the user to connect any input row to any output column, with a DPST relay at every row/column crosspoint. This architecture provides the framework for flexible switch system designs where multiple test instruments need to be connected to common test points.

The SMX-4412 contains two (4x20) 2-wire matrix providing the user flexibility and simplifying field wiring. The card is capable of switching up to 300V, 2A enabling it to be used over a wide range of applications. It also includes an embedded Self-Test mechanism that can be used to determine relay health.

The SMX-4412 incorporates extensive signal shielding and exposes shield pins on the front panel connector for tying to the cable shield. This preserves signal integrity throughout the signal path by maintaining the signals at the same reference level as the UUT. In addition, meticulous signal routing is done for signal shielding and cross talk reduction, allowing the SMX-4412 to achieve best in class switching performance. This performance allows the card to be used with high frequency signals, and signals that have fast rise times and narrow pulse widths

CONNECTOR PINS AND SIGNALS

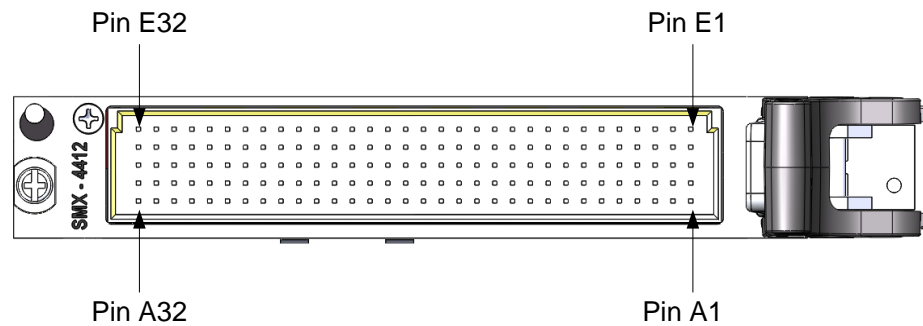

FIGURE 3-77: SMX-4412 FRONT PANEL (FRONT VIEW)

Row A		Row B		Row C		Row D		Row E	
Pin	Signal	Pin	Signal	Pin	Signal	Pin	Signal	Pin	Signal
1	USR_SHIELD	1	USR_SHIELD	1	USR_SHIELD	1	USR_SHIELD	1	USR_SHIELD
2	CH2_C6L	2	UNUSED	2	UNUSED	2	UNUSED	2	UNUSED
3	CH2_C6H	3	CH2_R3H	3	CH2_R3L	3	UNUSED	3	UNUSED
4	CH2_C1L	4	CH2_C7H	4	CH2_C7L	4	CH2_R2H	4	CH2_R2L
5	CH2_C1H	5	CH2_C4H	5	CH2_C4L	5	UNUSED	5	UNUSED
6	CH2_C14L	6	CH2_C18H	6	CH2_C18L	6	CH2_C17H	6	CH2_C17L
7	CH2_C14H	7	CH2_C5H	7	CH2_C5L	7	CH2_R1H	7	CH2_R1L
8	CH2_C8H	8	UNUSED	8	UNUSED	8	UNUSED	8	UNUSED
9	CH2_C8H	9	UNUSED	9	UNUSED	9	UNUSED	9	UNUSED
10	CH2_C3L	10	CH1_C15H	10	CH1_C15L	10	CH2_R4H	10	CH2_R4L
11	CH2_C3H	11	CH1_C11H	11	CH1_C11L	11	CH2_C20H	11	CH2_C20L
12	CH1_C6L	12	CH2_C2H	12	CH2_C2L	12	CH2_C10H	12	CH2_C10L
13	CH1_C6H	13	CH2_C9H	13	CH2_C9L	13	CH2_C16H	13	CH2_C16L
14	CH2_C13L	14	CH1_C1H	14	CH1_C1L	14	CH2_C15H	14	CH2_C15L
15	CH2_C13H	15	CH1_C14H	15	CH1_C14L	15	CH1_C13H	15	CH1_C13L
16	CH1_C7L	16	CH1_C2H	16	CH1_C2L	16	CH2_C12H	16	CH2_C12L
17	CH1_C7H	17	UNUSED	17	UNUSED	17	CH2_C19H	17	CH2_C19L
18	CH1_R4L	18	CH1_C20H	18	CH1_C20L	18	UNUSED	18	UNUSED
19	CH1_R4H	19	CH1_C8H	19	CH1_C8L	19	CH1_C3H	19	CH1_C3L
20	CH1_R3L	20	CH1_C19H	20	CH1_C19L	20	UNUSED	20	UNUSED
21	CH1_R3H	21	UNUSED	21	UNUSED	21	UNUSED	21	UNUSED
22	CH1_C9L	22	CH1_C12H	22	CH1_C12L	22	UNUSED	22	UNUSED
23	CH1_C9H	23	CH1_C4H	23	CH1_C4L	23	UNUSED	23	UNUSED
24	UNUSED	24	UNUSED	24	UNUSED	24	CH1_C17H	24	CH1_C17L
25	UNUSED	25	UNUSED	25	UNUSED	25	UNUSED	25	UNUSED
26	UNUSED	26	CH1_C18H	26	CH1_C18L	26	CH2_C11H	26	CH2_C11L
27	UNUSED	27	UNUSED	27	UNUSED	27	CH1_R2H	27	CH1_R2L
28	UNUSED	28	CH1_C10H	28	CH1_C10L	28	CH1_R1H	28	CH1_R1L
29	UNUSED	29	UNUSED	29	UNUSED	29	CH1_C16H	29	CH1_C16L
30	UNUSED	30	UNUSED	30	UNUSED	30	CH1_C5H	30	CH1_C5L
31	UNUSED	31	UNUSED	31	UNUSED	31	UNUSED	31	UNUSED
32	USR_SHIELD	32	USR_SHIELD	32	USR_SHIELD	32	USR_SHIELD	32	USR_SHIELD

TABLE 3-31: SMX-4412 CONNECTOR PINS & SIGNAL ASSIGNMENTS

LOGICAL DIAGRAM

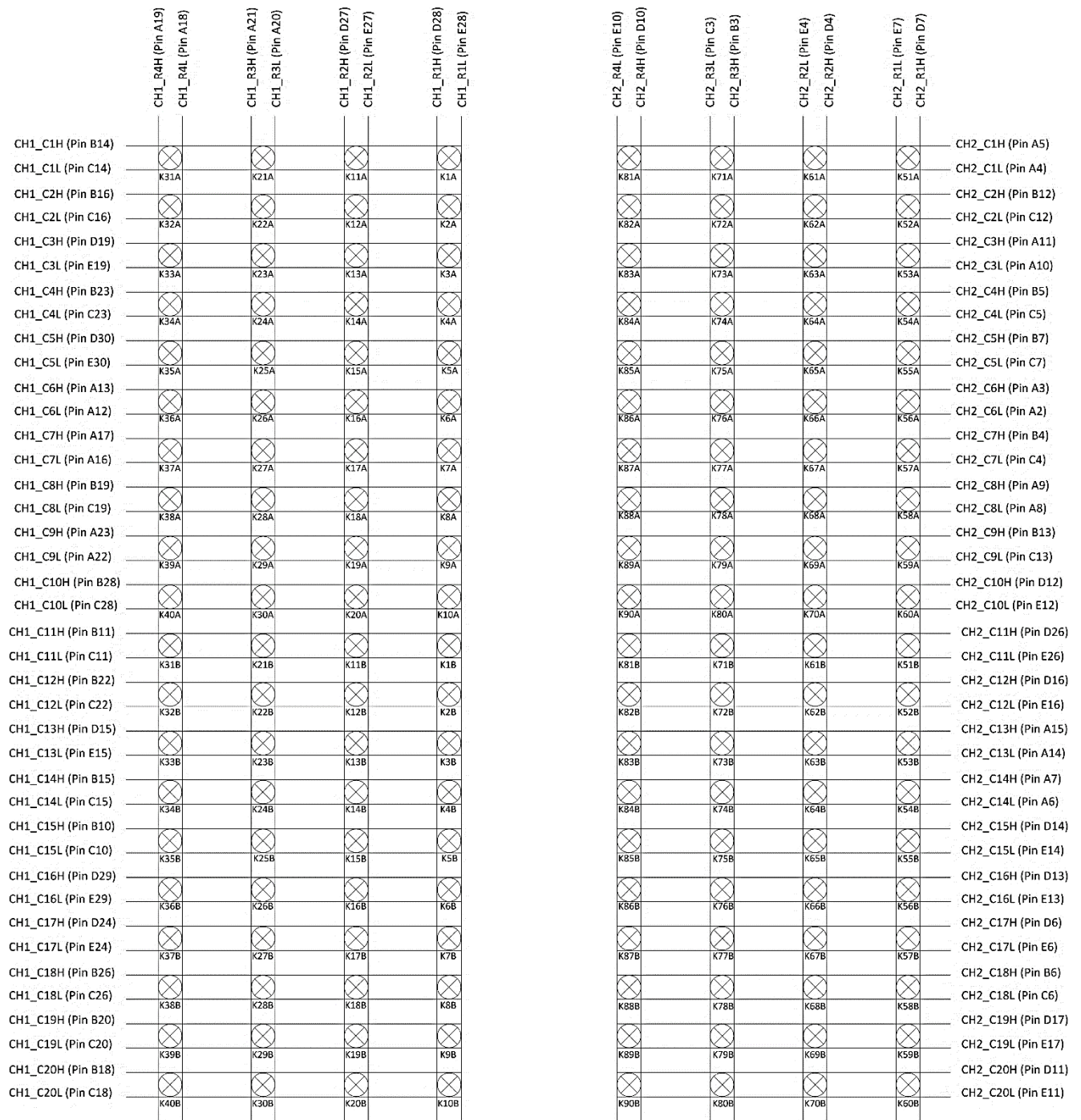

FIGURE 3-78: SMX-4412 LOGICAL DIAGRAM

SMX-4412 SPECIFICATIONS

GENERAL SPECIFICATIONS	
CHANNEL COUNT	(2) 4x20 2-wire Matrices
RELAY TYPE	Electromechanical, fail-safe
MAXIMUM SWITCHING VOLTAGE	300 V dc, 300 V ac
MAXIMUM SWITCHING CURRENT	2 A
MAXIMUM SWITCHING POWER	60 W dc, 62.5 VA
<i>*Maximum switched power is at 30 V/ 2 A dc. Max switched power is derated non-linearly as voltage is increased.</i>	
RATED SWITCH OPERATIONS	
Mechanical	1 x 10 ⁸ (no load)
Electrical	Min. 1 x 10 ⁵ @ (resistive load, 250VAC/0.25A), (resistive load, 30VDC/2A)
SWITCHING TIME	< 8 ms
PATH RESISTANCE	< 500 mΩ
INSULATION RESISTANCE	> 1 x 10 ⁹ Ω
MAXIMUM THERMAL OFFSET PER CHANNEL (HI-LO)	
	< 10 μV
CAPACITANCE	
Open channel	< 41 pF
Channel-mainframe	< 236 pF
High-low	< 158 pF
BANDWIDTH (-3 dB)	
	39 MHz (typical), 40 MHz (best), 37 MHz (worst),
CROSSTALK (TYPICAL)	
100 KHz	< -63 dB
1 MHz	< -44 dB
ISOLATION (TYPICAL)	
100 kHz	< -64 dB
1 MHz	< -57 dB
INSERTION LOSS (TYPICAL)	
100 kHz	< 0.08 dB
1 MHz	< 0.11 dB
10MHz	< 0.36 dB

FOR MATING CONNECTOR, CRIMP PINS, AND OTHER ACCESSORIES, PLEASE REFER TO *APPENDIX B*

SMX-4410, MATRIX MODULE

(1) 4x40 2-WIRE FIXED MATRIX

The SMX-4413 is a high-density PXIe matrix module that allows the user to connect any input row to any output column, with a DPST relay at every row/column crosspoint. This architecture provides the framework for flexible switch system designs where multiple test instruments need to be connected to common test points.

The SMX-4413 contains one (4x40) 2-wire matrix providing the user flexibility and simplifying field wiring. The card is capable of switching up to 300V, 2A enabling it to be used over a wide range of applications. It also includes an embedded Self-Test mechanism that can be used to determine relay health.

The SMX-4413 incorporates extensive signal shielding and exposes shield pins on the front panel connector for tying to the cable shield. This preserves signal integrity throughout the signal path by maintaining the signals at the same reference level as the UUT. In addition, meticulous signal routing is done for signal shielding and cross talk reduction, allowing the SMX-4413 to achieve best in class switching performance. This performance allows the card to be used with high frequency signals, and signals that have fast rise times and narrow pulse widths

CONNECTOR PINS AND SIGNALS

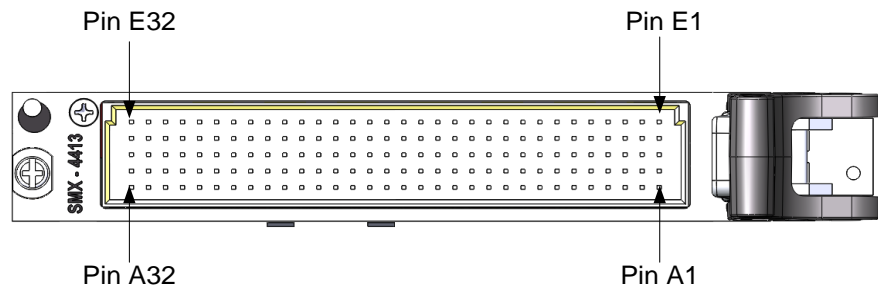

FIGURE 3-79: SMX-4413 FRONT PANEL (FRONT VIEW)

Row A		Row B		Row C		Row D		Row E	
Pin	Signal	Pin	Signal	Pin	Signal	Pin	Signal	Pin	Signal
1	USR_SHIELD	1	USR_SHIELD	1	USR_SHIELD	1	USR_SHIELD	1	USR_SHIELD
2	CH_C35L	2	UNUSED	2	UNUSED	2	UNUSED	2	UNUSED
3	CH_C35H	3	UNUSED	3	UNUSED	3	UNUSED	3	UNUSED
4	CH_C40L	4	CH_C34H	4	CH_C34L	4	UNUSED	4	UNUSED
5	CH_C40H	5	CH_C37H	5	CH_C37L	5	UNUSED	5	UNUSED
6	CH_C27L	6	CH_C23H	6	CH_C23L	6	CH_C24H	6	CH_C24L
7	CH_C27H	7	CH_C36H	7	CH_C36L	7	UNUSED	7	UNUSED
8	CH_C33L	8	UNUSED	8	UNUSED	8	UNUSED	8	UNUSED
9	CH_C33H	9	UNUSED	9	UNUSED	9	UNUSED	9	UNUSED
10	CH_C38L	10	CH_C15H	10	CH_C15L	10	UNUSED	10	UNUSED
11	CH_C38H	11	CH_C11H	11	CH_C11L	11	CH_C21H	11	CH_C21L
12	CH_C6L	12	CH_C39H	12	CH_C39L	12	CH_C31H	12	CH_C31L
13	CH_C6H	13	CH_C32H	13	CH_C32L	13	CH_C25H	13	CH_C25L
14	CH_C28L	14	CH_C1H	14	CH_C1L	14	CH_C26H	14	CH_C26L
15	CH_C28H	15	CH_C14H	15	CH_C14L	15	CH_C13H	15	CH_C13L
16	CH_C7L	16	CH_C2H	16	CH_C2L	16	CH_C29H	16	CH_C29L
17	CH_C7H	17	UNUSED	17	UNUSED	17	CH_C22H	17	CH_C22L
18	UNUSED	18	CH_C20H	18	CH_C20L	18	CH_R3H	18	CH_R3L
19	UNUSED	19	CH_C8H	19	CH_C8L	19	CH_C3H	19	CH_C3L
20	UNUSED	20	CH_C19H	20	CH_C19L	20	CH_R4H	20	CH_R4L
21	UNUSED	21	UNUSED	21	UNUSED	21	CH_R2H	21	CH_R2L
22	CH_C9L	22	CH_C12H	22	CH_C12L	22	UNUSED	22	UNUSED
23	CH_C9H	23	CH_C4H	23	CH_C4L	23	CH_R1H	23	CH_R1L
24	UNUSED	24	UNUSED	24	UNUSED	24	CH_C17H	24	CH_C17L
25	UNUSED	25	UNUSED	25	UNUSED	25	UNUSED	25	UNUSED
26	UNUSED	26	CH_C18H	26	CH_C18L	26	CH_C30H	26	CH_C30L
27	UNUSED	27	UNUSED	27	UNUSED	27	UNUSED	27	UNUSED
28	UNUSED	28	CH_C10H	28	CH_C10L	28	UNUSED	28	UNUSED
29	UNUSED	29	UNUSED	29	UNUSED	29	CH_C16H	29	CH_C16L
30	UNUSED	30	UNUSED	30	UNUSED	30	CH_C5H	30	CH_C5L
31	UNUSED	31	UNUSED	31	UNUSED	31	UNUSED	31	UNUSED
32	USR_SHIELD	32	USR_SHIELD	32	USR_SHIELD	32	USR_SHIELD	32	USR_SHIELD

TABLE 3-32: SMX-4413 CONNECTOR PINS & SIGNAL ASSIGNMENTS

LOGICAL DIAGRAM

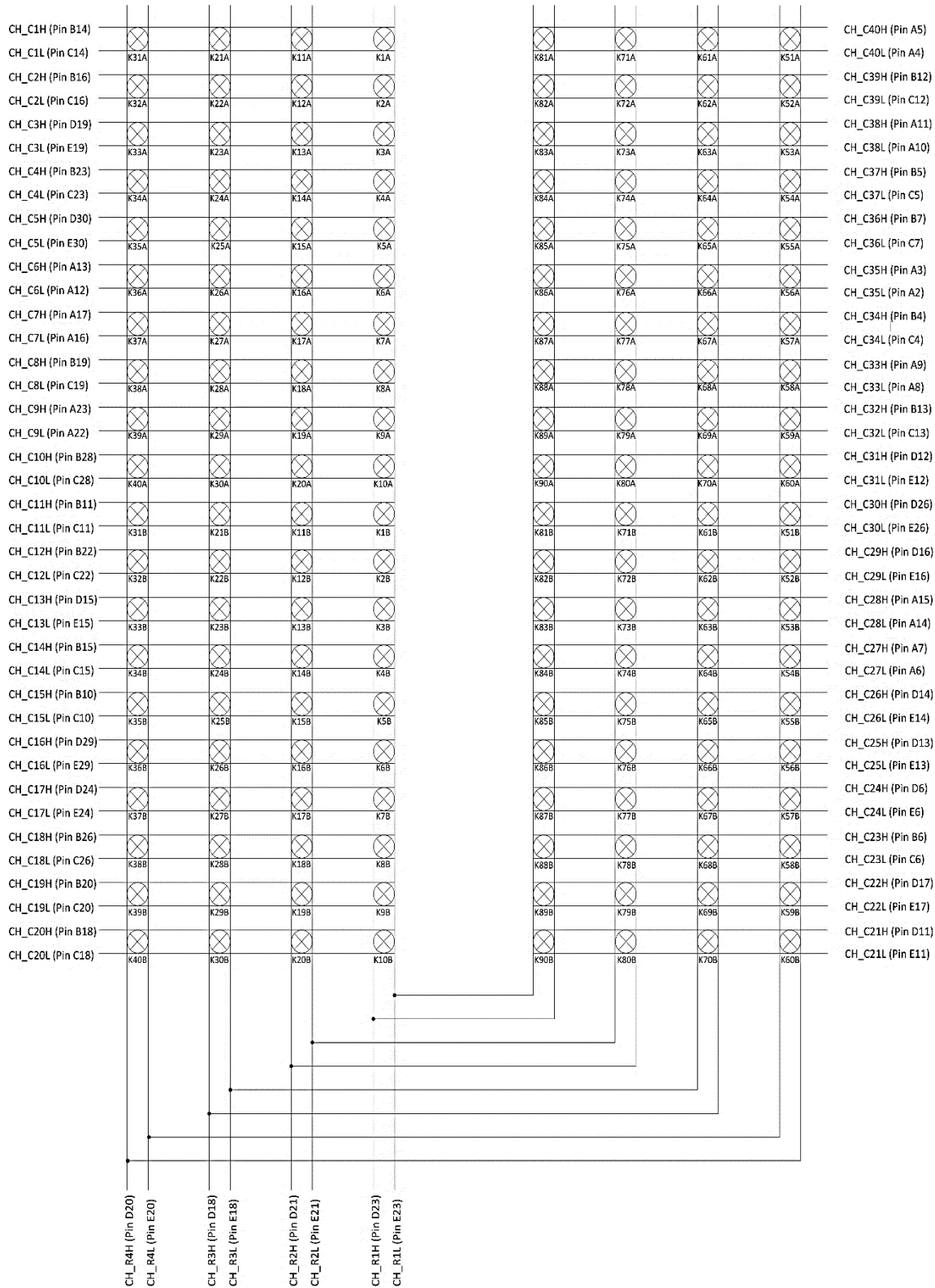

FIGURE 3-80: SMX-4413 LOGICAL DIAGRAM

SMX-4413 SPECIFICATIONS

GENERAL SPECIFICATIONS	
CHANNEL COUNT	(1) 4x40 2-wire Matrices
RELAY TYPE	Electromechanical, fail-safe
MAXIMUM SWITCHING VOLTAGE	300 V dc, 300 V ac
MAXIMUM SWITCHING CURRENT	2 A
MAXIMUM SWITCHING POWER	60 W dc, 62.5 VA
<i>*Maximum switched power is at 30 V/ 2 A dc. Max switched power is derated non-linearly as voltage is increased.</i>	
RATED SWITCH OPERATIONS	
Mechanical	1 x 10 ⁸ (no load)
Electrical	Min. 1 x 10 ⁵ @ (resistive load, 250VAC/0.25A), (resistive load, 30VDC/2A)
SWITCHING TIME	< 8 ms
PATH RESISTANCE	< 600 mΩ
INSULATION RESISTANCE	> 1 x 10 ⁹ Ω
MAXIMUM THERMAL OFFSET PER CHANNEL (HI-LO)	< 10 μV
CAPACITANCE	
Open channel	< 41 pF
Channel-mainframe	< 330 pF
High-low	< 246 pF
BANDWIDTH (-3 dB)	31 MHz (typical), 35 MHz (best), 28 MHz (worst),
CROSSTALK (TYPICAL)	
100 kHz	< -68 dB
1 MHz	< -55 dB
ISOLATION (TYPICAL)	
100 kHz	< -62 dB
1 MHz	< -55 dB
INSERTION LOSS (TYPICAL)	
100 kHz	< 0.2 dB
1 MHz	< 0.25 dB
10MHz	< 0.75 dB

FOR MATING CONNECTOR, CRIMP PINS, AND OTHER ACCESSORIES, PLEASE REFER TO APPENDIX B

SMX-4410, MATRIX MODULE

(2) 8x10 2-WIRE FIXED MATRIX

The SMX-4414 is a high-density PXIe matrix module that allows the user to connect any input row to any output column, with a DPST relay at every row/column crosspoint. This architecture provides the framework for flexible switch system designs where multiple test instruments need to be connected to common test points.

The SMX-4414 contains two (8x10) 2-wire matrix providing the user flexibility and simplifying field wiring. The card is capable of switching up to 300V, 2A enabling it to be used over a wide range of applications. It also includes an embedded Self-Test mechanism that can be used to determine relay health.

The SMX-4414 incorporates extensive signal shielding and exposes shield pins on the front panel connector for tying to the cable shield. This preserves signal integrity throughout the signal path by maintaining the signals at the same reference level as the UUT. In addition, meticulous signal routing is done for signal shielding and cross talk reduction, allowing the SMX-4414 to achieve best in class switching performance. This performance allows the card to be used with high frequency signals, and signals that have fast rise times and narrow pulse widths

CONNECTOR PINS AND SIGNALS

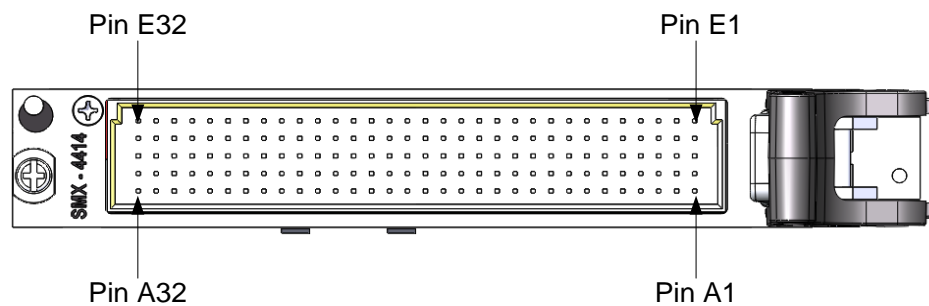

FIGURE 3-81: SMX-4414 FRONT PANEL (FRONT VIEW)

Row A		Row B		Row C		Row D		Row E	
Pin	Signal	Pin	Signal	Pin	Signal	Pin	Signal	Pin	Signal
1	USR_SHIELD	1	USR_SHIELD	1	USR_SHIELD	1	USR_SHIELD	1	USR_SHIELD
2	UNUSED	2	CH2_R7H	2	CH2_R7L	2	UNUSED	2	UNUSED
3	UNUSED	3	CH1_R7H	3	CH1_R7L	3	CH2_R6H	3	CH2_R6L
4	UNUSED	4	UNUSED	4	UNUSED	4	CH1_R6H	4	CH1_R6L
5	UNUSED	5	UNUSED	5	UNUSED	5	UNUSED	5	UNUSED
6	UNUSED	6	UNUSED	6	UNUSED	6	UNUSED	6	UNUSED
7	UNUSED	7	UNUSED	7	UNUSED	7	CH1_R5H	7	CH1_R5L
8	UNUSED	8	CH2_R5H	8	CH2_R5L	8	UNUSED	8	UNUSED
9	UNUSED	9	CH2_R8H	9	CH2_R8L	9	UNUSED	9	UNUSED
10	UNUSED	10	CH2_C5H	10	CH2_C5L	10	CH1_R8H	10	CH1_R8L
11	UNUSED	11	CH2_C1H	11	CH2_C1L	11	UNUSED	11	UNUSED
12	CH1_C6L	12	UNUSED	12	UNUSED	12	UNUSED	12	UNUSED
13	CH1_C6H	13	UNUSED	13	UNUSED	13	UNUSED	13	UNUSED
14	UNUSED	14	CH1_C1H	14	CH1_C1L	14	UNUSED	14	UNUSED
15	UNUSED	15	CH2_C4H	15	CH2_C4L	15	CH2_C3H	15	CH2_C3L
16	CH1_C7L	16	CH1_C2H	16	CH1_C2L	16	UNUSED	16	UNUSED
17	CH1_C7H	17	CH2_R4H	17	CH2_R4L	17	UNUSED	17	UNUSED
18	CH1_R4L	18	CH2_C10H	18	CH2_C10L	18	UNUSED	18	UNUSED
19	CH1_R4H	19	CH1_C8H	19	CH1_C8L	19	CH1_C3H	19	CH1_C3L
20	CH1_R3L	20	CH2_C9H	20	CH2_C9L	20	UNUSED	20	UNUSED
21	CH1_R3H	21	UNUSED	21	UNUSED	21	UNUSED	21	UNUSED
22	CH1_C9L	22	CH2_C2H	22	CH2_C2L	22	CH2_R3H	22	CH2_R3L
23	CH1_C9H	23	CH1_C4H	23	CH1_C4L	23	UNUSED	23	UNUSED
24	UNUSED	24	CH2_R2H	24	CH2_R2L	24	CH2_C7H	24	CH2_C7L
25	UNUSED	25	UNUSED	25	UNUSED	25	UNUSED	25	UNUSED
26	UNUSED	26	CH2_C8H	26	CH2_C8L	26	UNUSED	26	UNUSED
27	UNUSED	27	UNUSED	27	UNUSED	27	CH1_R2H	27	CH1_R2L
28	UNUSED	28	CH1_C10H	28	CH1_C10L	28	CH1_R1H	28	CH1_R1L
29	UNUSED	29	CH2_R1H	29	CH2_R1L	29	CH2_C6H	29	CH2_C6L
30	UNUSED	30	UNUSED	30	UNUSED	30	CH1_C5H	30	CH1_C5L
31	UNUSED	31	UNUSED	31	UNUSED	31	UNUSED	31	UNUSED
32	USR_SHIELD	32	USR_SHIELD	32	USR_SHIELD	32	USR_SHIELD	32	USR_SHIELD

TABLE 3-33: SMX-4414 CONNECTOR PINS & SIGNAL ASSIGNMENTS

SMX-4414 SPECIFICATIONS

GENERAL SPECIFICATIONS	
CHANNEL COUNT	(2) 8x10 2-wire Matrices
RELAY TYPE	Electromechanical, fail-safe
MAXIMUM SWITCHING VOLTAGE	300 V dc, 300 V ac
MAXIMUM SWITCHING CURRENT	2 A
MAXIMUM SWITCHING POWER	60 W dc, 62.5 VA
<i>*Maximum switched power is at 30 V/ 2 A dc. Max switched power is derated non-linearly as voltage is increased.</i>	
RATED SWITCH OPERATIONS	
Mechanical	1 x 10 ⁸ (no load)
Electrical	Min. 1 x 10 ⁵ @ (resistive load, 250VAC/0.25A), (resistive load, 30VDC/2A)
SWITCHING TIME	< 8 ms
PATH RESISTANCE	< 500 mΩ
INSULATION RESISTANCE	> 1 x 10 ⁹ Ω
MAXIMUM THERMAL OFFSET PER CHANNEL (HI-LO)	< 10 μV
CAPACITANCE	
Open channel	< 66 pF
Channel-mainframe	< 210 pF
High-low	< 131 pF
BANDWIDTH (-3 dB)	74 MHz (typical), 96 MHz (best), 66 MHz (worst),
CROSSTALK (TYPICAL)	
100 kHz	< -62 dB
1 MHz	< -40 dB
ISOLATION (TYPICAL)	
100 kHz	< -78 dB
1 MHz	< -47 dB
INSERTION LOSS (TYPICAL)	
100 kHz	< 0.16 dB
1 MHz	< 0.21 dB
10MHz	< 0.92 dB

FOR MATING CONNECTOR, CRIMP PINS, AND OTHER ACCESSORIES, PLEASE REFER TO APPENDIX B

SMX-4410, MATRIX MODULE

(1) 8x20 2-WIRE FIXED MATRIX

The SMX-4415 is a high-density PXIe matrix module that allows the user to connect any input row to any output column, with a DPST relay at every row/column crosspoint. This architecture provides the framework for flexible switch system designs where multiple test instruments need to be connected to common test points.

The SMX-4415 contains one (8x20) 2-wire matrix providing the user flexibility and simplifying field wiring. The card is capable of switching up to 300V, 2A enabling it to be used over a wide range of applications. It also includes an embedded Self-Test mechanism that can be used to determine relay health.

The SMX-4415 incorporates extensive signal shielding and exposes shield pins on the front panel connector for tying to the cable shield. This preserves signal integrity throughout the signal path by maintaining the signals at the same reference level as the UUT. In addition, meticulous signal routing is done for signal shielding and cross talk reduction, allowing the SMX-4415 to achieve best in class switching performance. This performance allows the card to be used with high frequency signals, and signals that have fast rise times and narrow pulse widths

CONNECTOR PINS AND SIGNALS

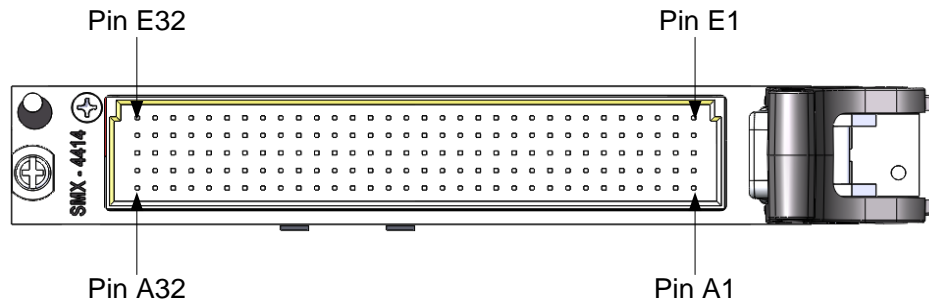

FIGURE 3-83: SMX-4415 FRONT PANEL (FRONT VIEW)

Row A		Row B		Row C		Row D		Row E	
Pin	Signal	Pin	Signal	Pin	Signal	Pin	Signal	Pin	Signal
1	USR_SHIELD	1	USR_SHIELD	1	USR_SHIELD	1	USR_SHIELD	1	USR_SHIELD
2	UNUSED	2	UNUSED	2	UNUSED	2	UNUSED	2	UNUSED
3	UNUSED	3	CH_R7H	3	CH_R7L	3	UNUSED	3	UNUSED
4	UNUSED	4	UNUSED	4	UNUSED	4	CH_R6H	4	CH_R6L
5	UNUSED	5	UNUSED	5	UNUSED	5	UNUSED	5	UNUSED
6	UNUSED	6	UNUSED	6	UNUSED	6	UNUSED	6	UNUSED
7	UNUSED	7	UNUSED	7	UNUSED	7	CH_R5H	7	CH_R5L
8	UNUSED	8	UNUSED	8	UNUSED	8	UNUSED	8	UNUSED
9	UNUSED	9	UNUSED	9	UNUSED	9	UNUSED	9	UNUSED
10	UNUSED	10	CH_C15H	10	CH_C15L	10	CH_R8H	10	CH_R8L
11	UNUSED	11	CH_C11H	11	CH_C11L	11	UNUSED	11	UNUSED
12	CH_C6L	12	UNUSED	12	UNUSED	12	UNUSED	12	UNUSED
13	CH_C6H	13	UNUSED	13	UNUSED	13	UNUSED	13	UNUSED
14	UNUSED	14	CH_C1H	14	CH_C1L	14	UNUSED	14	UNUSED
15	UNUSED	15	CH_C14H	15	CH_C14L	15	CH_C13H	15	CH_C13L
16	CH_C7L	16	CH_C2H	16	CH_C2L	16	UNUSED	16	UNUSED
17	CH_C7H	17	UNUSED	17	UNUSED	17	UNUSED	17	UNUSED
18	CH_R4L	18	CH_C20H	18	CH_C20L	18	UNUSED	18	UNUSED
19	CH_R4H	19	CH_C8H	19	CH_C8L	19	CH_C3H	19	CH_C3L
20	CH_R3L	20	CH_C19H	20	CH_C19L	20	UNUSED	20	UNUSED
21	CH_R3H	21	UNUSED	21	UNUSED	21	UNUSED	21	UNUSED
22	CH_C9L	22	CH_C12H	22	CH_C12L	22	UNUSED	22	UNUSED
23	CH_C9H	23	CH_C4H	23	CH_C4L	23	UNUSED	23	UNUSED
24	UNUSED	24	UNUSED	24	UNUSED	24	CH_C17H	24	CH_C17L
25	UNUSED	25	UNUSED	25	UNUSED	25	UNUSED	25	UNUSED
26	UNUSED	26	CH_C18H	26	CH_C18L	26	UNUSED	26	UNUSED
27	UNUSED	27	UNUSED	27	UNUSED	27	CH_R2H	27	CH_R2L
28	UNUSED	28	CH_C10H	28	CH_C10L	28	CH_R1H	28	CH_R1L
29	UNUSED	29	UNUSED	29	UNUSED	29	CH_C16H	29	CH_C16L
30	UNUSED	30	UNUSED	30	UNUSED	30	CH_C5H	30	CH_C5L
31	UNUSED	31	UNUSED	31	UNUSED	31	UNUSED	31	UNUSED
32	USR_SHIELD	32	USR_SHIELD	32	USR_SHIELD	32	USR_SHIELD	32	USR_SHIELD

TABLE 3-34: SMX-4415 CONNECTOR PINS & SIGNAL ASSIGNMENTS

LOGICAL DIAGRAM

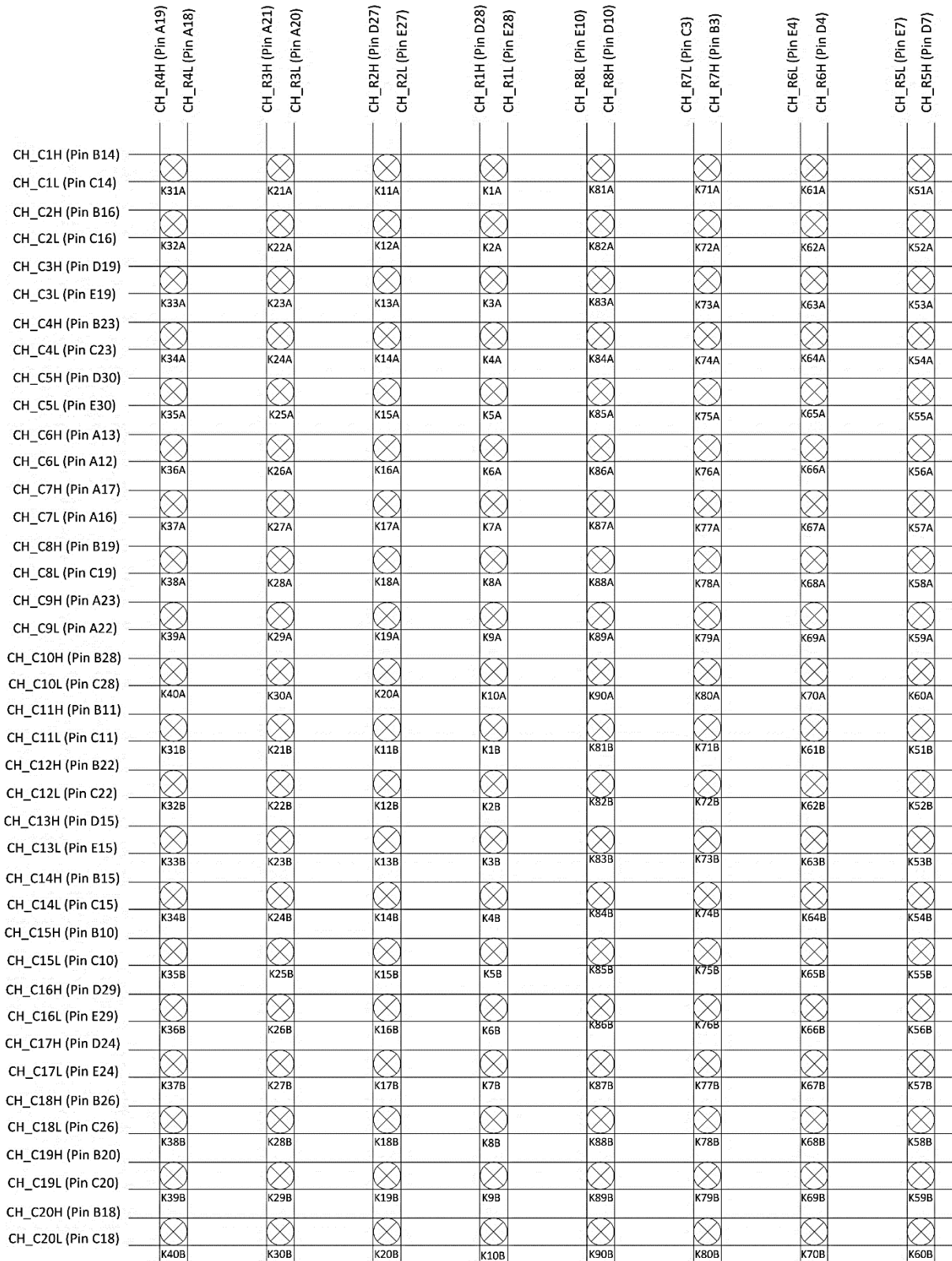

FIGURE 3-84: SMX-4415 LOGICAL DIAGRAM

SMX-4415 SPECIFICATIONS

GENERAL SPECIFICATIONS	
CHANNEL COUNT	(1) 8x20 2-wire Matrices
RELAY TYPE	Electromechanical, fail-safe
MAXIMUM SWITCHING VOLTAGE	300 V dc, 300 V ac
MAXIMUM SWITCHING CURRENT	2 A
MAXIMUM SWITCHING POWER	60 W dc, 62.5 VA
<i>*Maximum switched power is at 30 V/ 2 A dc. Max switched power is derated non-linearly as voltage is increased.</i>	
RATED SWITCH OPERATIONS	
Mechanical	1 x 10 ⁸ (no load)
Electrical	Min. 1 x 10 ⁵ @ (resistive load, 250VAC/0.25A), (resistive load, 30VDC/2A)
SWITCHING TIME	< 8 ms
PATH RESISTANCE	< 500 mΩ
INSULATION RESISTANCE	> 1 x 10 ⁹ Ω
MAXIMUM THERMAL OFFSET PER CHANNEL (HI-LO)	
	< 10 μV
CAPACITANCE	
Open channel	< 66 pF
Channel-mainframe	< 312 pF
High-low	< 185 pF
BANDWIDTH (-3 dB)	
	61 MHz (typical), 64 MHz (best), 54 MHz (worst)
CROSSTALK (TYPICAL)	
100 KHz	< -68 dB
1 MHz	< -55 dB
ISOLATION (TYPICAL)	
100 kHz	< -77 dB
1 MHz	< -40 dB
INSERTION LOSS (TYPICAL)	
100 kHz	< 0.16 dB
1 MHz	< 0.23 dB
10MHz	< 0.92 dB

FOR MATING CONNECTOR, CRIMP PINS, AND OTHER ACCESSORIES, PLEASE REFER TO *APPENDIX B*

SMX-5001 PLUG-IN MODULE

80-CHANNEL 2 AMP FORM A (SPST) SWITCH

The SMX-5001 is a high-density general purpose 2 A switch modules designed for systems where individual relays can be used to route signals to/from the units under test (UUT) or combined externally to form user-defined configurations. These relays are commonly used to create complex signal distribution networks that can be reconfigured through different wiring in test adapters. The modules can also be configured with other SMX series switch modules as part of a flexible system switch design.

The SMX-5001 can be controlled programmatically using IviSwch-compliant calls. Both path level programming and individual relay control are available. Refer to the host driver documentation for additional details. Figure 3-86 provides a logical diagram of the switch module and identifies the switches used by the module. This information can be used for individual relay control through the driver.

CONNECTOR PINS AND SIGNALS

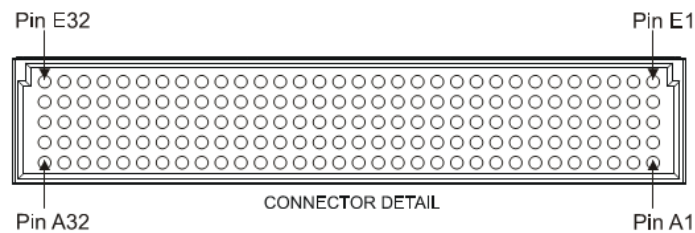

FIGURE 3-85: SMX-5001 FRONT PANEL (FRONT VIEW)

Row A		Row B		Row C		Row D		Row E	
Pin	Signal	Pin	Signal	Pin	Signal	Pin	Signal	Pin	Signal
1	CH_1A	1	CH_2A	1	CH_3A	1	CH_4A	1	CH_5A
2	CH_1B	2	CH_2B	2	CH_3B	2	CH_4B	2	CH_5B
3	CH_6A	3	CH_7A	3	CH_8A	3	CH_9A	3	CH_10A
4	CH_6B	4	CH_7B	4	CH_8B	4	CH_9B	4	CH_10B
5	CH_11A	5	CH_12A	5	CH_13A	5	CH_14A	5	CH_15A
6	CH_11B	6	CH_12B	6	CH_13B	6	CH_14B	6	CH_15B
7	CH_16A	7	CH_17A	7	CH_18A	7	CH_19A	7	CH_20A
8	CH_16B	8	CH_17B	8	CH_18B	8	CH_19B	8	CH_20B
9	CH_21A	9	CH_22A	9	CH_23A	9	CH_24A	9	CH_25A
10	CH_21B	10	CH_22B	10	CH_23B	10	CH_24B	10	CH_25B
11	CH_26A	11	CH_27A	11	CH_28A	11	CH_29A	11	CH_30A
12	CH_26B	12	CH_27B	12	CH_28B	12	CH_29B	12	CH_30B
13	CH_31A	13	CH_32A	13	CH_33A	13	CH_34A	13	CH_35A
14	CH_31B	14	CH_32B	14	CH_33B	14	CH_34B	14	CH_35B
15	CH_36A	15	CH_37A	15	CH_38A	15	CH_39A	15	CH_40A
16	CH_36B	16	CH_37B	16	CH_38B	16	CH_39B	16	CH_40B
17	CH_41A	17	CH_42A	17	CH_43A	17	CH_44A	17	CH_45A
18	CH_41B	18	CH_42B	18	CH_43B	18	CH_44B	18	CH_45B
19	CH_46A	19	CH_47A	19	CH_48A	19	CH_49A	19	CH_50A
20	CH_46B	20	CH_47B	20	CH_48B	20	CH_49B	20	CH_50B
21	CH_51A	21	CH_52A	21	CH_53A	21	CH_54A	21	CH_55A
22	CH_51B	22	CH_52B	22	CH_53B	22	CH_54B	22	CH_55B
23	CH_56A	23	CH_57A	23	CH_58A	23	CH_59A	23	CH_60A
24	CH_56B	24	CH_57B	24	CH_58B	24	CH_59B	24	CH_60B
25	CH_61A	25	CH_62A	25	CH_63A	25	CH_64A	25	CH_65A
26	CH_61B	26	CH_62B	26	CH_63B	26	CH_64B	26	CH_65B
27	CH_66A	27	CH_67A	27	CH_68A	27	CH_69A	27	CH_70A
28	CH_66B	28	CH_67B	28	CH_68B	28	CH_69B	28	CH_70B
29	CH_71A	29	CH_72A	29	CH_73A	29	CH_74A	29	CH_75A
30	CH_71B	30	CH_72B	30	CH_73B	30	CH_74B	30	CH_75B
31	CH_76A	31	CH_77A	31	CH_78A	31	CH_79A	31	CH_80A
32	CH_76B	32	CH_77B	32	CH_78B	32	CH_79B	32	CH_80B

TABLE 3-35: CONNECTOR PINS & SIGNAL ASSIGNMENTS

LOGICAL DIAGRAM

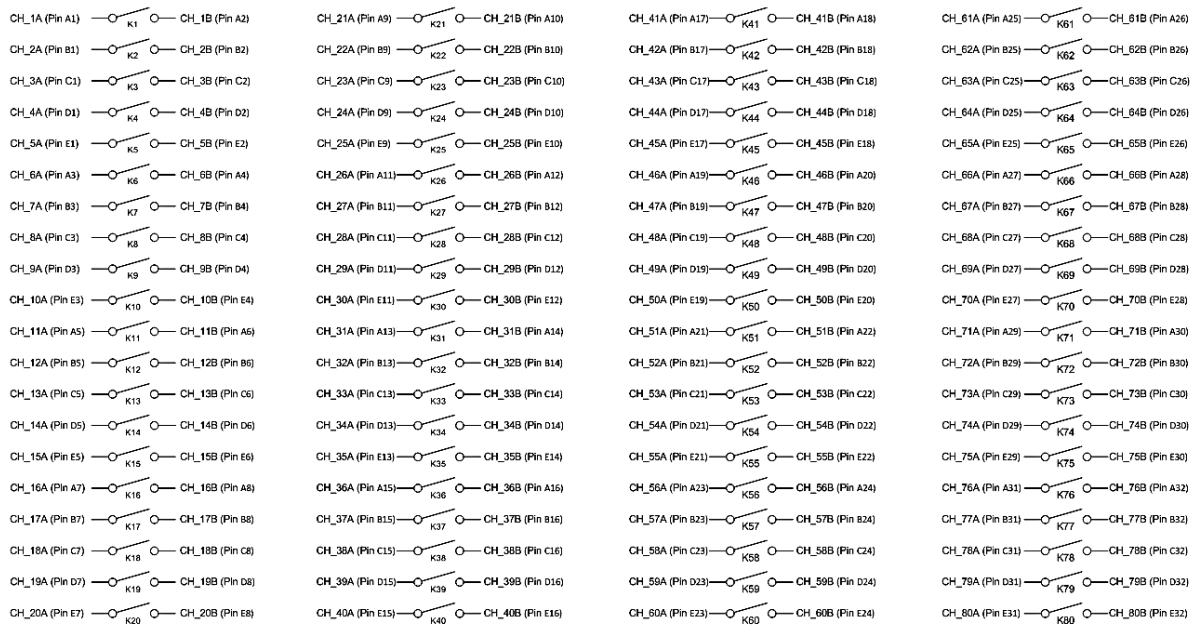

FIGURE 3-86: SMX-5001 LOGICAL DIAGRAM

TB Ref	Signal	Conn Pin	TB Ref	Signal	Conn Pin	TB Ref	Signal	Conn Pin	TB Ref	Signal	Conn Pin	TB Ref	Signal	Conn Pin
T158	CH_1A	A1	T156	CH_2A	B1	T160	CH_3A	C1	T77	CH_4A	D1	T96	CH_5A	E1
T62	CH_1B	A2	T20	CH_2B	B2	T19	CH_3B	C2	T2	CH_4B	D2	T1	CH_5B	E2
T61	CH_6A	A3	T18	CH_7A	B3	T17	CH_8A	C3	T48	CH_9A	D3	T3	CH_10A	E3
T60	CH_6B	A4	T22	CH_7B	B4	T21	CH_8B	C4	T64	CH_9B	D4	T5	CH_10B	E4
T59	CH_11A	A5	T24	CH_12A	B5	T23	CH_13A	C5	T8	CH_14A	D5	T7	CH_15A	E5
T58	CH_11B	A6	T26	CH_12B	B6	T25	CH_13B	C6	T10	CH_14B	D6	T96	CH_15B	E6
T57	CH_16A	A7	T28	CH_17A	B7	T27	CH_18A	C7	T12	CH_19A	D7	T11	CH_20A	E7
T56	CH_16B	A8	T30	CH_17B	B8	T29	CH_18B	C8	T14	CH_19B	D8	T13	CH_20B	E8
T55	CH_21A	A9	T32	CH_22A	B9	T31	CH_23A	C9	T16	CH_24A	D9	T15	CH_25A	E9
T45	CH_21B	A10	T63	CH_22B	B10	T64	CH_23B	C10	T46	CH_24B	D10	T47	CH_25B	E10
T50	CH_26A	A11	T49	CH_27A	B11	T48	CH_28A	C11	T34	CH_29A	D11	T33	CH_30A	E11
T44	CH_26B	A12	T51	CH_27B	B12	T52	CH_28B	C12	T35	CH_29B	D12	T36	CH_30B	E12
T43	CH_31A	A13	T53	CH_32A	B13	T54	CH_33A	C13	T37	CH_34A	D13	T38	CH_35A	E13
T42	CH_31B	A14	T82	CH_32B	B14	T81	CH_33B	C14	T39	CH_34B	D14	T40	CH_35B	E14
T41	CH_36A	A15	T84	CH_37A	B15	T83	CH_38A	C15	T66	CH_39A	D15	T65	CH_40A	E15
T126	CH_36B	A16	T86	CH_37B	B16	T85	CH_38B	C16	T68	CH_39B	D16	T67	CH_40B	E16
T127	CH_41A	A17	T88	CH_42A	B17	T87	CH_43A	C17	T70	CH_44A	D17	T69	CH_45A	E17
T124	CH_41B	A18	T90	CH_42B	B18	T89	CH_43B	C18	T72	CH_44B	D18	T71	CH_45B	E18
T125	CH_46A	A19	T92	CH_47A	B19	T91	CH_48A	C19	T74	CH_49A	D19	T73	CH_50A	E19
T123	CH_46B	A20	T94	CH_47B	B20	T93	CH_48B	C20	T112	CH_49B	D20	T111	CH_50B	E20
T78	CH_51A	A21	T76	CH_52A	B21	T75	CH_53A	C21	T79	CH_54A	D21	T80	CH_55A	E21
T121	CH_51B	A22	T114	CH_52B	B22	T113	CH_53B	C22	T108	CH_54B	D22	T107	CH_55B	E22
T122	CH_56A	A23	T116	CH_57A	B23	T115	CH_58A	C23	T106	CH_59A	D23	T105	CH_60A	E23
T119	CH_56B	A24	T118	CH_57B	B24	T117	CH_58B	C24	T100	CH_59B	D24	T99	CH_60B	E24
T120	CH_61A	A25	T144	CH_62A	B25	T143	CH_63A	C25	T109	CH_64A	D25	T110	CH_65A	E25
T149	CH_61B	A26	T147	CH_62B	B26	T148	CH_63B	C26	T98	CH_64B	D26	T97	CH_65B	E26
T150	CH_66A	A27	T145	CH_67A	B27	T146	CH_68A	C27	T102	CH_69A	D27	T101	CH_70A	E27
T151	CH_66B	A28	T141	CH_67B	B28	T142	CH_68B	C28	T104	CH_69B	D28	T103	CH_70B	E28
T152	CH_71A	A29	T139	CH_72A	B29	T140	CH_73A	C29	T132	CH_74A	D29	T131	CH_75A	E29
T153	CH_71B	A30	T136	CH_72B	B30	T135	CH_73B	C30	T130	CH_74B	D30	T129	CH_75B	E30
T154	CH_76A	A31	T138	CH_77A	B31	T137	CH_78A	C31	T134	CH_79A	D31	T133	CH_80A	E31
T157	CH_76B	A32	T159	CH_77B	B32	T95	CH_78B	C32	T128	CH_79B	D32	T155	CH_80B	E32

TABLE 3-36: EX1200-TB160SE TERMINAL BLOCK TO SMX-5001 PIN MAPPING

SMX-5001 SPECIFICATIONS

GENERAL SPECIFICATIONS	
CHANNEL COUNT	80 SPST / 40 DPST
RELAY TYPE	Electromechanical, fail-safe
MAXIMUM SWITCHING VOLTAGE	300 V dc, 300 V ac
MAXIMUM SWITCHING CURRENT	2 A
MAXIMUM SWITCHING POWER	60 W dc, 62.5 VA
<i>*Maximum switched power is at 30 V/ 2 A dc. Max switched power is derated non-linearly as voltage is increased.</i>	
RATED SWITCH OPERATIONS	
Mechanical	1 x 10 ⁸ (no load)
Electrical	Min. 1 x 10 ⁵ @ (resistive load, 250VAC/0.25A), (resistive load, 30VDC/2A)
SWITCHING TIME	< 8 ms
PATH RESISTANCE	< 400 mΩ
INSULATION RESISTANCE	> 1 x 10 ⁹ Ω
MAXIMUM THERMAL OFFSET PER CHANNEL (HI-LO)	< 10 μV
CAPACITANCE	
Open channel	< 34 pF
Channel-mainframe	< 40 pF
High-low	< 18 pF
BANDWIDTH (-3 dB)	64 MHz (typical), 81 MHz (best), 52 MHz (worst),
CROSSTALK (TYPICAL)	
100 kHz	< -68 dB
1 MHz	< -50 dB
ISOLATION (TYPICAL)	
100 kHz	< -63 dB
1 MHz	< -44 dB
INSERTION LOSS (TYPICAL)	
100 kHz	< 0.06 dB
1 MHz	< 0.1 dB
10MHz	< 0.27 dB

FOR MATING CONNECTOR, CRIMP PINS, AND OTHER ACCESSORIES, PLEASE REFER TO *APPENDIX B*

SMX-5002 PLUG IN MODULE

50-CHANNEL FORM C (SPDT) SWITCH

The SMX-5002 switch module is a 50-channel, 2 A single-pole, double-throw general purpose relay switch. All relays are independently controllable. The 160-pin Front panel connector, connector Pin assignments, Schematic and Electrical specifications are given below. The appendix B has connector Accessory information for this module.

The SMX-5002 high-density basic switch module is designed for general purpose switching where individual relays can be used to route signals to and from the UUT or combined externally to form user-defined configurations. The latter approach allows the same switch module to be used for testing multiple UUTs by simply changing the configuration within a UUT-specific external adapter.

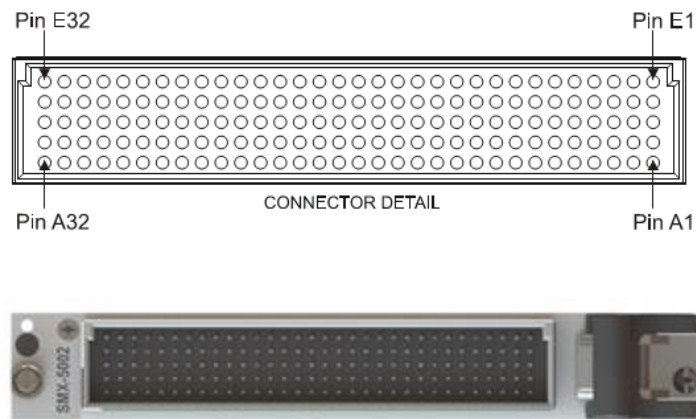

FIGURE 3-87: SMX-5002 CONNECTOR PIN LOCATIONS



FIGURE 3-88: SMX-5002 CARD VIEW

ROW A	SIGNAL	ROW B	SIGNAL	ROW C	SIGNAL	ROW D	SIGNAL	ROW E	SIGNAL
1	CH1-COM	1	CH2-COM	1	CH3-COM	1	CH4-COM	1	CH5-COM
2	CH1-NO	2	CH2-NO	2	CH3-NO	2	CH4-NO	2	CH5-NO
3	CH1-NC	3	CH2-NC	3	CH3-NC	3	CH4-NC	3	CH5-NC
4	CH6-COM	4	CH7-COM	4	CH8-COM	4	CH9-COM	4	CH10-COM
5	CH6-NO	5	CH7-NO	5	CH8-NO	5	CH9-NO	5	CH10-NO
6	CH6-NC	6	CH7-NC	6	CH8-NC	6	CH9-NC	6	CH10-NC
7	CH11-COM	7	CH12-COM	7	CH13-COM	7	CH14-COM	7	CH15-COM
8	CH11-NO	8	CH12-NO	8	CH13-NO	8	CH14-NO	8	CH15-NO
9	CH11-NC	9	CH12-NC	9	CH13-NC	9	CH14-NC	9	CH15-NC
10	CH16-COM	10	CH17-COM	10	CH18-COM	10	CH19-COM	10	CH20-COM
11	CH16-NO	11	CH17-NO	11	CH18-NO	11	CH19-NO	11	CH20-NO
12	CH16-NC	12	CH17-NC	12	CH18-NC	12	CH19-NC	12	CH20-NC
13	CH21-COM	13	CH22-COM	13	CH23-COM	13	CH24-COM	13	CH25-COM
14	CH21-NO	14	CH22-NO	14	CH23-NO	14	CH24-NO	14	CH25-NO
15	CH21-NC	15	CH22-NC	15	CH23-NC	15	CH24-NC	15	CH25-NC
16	CH26-COM	16	CH27-COM	16	CH28-COM	16	CH29-COM	16	CH30-COM
17	CH26-NO	17	CH27-NO	17	CH28-NO	17	CH29-NO	17	CH30-NO
18	CH26-NC	18	CH27-NC	18	CH28-NC	18	CH29-NC	18	CH30-NC
19	CH31-COM	19	CH32-COM	19	CH33-COM	19	CH34-COM	19	CH35-COM
20	CH31-NO	20	CH32-NO	20	CH33-NO	20	CH34-NO	20	CH35-NO
21	CH31-NC	21	CH32-NC	21	CH33-NC	21	CH34-NC	21	CH35-NC
22	CH36-COM	22	CH37-COM	22	CH38-COM	22	CH39-COM	22	CH40-COM
23	CH36-NO	23	CH37-NO	23	CH38-NO	23	CH39-NO	23	CH40-NO
24	CH36-NC	24	CH37-NC	24	CH38-NC	24	CH39-NC	24	CH40-NC
25	CH41-COM	25	CH42-COM	25	CH43-COM	25	CH44-COM	25	CH45-COM
26	CH41-NO	26	CH42-NO	26	CH43-NO	26	CH44-NO	26	CH45-NO
27	CH41-NC	27	CH42-NC	27	CH43-NC	27	CH44-NC	27	CH45-NC
28	CH46-COM	28	CH47-COM	28	CH48-COM	28	CH49-COM	28	CH50-COM
29	CH46-NO	29	CH47-NO	29	CH48-NO	29	CH49-NO	29	CH50-NO
30	CH46-NC	30	CH47-NC	30	CH48-NC	30	CH49-NC	30	CH50-NC
31	SHIELD	31	SHIELD	31	SHIELD	31	SHIELD	31	FP-OPEN
32	SHIELD	32	SHIELD	32	SHIELD	32	SHIELD	32	FP-GND

TABLE 3-37: SMX-5002 PIN/SIGNAL ASSIGNMENT

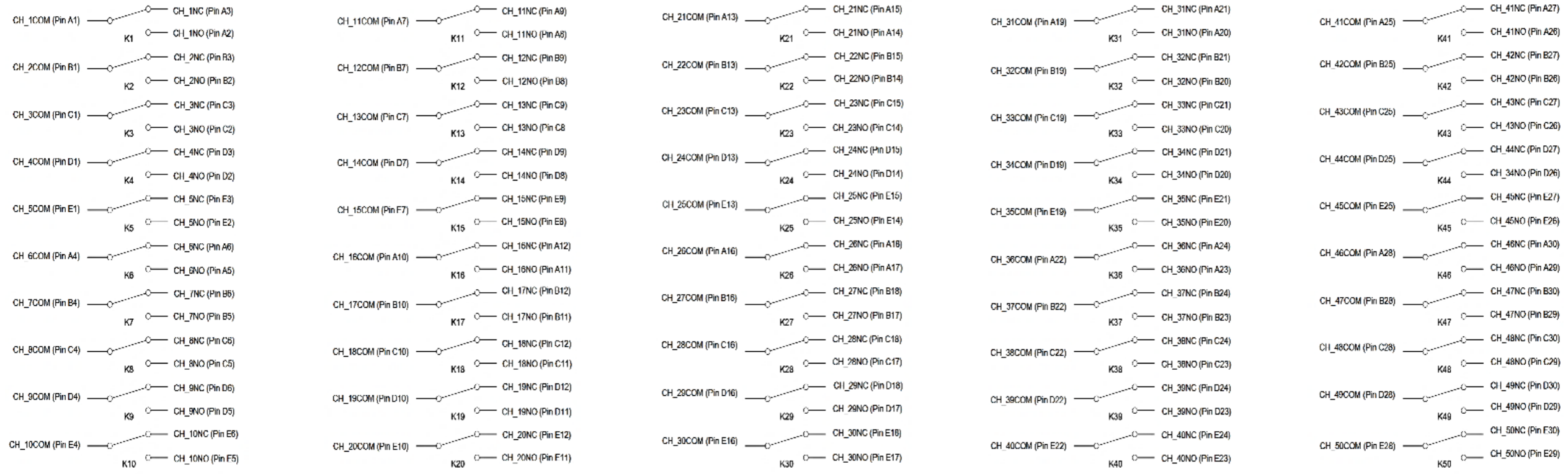

FIGURE 3-89: SMX-5002 SCHEMATIC VIEW

SMX-5002 SPECIFICATIONS

GENERAL SPECIFICATIONS	
CHANNEL COUNT	50 SPDT
RELAY TYPE	Electromechanical, fail-safe
MAXIMUM SWITCHING VOLTAGE	300 V dc, 300 V ac
MAXIMUM SWITCHING CURRENT	2 A
MAXIMUM SWITCHING POWER	60 W , 125 VA
RATED SWITCH OPERATIONS	
Mechanical	1 x 10 ⁷ (no load)
Electrical	1 x 10 ⁶ @ (resistive load, 50VDC, 0.1A), (resistive load, 10VDC, 10mA) @ 85 DegC, 2Hz
SWITCHING TIME	< 8 ms
PATH RESISTANCE	< 400 mΩ
INSULATION RESISTANCE	> 1 x 10 ⁹ Ω at 500VDC
MAXIMUM THERMAL OFFSET PER CHANNEL (HI-LO)	< 10 μV
CAPACITANCE	
Open channel	< 40 pF
Channel-mainframe	< 121 pF
High-low	< 45 pF
BANDWIDTH (-3 dB)	51 MHz (typical), 61 MHz (best), 39 MHz (worst),
CROSSTALK (TYPICAL)	
100 kHz	< -67 dB
1 MHz	< -54 dB
ISOLATION (TYPICAL)	
100 kHz	< -77 dB
1 MHz	< -53 dB
INSERTION LOSS (TYPICAL)	
100 kHz	< 0.18 dB
1 MHz	< 0.21 dB
10MHz	< 0.62 dB

FOR MATING CONNECTOR, CRIMP PINS, AND OTHER ACCESSORIES, PLEASE REFER TO *APPENDIX B*

SMX-5004 PLUG IN MODULE

30-CHANNEL FORM C (SPDT) SWITCH

The SMX-5004 switch module is a 30-channel, 5A single-pole, double-throw general purpose relay switch. All relays are independently controllable. The Front panel connector, connector Pin assignments, Schematic and Electrical specifications are given below.

The SMX-5004 high-density basic switch module is designed for general purpose switching where individual relays can be used to route signals to and from the UUT or combined externally to form user-defined configurations. The latter approach allows the same switch module to be used for testing multiple UUTs by simply changing the configuration within a UUT-specific external adapter.

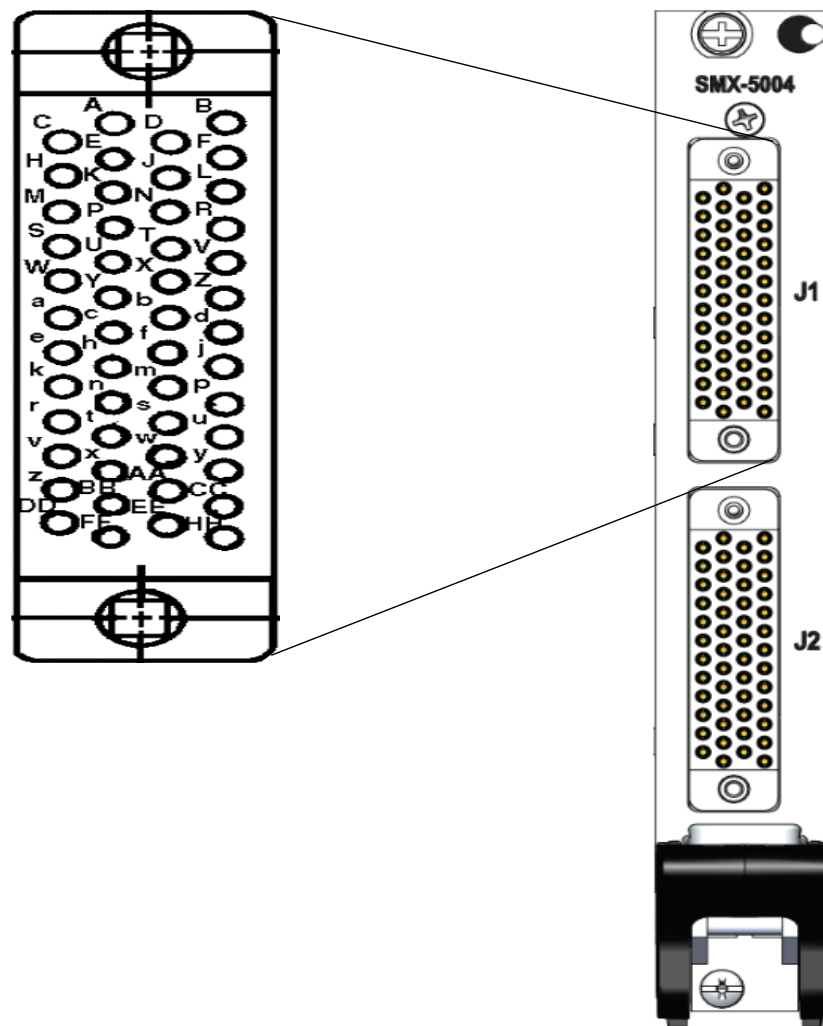

FIGURE 3-89A: SMX-5004 CONNECTOR PIN LOCATIONS

J1				J2			
Pin	Signal	Pin	Signal	Pin	Signal	Pin	Signal
A	CH1_COM	c	CH9_COM	A	CH16_COM	c	CH24_COM
B	CH1_NO	d	CH9_NO	B	CH16_NO	d	CH24_NO
C	CH1_NC	e	CH9_NC	C	CH16_NC	e	CH24_NC
D	CH2_COM	f	CH10_COM	D	CH17_COM	f	CH25_COM
E	CH2_NO	h	CH10_NO	E	CH17_NO	h	CH25_NO
F	CH2_NC	j	CH10_NC	F	CH17_NC	j	CH25_NC
H	CH3_COM	k	CH11_COM	H	CH18_COM	k	CH26_COM
J	CH3_NO	m	CH11_NO	J	CH18_NO	m	CH26_NO
K	CH3_NC	n	CH11_NC	K	CH18_NC	n	CH26_NC
L	CH4_COM	p	CH12_COM	L	CH19_COM	p	CH27_COM
M	CH4_NO	r	CH12_NO	M	CH19_NO	r	CH27_NO
N	CH4_NC	s	CH12_NC	N	CH19_NC	s	CH27_NC
P	CH5_COM	t	CH13_COM	P	CH20_COM	t	CH28_COM
R	CH5_NO	u	CH13_NO	R	CH20_NO	u	CH28_NO
S	CH5_NC	v	CH13_NC	S	CH20_NC	v	CH28_NC
T	CH6_COM	w	CH14_COM	T	CH21_COM	w	CH29_COM
U	CH6_NO	x	CH14_NO	U	CH21_NO	x	CH29_NO
V	CH6_NC	y	CH14_NC	V	CH21_NC	y	CH29_NC
W	CH7_COM	z	CH15_COM	W	CH22_COM	z	CH30_COM
X	CH7_NO	AA	CH15_NO	X	CH22_NO	AA	CH30_NO
Y	CH7_NC	BB	CH15_NC	Y	CH22_NC	BB	CH30_NC
Z	CH8_COM			Z	CH23_COM		
a	CH8_NO			a	CH23_NO		
b	CH8_NC			b	CH23_NC		

TABLE 3-38A: SMX-5004 PIN/SIGNAL ASSIGNMENT

FIGURE 3-90B: SMX-5004 SCHEMATIC VIEW

SMX-5004 SPECIFICATIONS

General Specifications	
Channel Count	30 SPDT
Relay Type	Electromechanical, fail-safe
Maximum Switching Voltage (Refer Graph shown below)	250 V AC, 125 V DC (0.2 A)
Maximum Switching Current (Refer Graph shown below)	5 A 250 V AC, 5 A 30 V DC
Maximum Switching Power	1,250 VA, 150 W
Minimum Contact Rating	-
-	10 mA, 5 V DC
Rated Switch Operations	
Mechanical	Min. 5×10^7 (at 180 times/min.)
Electrical	Min. 10^5 (resistive load)
Switching Time	< 10 ms
Path Resistance	< 0.15 Ω
Capacitance	
Open channel	< 0.1 nF
Channel-mainframe	< 0.3 nF
Bandwidth (-3 dB)	44 MHz (best), 38MHz (worst)
Crosstalk (Typical)	
100 kHz	< -61 dB
1 MHz	< -45 dB
Isolation (Typical)	
100 kHz	< -55 dB
1 MHz	< -40 dB
Insertion Loss (Typical)	
100 kHz	< 0.1 dB
1 MHz	< 0.1 dB
10MHz	< 0.72 dB

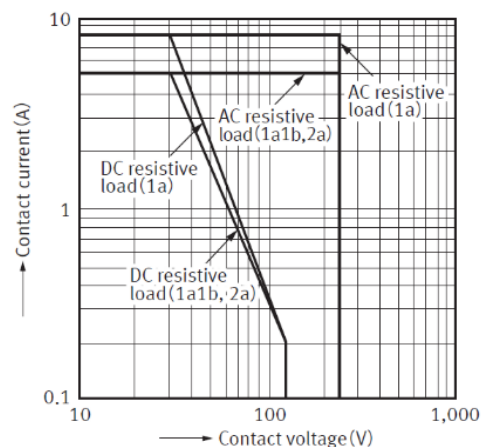

FIGURE 3-91C: SMX-5004 SWITCHING VOLTAGE AND CURRENT

SMX-61XX MODULE– RF MUX – 50 OHM

Below table shows the list of SMX-61xx series modules. These modules are designed with low frequency RF/uWave multiplexing switching capabilities. This series comes with excellent crosstalk and isolation parameters. These modules are also configured to avoid any unterminated stub effects, improving overall signal integrity and allowing for high frequency matrix designs and larger multiplexer configurations while maintaining bandwidth and VSWR.

Front panel connectivity is available in both SMB and PkZ formats to integrate seamlessly into new or existing test systems. Embedded virtual schematic control further simplifies setup and debugging allowing all relays to be engaged independent of application software and device drivers.

MODEL	DESCRIPTION
SMX-6101	(10) 1X4 COAX MUX, 3.8 GHz, 1-SLOT, 50-OHM, PkZ CONNECTOR
SMX-6101 SMB	(10) 1X4 COAX MUX, 3.4GHz, 2-SLOT, 50-OHM, SMB CONNECTORS
SMX-6103	(1) 1X32 COAX MUX, 1.6 GHz, 1-SLOT, 50-OHM, PkZ CONNECTOR
SMX-6103 SMB	(1) 1X32 COAX MUX, 1.5 GHz, 2-SLOT, 50-OHM, SMB CONNECTORS
SMX-6106	(2) 1X16 COAX MUX, 2 GHz, 1-SLOT, 50-OHM, PkZ CONNECTOR
SMX-6106 SMB	(2) 1X16 COAX MUX, 2.5 GHz, 2-SLOT, 50-OHM, SMB CONNECTORS
SMX-6105	(4) 1X8 COAX MUX, 2.5 GHz, 1-SLOT, 50-OHM, PkZ CONNECTOR
SMX-6105 SMB	(4) 1X8 COAX MUX, 2.7 GHz, 2-SLOT, 50-OHM, SMB CONNECTORS
SMX-6111	(5) 1X4 COAX MUX, 3.8 GHz, 1-SLOT, 50-OHM, PkZ CONNECTOR
SMX-6111 SMB	(5) 1X4 COAX MUX, 3.4 GHz, 2-SLOT, 50-OHM, SMB CONNECTORS
SMX-6116	(1) 1X16 COAX MUX, 2 GHz, 1-SLOT, 50-OHM, PkZ CONNECTOR
SMX-6116 SMB	(1) 1X16 COAX MUX, 2.5 GHz, 1-SLOT, 50-OHM, SMB CONNECTORS
SMX-6115	(2) 1X8 COAX MUX, 2.5 GHz, 1-SLOT, 50-OHM, PkZ CONNECTOR
SMX-6115 SMB	(2) 1X8 COAX MUX, 2.7 GHz, 1-SLOT, 50-OHM, SMB CONNECTORS
SMX-6144	(1) 4X4 COAX MATRIX, 2.0 GHz, 1-SLOT, 50-OHM, PkZ CONNECTOR
SMX-6144-SMB	(1) 4X4 COAX MATRIX, 2.0 GHz, 1-SLOT, 50-OHM, SMB CONNECTORS

TABLE 3-39: SMX-61XX MODEL SERIES

SMX-61XX GENERAL SPECIFICATIONS

GENERAL SPECIFICATIONS	
RELAY TYPE	Electromechanical, fail-safe
MAXIMUM SWITCHING VOLTAGE	300 VDC, 300VAC
MAXIMUM SWITCHING CURRENT	1.5 A
MAXIMUM SWITCHING POWER	50W (2.5GHz) 60 W, 62.5 VA
<i>*Maximum switched power is at 30 V/ 2 A dc. Max switched power is derated non-linearly as voltage is increased.</i>	
MAX. CONTINUOUS RF-POWER, 23°C	50W (2.5GHz)
RATED SWITCH OPERATIONS	
Mechanical	1 x 10 ⁷ (no load)
SWITCHING TIME	< 8 ms
PATH RESISTANCE	<500mΩ
CONNECTOR TYPE	SMB or PkZ

SMX-61XX (SMB) RF SPECIFICATIONS

	SMX-6101/6111 (1x4)	SMX-6105/6115 (1x8)	SMX-6106/6116 (1x16)	SMX-6103 (1x32)	SMX-6144 (4x4)
Characteristic Impedance	50 Ω	50 Ω	50 Ω	50 Ω	50 Ω
Bandwidth (-3 dB)	3.4 GHz	2.7 GHz	2.5 GHz	1.5 GHz	2.0 GHz
Insertion Loss @ 3.5 GHz	3.3 dB	4.4 dB	4.7 dB	5.5 dB	4.3 dB
Isolation & Crosstalk @ 1.5 GHz	60 dB	60 dB	60 dB	60 dB	60 dB
VSWR DC-3.5GHz	2:1	2:1	2:1	2:1	2:1
Propagation Delay (Typical)	2.35 ns	3.50 ns	3.50 ns	4.50 ns	3.50 ns

TABLE 3-40: SMX-6XXX MODEL SERIES RF SPECIFICATION (SMB CONNECTOR)

SMX-61XX (PkZ) RF SPECIFICATIONS

	SMX-6101/6111 (1x4)	SMX-6105/6115 (1x8)	SMX-6106/6116 (1x16)	SMX-6103 (1x32)	SMX-6144 (4x4)
Characteristic Impedance	50 Ω	50 Ω	50 Ω	50 Ω	50 Ω
Bandwidth (-3 dB)	3.8 GHz	2.5 GHz	2 GHz	1.6 GHz	2.0 GHz
Insertion Loss @ 3.5 GHz	2.5 dB	3.8 dB	4.5 dB	5.5 dB	4 dB
Isolation & Crosstalk @ 1.5 GHz	60 dB	60 dB	60 dB	60 dB	60 dB
VSWR DC-3.5GHz	1.6:1	2:1	2:1	2:1	1.8:1
Propagation Delay (Typical)	2.35 ns	3.50 ns	3.50 ns	4.50 ns	3.50 ns

TABLE 3-41: SMX-6XXX MODEL SERIES RF SPECIFICATION (PkZ CONNECTOR)

SMX-6101 MODULE – RF MUX – 50 OHM

(10) 1X4 COAXIAL MUX UP TO 3.8 GHz

The SMX-6101 module is designed with low frequency RF/uWave multiplexing switching capabilities. This high-density RF switch module is designed for high-fidelity RF switching applications up to 3.8 GHz. This design consists of ten 1x4 coaxial trees. It has excellent crosstalk and isolation is maintained by using RF relays along with short low-loss coaxial runs from the connector directly to the relays. This module is also configured to avoid any unterminated stub effects, improving overall signal integrity and allowing for high frequency matrix designs and larger multiplexer configurations while maintaining bandwidth and VSWR.

Front panel connectivity is available in both SMB and PkZ formats to integrate seamlessly into new or existing test systems. Embedded virtual schematic control further simplifies setup and debugging allowing all relays to be engaged independent of application software and device drivers. The SMX-6101 delivers unmatched bandwidth and isolation performance for multi-point connectivity, resulting in exceptional measurement integrity that is ideal for the most demanding aerospace, defense and automotive automated test equipment (ATE) applications.

NOTE SMX-61xx models without SMB in model name are SMX-61xx models with PkZ connector

SMX-6101 CONNECTOR PINS AND SIGNALS

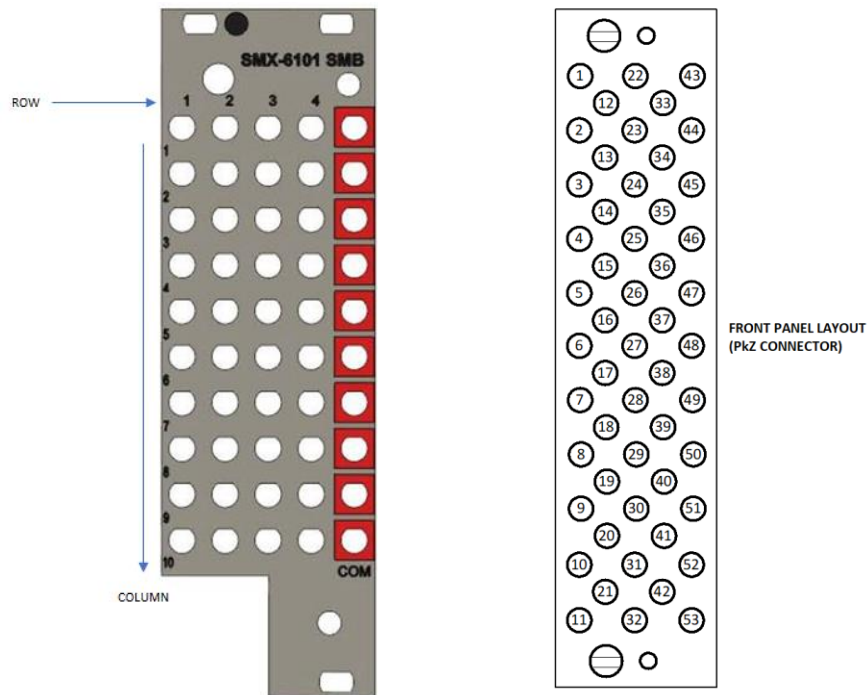

FIGURE 3-92: SMX-6101 FRONT PANEL LAYOUT (SMB CONNECTOR -LEFT IMAGE, PkZ CONNECTOR- RIGHT IMAGE)

***Note: Mapping '1' as CH1 hence 1NO1 refers to CH1_NO1 and COM1 refers to CH1_COM etc.**

PkZ Connector									
1	1NO2			22	1NO3			43	COM1
		12	1NO1	23	2NO3	33	1NC	44	COM2
2	2NO2								
		13	2NO1			34	2NC		
3	3NO2			24	3NO3			45	COM3
		14	3NO1			35	3NC		
4	4NO2			25	4NO3			46	COM4
		15	4NO1			36	4NC		
5	5NO2			26	5NO3			47	COM5
		16	5NO1			37	5NC		
6	6NO2			27	6NO3			48	COM6
		17	6NO1			38	6NC		
7	7NO2			28	7NO3			49	COM7
		18	7NO1			39	7NC		
8	8NO2			29	8NO3			50	COM8
		19	8NO1			40	8NC		
9	9NO2			30	9NO3			51	COM9
		20	9NO1			41	9NC		
10	10NO2			31	10NO3			52	COM10
		21	10NO1			42	10NC		
11				32				53	

TABLE 3-42: SMX-6101 PkZ CONNECTOR PINS & SIGNAL ASSIGNMENTS

	1	2	3	4	COM
1	11	12	13	14	COM1
2	21	22	23	24	COM2
3	31	32	33	34	COM3
4	41	42	43	44	COM4
5	51	52	53	54	COM5
6	61	62	63	64	COM6
7	71	72	73	74	COM7
8	81	82	83	84	COM8
9	91	92	93	94	COM9
10	101	102	103	104	COM10

SMB Connector			
1NC	11	6NC	61
1NO1	12	6NO1	62
1NO2	13	6NO2	63
1NO3	14	6NO3	64
COM1	15	COM6	65
2NC	21	7NC	71
2NO1	22	7NO1	72
2NO2	23	7NO2	73
2NO3	24	7NO3	74
COM2	25	COM7	75
3NC	31	8NC	81
3NO1	32	8NO1	82
3NO2	33	8NO2	83
3NO3	34	8NO3	84
COM3	35	COM8	85
4NC	41	9NC	91
4NO1	42	9NO1	92
4NO2	43	9NO2	93
4NO3	44	9NO3	94
COM4	45	COM9	95
5NC	51	10NC	101
5NO1	52	10NO1	102
5NO2	53	10NO2	103
5NO3	54	10NO3	104
COM5	55	COM10	105

TABLE 3-43: SMX-6101 SMB PIN MAPPING

NOTE In the above SMB PIN MAPPING table read the connector number as Row and then Column (ex., 11, 12, 21, 22...etc.)

SMX-6101 PkZ LOGICAL DIAGRAM

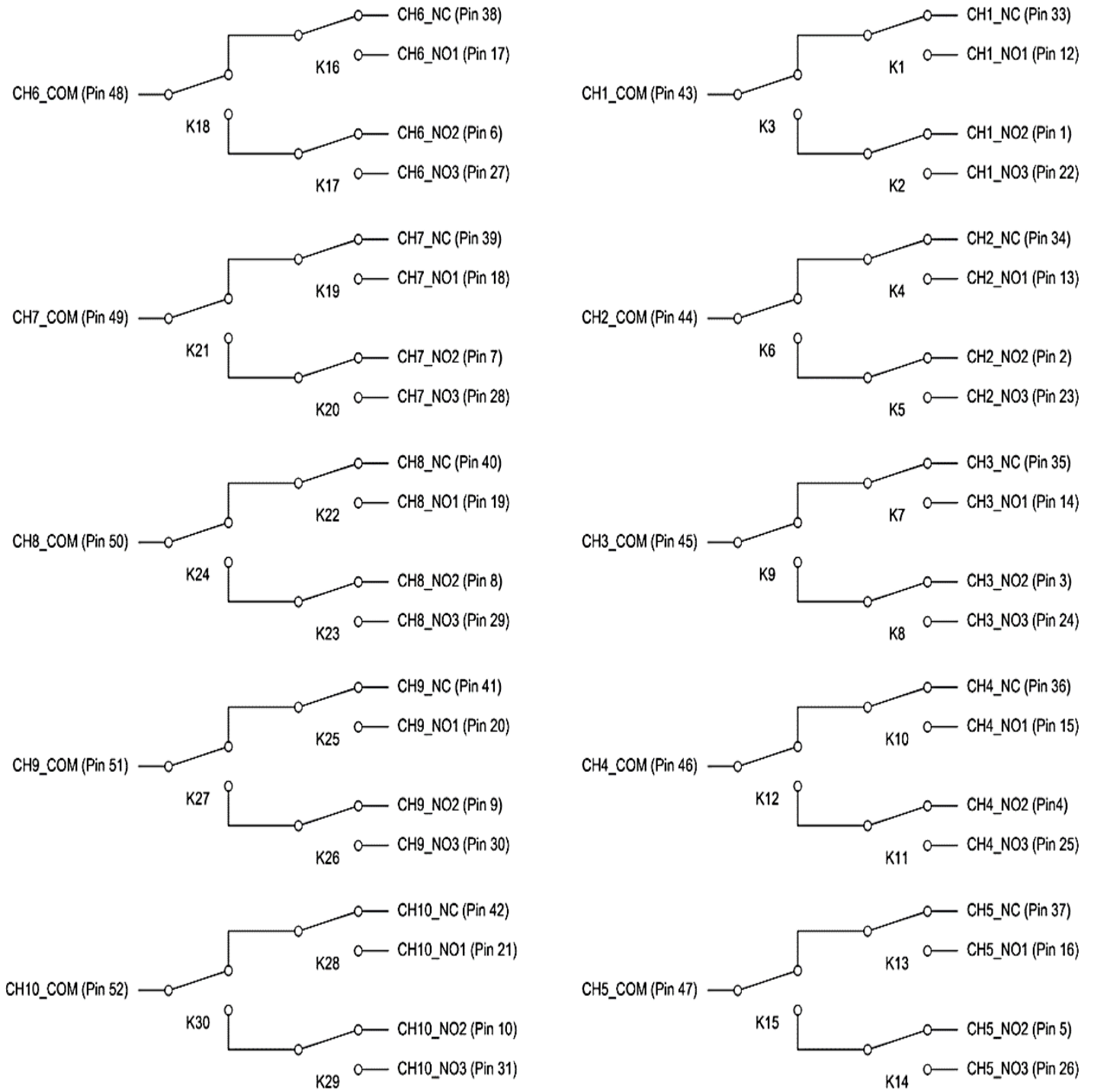

FIGURE 3-93: SMX-6101 PkZ LOGICAL DIAGRAM

SMX-6101 SMB LOGICAL DIAGRAM

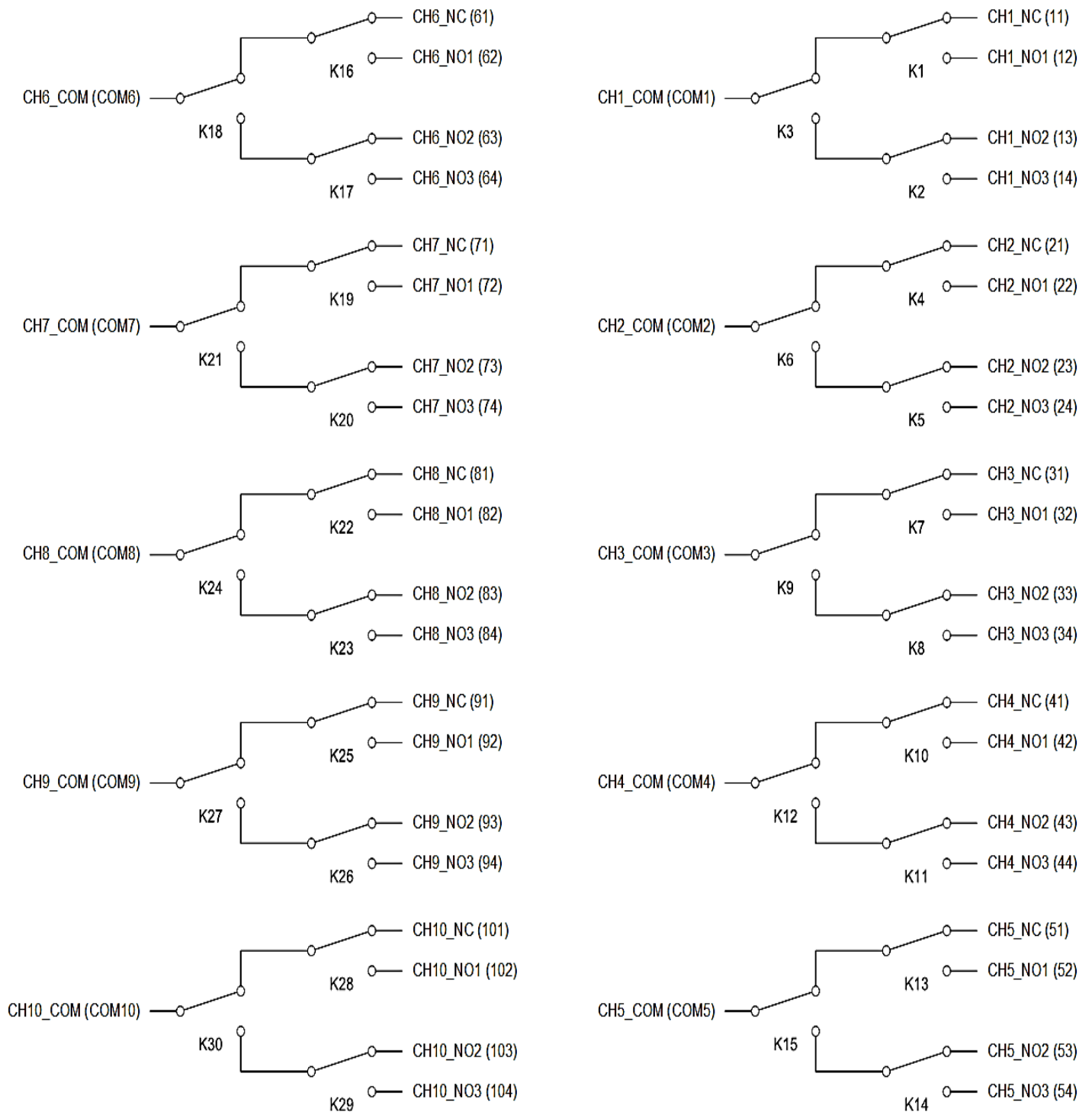

FIGURE 3-94: SMX-6101 SMB LOGICAL DIAGRAM

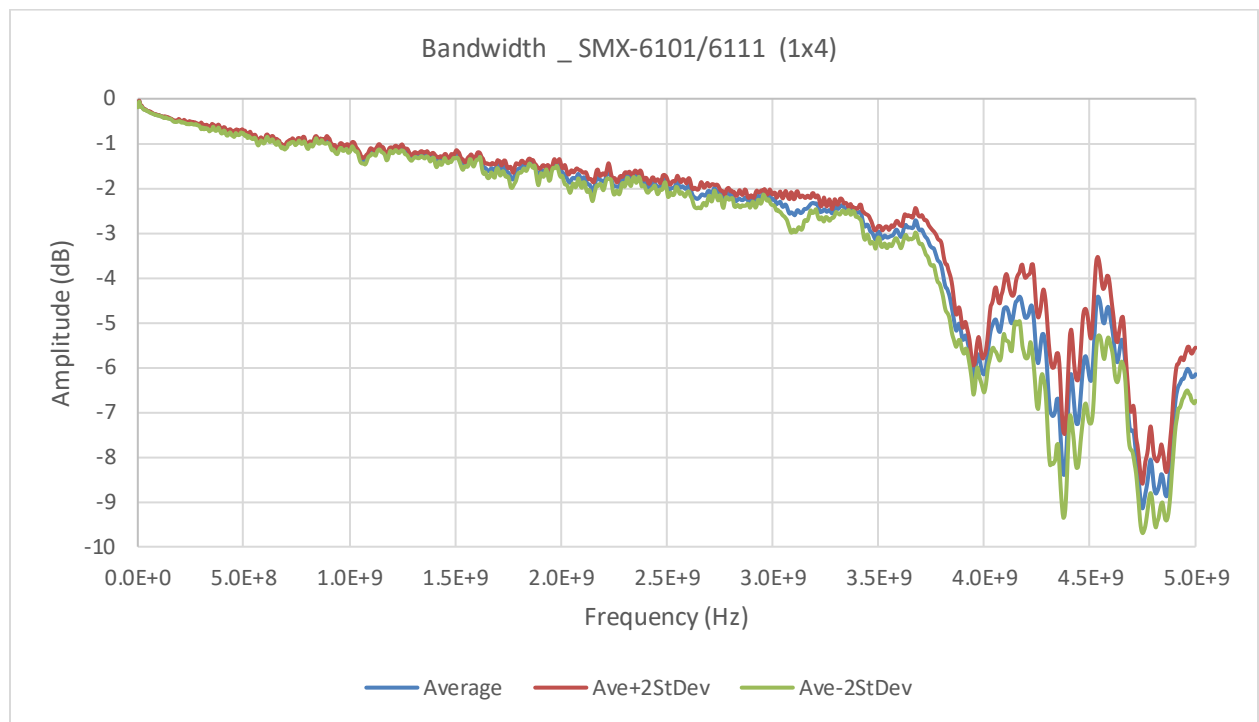

FIGURE 3-95: SMX-6101 SMB BANDWIDTH GRAPH

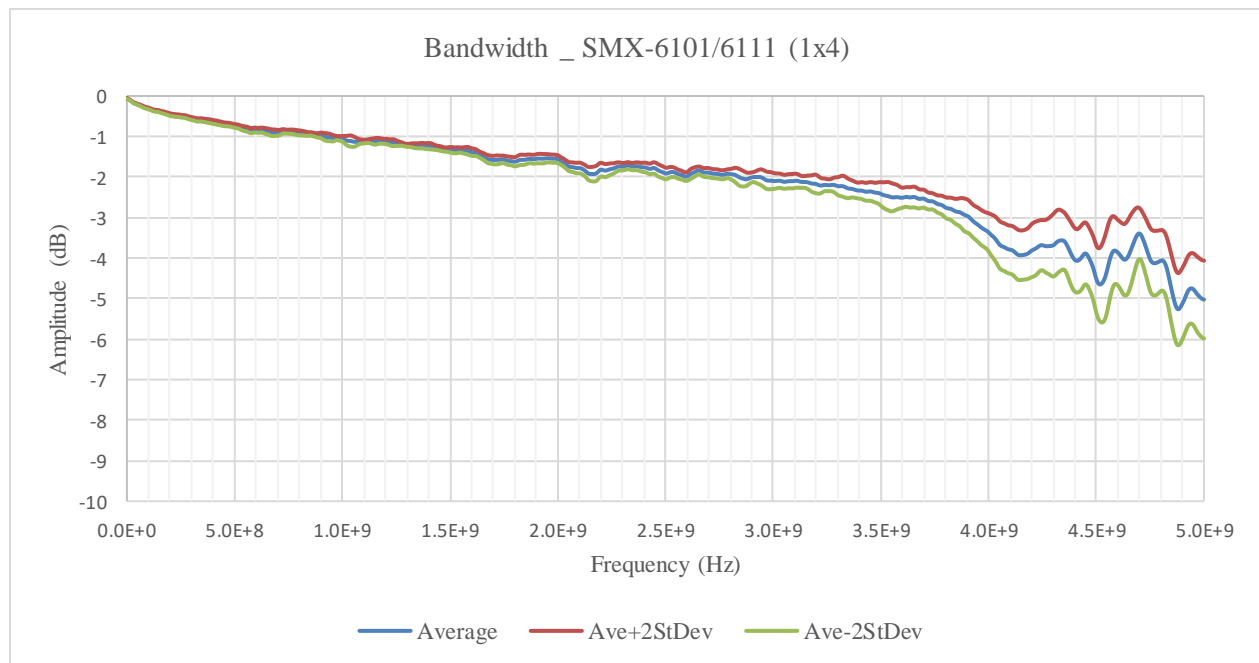

FIGURE 3-96: SMX-6101 PkZ BANDWIDTH GRAPH

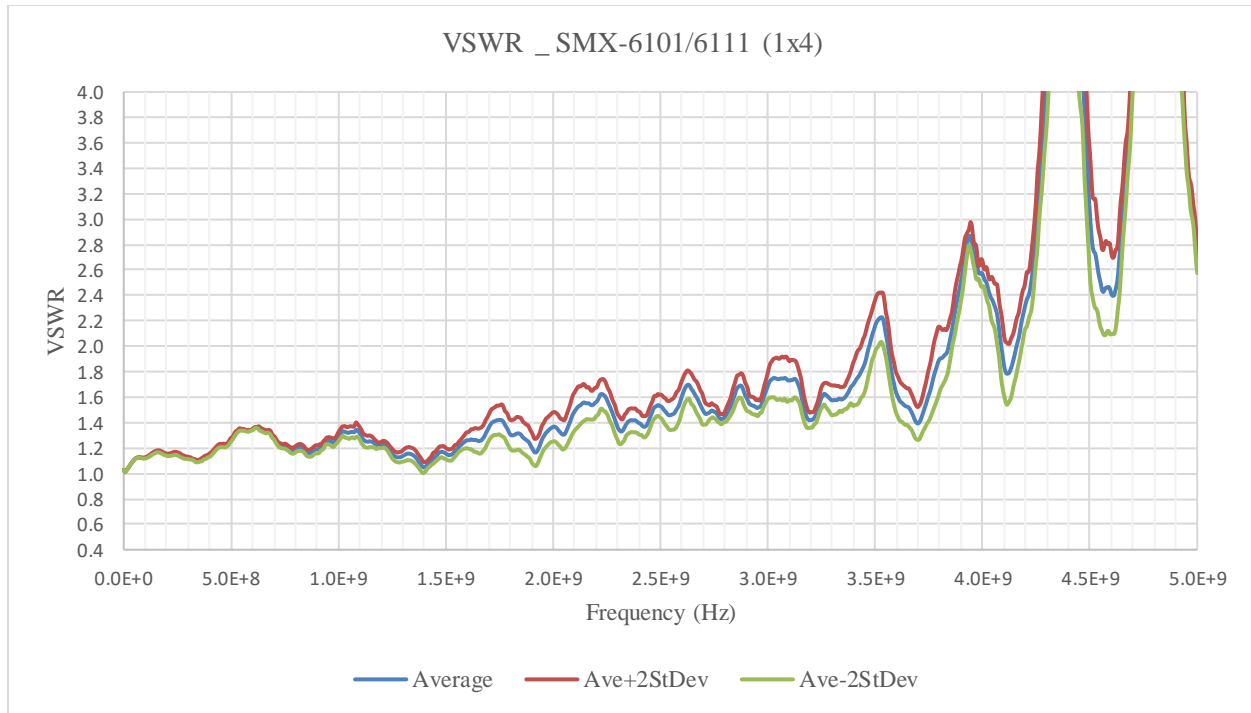

FIGURE 3-97: SMX-6101 SMB VSWR GRAPH

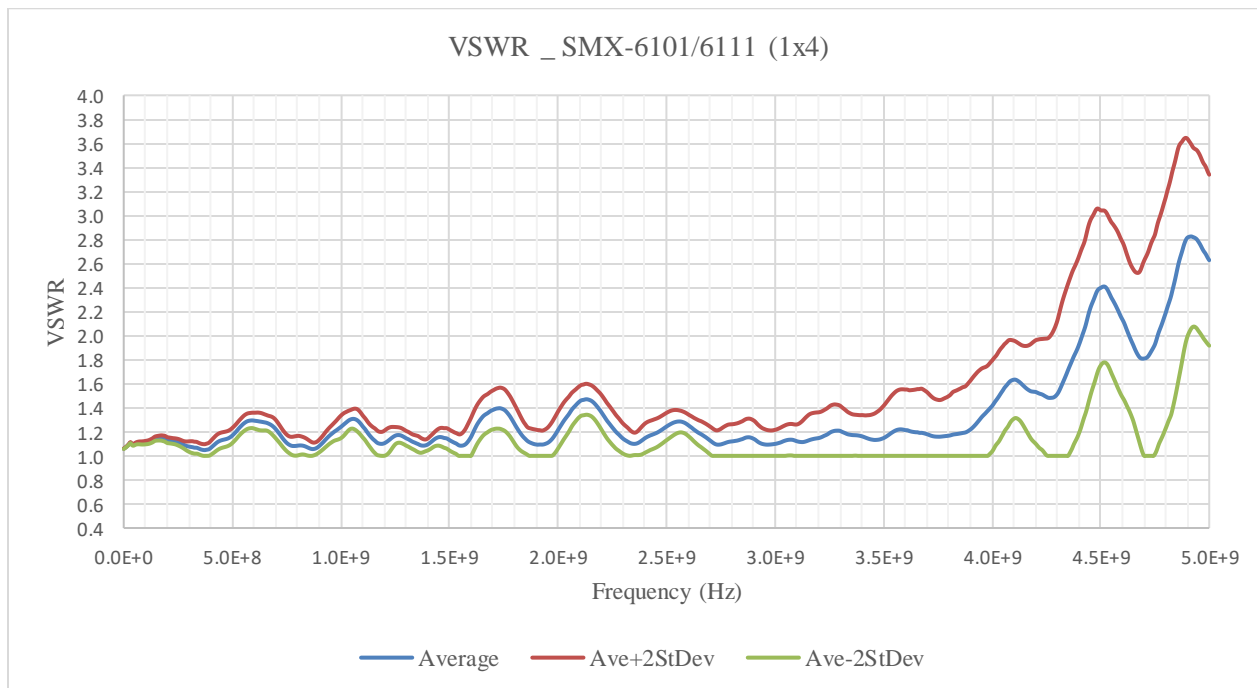

FIGURE 3-98: SMX-6101 PkZ VSWR GRAPH

SMX-6101 RF SPECIFICATIONS

	SMX-6101/6111 (1x4) SMB	SMX-6101/6111 (1x4) PkZ
Characteristic Impedance	50 Ω	50 Ω
Bandwidth (-3 dB)	3.4 GHz	3.8 GHz
Insertion Loss @ 3.5 GHz	≤ 3.3 dB	≤ 2.5 dB
Isolation & Crosstalk @ 1.5 GHz	≥ 60 dB	≥ 60 dB
VSWR DC-3.5GHz	2:1 max	1.6:1 max
Propagation Delay (Typical)	2.35 ns	2.35 ns

TABLE 3-44: SMX-6101 MODEL RF SPECIFICATIONS

SMX-6111 MODULE – RF MUX – 50 OHM

(5) 1X4 COAXIAL MUX UP TO 3.8 GHz

The SMX-6111 module is designed with low frequency RF/uWave multiplexing switching capabilities. This high-density RF switch module is designed for high-fidelity RF switching applications up to 3.8 GHz. It has excellent crosstalk and isolation is maintained by using RF relays along with short low-loss coaxial runs from the connector directly to the relays. This module is also configured to avoid any unterminated stub effects, improving overall signal integrity and allowing for high frequency matrix designs and larger multiplexer configurations while maintaining bandwidth and VSWR.

Front panel connectivity is available in both SMB and PkZ formats to integrate seamlessly into new or existing test systems. Embedded virtual schematic control further simplifies setup and debugging allowing all relays to be engaged independent of application software and device drivers. The SMX-6111 delivers unmatched bandwidth and isolation performance for multi-point connectivity, resulting in exceptional measurement integrity that is ideal for the most demanding aerospace, defense and automotive automated test equipment (ATE) applications.

NOTE SMX-61xx models without SMB in model name are SMX-61xx models with PkZ connector

SMX-6111 CONNECTOR PINS AND SIGNALS

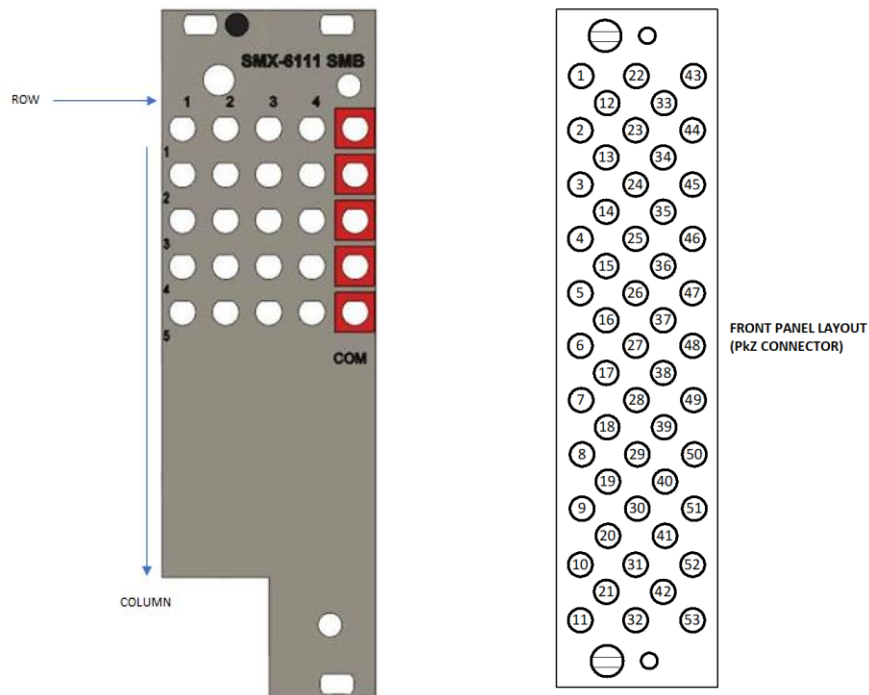

FIGURE 3-99: SMX-6111 FRONT PANEL LAYOUT(SMB CONNECTOR -LEFT IMAGE, PkZ CONNECTOR- RIGHT IMAGE)

**Note: Mapping '1' as CH1 hence 1NO1 refers to CH1_NO1 and COM1 refers to CH1_COM etc.*

PkZ Connector									
1	1NO2			22	1NO3			43	COM1
		12	1NO1			33	1NC		
2	2NO2			23	2NO3			44	COM2
		13	2NO1			34	2NC		
3	3NO2			24	3NO3			45	COM3
		14	3NO1			35	3NC		
4	4NO2			25	4NO3			46	COM4
		15	4NO1			36	4NC		
5	5NO2			26	5NO3			47	COM5
		16	5NO1			37	5NC		
6				27				48	
		17				38			
7				28				49	
		18				39			
8				29				50	
		19				40			
9				30				51	
		20				41			
10				31				52	
		21				42			
11				32				53	

TABLE 3-45: SMX-6111 PkZ CONNECTOR PINS & SIGNAL ASSIGNMENTS

	1	2	3	4	COM
1	11	12	13	14	COM1
2	21	22	23	24	COM2
3	31	32	33	34	COM3
4	41	42	43	44	COM4
5	51	52	53	54	COM5

SMB Connector	
1NC	11
1NO1	12
1NO2	13
1NO3	14
COM1	15
2NC	21
2NO1	22
2NO2	23
2NO3	24
COM2	25
3NC	31
3NO1	32
3NO2	33
3NO3	34
COM3	35
4NC	41
4NO1	42
4NO2	43
4NO3	44
COM4	45
5NC	51
5NO1	52
5NO2	53
5NO3	54
COM5	55

TABLE 3-46: SMX- 6111 SMB PIN MAPPING

NOTE In the above SMB PIN MAPPING table read the connector number as Row and then Column (ex., 11, 12, 21, 22...etc.)

SMX-6111 PkZ LOGICAL DIAGRAM

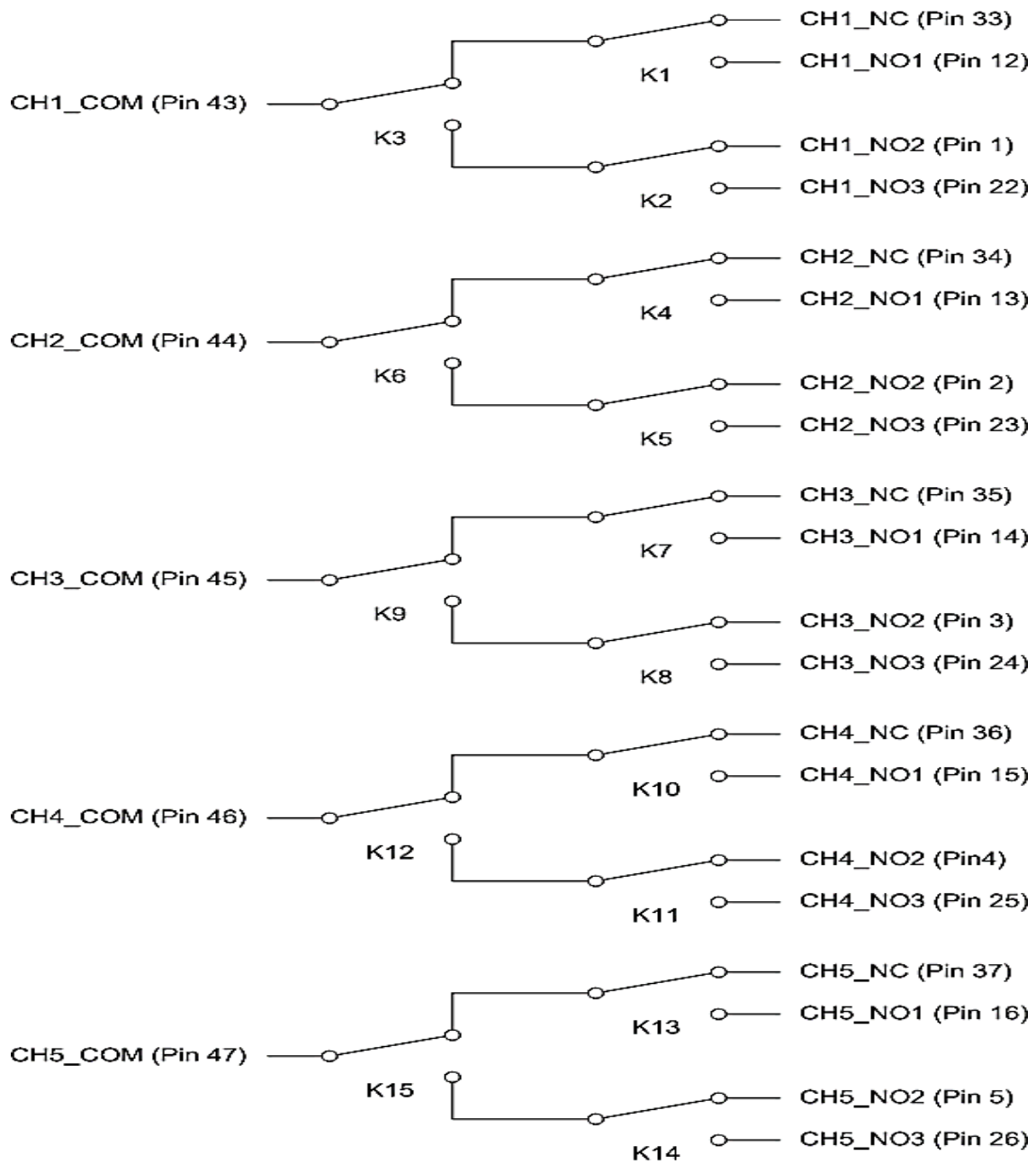

FIGURE 3-100: SMX-6111PkZ LOGICAL DIAGRAM

SMX-6111 SMB LOGICAL DIAGRAM

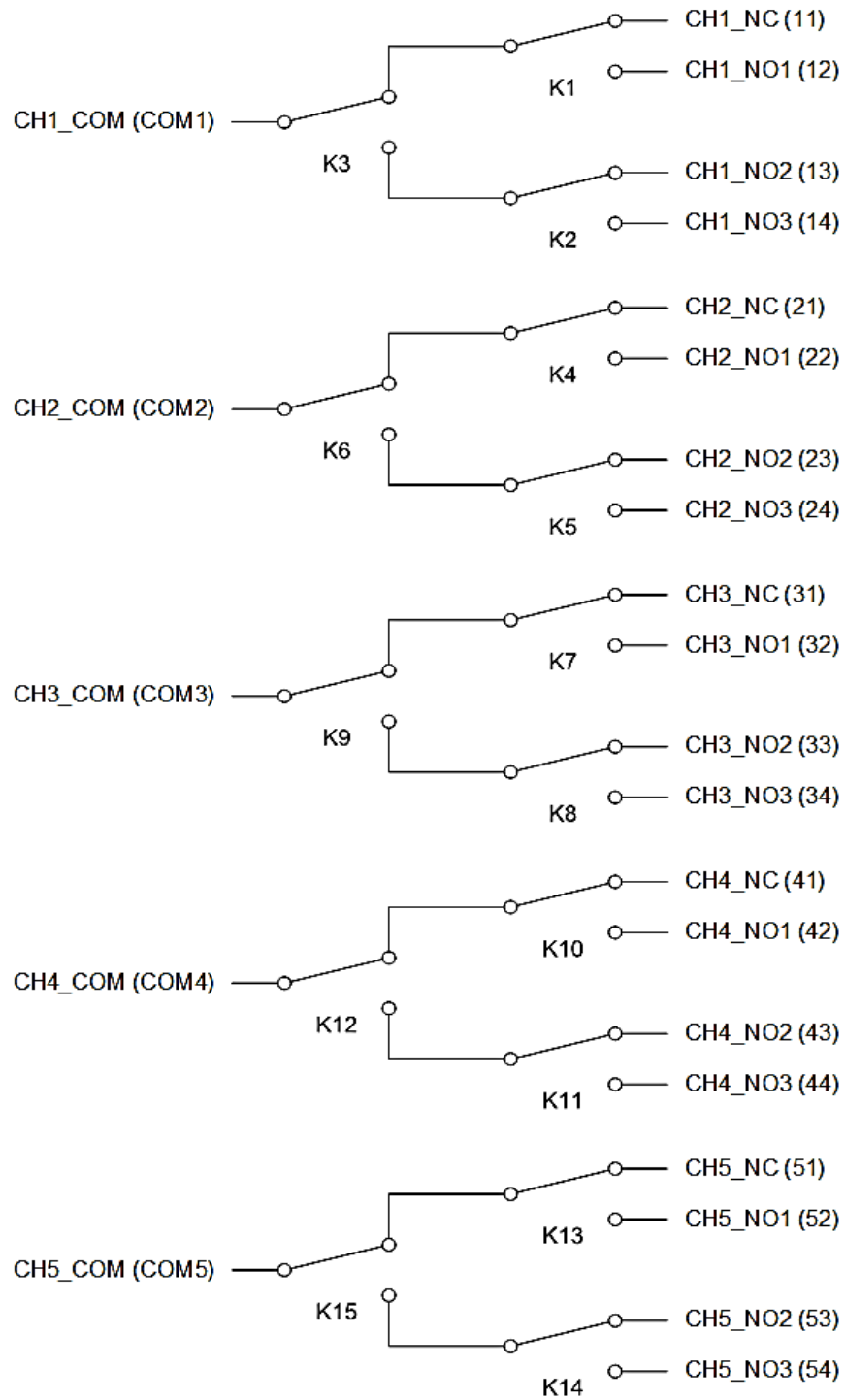

FIGURE 3-101: SMX-6111SMB LOGICAL DIAGRAM

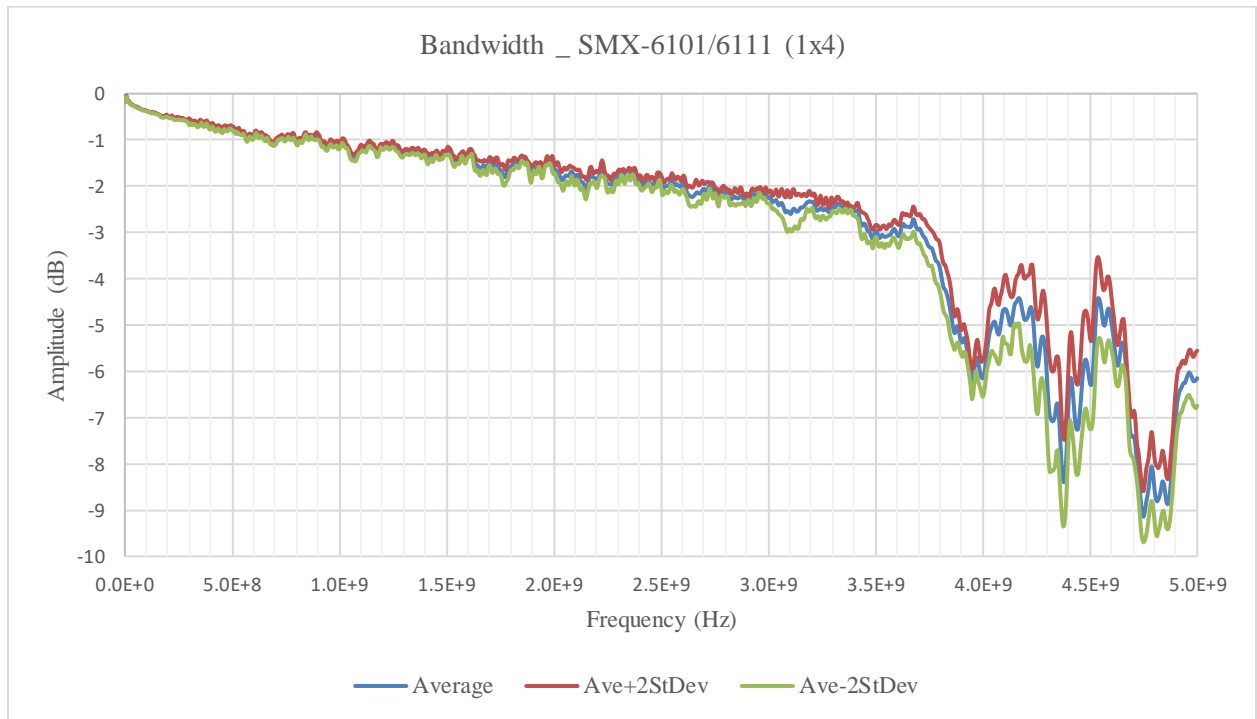

FIGURE 3-102: SMX-6111SMB BANDWIDTH GRAPH

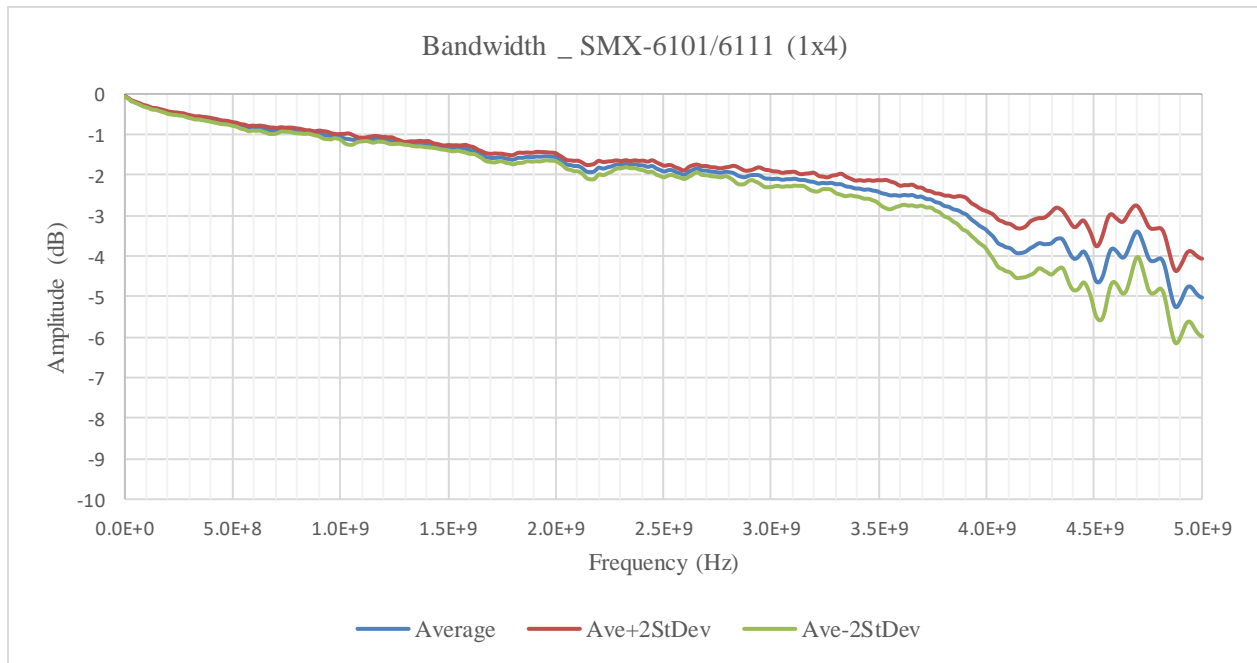

FIGURE 3-103: SMX-6111PKZ BANDWIDTH GRAPH

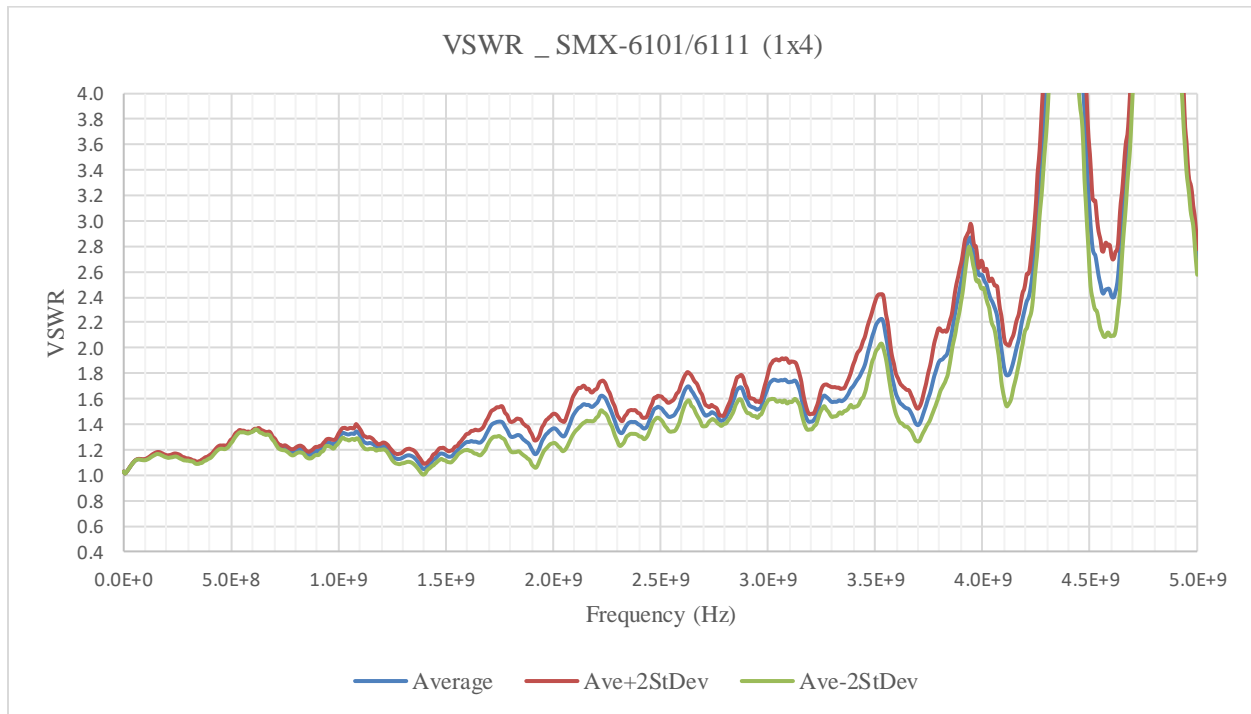

FIGURE 3-104: SMX-6111SMB VSWR GRAPH

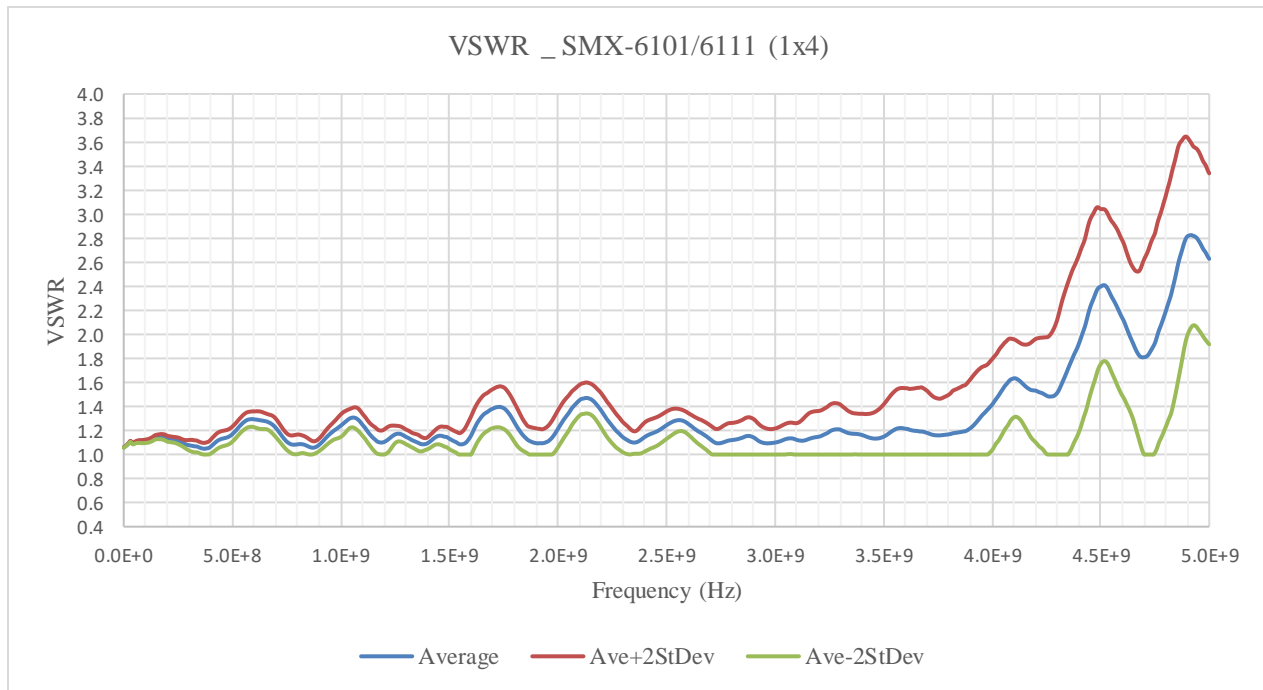

FIGURE 3-105: SMX-6111PKZ VSWR GRAPH

SMX-6111 RF SPECIFICATIONS

	SMX-6111/6101 (1x4) SMB	SMX-6111/6101 (1x4) PkZ
Characteristic Impedance	50 Ω	50 Ω
Bandwidth (-3 dB)	3.4 GHz	3.8 GHz
Insertion Loss @ 3.5 GHz	≤ 3.3 dB	≤ 2.5 dB
Isolation & Crosstalk @ 1.5 GHz	≥ 60 dB	≥ 60 dB
VSWR DC-3.5GHz	2:1 max	1.6:1 max
Propagation Delay (Typical)	2.35 ns	2.35 ns

TABLE 3-47: SMX-6111 MODEL RF SPECIFICATIONS

SMX-6106 MODULE – RF MUX – 50 OHM

(2) 1X16 COAXIAL MUX UP TO 2.5 GHz

The SMX-6106 module is designed with low frequency RF/uWave multiplexing switching capabilities. This high-density RF switch module is designed for high-fidelity RF switching applications up to 2.5 GHz. It has excellent crosstalk and isolation is maintained by using RF relays along with short low-loss coaxial runs from the connector directly to the relays. This module is also configured to avoid any unterminated stub effects, improving overall signal integrity and allowing for high frequency matrix designs and larger multiplexer configurations while maintaining bandwidth and VSWR.

Front panel connectivity is available in both SMB and PkZ formats to integrate seamlessly into new or existing test systems. Embedded virtual schematic control further simplifies setup and debugging allowing all relays to be engaged independent of application software and device drivers. The SMX-6106 delivers unmatched bandwidth and isolation performance for multi-point connectivity, resulting in exceptional measurement integrity that is ideal for the most demanding aerospace, defense and automotive automated test equipment (ATE) applications.

NOTE SMX-61xx models without SMB in model name are SMX-61xx models with PkZ connector

SMX-6106 CONNECTOR PINS AND SIGNALS

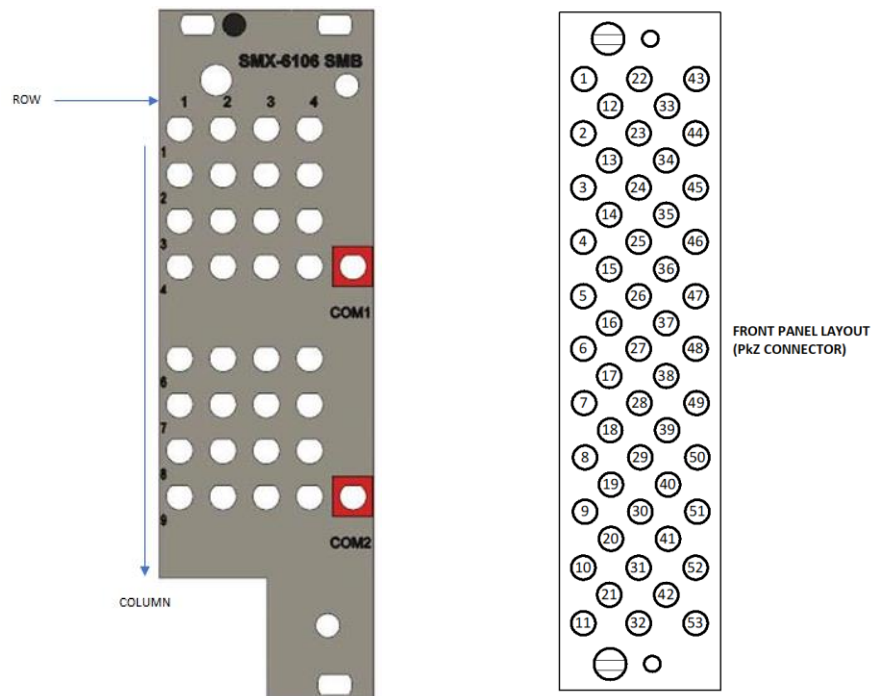

FIGURE 3-106: SMX-6106 FRONT PANEL LAYOUT (SMB CONNECTOR -LEFT IMAGE, PkZ CONNECTOR- RIGHT IMAGE)

***Note: Mapping '1' as CH1 hence 1NO1 refers to CH1_NO1 and COM1 refers to CH1_COM etc.**

PkZ Connector									
1	1NO2			22	1NO3			43	
		12	1NO1			33	1NC		
2	1NO6			23	1NO7			44	
		13	1NO5			34	1NO4		
3	1NO10			24	1NO11			45	
		14	1NO9			35	1NO8		
4	1NO14			25	1NO15			46	
		15	1NO13			36	1NO12		
5				26				47	COM1
		16				37			
6	2NO2			27	2NO3			48	
		17	2NO1			38	2NC		
7	2NO6			28	2NO7			49	
		18	2NO5			39	2NO4		
8	2NO10			29	2NO11			50	
		19	2NO9			40	2NO8		
9	2NO14			30	2NO15			51	
		20	2NO13			41	2NO12		
10				31				52	COM2
		21				42			
11				32				53	

TABLE 3-48: SMX-6106 PkZ CONNECTOR PINS & SIGNAL ASSIGNMENTS

	1	2	3	4	COM
1	11	12	13	14	COM1
2	21	22	23	24	
3	31	32	33	34	
4	41	42	43	44	
6	61	62	63	64	COM2
7	71	72	73	74	
8	81	82	83	84	
9	91	92	93	94	

SMB Connector			
1NC	11	2NC	61
1NO1	12	2NO1	62
1NO2	13	2NO2	63
1NO3	14	2NO3	64
1NO4	21	2NO4	71
1NO5	22	2NO5	72
1NO6	23	2NO6	73
1NO7	24	2NO7	74
1NO8	31	2NO8	81
1NO9	32	2NO9	82
1NO10	33	2NO10	83
1NO11	34	2NO11	84
1NO12	41	2NO12	91
1NO13	42	2NO13	92
1NO14	43	2NO14	93
1NO15	44	2NO15	94
COM1		COM2	

TABLE 3-49: SMX-6106 SMB PIN MAPPING

NOTE In the above SMB PIN MAPPING table read the connector number as Row and then Column (ex., 11, 12, 21, 22...etc.)

SMX-6106 PkZ LOGICAL DIAGRAM

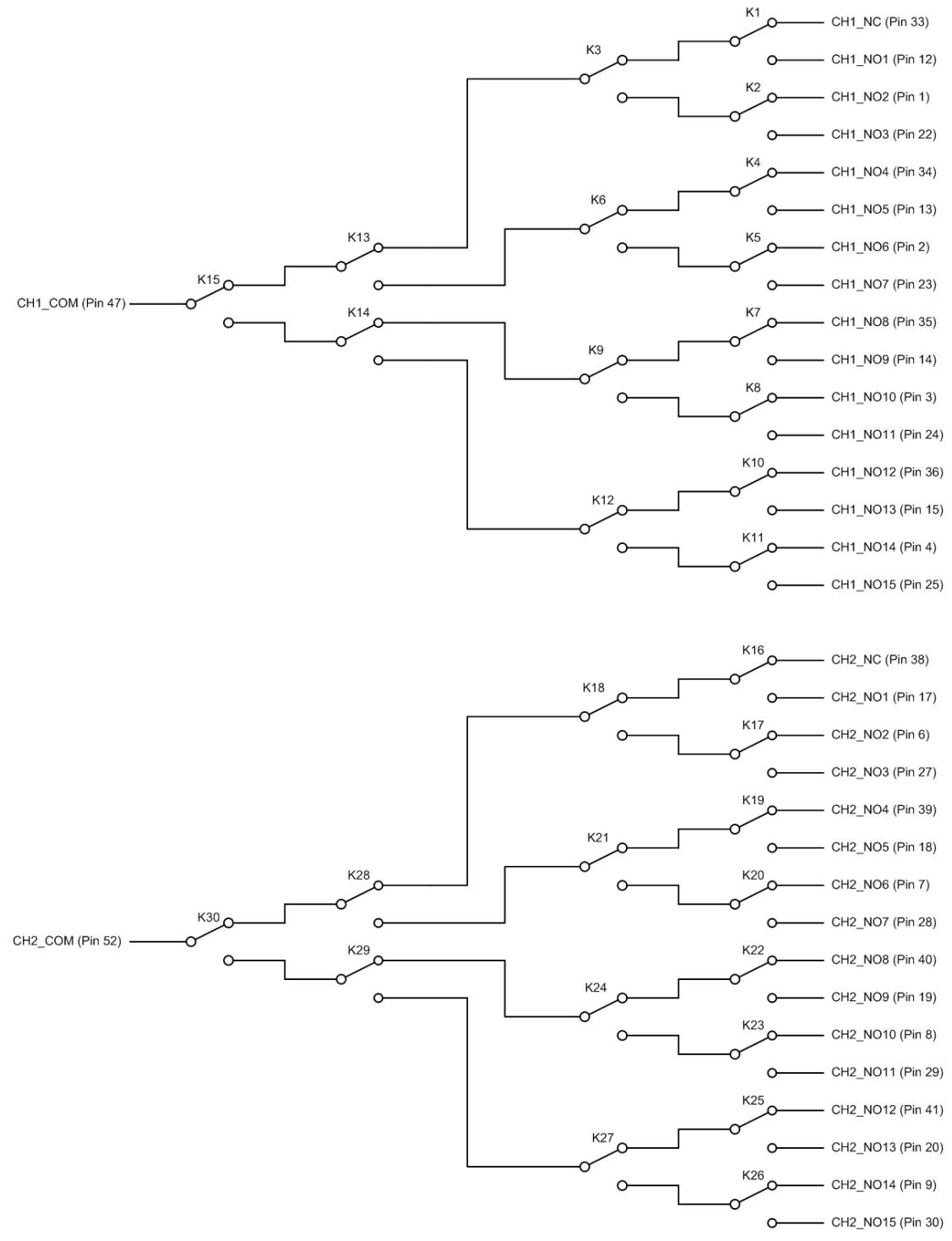

FIGURE 3-107: SMX-6106PkZ LOGICAL DIAGRAM

SMX-6106SMB LOGICAL DIAGRAM

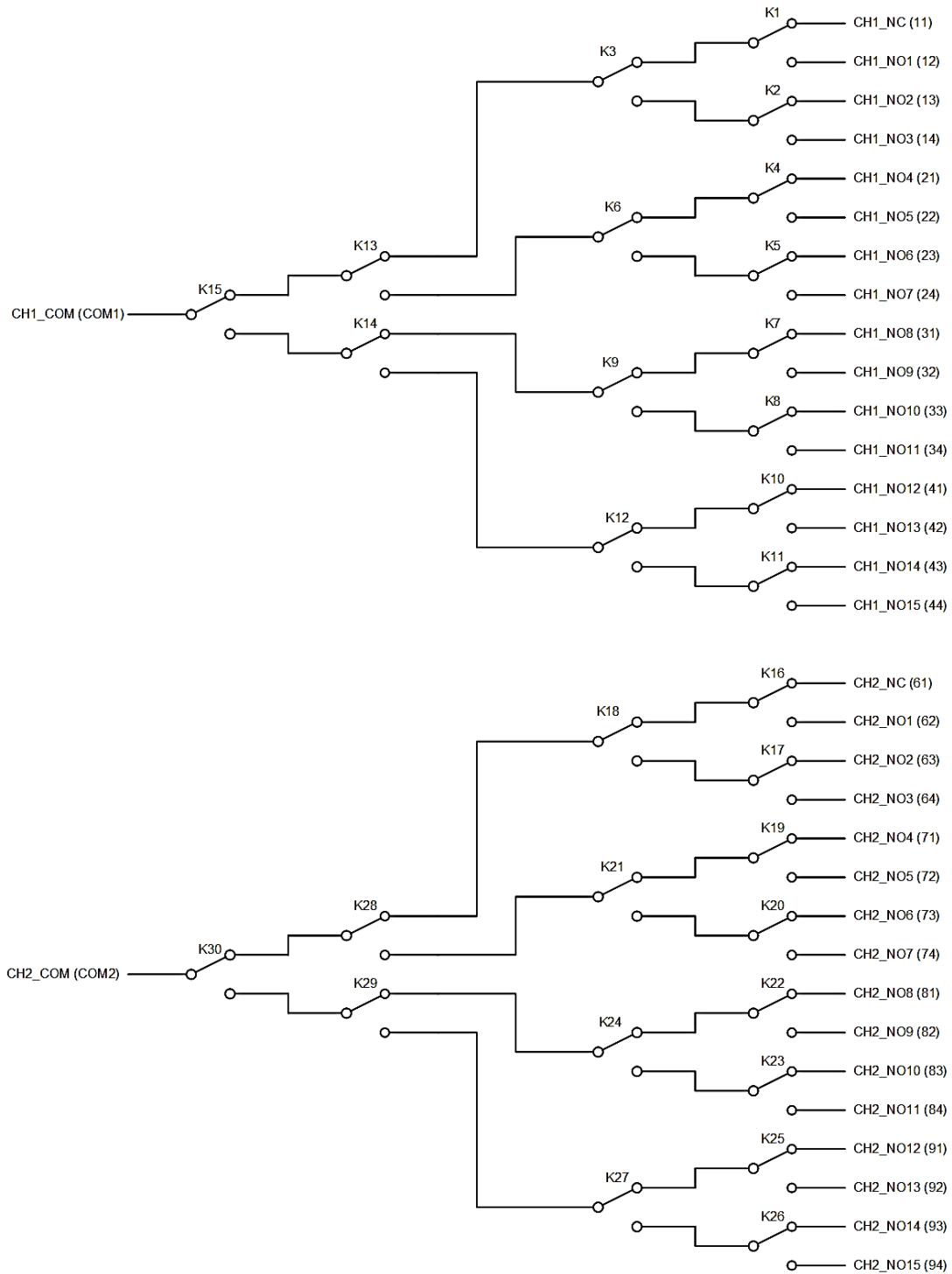

FIGURE 3-108: SMX-6106SMB LOGICAL DIAGRAM

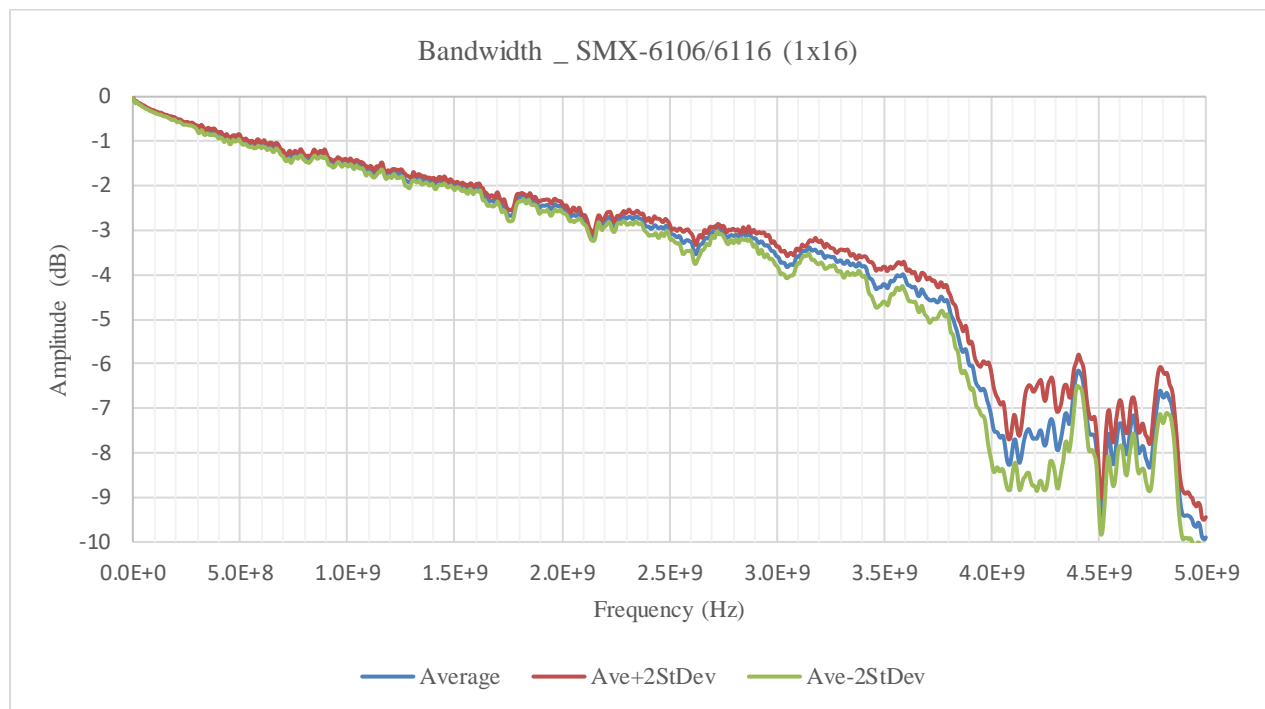

FIGURE 3-109: SMX-6106SMB BANDWIDTH GRAPH

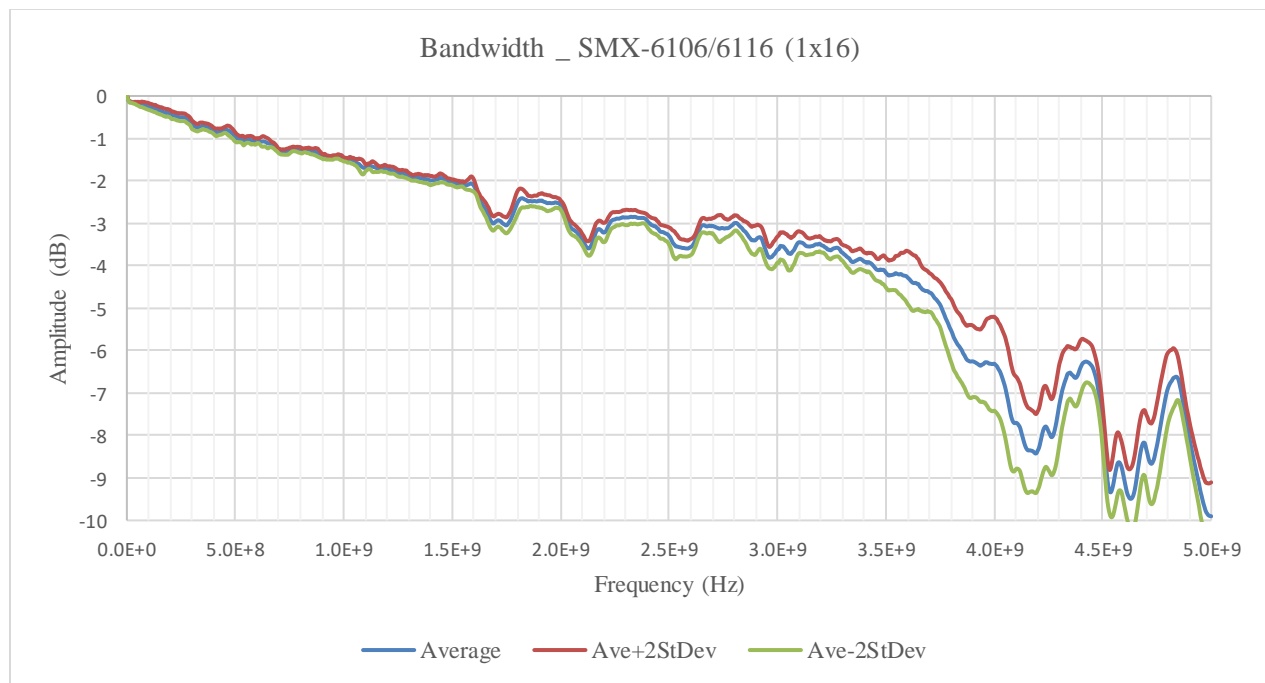

FIGURE 3-110: SMX-6106PkZ BANDWIDTH GRAPH

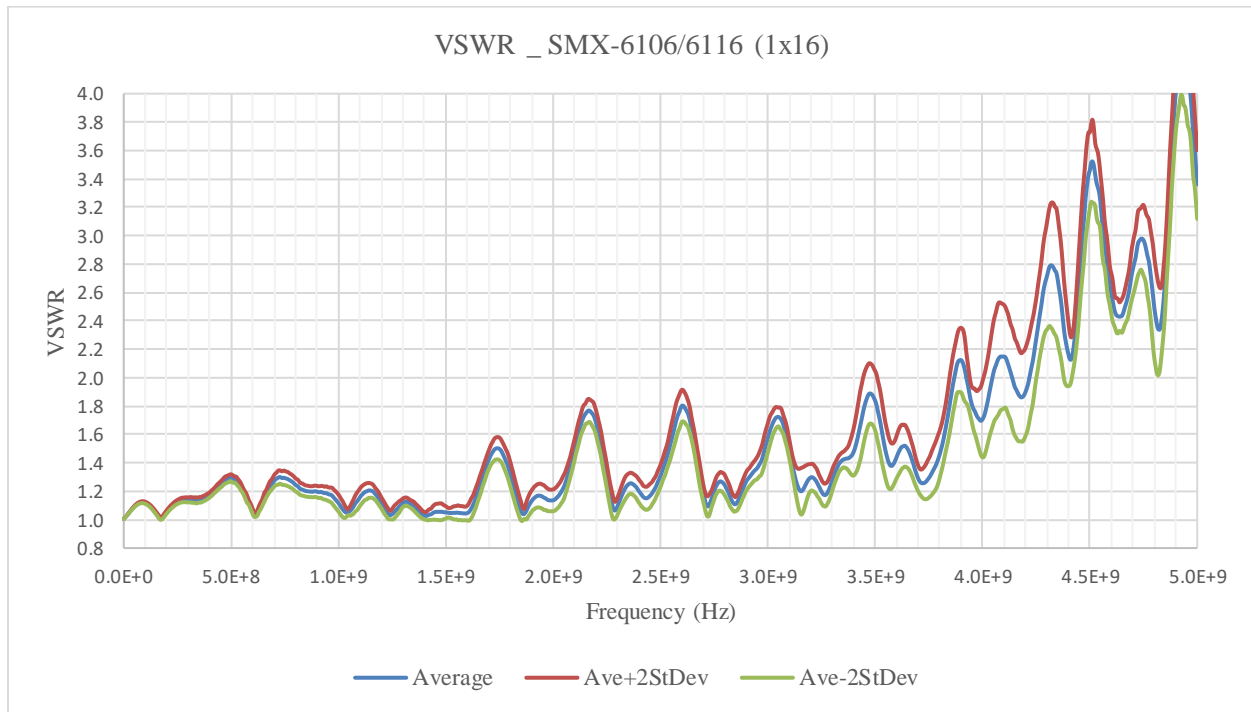

FIGURE 3-111: SMX-6106SMB AND PkZ VSWR GRAPH

SMX-6106 RF SPECIFICATIONS

	SMX-6106/6116 (1x16) SMB	SMX-6111/6101 (1x16) PkZ
Characteristic Impedance	50 Ω	50 Ω
Bandwidth (-3 dB)	2.5 GHz	2 GHz
Insertion Loss @ 3.5 GHz	≤ 4.7 dB	≤ 4.5 dB
Isolation & Crosstalk @ 1.5 GHz	≥ 60 dB	≥ 60 dB
VSWR DC-3.5GHz	2:1 max	2:1 max
Propagation Delay (Typical)	3.5 ns	3.5 ns

TABLE 3-50: SMX-6106 MODEL RF SPECIFICATIONS

SMX-6116 MODULE – RF MUX – 50 OHM

(1) 1X16 COAXIAL MUX UP TO 2.5 GHz

The SMX-6116 module is designed with low frequency RF/uWave multiplexing switching capabilities. This high-density RF switch module is designed for high-fidelity RF switching applications up to 2.5 GHz. It has excellent crosstalk and isolation is maintained by using RF relays along with short low-loss coaxial runs from the connector directly to the relays. This module is also configured to avoid any unterminated stub effects, improving overall signal integrity and allowing for high frequency matrix designs and larger multiplexer configurations while maintaining bandwidth and VSWR.

Front panel connectivity is available in both SMB and PkZ formats to integrate seamlessly into new or existing test systems. Embedded virtual schematic control further simplifies setup and debugging allowing all relays to be engaged independent of application software and device drivers. The SMX-6116 delivers unmatched bandwidth and isolation performance for multi-point connectivity, resulting in exceptional measurement integrity that is ideal for the most demanding aerospace, defense and automotive automated test equipment (ATE) applications.

NOTE SMX-61xx models without SMB in model name are SMX-61xx models with PkZ connector

SMX-6116 CONNECTOR PINS AND SIGNALS

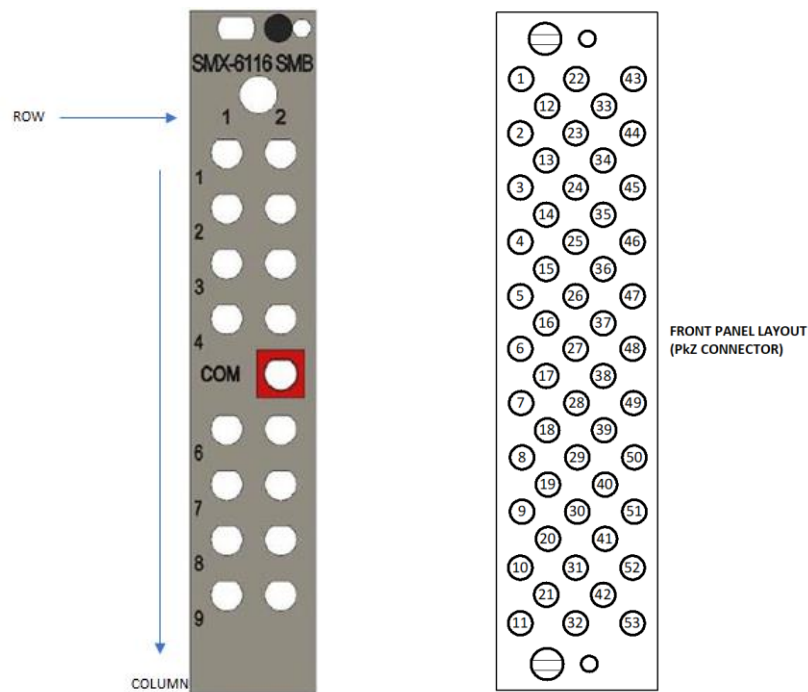

FIGURE 3-112: SMX-6116 FRONT PANEL LAYOUT (SMB CONNECTOR -LEFT IMAGE, PkZ CONNECTOR- RIGHT IMAGE)

**Note: Mapping '1' as CH1 hence 1NO1 refers to CH1_NO1 and COM1 refers to CH1_COM etc.*

PkZ Connector									
1	1NO2			22	1NO3			43	
		12	1NO1			33	1NC		
2	1NO6			23	1NO7			44	
		13	1NO5			34	1NO4		
3	1NO10			24	1NO11			45	
		14	1NO9			35	1NO8		
4	1NO14			25	1NO15			46	
		15	1NO13			36	1NO12		
5				26				47	COM1
		16				37			
6				27				48	
		17				38			
7				28				49	
		18				39			
8				29				50	
		19				40			
9				30				51	
		20				41			
10				31				52	
		21				42			
11				32				53	

TABLE 3-51: SMX-6116 PkZ CONNECTOR PINS & SIGNAL ASSIGNMENTS

	1	2	COM
1	11	12	COM
2	21	22	
3	31	32	
4	41	42	
6	61	62	
7	71	72	
8	81	82	
9	91	92	

SMB Connector	
1NC	11
1NO1	12
1NO2	21
1NO3	22
1NO4	31
1NO5	32
1NO6	41
1NO7	42
1NO8	61
1NO9	62
1NO10	71
1NO11	72
1NO12	81
1NO13	82
1NO14	91
1NO15	92
COM1	COM

TABLE 3-52: SMX- 6116 SMB PIN MAPPING

NOTE In the above SMB PIN MAPPING table read the connector number as Row and then Column (ex., 11, 12, 21, 22...etc.)

SMX-6116 PkZ LOGICAL DIAGRAM

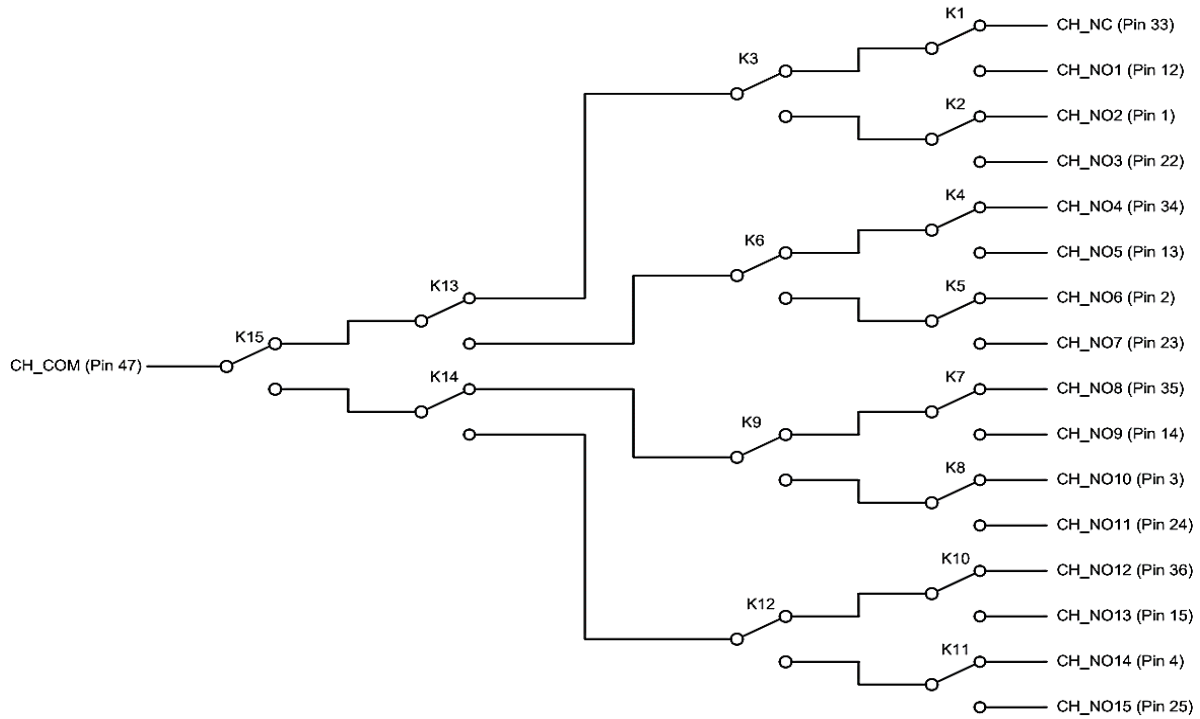

FIGURE 3-113: SMX-6116PkZ LOGICAL DIAGRAM

SMX-6116 SMB LOGICAL DIAGRAM

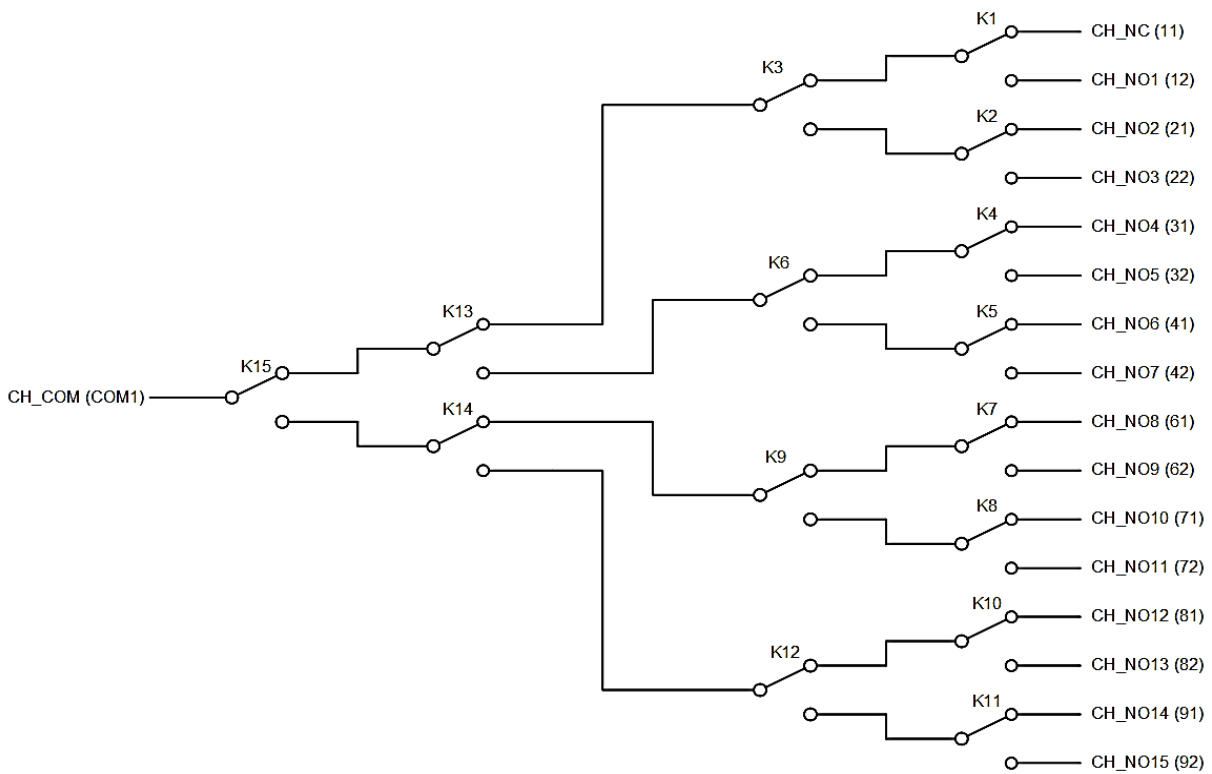

FIGURE 3-114: SMX-6116SMB LOGICAL DIAGRAM

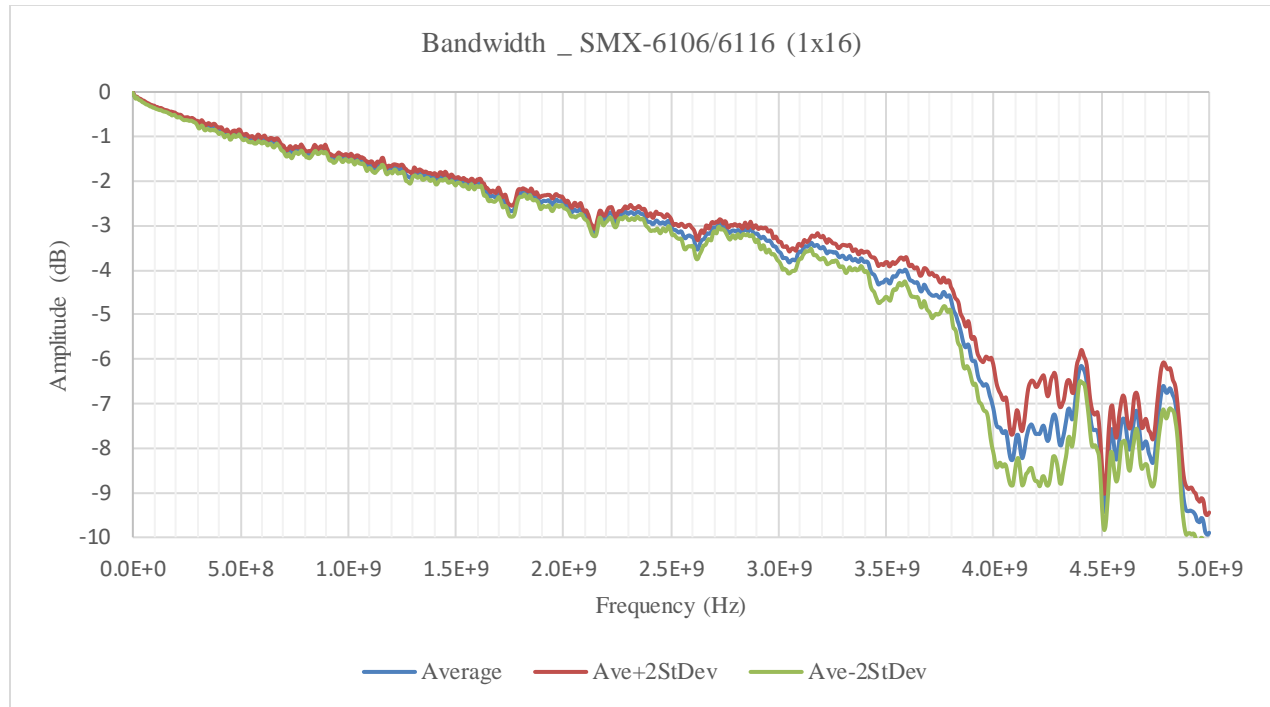

FIGURE 3-115: SMX-6116SMB BANDWIDTH GRAPH

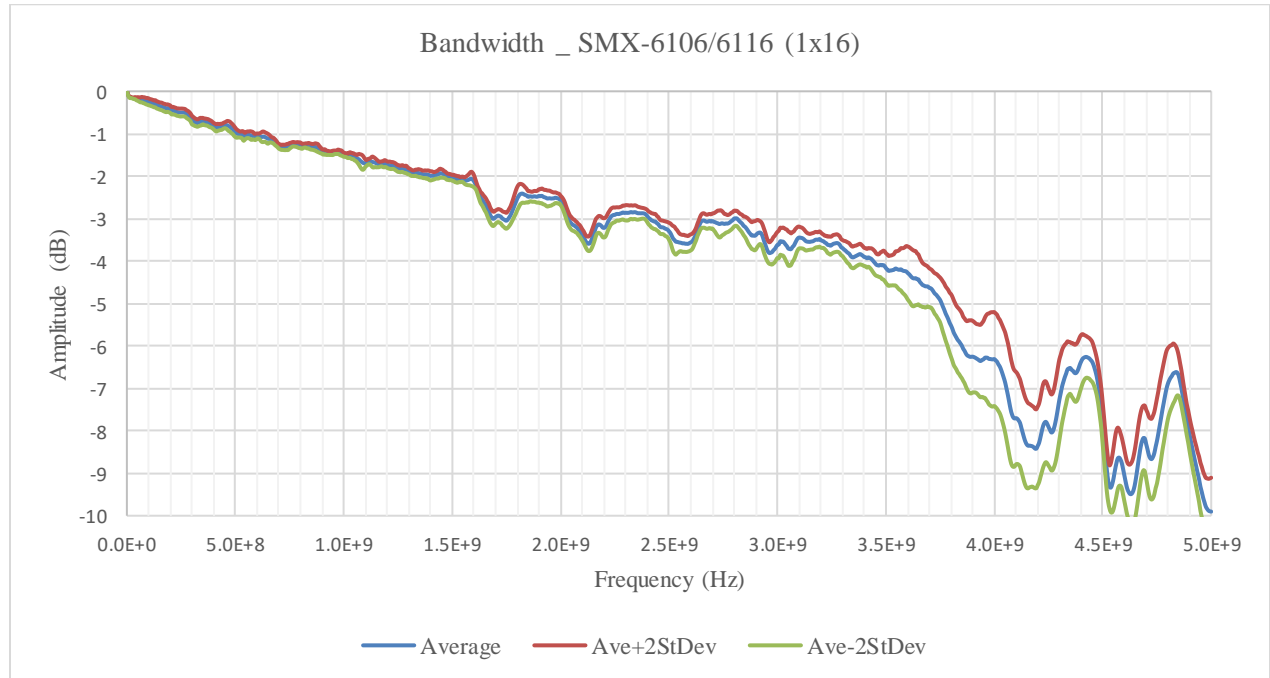

FIGURE 3-116: SMX-6116PKZ BANDWIDTH GRAPH

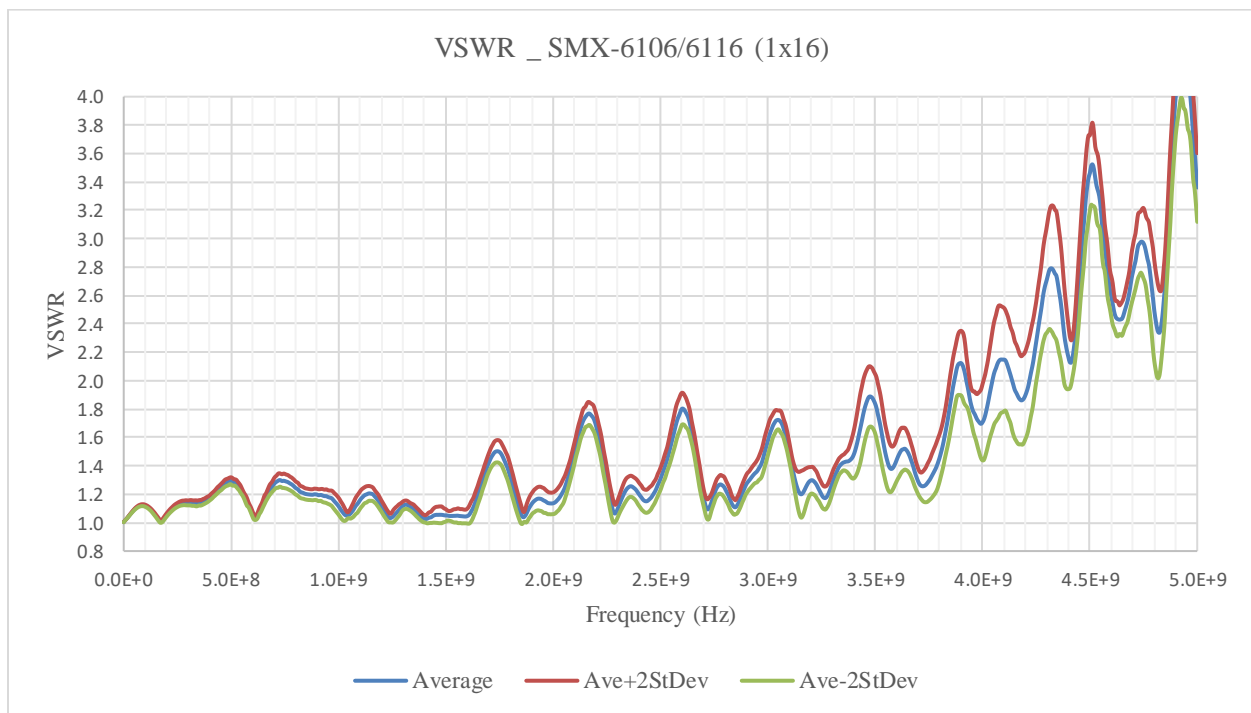

FIGURE 3-117: SMX-6116SMB AND PkZ VSWR GRAPH

SMX-6116 RF SPECIFICATIONS

	SMX-6116/6106 (1x16) SMB	SMX-6116/6106 (1x16) PkZ
Characteristic Impedance	50 Ω	50 Ω
Bandwidth (-3 dB)	2.5 GHz	2 GHz
Insertion Loss @ 3.5 GHz	≤ 4.7 dB	≤ 4.5 dB
Isolation & Crosstalk @ 1.5 GHz	≥ 60 dB	≥ 60 dB
VSWR DC-3.5GHz	2:1 max	2:1 max
Propagation Delay (Typical)	3.5 ns	3.5 ns

TABLE 3-53: SMX-6116 MODEL RF SPECIFICATIONS

SMX-6105 MODULE – RF MUX – 50 OHM

(4) 1X8 COAXIAL MUX UP TO 2.7 GHz

The SMX-6105 module is designed with low frequency RF/uWave multiplexing switching capabilities. This high-density RF switch module is designed for high-fidelity RF switching applications up to 2.7 GHz. It has excellent crosstalk and isolation is maintained by using RF relays along with short low-loss coaxial runs from the connector directly to the relays. This module is also configured to avoid any unterminated stub effects, improving overall signal integrity and allowing for high frequency matrix designs and larger multiplexer configurations while maintaining bandwidth and VSWR.

Front panel connectivity is available in both SMB and PkZ formats to integrate seamlessly into new or existing test systems. Embedded virtual schematic control further simplifies setup and debugging allowing all relays to be engaged independent of application software and device drivers. The SMX-6105 delivers unmatched bandwidth and isolation performance for multi-point connectivity, resulting in exceptional measurement integrity that is ideal for the most demanding aerospace, defense and automotive automated test equipment (ATE) applications.

NOTE SMX-61xx models without SMB in model name are SMX-61xx models with PkZ connector

SMX-6105 CONNECTOR PINS AND SIGNALS

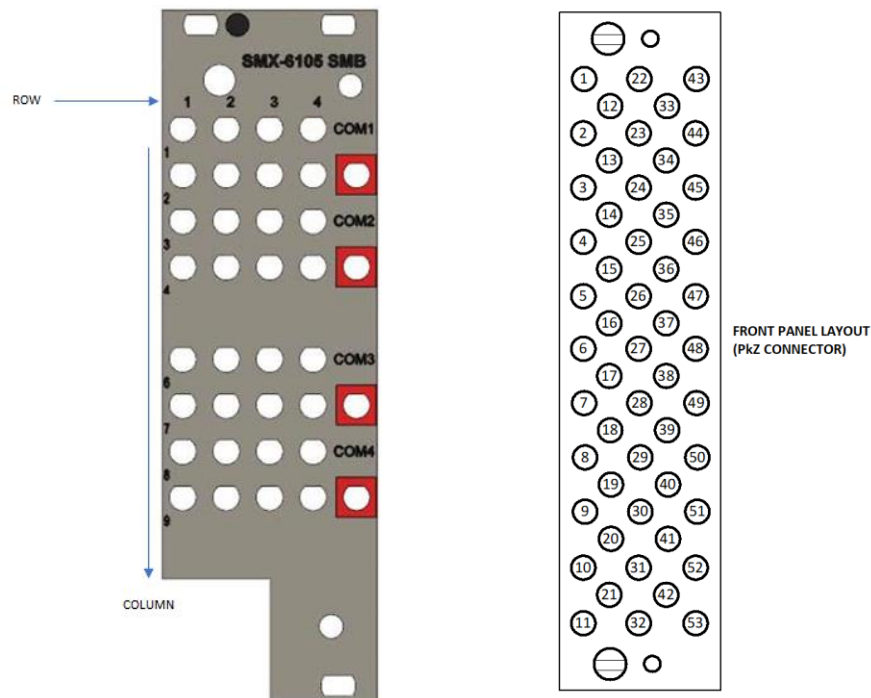

FIGURE 3-118: SMX-6105 FRONT PANEL LAYOUT (SMB CONNECTOR -LEFT IMAGE, PkZ CONNECTOR- RIGHT IMAGE)

***Note: Mapping '1' as CH1 hence 1NO1 refers to CH1_NO1 and COM1 refers to CH1_COM etc.**

PkZ Connector									
1	1NO2			22	1NO3			43	
		12	1NO1			33	1NC		
2	1NO6			23	1NO7			44	COM1
		13	1NO5			34	1NO4		
3	2NO2			24	2NO3			45	
		14	2NO1			35	2NC		
4	2NO6			25	2NO7			46	COM2
		15	2NO5			36	2NO4		
5				26				47	
		16				37			
6	3NO2			27	3NO3			48	
		17	3NO1			38	3NC		
7	3NO6			28	3NO7			49	COM3
		18	3NO5			39	3NO4		
8	4NO2			29	4NO3			50	
		19	4NO1			40	4NC		
9	4NO6			30	4NO7			51	COM4
		20	4NO5			41	4NO4		
10				31				52	
		21				42			
11				32				53	

TABLE 3-54: SMX-6105 PkZ CONNECTOR PINS & SIGNAL ASSIGNMENTS

	1	2	3	4	COM
1	11	12	13	14	COM1
2	21	22	23	24	
3	31	32	33	34	COM2
4	41	42	43	44	
6	61	62	63	64	COM3
7	71	72	73	74	
8	81	82	83	84	COM4
9	91	92	93	94	

SMB Connector				
1NC	11		3NC	61
1NO1	12		3NO1	62
1NO2	13		3NO2	63
1NO3	14		3NO3	64
1NO4	21		3NO4	71
1NO5	22		3NO5	72
1NO6	23		3NO6	73
1NO7	24		3NO7	74
COM1			COM3	
2NC	31		4NC	81
2NO1	32		4NO1	82
2NO2	33		4NO2	83
2NO3	34		4NO3	84
2NO4	41		4NO4	91
2NO5	42		4NO5	92
2NO6	43		4NO6	93
2NO7	44		4NO7	94
COM2			COM4	

TABLE 3-55: SMX- 6105 SMB PIN MAPPING

NOTE In the above SMB PIN MAPPING table read the connector number as Row and then Column (ex., 11, 12, 21, 22...etc.)

SMX-6105 PkZ LOGICAL DIAGRAM

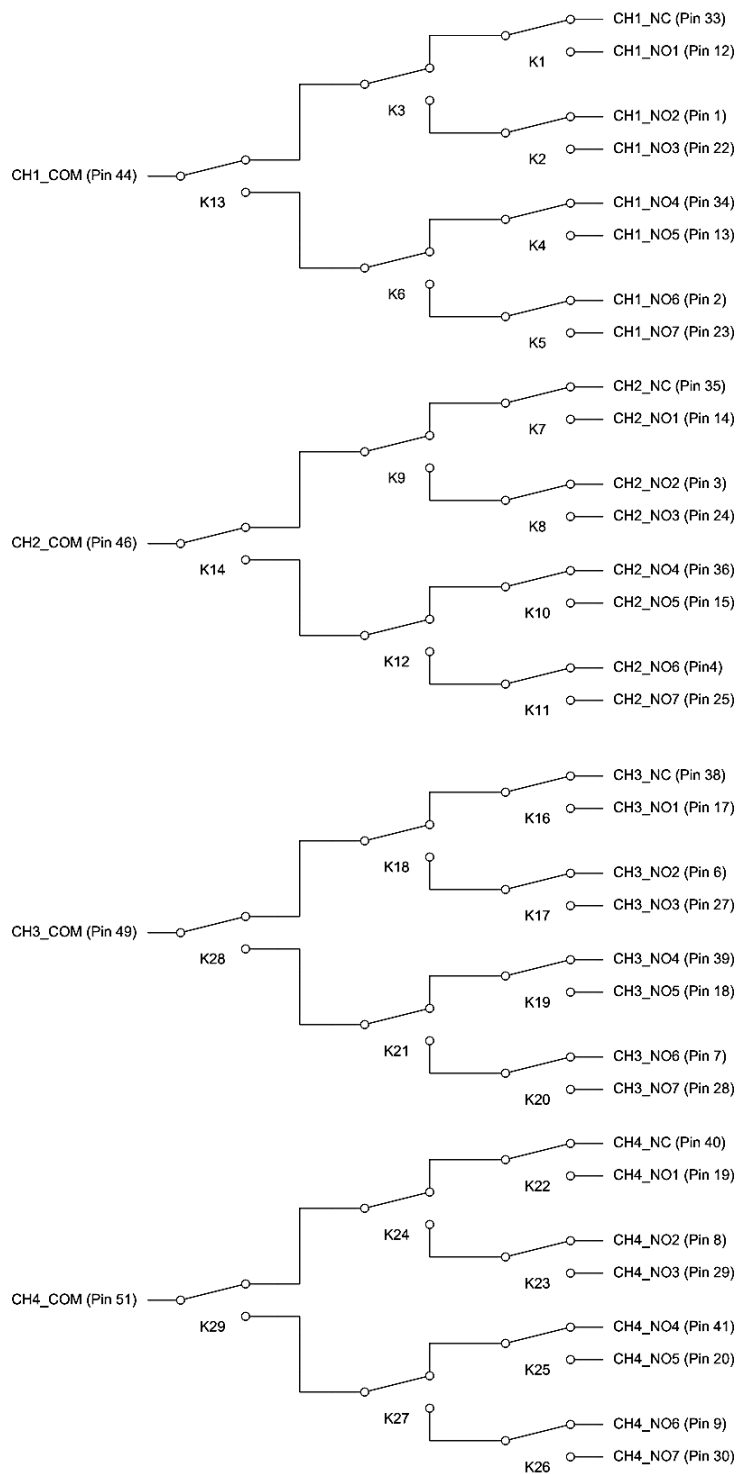

FIGURE 3-119: SMX-6105PkZ LOGICAL DIAGRAM

SMX-6105 SMB LOGICAL DIAGRAM

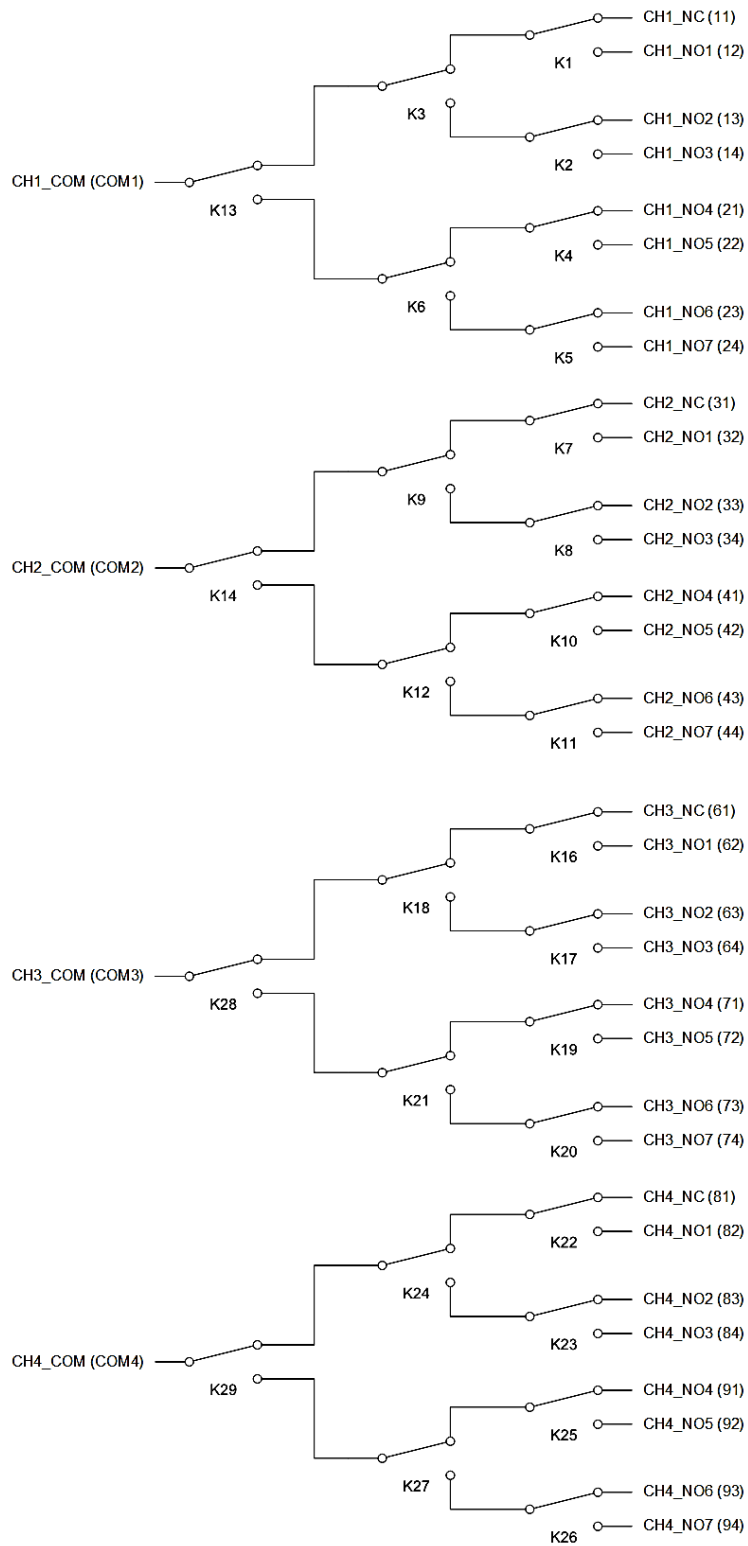

FIGURE 3-120: SMX-6105SMB LOGICAL DIAGRAM

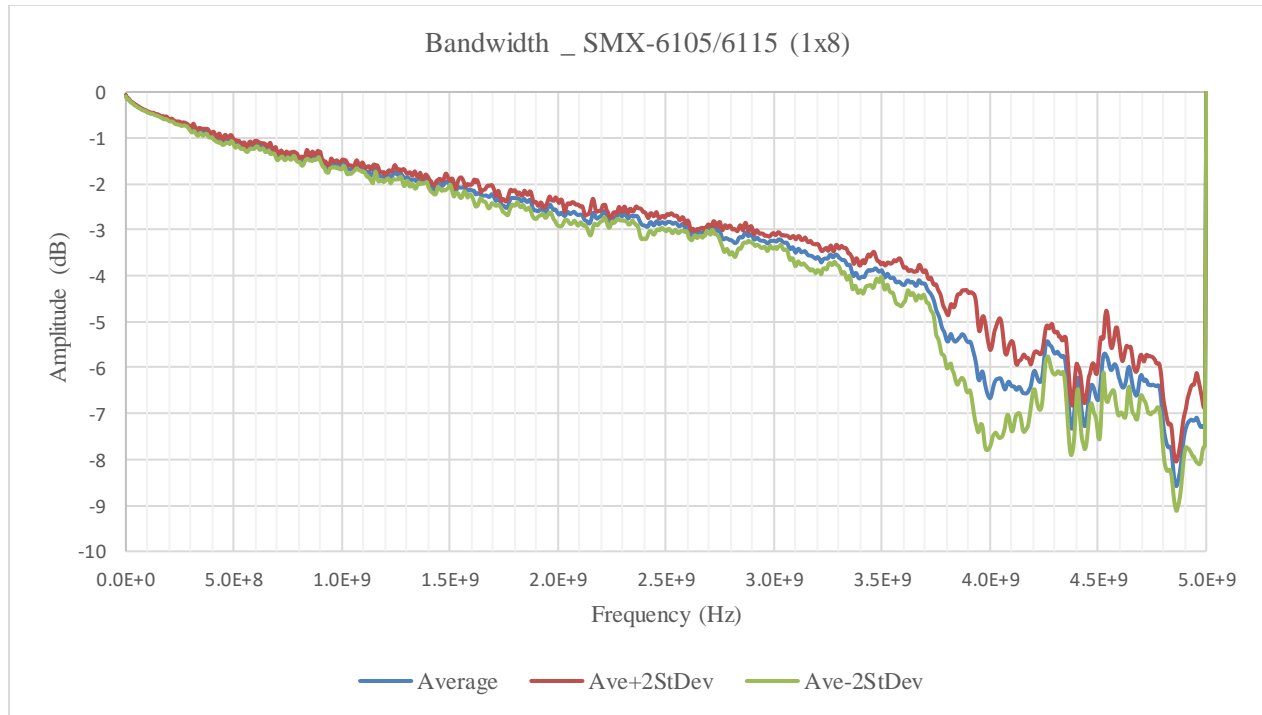

FIGURE 3-121: SMX-6105SMB BANDWIDTH GRAPH

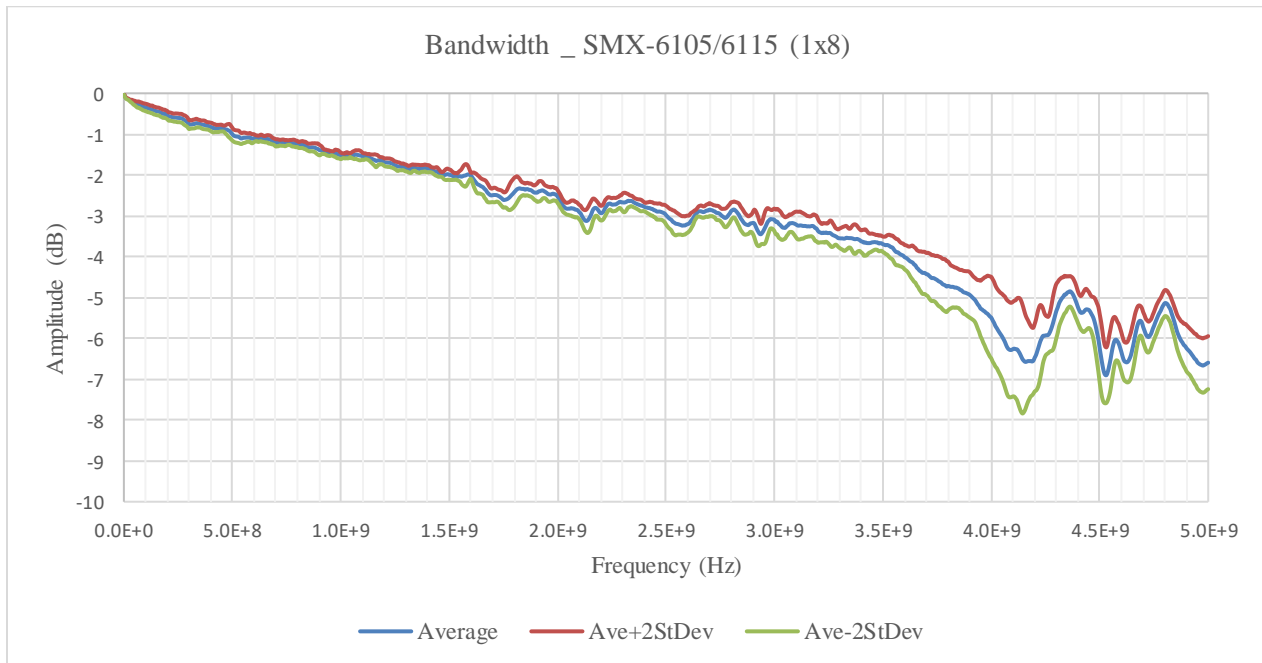

FIGURE 3-122: SMX-6105PkZ BANDWIDTH GRAPH

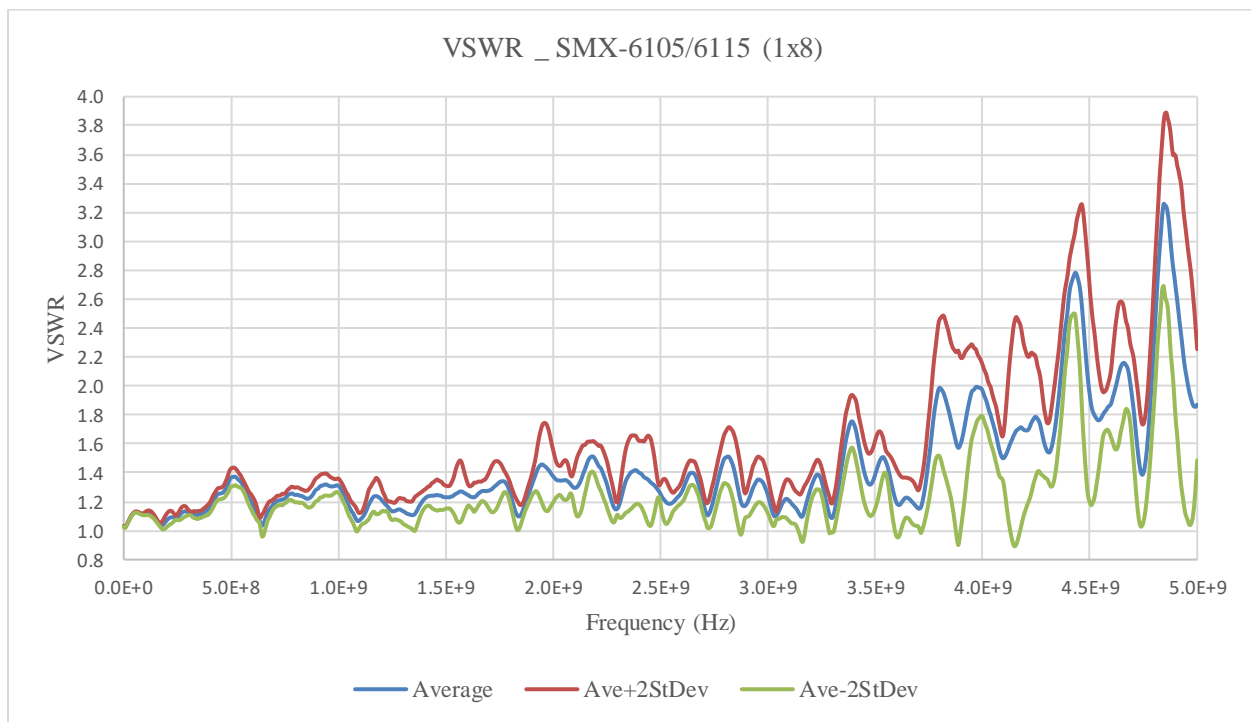

FIGURE 3-123: SMX-6105SMB VSWR GRAPH

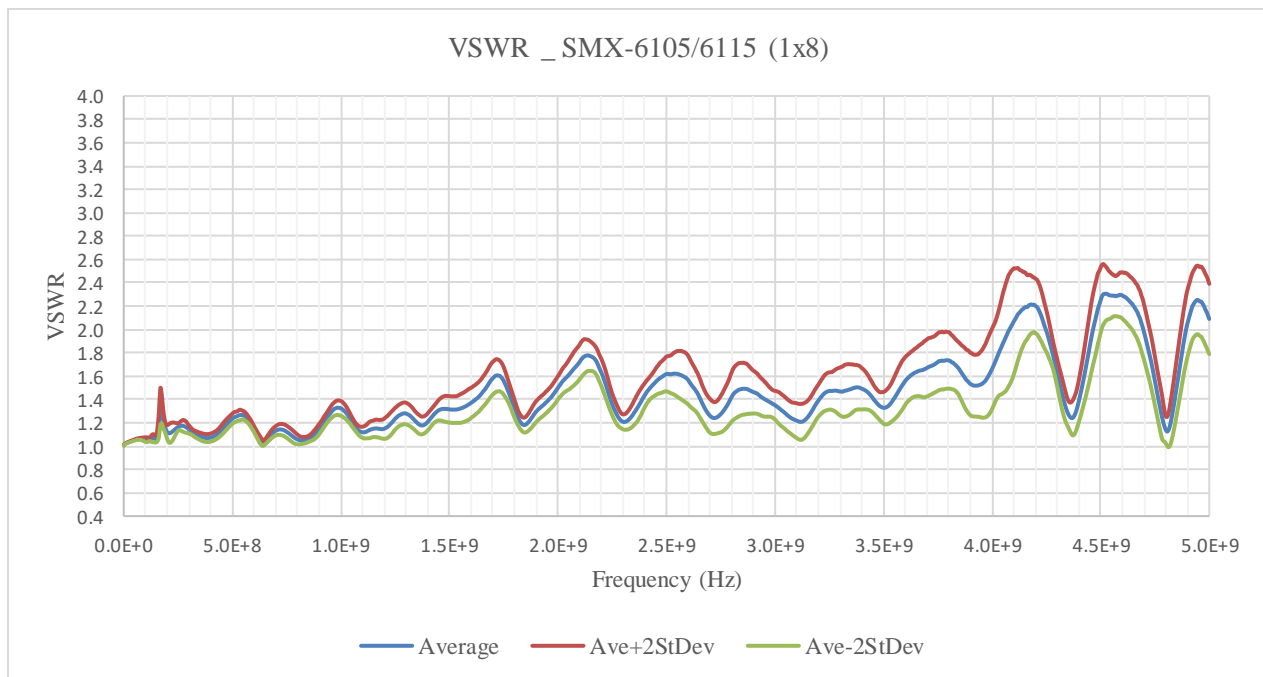

FIGURE 3-124: SMX-6105PkZ VSWR GRAPH

SMX-6105 RF SPECIFICATIONS

	SMX-6105/6115 (1x8) SMB	SMX-6105/6115 (1x8) PkZ
Characteristic Impedance	50 Ω	50 Ω
Bandwidth (-3 dB)	2.7 GHz	2.5 GHz
Insertion Loss @ 3.5 GHz	≤ 4.4 dB	≤ 3.8 dB
Isolation & Crosstalk @ 1.5 GHz	≥ 60 dB	≥ 60 dB
VSWR DC-3.5GHz	2:1 max	2:1 max
Propagation Delay (Typical)	3.5 ns	3.5 ns

TABLE 3-56: SMX-6105 MODEL RF SPECIFICATIONS

SMX-6115 MODULE – RF MUX – 50 OHM

(2) 1X8 COAXIAL MUX UP TO 2.7 GHz

The SMX-6115 module is designed with low frequency RF/uWave multiplexing switching capabilities. This high-density RF switch module is designed for high-fidelity RF switching applications up to 2.7 GHz. It has excellent crosstalk and isolation is maintained by using RF relays along with short low-loss coaxial runs from the connector directly to the relays. This module is also configured to avoid any unterminated stub effects, improving overall signal integrity and allowing for high frequency matrix designs and larger multiplexer configurations while maintaining bandwidth and VSWR.

Front panel connectivity is available in both SMB and PkZ formats to integrate seamlessly into new or existing test systems. Embedded virtual schematic control further simplifies setup and debugging allowing all relays to be engaged independent of application software and device drivers. The SMX-6115 delivers unmatched bandwidth and isolation performance for multi-point connectivity, resulting in exceptional measurement integrity that is ideal for the most demanding aerospace, defense and automotive automated test equipment (ATE) applications.

NOTE SMX-61xx models without SMB in model name are SMX-61xx models with PkZ connector

SMX-6115 CONNECTOR PINS AND SIGNALS

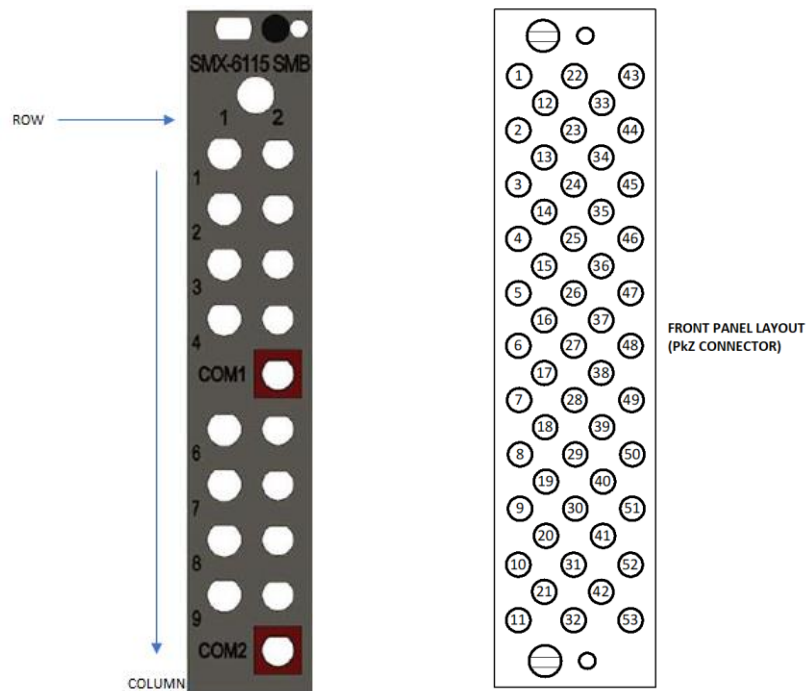

FIGURE 3-125: SMX-6115 FRONT PANEL LAYOUT (SMB CONNECTOR -LEFT IMAGE, PkZ CONNECTOR- RIGHT IMAGE)

**Note: Mapping '1' as CH1 hence 1NO1 refers to CH1_NO1 and COM1 refers to CH1_COM etc.*

PkZ Connector									
1	1NO2			22	1NO3			43	
		12	1NO1			33	1NC		
2	1NO6			23	1NO7			44	COM1
		13	1NO5			34	1NO4		
3	2NO2			24	2NO3			45	
		14	2NO1			35	2NC		
4	2NO6			25	2NO7			46	COM2
		15	2NO5			36	2NO4		
5				26				47	
		16				37			
6				27				48	
		17				38			
7				28				49	
		18				39			
8				29				50	
		19				40			
9				30				51	
		20				41			
10				31				52	
		21				42			
11				32				53	

TABLE 3-57: SMX-6115 PkZ CONNECTOR PINS & SIGNAL ASSIGNMENTS

	1	2	COM
1	11	12	COM1
2	21	22	
3	31	32	
4	41	42	
6	61	62	COM2
7	71	72	
8	81	82	
9	91	92	

SMB Connector	
1NC	11
1NO1	12
1NO2	21
1NO3	22
1NO4	31
1NO5	32
1NO6	41
1NO7	42
COM1	
2NC	61
2NO1	62
2NO2	71
2NO3	72
2NO4	81
2NO5	82
2NO6	91
2NO7	92
COM2	

TABLE 3-58: SMX- 6115 SMB PIN MAPPING

NOTE In the above SMB PIN MAPPING table read the connector number as Row and then Column (ex., 11, 12, 21, 22...etc.)

SMX-6115 PkZ LOGICAL DIAGRAM

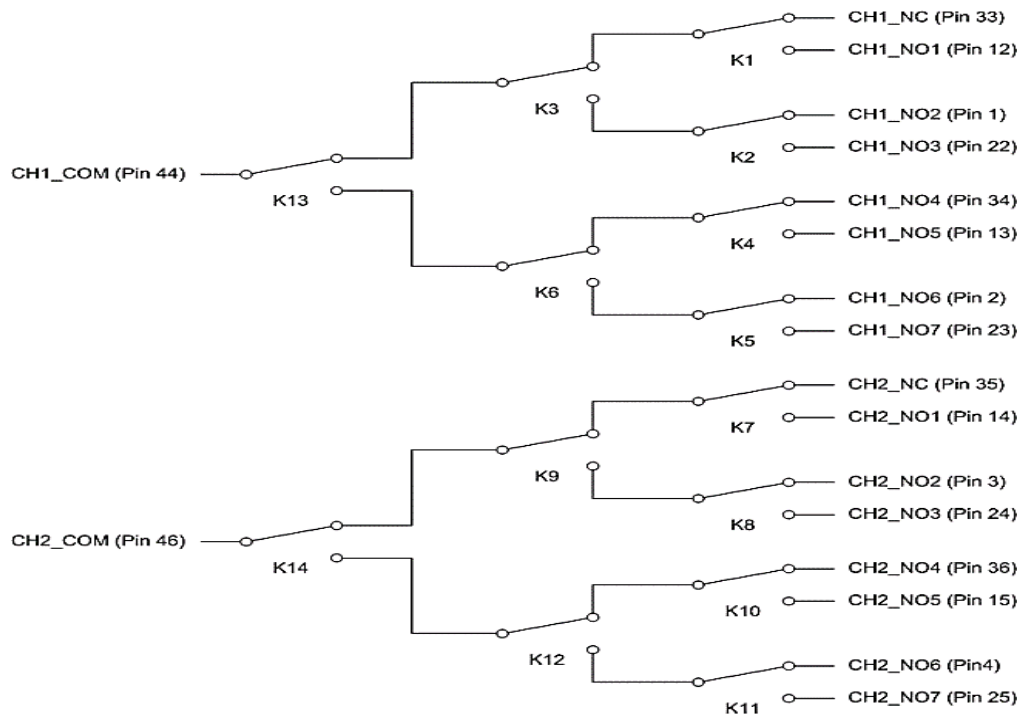

FIGURE 3-126: SMX-6115PkZ LOGICAL DIAGRAM

SMX-6115 SMB LOGICAL DIAGRAM

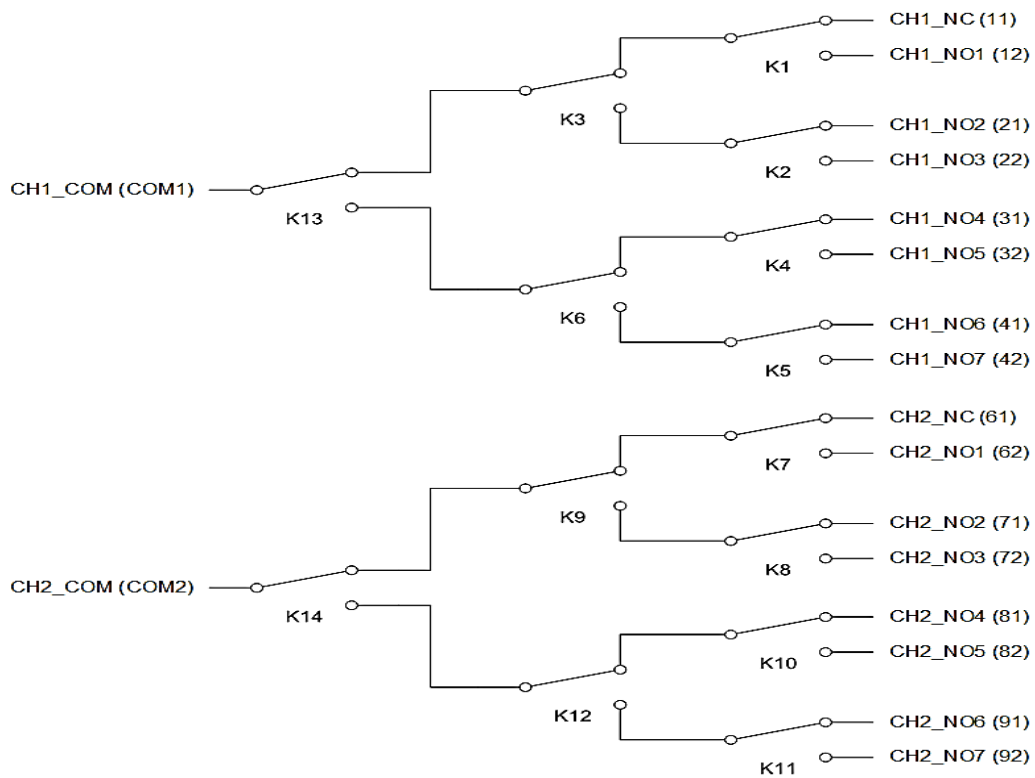

FIGURE 3-127: SMX-6115SMB LOGICAL DIAGRAM

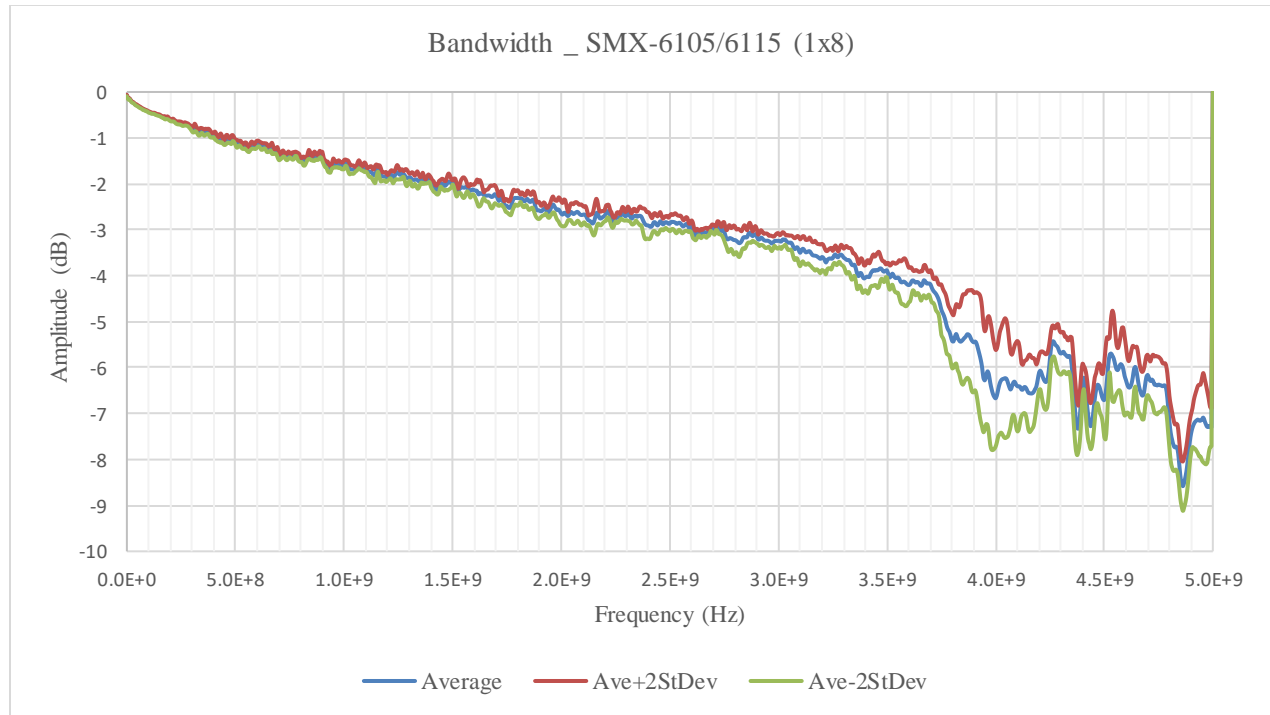

FIGURE 3-128: SMX-6115SMBBANDWIDTH GRAPH

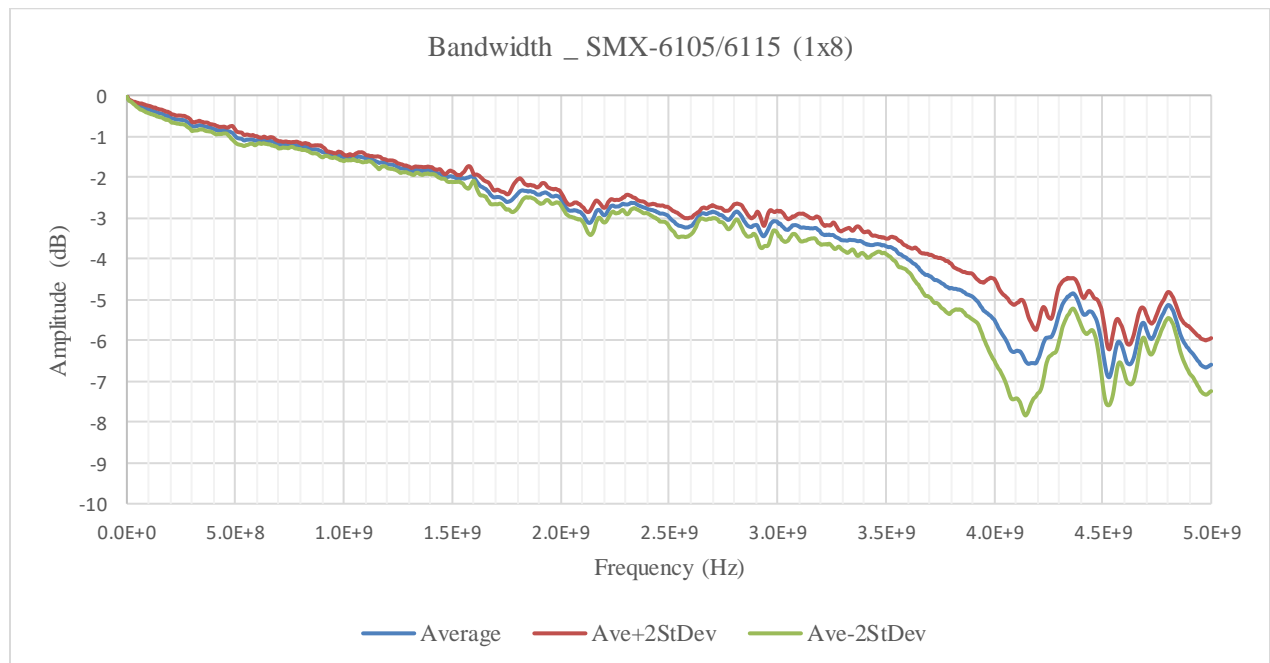

FIGURE 3-129: SMX-6115PkZBANDWIDTH GRAPH

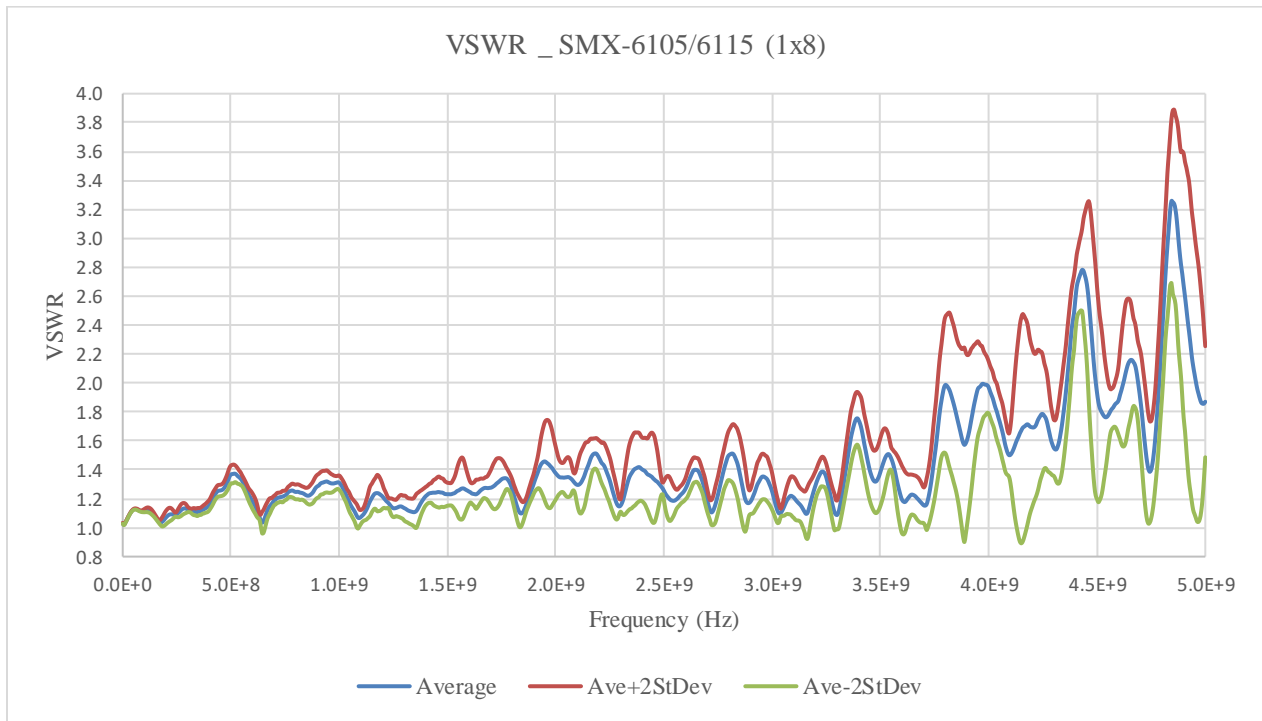

FIGURE 3-130: SMX-6115SMB VSWR GRAPH

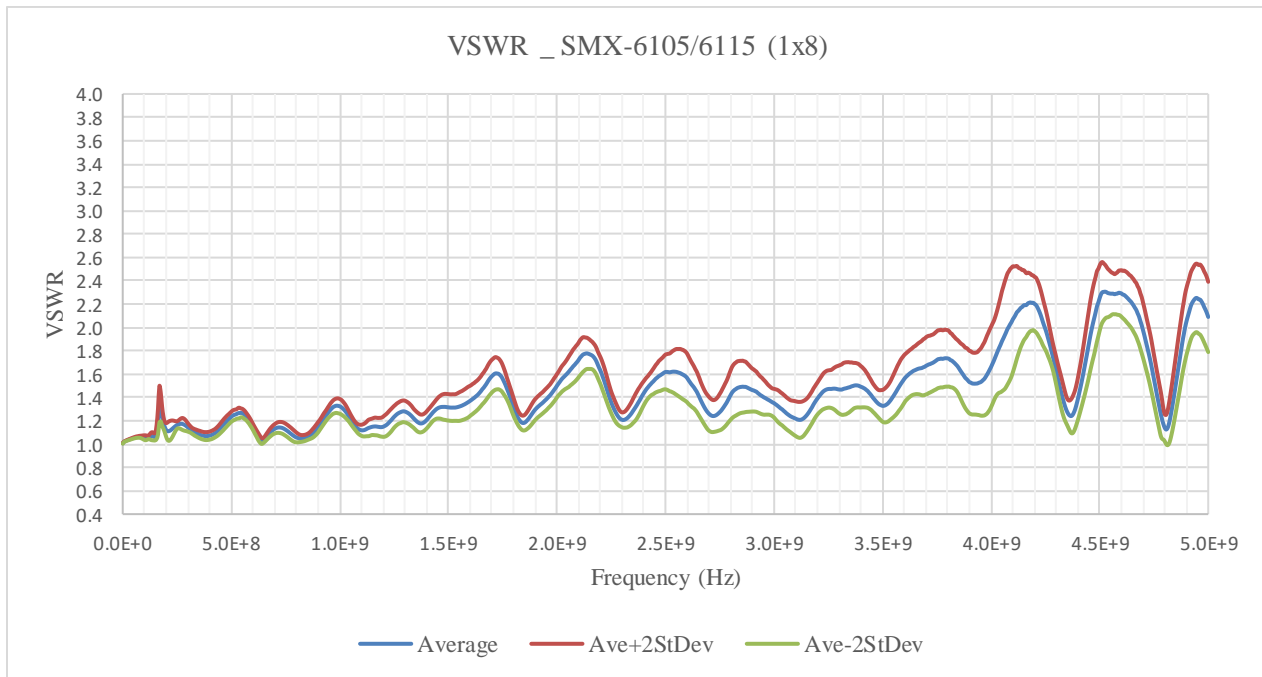

FIGURE 3-131: SMX-6115PkZ VSWR GRAPH

SMX-6115 RF SPECIFICATIONS

	SMX-6115/6105 (1x8) SMB	SMX-6115/6105 (1x8) PkZ
Characteristic Impedance	50 Ω	50 Ω
Bandwidth (-3 dB)	2.7 GHz	2.5 GHz
Insertion Loss @ 3.5 GHz	≤ 4.4 dB	≤ 3.8 dB
Isolation & Crosstalk @ 1.5 GHz	≥ 60 dB	≥ 60 dB
VSWR DC-3.5GHz	2:1 max	2:1 max
Propagation Delay (Typical)	3.5 ns	3.5 ns

TABLE 3-59: SMX-6115 MODEL RF SPECIFICATIONS

SMX-6103 MODULE – RF MUX – 50 OHM

(1) 1X32 COAXIAL MUX UP TO 1.5 GHz

The SMX-6103 module is designed with low frequency RF/uWave multiplexing switching capabilities. This high-density RF switch module is designed for high-fidelity RF switching applications up to 1.5 GHz. It has excellent crosstalk and isolation is maintained by using RF relays along with short low-loss coaxial runs from the connector directly to the relays. This module is also configured to avoid any unterminated stub effects, improving overall signal integrity and allowing for high frequency matrix designs and larger multiplexer configurations while maintaining bandwidth and VSWR.

Front panel connectivity is available in both SMB and PkZ formats to integrate seamlessly into new or existing test systems. Embedded virtual schematic control further simplifies setup and debugging allowing all relays to be engaged independent of application software and device drivers. The SMX-6103 delivers unmatched bandwidth and isolation performance for multi-point connectivity, resulting in exceptional measurement integrity that is ideal for the most demanding aerospace, defense and automotive automated test equipment (ATE) applications.

NOTE SMX-61xx models without SMB in model name are SMX-61xx models with PkZ connector

SMX-6103 CONNECTOR PINS AND SIGNALS

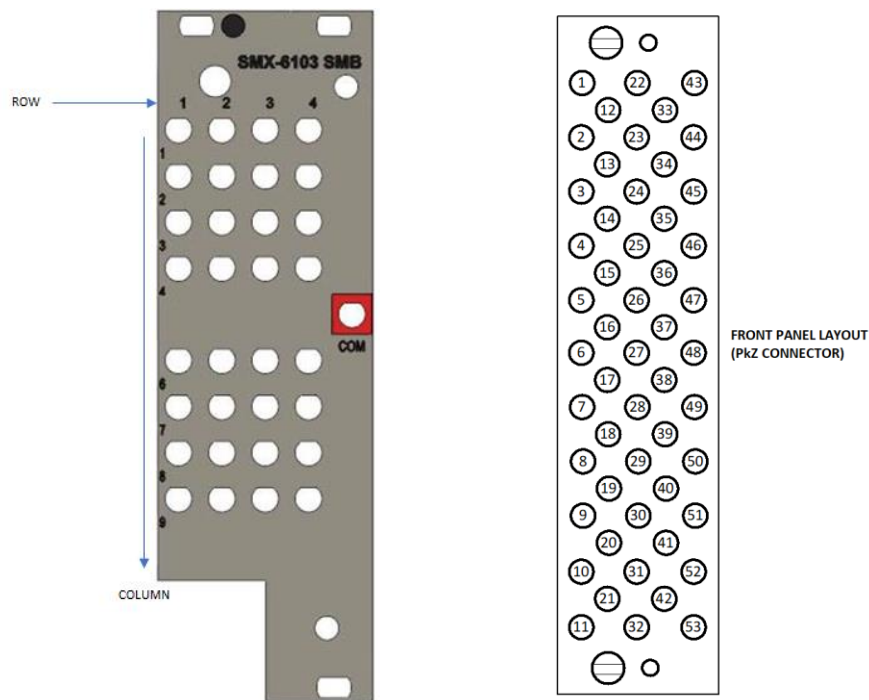

FIGURE 3-132: SMX-6103 FRONT PANEL LAYOUT (SMB CONNECTOR -LEFT IMAGE, PkZ CONNECTOR- RIGHT IMAGE)

**Note: Mapping '1' as CH1 hence 1NO1 refers to CH1_NO1 and COM1 refers to CH1_COM etc.*

PkZ Connector									
1	NO2			22	NO3			43	
		12	NO1			33	NC		
2	NO6			23	NO7			44	
		13	NO5			34	NO4		
3	NO10			24	NO11			45	
		14	NO9			35	NO8		
4	NO14			25	NO15			46	
		15	NO13			36	NO12		
5				26				47	COM
		16				37			
6	NO18			27	NO19			48	
		17	NO17			38	NO16		
7	NO22			28	NO23			49	
		18	NO21			39	NO20		
8	NO26			29	NO27			50	
		19	NO25			40	NO24		
9	NO30			30	NO31			51	
		20	NO29			41	NO28		
10				31				52	
		21				42			
11				32				53	

TABLE 3-60: SMX-6103 PkZ CONNECTOR PINS & SIGNAL ASSIGNMENTS

	1	2	3	4	COM
1	11	12	13	14	COM
2	21	22	23	24	
3	31	32	33	34	
4	41	42	43	44	
6	61	62	63	64	
7	71	72	73	74	
8	81	82	83	84	
9	91	92	93	94	

SMB Connector			
NC	11	NO16	61
NO1	12	NO17	62
NO2	13	NO18	63
NO3	14	NO19	64
NO4	21	NO20	71
NO5	22	NO21	72
NO6	23	NO22	73
NO7	24	NO23	74
NO8	31	NO24	81
NO9	32	NO25	82
NO10	33	NO26	83
NO11	34	NO27	84
NO12	41	NO28	91
NO13	42	NO29	92
NO14	43	NO30	93
NO15	44	NO31	94
		COM	COM

TABLE 3-61: SMX-6103 SMB PIN MAPPING

NOTE In the above SMB PIN MAPPING table read the connector number as Row and then Column (ex., 11, 12, 21, 22...etc.)

SMX-6103 PkZ LOGICAL DIAGRAM

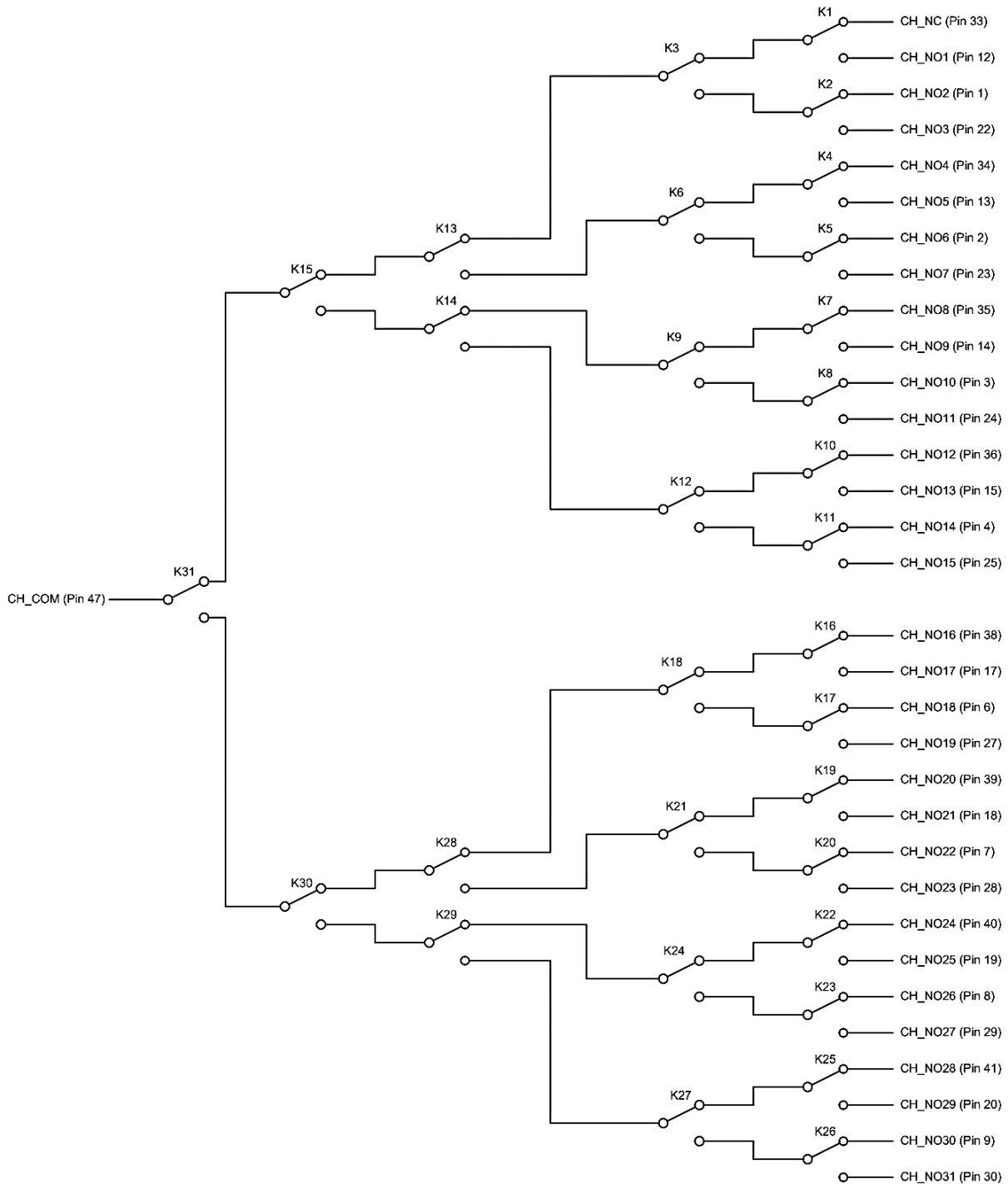

FIGURE 3-133: SMX-6103PkZ LOGICAL DIAGRAM

SMX-6103 SMB LOGICAL DIAGRAM

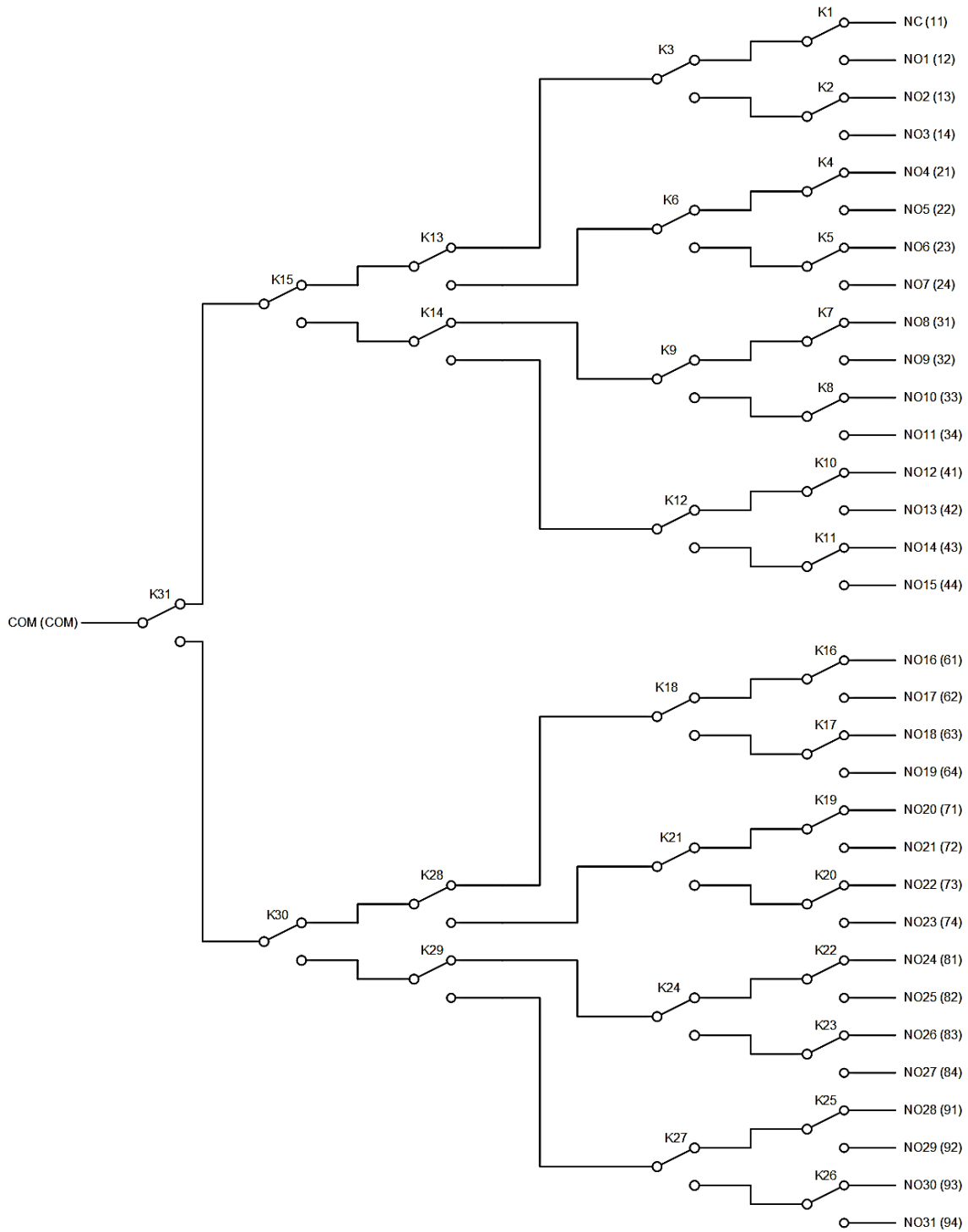

FIGURE 3-134: SMX-6103SMB LOGICAL DIAGRAM

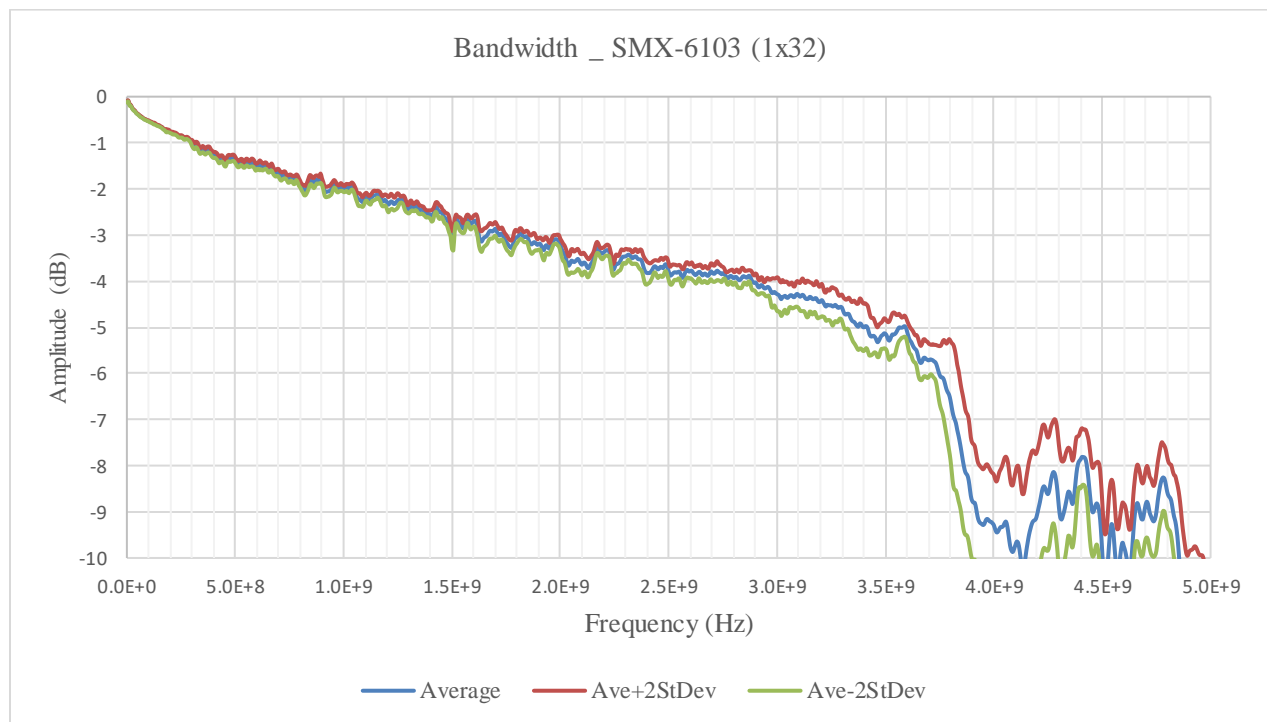

FIGURE 3-135: SMX-6103SMB BANDWIDTH GRAPH

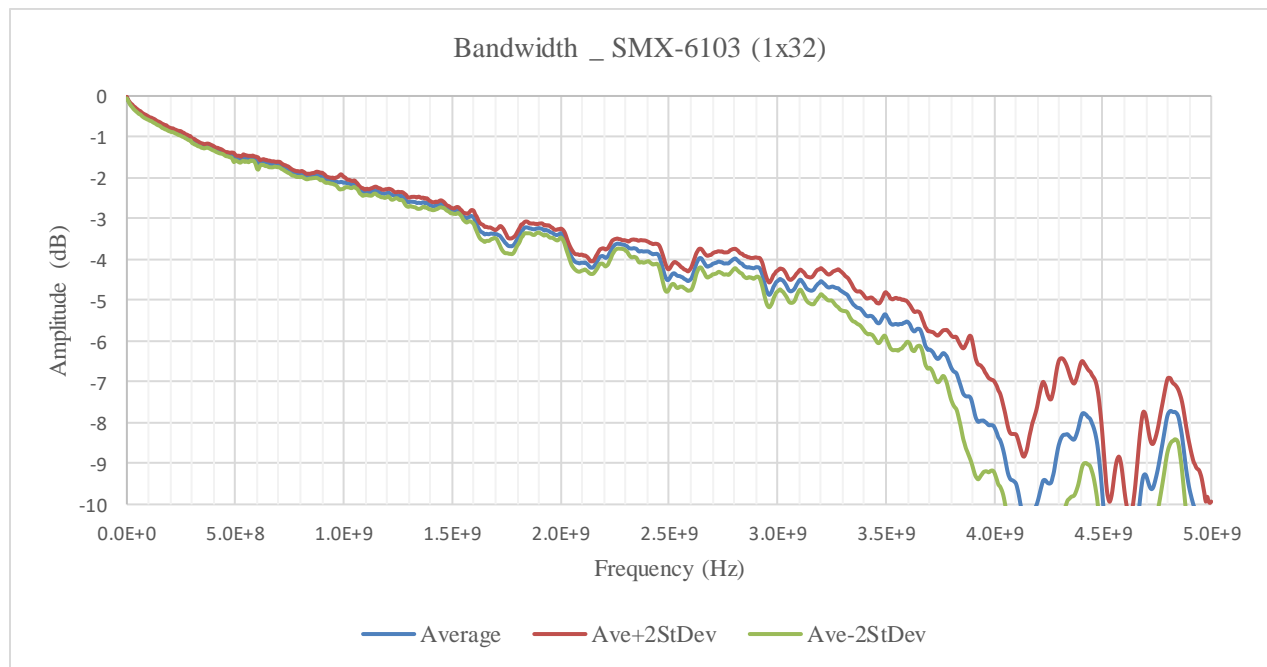

FIGURE 3-136: SMX-6103PKZ BANDWIDTH GRAPH

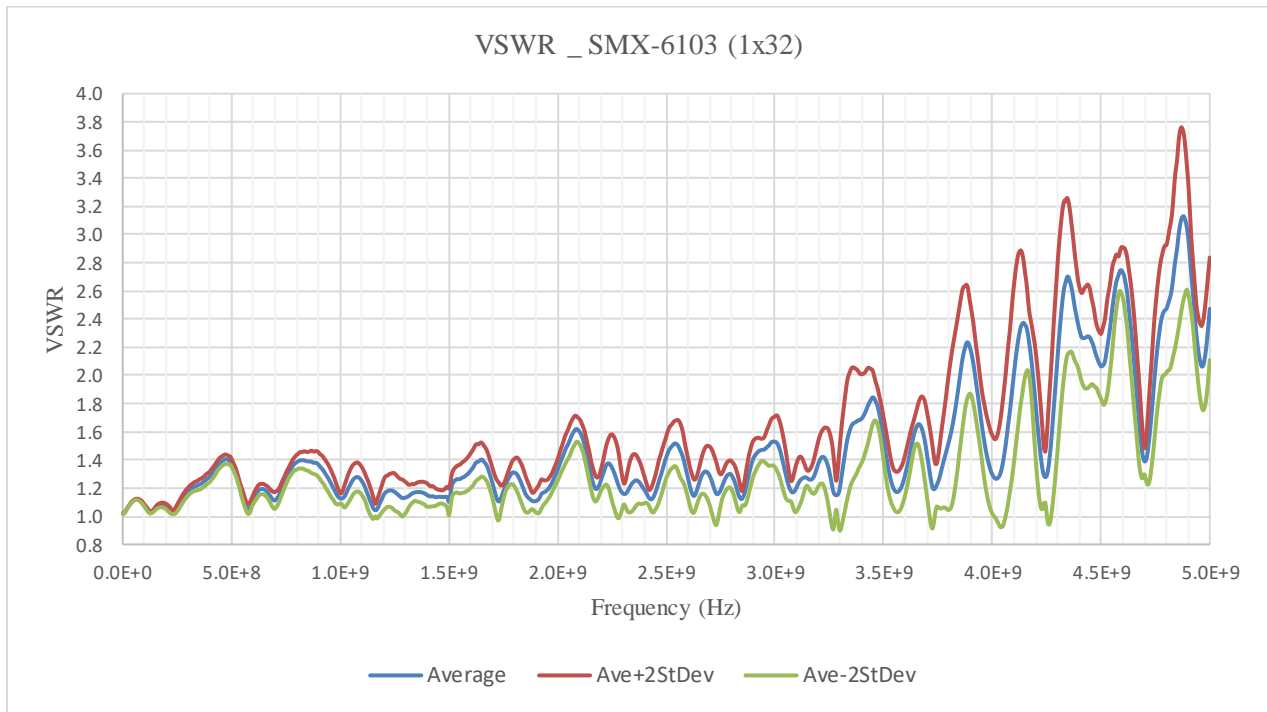

FIGURE 3-137: SMX-6103SMB VSWR GRAPH

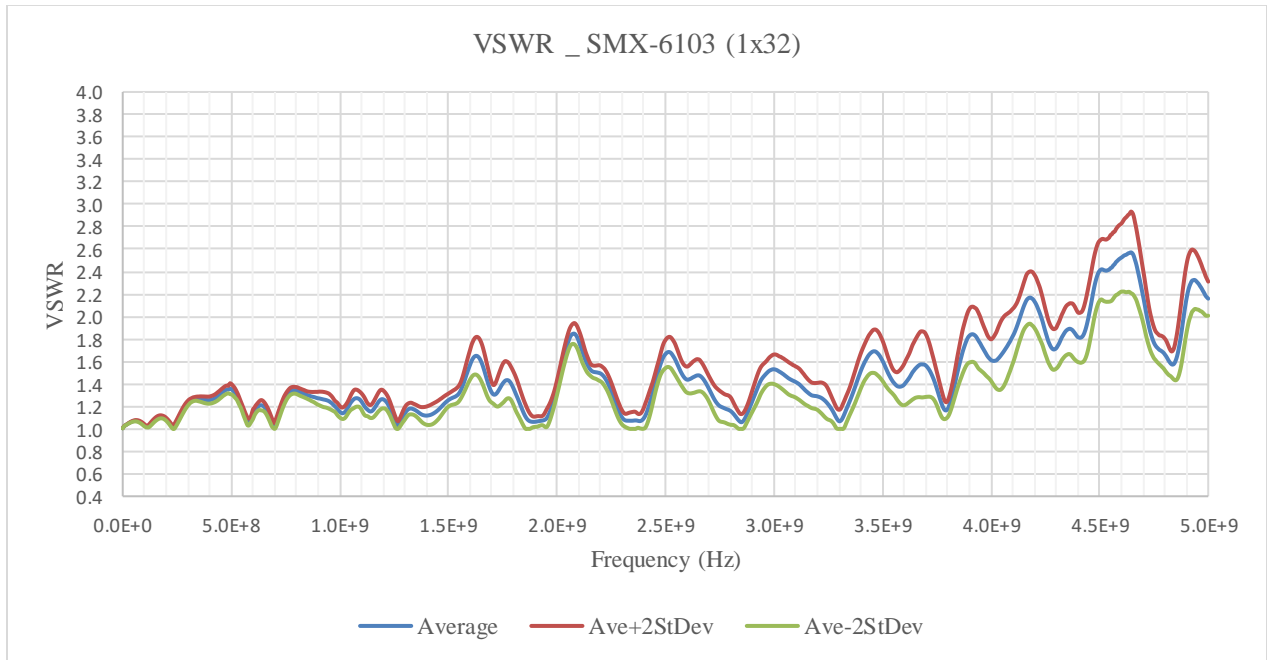

FIGURE 3-138: SMX-6103PKZ VSWR GRAPH

SMX-6103 RF SPECIFICATIONS

	SMX-6103 (1x32) SMB	SMX-6103 (1x32) PkZ
Characteristic Impedance	50 Ω	50 Ω
Bandwidth (-3 dB)	1.5 GHz	1.6 GHz
Insertion Loss @ 3.5 GHz	≤ 5.5 dB	≤ 5.5 dB
Isolation & Crosstalk @ 1.5 GHz	≥ 60 dB	≥ 60 dB
VSWR DC-3.5GHz	2:1 max	2:1 max
Propagation Delay (Typical)	4.5 ns	4.5 ns

TABLE 3-62: SMX-6103 MODEL RF SPECIFICATIONS

SMX-6144 MODULE – RF MATRIX – 50 OHM

(1) 4X4 COAXIAL MATRIX UP TO 2.0 GHz

The SMX-6144 module is designed with low frequency RF/uWave matrix switching capabilities. This high-density RF switch module is designed for high-fidelity RF switching applications up to 2.0 GHz. It has excellent crosstalk and isolation is maintained by using RF relays along with short low-loss coaxial runs from the connector directly to the relays. This module is also configured to avoid any unterminated stub effects, improving overall signal integrity and allowing for high frequency matrix designs and larger multiplexer configurations while maintaining bandwidth and VSWR.

Front panel connectivity is available in both SMB and PkZ formats to integrate seamlessly into new or existing test systems. Embedded virtual schematic control further simplifies setup and debugging allowing all relays to be engaged independent of application software and device drivers. The SMX-6144 delivers unmatched bandwidth and isolation performance for multi-point connectivity, resulting in exceptional measurement integrity that is ideal for the most demanding aerospace, defense and automotive automated test equipment (ATE) applications.

NOTE SMX-61xx models without SMB in model name are SMX-61xx models with PkZ connector

SMX-6144 CONNECTOR PINS AND SIGNALS

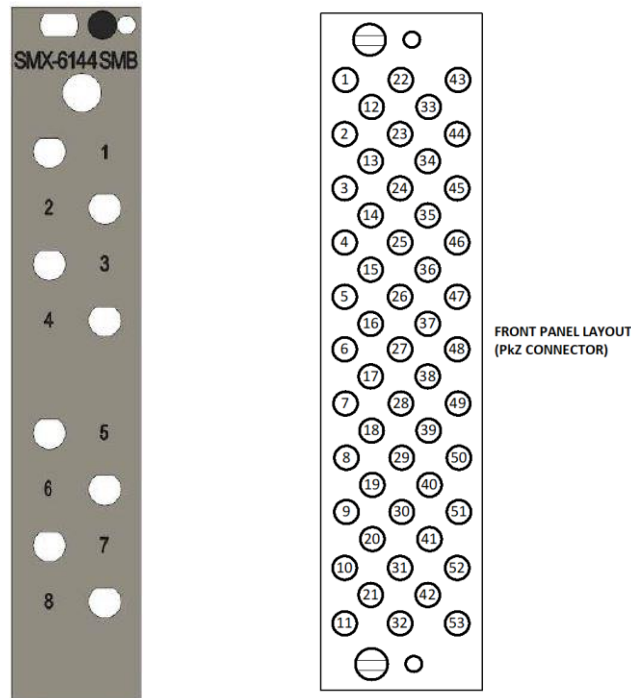

FIGURE 3-139: SMX-6144 FRONT PANEL LAYOUT (SMB CONNECTOR -LEFT IMAGE, PkZ CONNECTOR- RIGHT IMAGE)

**Note: Mapping '1' as CH1 hence 1NO1 refers to CH1_NO1 and COM1 refers to CH1_COM etc.*

PkZ Connector						
1			22		43	CH1A
		12			33	
2			23		44	CH2A
		13			34	
3			24		45	CH3A
		14			35	
4			25		46	CH4A
		15			36	
5			26		47	
		16			37	
6			27		48	CH1B
		17			38	
7			28		49	CH2B
		18			39	
8			29		50	CH3B
		19			40	
9			30		51	CH4B
		20			41	
10			31		52	
		21			42	
11			32		53	

TABLE 3-63: SMX-6144 PkZ CONNECTOR PINS & SIGNAL ASSIGNMENTS

SMB Connector	
CH1A	1
CH2A	2
CH3A	3
CH4A	4
CH1B	5
CH2B	6
CH3B	7
CH5B	8

TABLE 3-64: SMX- 6144 SMB PIN MAPPING

SMX-6144 PkZ LOGICAL DIAGRAM

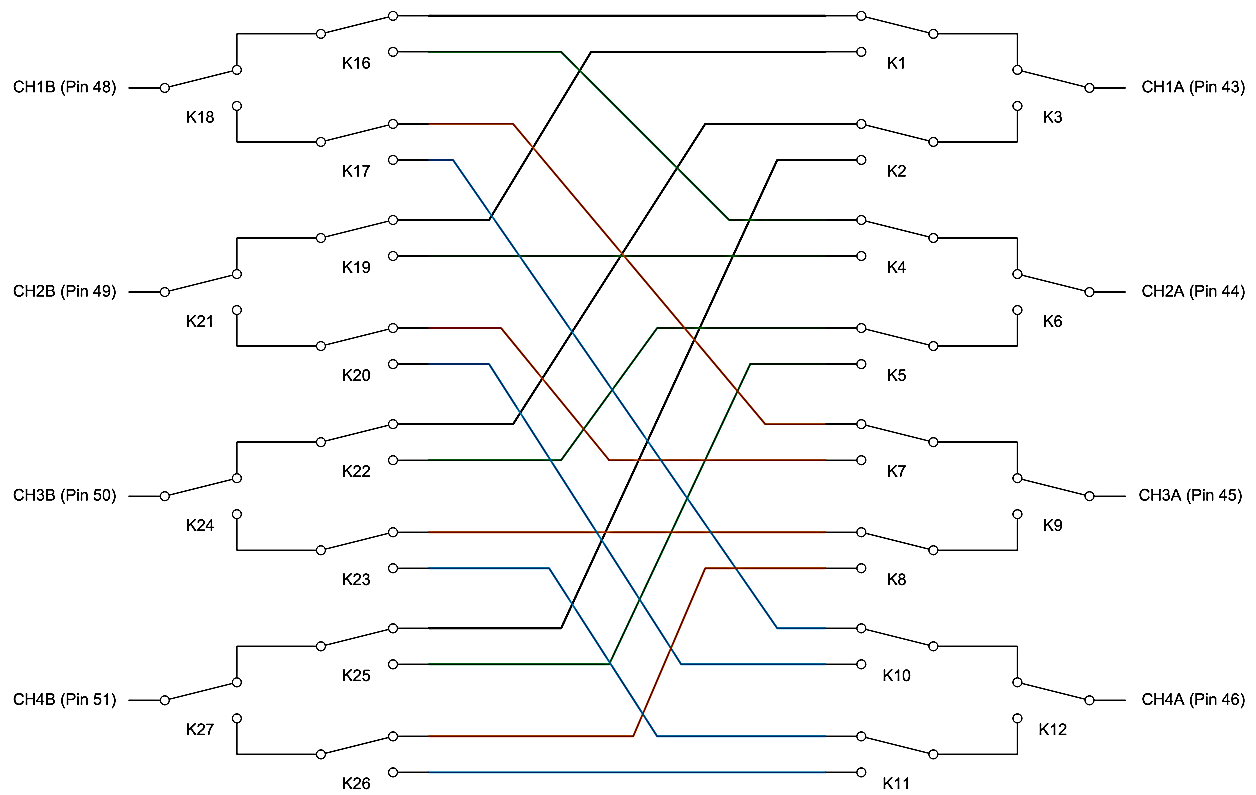

FIGURE 3-140: SMX-6144PkZ LOGICAL DIAGRAM

SMX-6144 SMB LOGICAL DIAGRAM

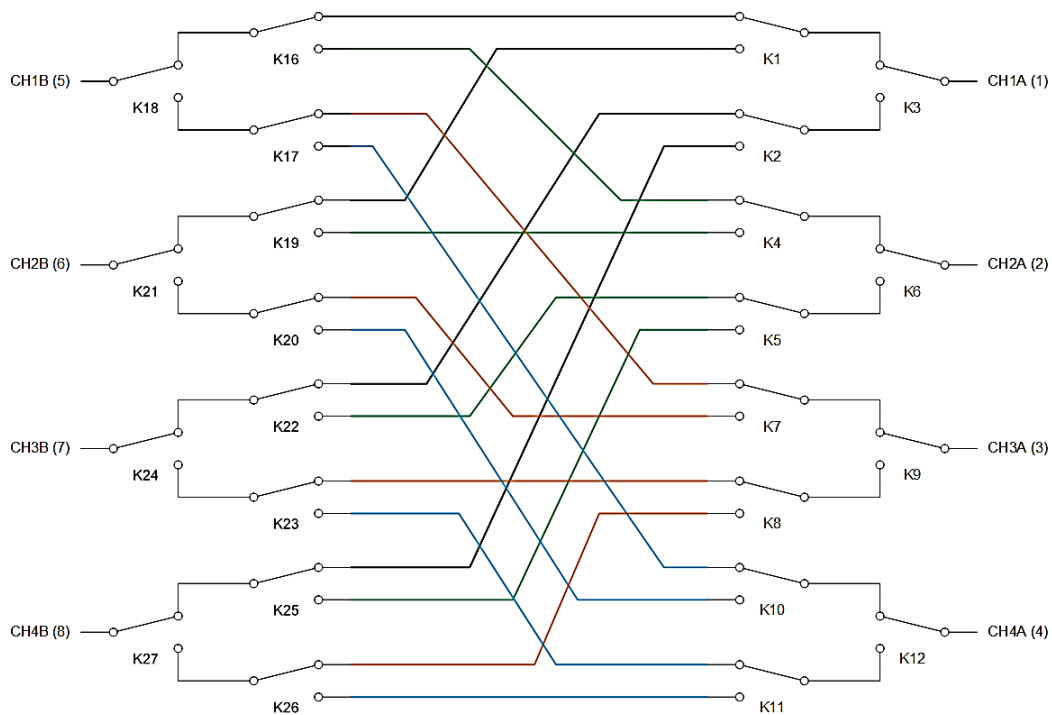

FIGURE 3-141: SMX-6144SMB LOGICAL DIAGRAM

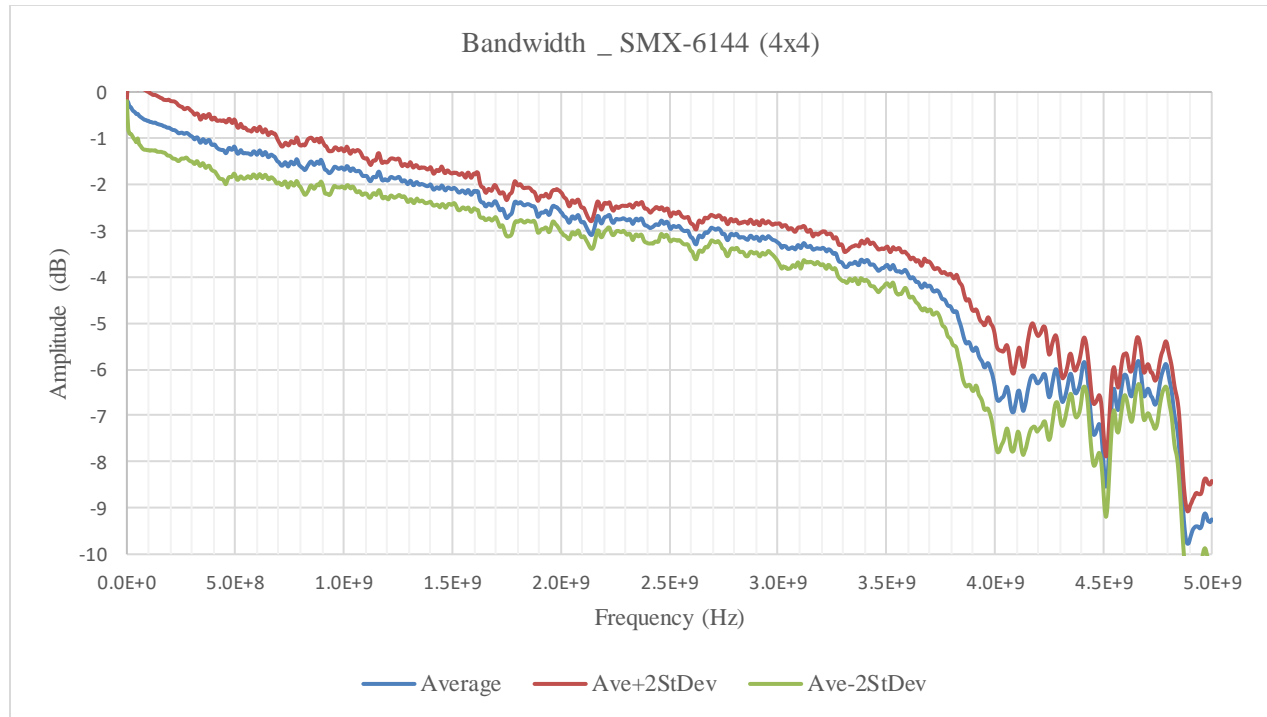

FIGURE 3-142: SMX-6144SMBBANDWIDTH GRAPH

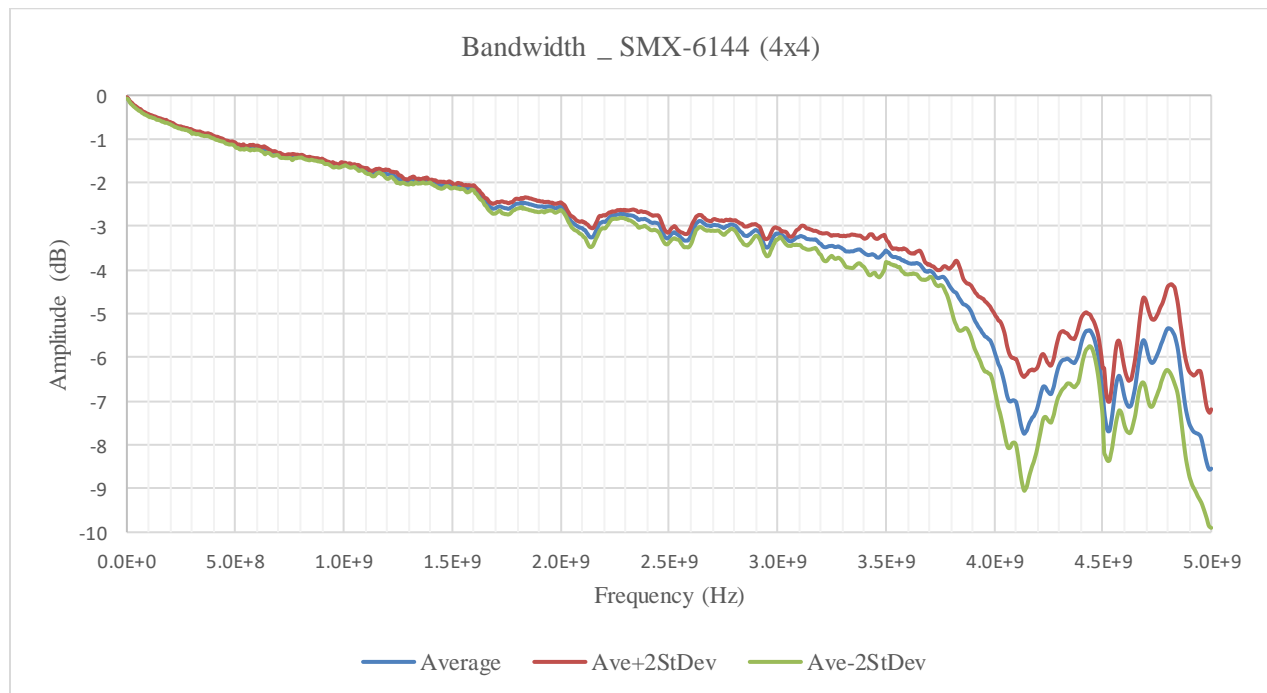

FIGURE 3-143: SMX-6144PkZBANDWIDTH GRAPH

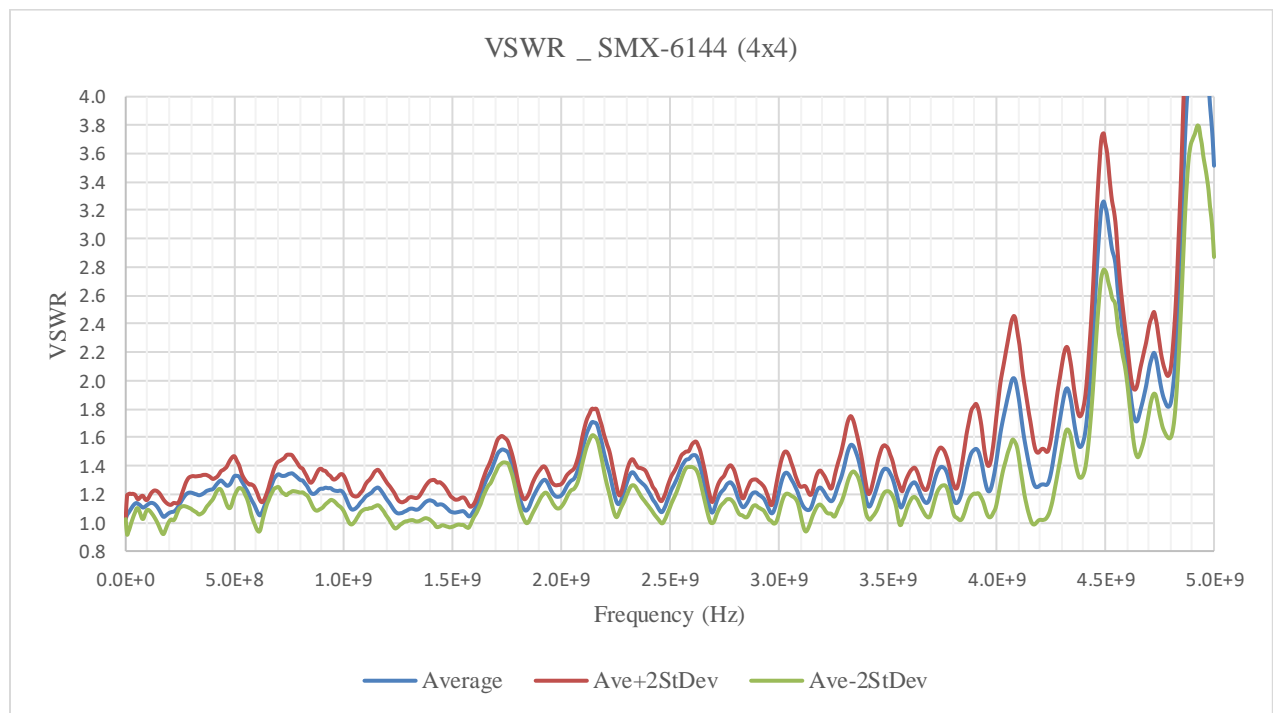

FIGURE 3-144: SMX-6144SMB VSWR GRAPH

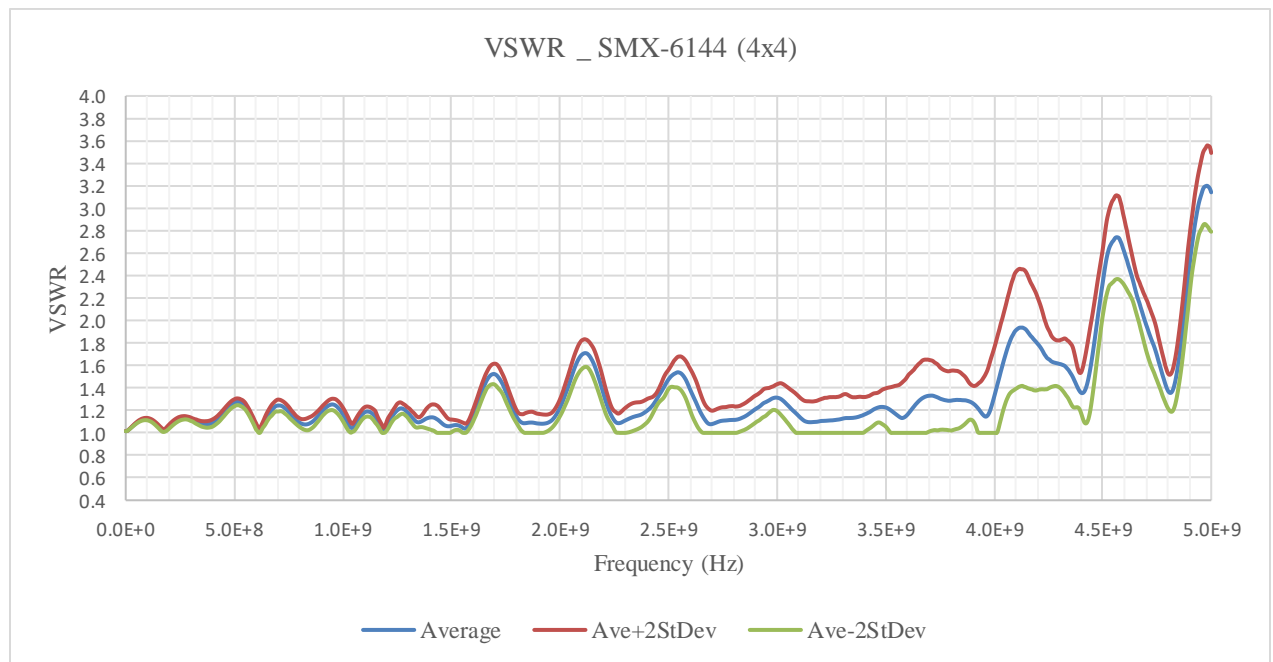

FIGURE 3-145: SMX-6144PkZ VSWR GRAPH

SMX-6144 RF SPECIFICATIONS

	SMX-6144 (4x4) SMB	SMX-6144 (4x4) PkZ
Characteristic Impedance	50 Ω	50 Ω
Bandwidth (-3 dB)	2 GHz	2 GHz
Insertion Loss @ 3.5 GHz	≤ 4.3 dB	≤ 4 dB
Isolation & Crosstalk @ 1.5 GHz	≥ 60 dB	≥ 60 dB
VSWR DC-3.5GHz	2:1 max	2:1 max
Propagation Delay (Typical)	3.5 ns	3.5 ns

TABLE 3-65: SMX-6144 MODEL RF SPECIFICATIONS

SMX-71XX-XX AND 72XX-XX MW SWITCH

The VTI SMX-71xx-xx and 72xx-xx Series of microwave switch cards extends functionality typically reserved for dedicated stand-alone systems into the PXIe form-factor. Single and dual slot configurations provide the ability to mix and match multiple switch configurations including SPDT, SP4T and SP6T. Embedded virtual schematic control further simplifies setup and debugging allowing all relays to be engaged independent of application software and device drivers.

These switch modules are designed for high-fidelity switching applications up to 67 GHz. Ideally suited for medium-to-high density automated test equipment (ATE), the SMX-71xx-xx/72xx-xx Series deliver uncompromised measurement integrity ideal for the most demanding aerospace, defense and communication applications.

Below Table gives the details of different models of SMX-71xx-xx/72xx-xx;

Model	P/N	Configuration
SPDT		
SMX-7121-18	70-0409-509R	SINGLE PXIe SLOT WITH (1) SPDT 18GHZ MW SWITCH
SMX-7122-18	70-0409-510R	SINGLE PXIe SLOT WITH (2) SPDT 18GHZ MW SWITCH
SMX-7223-18	70-0409-533R	DUAL PXIe SLOT WITH (3) SPDT 18GHZ MW SWITCH
SMX-7224-18	70-0409-534R	DUAL PXIe SLOT WITH (4) SPDT 18GHZ MW SWITCH
SMX-7121-26	70-0409-517R	SINGLE PXIe SLOT WITH (1) SPDT 26.5GHZ MW SWITCH
SMX-7122-26	70-0409-518R	SINGLE PXIe SLOT WITH (2) SPDT 26.5GHZ MW SWITCH
SMX-7223-26	70-0409-535R	DUAL PXIe SLOT WITH (3) SPDT 26.5GHZ MW SWITCH
SMX-7224-26	70-0409-536R	DUAL PXIe SLOT WITH (4) SPDT 26.5GHZ MW SWITCH
SMX-7121-40	70-0409-525R	SINGLE PXIe SLOT WITH (1) SPDT 40GHZ MW SWITCH
SMX-7122-40	70-0409-526R	SINGLE PXIe SLOT WITH (2) SPDT 40GHZ MW SWITCH
SMX-7223-40	70-0409-537R	DUAL PXIe SLOT WITH (3) SPDT 40GHZ MW SWITCH
SMX-7224-40	70-0409-538R	DUAL PXIe SLOT WITH (4) SPDT 40GHZ MW SWITCH
SMX-7121-50	70-0409-539R	SINGLE PXIe SLOT WITH (1) SPDT 50GHZ MW SWITCH
SMX-7122-50	70-0409-540R	SINGLE PXIe SLOT WITH (2) SPDT 50GHZ MW SWITCH
SMX-7223-50	70-0409-541R	DUAL PXIe SLOT WITH (3) SPDT 50GHZ MW SWITCH
SMX-7224-50	70-0409-542R	DUAL PXIe SLOT WITH (4) SPDT 50GHZ MW SWITCH
SMX-7121-67	70-0409-543R	SINGLE PXIe SLOT WITH (1) SPDT 67GHZ MW SWITCH
SMX-7122-67	70-0409-544R	SINGLE PXIe SLOT WITH (2) SPDT 67GHZ MW SWITCH
SMX-7223-67	70-0409-545R	DUAL PXIe SLOT WITH (3) SPDT 67GHZ MW SWITCH
SMX-7224-67	70-0409-546R	DUAL PXIe SLOT WITH (4) SPDT 67GHZ MW SWITCH

TABLE 3-66: SMX-7x2x-xx SPDT SWITCH MODELS

Model	P/N	Configuration
SP4T		
SMX-7241-06	70-0409-503R	DUAL PXIe SLOT WITH (1) SP4T 6GHZ MW SWITCH
SMX-7242-06	70-0409-504R	DUAL PXIe SLOT WITH (2) SP4T 6GHZ MW SWITCH
SMX-7243-06	70-0409-505R	DUAL PXIe SLOT WITH (3) SP4T 6GHZ MW SWITCH
SMX-7241-26	70-0409-519R	DUAL PXIe SLOT WITH (1) SP4T 26.5GHZ MW SWITCH
SMX-7242-26	70-0409-520R	DUAL PXIe SLOT WITH (2) SP4T 26.5GHZ MW SWITCH
SMX-7243-26	70-0409-521R	DUAL PXIe SLOT WITH (3) SP4T 26.5GHZ MW SWITCH
SMX-7241-40	70-0409-527R	DUAL PXIe SLOT WITH (1) SP4T 40GHZ MW SWITCH
SMX-7242-40	70-0409-528R	DUAL PXIe SLOT WITH (2) SP4T 40GHZ MW SWITCH
SMX-7243-40	70-0409-529R	DUAL PXIe SLOT WITH (3) SP4T 40GHZ MW SWITCH
SP6T		
SMX-7261-06	70-0409-506R	DUAL PXIe SLOT WITH (1) SP6T 6GHZ MW SWITCH
SMX-7262-06	70-0409-507R	DUAL PXIe SLOT WITH (2) SP6T 6GHZ MW SWITCH
SMX-7263-06	70-0409-508R	DUAL PXIe SLOT WITH (3) SP6T 6GHZ MW SWITCH
SMX-7261-26	70-0409-522R	DUAL PXIe SLOT WITH (1) SP6T 26.5GHZ MW SWITCH
SMX-7262-26	70-0409-523R	DUAL PXIe SLOT WITH (2) SP6T 26.5GHZ MW SWITCH
SMX-7263-26	70-0409-524R	DUAL PXIe SLOT WITH (3) SP6T 26.5GHZ MW SWITCH
SMX-7261-40	70-0409-530R	DUAL PXIe SLOT WITH (1) SP6T 40GHZ MW SWITCH
SMX-7262-40	70-0409-531R	DUAL PXIe SLOT WITH (2) SP6T 40GHZ MW SWITCH
SMX-7263-40	70-0409-532R	DUAL PXIe SLOT WITH (3) SP6T 40GHZ MW SWITCH
TRANSFER SW		
SMX-72T1-26	70-0409-551R	DUAL PXIe SLOT WITH (1) 26.5GHZ TRANSFER SWITCH
SMX-72T2-26	70-0409-552R	DUAL PXIe SLOT WITH (2) 26.5GHZ TRANSFER SWITCH
SMX-72T1-40	70-0409-554R	DUAL PXIe SLOT WITH (1) 40GHZ TRANSFER SWITCH
SMX-72T2-40	70-0409-555R	DUAL PXIe SLOT WITH (2) 40GHZ TRANSFER SWITCH
SMX-72T1-50	70-0409-557R	DUAL PXIe SLOT WITH (1) 50GHZ TRANSFER SWITCH
SMX-72T2-50	70-0409-558R	DUAL PXIe SLOT WITH (2) 50GHZ TRANSFER SWITCH

TABLE 3-67: SMX-7x4x-xx/7x6x-xx/7xTx-xx SP4T/SP6T/TRANSFERSWITCH MODELS

SMX-712x-xx 722x-xx SPDT MW SW SPECIFICATIONS

	SMX-7121-18	SMX-7122-18	SMX-7223-18	SMX-7224-18	SMX-7121-26	SMX-7122-26	SMX-7223-26	SMX-7224-26
CONFIGURATION	(1) SPDT	(2) SPDT	(3) SPDT	(4) SPDT	(1) SPDT	(2) SPDT	(3) SPDT	(4) SPDT
FREQUENCY RANGE	18 GHz	18 GHz	18 GHz	18 GHz	26.5 GHz	26.5 GHz	26.5 GHz	26.5 GHz
PXIe SLOT	Single	Single	Dual	Dual	Single	Single	Dual	Dual
CONNECTOR TYPE	SMA							
RELAY TYPE	Electromechanical							
SWITCHING TIME	< 10 ms							
SWITCH OPERATIONS	10000000							
IMPEDANCE	50 Ohms							
AVG POWER PER CHANNEL (at 25 Deg C)								
DC-3 GHz	240W	240W	240W	240W	240W	240W	240W	240W
3-8 GHz	150 W	150 W	150 W	150 W	150 W	150 W	150 W	150 W
8-12.4 GHz	120W	120W	120W	120W	120W	120W	120W	120W
12.4-18 GHz	100W	100W	100W	100W	100W	100W	100W	100W
18-26.5 GHz	-	-	-	-	40W	40W	40W	40W
INSERTION LOSS (MAX)								
DC - 3GHz (dB)	0.2	0.2	0.2	0.2	0.2	0.2	0.2	0.2
3GHz - 6GHz (dB)	0.3	0.3	0.3	0.3	0.3	0.3	0.3	0.3
6GHz - 8GHz (dB)	0.3	0.3	0.3	0.3	0.3	0.3	0.3	0.3
8GHz - 12.4GHz (dB)	0.4	0.4	0.4	0.4	0.4	0.4	0.4	0.4
12.4GHz - 18GHz (dB)	0.5	0.5	0.5	0.5	0.5	0.5	0.5	0.5
18GHz - 26.5GHz (dB)	-	-	-	-	0.7	0.7	0.7	0.7
ISOLATION (MIN)								
DC - 3GHz (dB)	80	80	80	80	80	80	80	80
3GHz - 6GHz (dB)	70	70	70	70	70	70	70	70
6GHz - 8GHz (dB)	70	70	70	70	70	70	70	70
8GHz - 12.4GHz (dB)	60	60	60	60	60	60	60	60
12.4GHz - 18GHz (dB)	60	60	60	60	60	60	60	60
18GHz - 26.5GHz (dB)	-	-	-	-	55	55	55	55
VSWR (MAX)								
DC - 3GHz (dB)	1.2:1	1.2:1	1.2:1	1.2:1	1.2:1	1.2:1	1.2:1	1.2:1
3GHz - 6GHz (dB)	1.3:1	1.3:1	1.3:1	1.3:1	1.3:1	1.3:1	1.3:1	1.3:1
6GHz - 8GHz (dB)	1.3:1	1.3:1	1.3:1	1.3:1	1.3:1	1.3:1	1.3:1	1.3:1
8GHz - 12.4GHz (dB)	1.4:1	1.4:1	1.4:1	1.4:1	1.4:1	1.4:1	1.4:1	1.4:1
12.4GHz - 18GHz (dB)	1.5:1	1.5:1	1.5:1	1.5:1	1.5:1	1.5:1	1.5:1	1.5:1
18GHz - 26.5GHz (dB)	-	-	-	-	1.7:1	1.7:1	1.7:1	1.7:1

TABLE 3-55: SMX-7x2x-xx SPDT SW SPECIFICATIONS

	SMX-7121-40	SMX-7122-40	SMX-7223-40	SMX-7224-40	SMX-7121-50	SMX-7122-50	SMX-7223-50	SMX-7224-50
CONFIGURATION	(1) SPDT	(2) SPDT	(3) SPDT	(4) SPDT	(1) SPDT	(2) SPDT	(3) SPDT	(4) SPDT
FREQUENCY RANGE	40 GHz	40 GHz	40 GHz	40 GHz	50 GHz	50 GHz	50 GHz	50 GHz
PXIe SLOT	Single	Single	Dual	Dual	Single	Single	Dual	Dual
CONNECTOR TYPE	SMA 2.9				2.4mm female			
RELAY TYPE	Electromechanical							
SWITCHING TIME	< 10 ms							
SWITCH OPERATIONS	10000000				2 million			
IMPEDANCE	50 Ohms							
AVG POWER PER CHANNEL (at 25 Deg C)								
DC-6 GHz	80W	80W	80W	80W	80W	80W	80W	80W
6-12.4 GHz	60 W	60 W	60 W	60 W	60 W	60 W	60 W	60 W
12.4-18 GHz	50W	50W	50W	50W	50W	50W	50W	50W
18-26.5 GHz	20W	20W	20W	20W	20W	20W	20W	20W
26.5-40 GHz	10W	10W	10W	10W	10W	10W	10W	10W
40-50GHz	-	-	-	-	5W	5W	5W	5W
INSERTION LOSS (MAX)								
DC - 6GHz (dB)	0.3	0.3	0.3	0.3	0.3	0.3	0.3	0.3
6GHz - 8GHz (dB)	0.4	0.4	0.4	0.4	0.4	0.4	0.4	0.4
8GHz - 12.4GHz (dB)	0.4	0.4	0.4	0.4	0.4	0.4	0.4	0.4
12.4GHz - 18GHz (dB)	0.5	0.5	0.5	0.5	0.5	0.5	0.5	0.5
18GHz - 26.5GHz (dB)	0.7	0.7	0.7	0.7	0.7	0.7	0.7	0.7
26.5GHz - 40GHz (dB)	0.8	0.8	0.8	0.8	0.8	0.8	0.8	0.8
40GHz - 50GHz (dB)	-	-	-	-	1.1	1.1	1.1	1.1
ISOLATION (MIN)								
DC - 6GHz (dB)	70	70	70	70	70	70	70	70
6GHz - 8GHz (dB)	60	60	60	60	60	60	60	60
8GHz - 12.4GHz (dB)	60	60	60	60	60	60	60	60
12.4GHz - 18GHz (dB)	60	60	60	60	60	60	60	60
18GHz - 26.5GHz (dB)	55	55	55	55	55	55	55	55
26.5GHz - 40GHz (dB)	50	50	50	50	50	50	50	50
40GHz - 50GHz (dB)	-	-	-	-	50	50	50	50
VSWR (MAX)								
DC - 6GHz (dB)	1.3:1	1.3:1	1.3:1	1.3:1	1.3:1	1.3:1	1.3:1	1.3:1
6GHz - 8GHz (dB)	1.4:1	1.4:1	1.4:1	1.4:1	1.4:1	1.4:1	1.4:1	1.4:1
8GHz - 12.4GHz (dB)	1.4:1	1.4:1	1.4:1	1.4:1	1.4:1	1.4:1	1.4:1	1.4:1
12.4GHz - 18GHz (dB)	1.5:1	1.5:1	1.5:1	1.5:1	1.5:1	1.5:1	1.5:1	1.5:1
18GHz - 26.5GHz (dB)	1.7:1	1.7:1	1.7:1	1.7:1	1.7:1	1.7:1	1.7:1	1.7:1
26.5GHz - 40GHz (dB)	1.9:0	1.9:0	1.9:0	1.9:0	1.9:0	1.9:0	1.9:0	1.9:0
40GHz - 50GHz (dB)	-	-	-	-	1.9:0	1.9:0	1.9:0	1.9:0

TABLE 3-68: SMX-7x2x-XX SPDT SW SPECIFICATIONS

	SMX-7121-67	SMX-7122-67	SMX-7223-67	SMX-7224-67
CONFIGURATION	(1) SPDT	(2) SPDT	(3) SPDT	(4) SPDT
FREQUENCY RANGE	67 GHz	67 GHz	67 GHz	67 GHz
PXIe SLOT	Single	Single	Dual	Dual
CONNECTOR TYPE	1.85mm female			
RELAY TYPE	Electromechanical			
SWITCHING TIME	< 10 ms			
SWITCH OPERATIONS	2 million			
IMPEDANCE	50 Ohms			
AVG POWER PER CHANNEL (at 25 Deg C)				
DC-6 GHz	80W	80W	80W	80W
6-12.4 GHz	60 W	60 W	60 W	60 W
12.4-18 GHz	50W	50W	50W	50W
18-26.5 GHz	20W	20W	20W	20W
26.5-40 GHz	10W	10W	10W	10W
40-50GHz	5W	5W	5W	5W
50-67GHz	3W	3W	3W	3W
INSERTION LOSS (MAX)				
DC - 6GHz (dB)	0.3	0.3	0.3	0.3
6GHz - 12.4GHz (dB)	0.4	0.4	0.4	0.4
12.4GHz - 18GHz (dB)	0.5	0.5	0.5	0.5
18GHz - 26.5GHz (dB)	0.7	0.7	0.7	0.7
26.5GHz - 40GHz (dB)	0.8	0.8	0.8	0.8
40GHz - 50GHz (dB)	1.1	1.1	1.1	1.1
50GHz - 67GHz (dB)	1.1	1.1	1.1	1.1
ISOLATION (MIN)				
DC - 6GHz (dB)	70	70	70	70
6GHz - 12.4GHz (dB)	60	60	60	60
12.4GHz - 18GHz (dB)	60	60	60	60
18GHz - 26.5GHz (dB)	55	55	55	55
26.5GHz - 40GHz (dB)	50	50	50	50
40GHz - 50GHz (dB)	50	50	50	50
50GHz - 67GHz (dB)	50	50	50	50
VSWR (MAX)				
DC - 6GHz (dB)	1.3:1	1.3:1	1.3:1	1.3:1
6GHz - 12.4GHz (dB)	1.4:1	1.4:1	1.4:1	1.4:1
12.4GHz - 18GHz (dB)	1.5:1	1.5:1	1.5:1	1.5:1
18GHz - 26.5GHz (dB)	1.7:1	1.7:1	1.7:1	1.7:1
26.5GHz - 40GHz (dB)	1.9:0	1.9:0	1.9:0	1.9:0
40GHz - 50GHz (dB)	1.9:0	1.9:0	1.9:0	1.9:0
50GHz - 67GHz (dB)	1.9:0	1.9:0	1.9:0	1.9:0

TABLE 3-57: SMX-7x2x-xx SPDT SPECIFICATIONS

SMX-7x4x-xx / 7x6x-xx SP4T/SP6T MW SW SPECIFICATIONS

	SMX-7241-06	SMX-7242-06	SMX-7243-06	SMX-7261-06	SMX-7262-06	SMX-7263-06
CONFIGURATION	(1) SP4T	(2) SP4T	(3) SP4T	(1) SP6T	(2) SP6T	(3) SP6T
FREQUENCY RANGE	6 GHz					
PXIe SLOT	Dual					
CONNECTOR TYPE	SMA					
RELAY TYPE	Electromechanical, Coaxial, Normally Open					
SWITCHING TIME	< 10 ms					
SWITCH OPERATIONS	10000000					
IMPEDANCE	50 Ohms					
AVG POWER PER CHANNEL (at 25 Deg C)						
DC-3 GHz	250W					
3-6 GHz	170 W					
INSERTION LOSS (MAX)						
DC-3 GHz (dB)	0.2					
3-6 GHz (dB)	0.3					
ISOLATION (MIN)						
DC-3 GHz (dB)	80					
3-6 GHz (dB)	70					
VSWR (MAX)						
DC-3 GHz (dB)	1.2:1					
3-6 GHz (dB)	1.3:1					

TABLE 3-58: SMX-7x4x-xx/7x6x-xx SP4T/SP6T SPECIFICATIONS

	SMX-7241-26	SMX-7242-26	SMX-7243-26	SMX-7261-26	SMX-7262-26	SMX-7263-26
CONFIGURATION	(1) SP4T	(2) SP4T	(3) SP4T	(1) SP6T	(2) SP6T	(3) SP6T
FREQUENCY RANGE	26.5 GHz					
PXIe SLOT	Dual					
CONNECTOR TYPE	SMA					
RELAY TYPE	Electromechanical, Coaxial, Normally Open					
SWITCHING TIME	< 10 ms					
SWITCH OPERATIONS	10000000					
IMPEDANCE	50 Ohms					
AVG POWER PER CHANNEL (at 25 Deg C)						
DC-3 GHz	250W					
3-8 GHz	150 W					
8-12.4 GHz	120 W					
12.4-18 GHz	100 W					
18-26.5 GHz	40 W					
INSERTION LOSS (MAX)						
DC-3 GHz	0.2					
3-8 GHz	0.3					
8-12.4 GHz	0.4					
12.4-18 GHz	0.5					
18-26.5 GHz	0.6					
ISOLATION (MIN)						
DC-3 GHz	80					
3-8 GHz	70					
8-12.4 GHz	60					
12.4-18 GHz	60					
18-26.5 GHz	55					
VSWR (MAX)						
DC-3 GHz	1.2:1					
3-8 GHz	1.3:1					
8-12.4 GHz	1.4:1					
12.4-18 GHz	1.5:1					
18-26.5 GHz	1.6:1					

TABLE 3-59: SMX-7x4x-xx/7x6x-xx SP4T/SP6T SPECIFICATIONS

	SMX-7241-40	SMX-7242-40	SMX-7243-40	SMX-7261-40	SMX-7262-40	SMX-7263-40
CONFIGURATION	(1) SP4T	(2) SP4T	(3) SP4T	(1) SP6T	(2) SP6T	(3) SP6T
FREQUENCY RANGE	40 GHz					
PXIe SLOT	Dual					
CONNECTOR TYPE	SMA 2.9					
RELAY TYPE	Electromechanical, Coaxial, Normally Open					
SWITCHING TIME	< 10 ms					
SWITCH OPERATIONS	2000000					
IMPEDANCE	50 Ohms					
AVG POWER PER CHANNEL (at 25 Deg C)						
DC-3 GHz	60W					
3-8 GHz	35 W					
8-12.4 GHz	30 W					
12.4-18 GHz	25 W					
18-26.5 GHz	15 W					
26.5-40 GHz	5 W					
INSERTION LOSS (MAX)						
DC-3 GHz	0.2					
3-8 GHz	0.3					
8-12.4 GHz	0.4					
12.4-18 GHz	0.5					
18-26.5 GHz	0.7					
26.5-40 GHz	1.1					
ISOLATION (MIN)						
DC-3 GHz	80					
3-8 GHz	70					
8-12.4 GHz	60					
12.4-18 GHz	60					
18-26.5 GHz	55					
26.5-40 GHz	45					
VSWR (MAX)						
DC-3 GHz	1.2:1					
3-8 GHz	1.3:1					
8-12.4 GHz	1.4:1					
12.4-18 GHz	1.5:1					
18-26.5 GHz	1.7:1					
26.5-40 GHz	2.2:1					

TABLE 3-60: SMX-7x4x-xx/7x6x-xx SP4T/SP6T SPECIFICATIONS

	SMX-72T1-26	SMX-72T2-26	SMX-72T1-40	SMX-72T2-40	SMX-72T1-50	SMX-72T2-50
CONFIGURATION	(1) TRANSFER	(2) TRANSFER	(1) TRANSFER	(2) TRANSFER	(1) TRANSFER	(2) TRANSFER
FREQUENCY RANGE	26.5 GHz	26.5 GHz	40 GHz	40 GHz	50 GHz	50 GHz
PXIe SLOT	Dual					
CONNECTOR TYPE	SMA Female					
RELAY TYPE	Electromechanical					
SWITCHING TIME	< 15 ms					
SWITCH OPERATIONS	2500000					
IMPEDANCE	50 Ohms					
AVG POWER PER CHANNEL (at 25 Deg C)						
DC-6 GHz	80W	80W	80W	80W	80W	80W
6-12.4 GHz	60 W	60 W	60 W	60 W	60 W	60 W
12.4-18 GHz	50W	50W	50W	50W	50W	50W
18-26.5 GHz	20W	20W	20W	20W	20W	20W
26.5-40 GHz	-	-	10W	10W	10W	10W
40-50GHz	-	-	-	-	5W	5W
INSERTION LOSS (MAX)						
DC-6 GHz	0.3	0.3	0.3	0.3	0.3	0.3
6-12.4 GHz	0.4	0.4	0.4	0.4	0.4	0.4
12.4-18 GHz	0.5	0.5	0.5	0.5	0.5	0.5
18-26.5 GHz	0.7	0.7	0.7	0.7	0.7	0.7
26.5-40 GHz	-	-	0.8	0.8	0.8	0.8
40-50GHz	-	-	-	-	1.1	1.1
ISOLATION (MIN)						
DC-6 GHz	70	70	70	70	70	70
6-12.4 GHz	60	60	60	60	60	60
12.4-18 GHz	60	60	60	60	60	60
18-26.5 GHz	55	55	55	55	55	55
26.5-40 GHz	-	-	50	50	50	50
40-50GHz	-	-	-	-	50	50
VSWR (MAX)						
DC-6 GHz	1.3:1	1.3:1	1.3:1	1.3:1	1.3:1	1.3:1
6-12.4 GHz	1.4:1	1.4:1	1.4:1	1.4:1	1.4:1	1.4:1
12.4-18 GHz	1.5:1	1.5:1	1.5:1	1.5:1	1.5:1	1.5:1
18-26.5 GHz	1.7:1	1.7:1	1.7:1	1.7:1	1.7:1	1.7:1
26.5-40 GHz	-	-	1.9:1	1.9:1	1.9:1	1.9:1
40-50GHz	-	-	-	-	2:00	2:00

TABLE 3-61: SMX-72Tx-xx TRANSFERSW SPECIFICATIONS

SPDT MICROWAVE SWITCHES

SMX-7121-18: SINGLE SLOT MW SW CARD WITH ONE 18 GHz SPDT SWITCH

The SMX-7121-18 switch module is a single slot microwave switch card with one 18 GHz SPDT Switch.

SMX-7122-18: SINGLE SLOT MW SW CARD WITH TWO 18 GHz SPDT SWITCHES

The SMX-7122-18 switch module is a single slot microwave switch card with two 18 GHz SPDT Switches. All relays are independently controllable.

SMX-7223-18: DUAL SLOT MW SW CARD WITH THREE 18 GHz SPDT SWITCHES

The SMX-7223-18 switch module is a dual slot microwave switch card with three 18 GHz SPDT Switches. All relays are independently controllable.

SMX-7224-18: DUAL SLOT MW SW CARD WITH FOUR 18 GHz SPDT SWITCHES

The SMX-7224-18 switch module is a dual slot microwave switch card with four 18 GHz SPDT Switches. All relays are independently controllable.

SMX-7121-26: SINGLE SLOT MW SW CARD WITH ONE 26.5 GHz SPDT SWITCH

The SMX-7121-26 switch module is a single slot microwave switch card with one 26.5 GHz SPDT Switch.

SMX-7122-26: SINGLE SLOT MW SW CARD WITH TWO 26.5 GHz SPDT SWITCHES

The SMX-7122-26 switch module is a single slot microwave switch card with two 26.5 GHz SPDT Switches. All relays are independently controllable.

SMX-7223-26: DUAL SLOT MW SW CARD WITH THREE 26.5 GHz SPDT SWITCHES

The SMX-7223-26 switch module is a dual slot microwave switch card with three 26.5 GHz SPDT Switches. All relays are independently controllable.

SMX-7224-26: DUAL SLOT MW SW CARD WITH FOUR 26.5 GHz SPDT SWITCHES

The SMX-7224-26 switch module is a dual slot microwave switch card with four 26.5 GHz SPDT Switches. All relays are independently controllable.

SMX-7121-40: SINGLE SLOT MW SW CARD WITH ONE 40 GHz SPDT SWITCH

The SMX-7121-40 switch module is a single slot microwave switch card with one 40 GHz SPDT Switch.

SMX-7122-40: SINGLE SLOT MW SW CARD WITH TWO 40 GHz SPDT SWITCHES

The SMX-7122-40 switch module is a single slot microwave switch card with two 40 GHz SPDT Switches. All relays are independently controllable.

SMX-7223-40: DUAL SLOT MW SW CARD WITH THREE 40 GHz SPDT SWITCHES

The SMX-7223-40 switch module is a dual slot microwave switch card with three 40 GHz SPDT Switches. All relays are independently controllable.

SMX-7224-40: DUAL SLOT MW SW CARD WITH FOUR 40 GHz SPDT SWITCHES

The SMX-7224-40 switch module is a dual slot microwave switch card with four 40 GHz SPDT Switches. All relays are independently controllable.

SMX-7121-50: SINGLE SLOT MW SW CARD WITH ONE 50 GHz SPDT SWITCH

The SMX-7121-50 switch module is a single slot microwave switch card with one 50 GHz SPDT Switch.

SMX-7122-50: SINGLE SLOT MW SW CARD WITH TWO 50 GHz SPDT SWITCHES

The SMX-7122-50 switch module is a single slot microwave switch card with two 50 GHz SPDT Switches. All relays are independently controllable.

SMX-7223-50: DUAL SLOT MW SW CARD WITH THREE 50 GHz SPDT SWITCHES

The SMX-7223-50 switch module is a dual slot microwave switch card with three 50 GHz SPDT Switches. All relays are independently controllable.

SMX-7224-50: DUAL SLOT MW SW CARD WITH FOUR 50 GHz SPDT SWITCHES

The SMX-7224-50 switch module is a dual slot microwave switch card with four 50 GHz SPDT Switches. All relays are independently controllable.

SMX-7121-67: SINGLE SLOT MW SW CARD WITH ONE 67 GHz SPDT SWITCH

The SMX-7121-67 switch module is a single slot microwave switch card with one 67 GHz SPDT Switch.

SMX-7122-67: SINGLE SLOT MW SW CARD WITH TWO 67 GHz SPDT SWITCHES

The SMX-7122-67 switch module is a single slot microwave switch card with two 67 GHz SPDT Switches. All relays are independently controllable.

SMX-7223-67: DUAL SLOT MW SW CARD WITH THREE 67 GHz SPDT SWITCHES

The SMX-7223-67 switch module is a dual slot microwave switch card with three 67 GHz SPDT Switches. All relays are independently controllable.

SMX-7224-67: DUAL SLOT MW SW CARD WITH FOUR 67 GHz SPDT SWITCHES

The SMX-7224-67 switch module is a dual slot microwave switch card with four 67 GHz SPDT Switches. All relays are independently controllable.

SP4T MICROWAVE SWITCHES**SMX-7241-06: DUAL SLOT MW SW CARD WITH ONE 06 GHz SP4T SWITCH**

The SMX-7241-06 switch module is a double slot microwave switch card with one 06 GHz SP4T Switch.

SMX-7242-06: DUAL SLOT MW SW CARD WITH TWO 06 GHz SP4T SWITCHES

The SMX-7242-06 switch module is a double slot microwave switch card with two 06 GHz SP4T Switches. All relays are independently controllable.

SMX-7243-06: DUAL SLOT MW SW CARD WITH THREE 06 GHz SP4T SWITCHES

The SMX-7243-06 switch module is a double slot microwave switch card with three 06 GHz SP4T Switches. All relays are independently controllable.

SMX-7241-26: DUAL SLOT MW SW CARD WITH ONE 26.5 GHz SP4T SWITCH

The SMX-7241-26 switch module is a double slot microwave switch card with one 26.5 GHz SP4T Switch.

SMX-7242-26: DUAL SLOT MW SW CARD WITH TWO 26.5 GHz SP4T SWITCHES

The SMX-7242-26 switch module is a double slot microwave switch card with two 26.5 GHz SP4T Switches. All relays are independently controllable.

SMX-7243-26: DUAL SLOT MW SW CARD WITH THREE 26.5 GHz SP4T SWITCHES

The SMX-7243-26 switch module is a double slot microwave switch card with three 26.5 GHz SP4T Switches. All relays are independently controllable.

SMX-7241-40: DUAL SLOT MW SW CARD WITH ONE 40 GHz SP4T SWITCH

The SMX-7241-40 switch module is a double slot microwave switch card with one 40 GHz SP4T Switch.

SMX-7242-40: DUAL SLOT MW SW CARD WITH TWO 40 GHz SP4T SWITCHES

The SMX-7242-40 switch module is a double slot microwave switch card with two 40 GHz SP4T Switches. All relays are independently controllable.

SMX-7243-40: DUAL SLOT MW SW CARD WITH THREE 40 GHz SP4T SWITCHES

The SMX-7243-40 switch module is a double slot microwave switch card with three 40 GHz SP4T Switches. All relays are independently controllable.

SP6T MICROWAVE SWITCHES**SMX-7261-06: DUAL SLOT MW SW CARD WITH ONE 06 GHz SP6T SWITCH**

The SMX-7261-06 switch module is a double slot microwave switch card with one 06 GHz SP6T Switch.

SMX-7262-06: DUAL SLOT MW SW CARD WITH TWO 06 GHz SP6T SWITCHES

The SMX-7262-06 switch module is a double slot microwave switch card with two 06 GHz SP6T Switches. All relays are independently controllable.

SMX-7263-06: DUAL SLOT MW SW CARD WITH THREE 06 GHz SP6T SWITCHES

The SMX-7263-06 switch module is a double slot microwave switch card with three 06 GHz SP6T Switches. All relays are independently controllable.

SMX-7261-26: DUAL SLOT MW SW CARD WITH ONE 26.5 GHz SP6T SWITCH

The SMX-7261-26 switch module is a double slot microwave switch card with one 26.5 GHz SP6T Switch.

SMX-7262-26: DUAL SLOT MW SW CARD WITH TWO 26.5 GHz SP6T SWITCHES

The SMX-7262-26 switch module is a double slot microwave switch card with two 26.5 GHz SP6T Switches. All relays are independently controllable.

SMX-7263-26: DUAL SLOT MW SW CARD WITH THREE 26.5 GHz SP6T SWITCHES

The SMX-7263-26 switch module is a double slot microwave switch card with three 26.5 GHz SP6T Switches. All relays are independently controllable.

SMX-7261-40: DUAL SLOT MW SW CARD WITH ONE 40 GHz SP6T SWITCH

The SMX-7261-40 switch module is a double slot microwave switch card with one 40 GHz SP6T Switch.

SMX-7262-40: DUAL SLOT MW SW CARD WITH TWO 40 GHz SP6T SWITCHES

The SMX-7262-40 switch module is a double slot microwave switch card with two 40 GHz SP6T Switches. All relays are independently controllable.

SMX-7263-40: DUAL SLOT MW SW CARD WITH THREE 40 GHz SP6T SWITCHES

The SMX-7263-40 switch module is a double slot microwave switch card with three 40 GHz SP6T Switches. All relays are independently controllable.

TRANSFER MICROWAVE SWITCHES**SMX-72T1-26: DUAL SLOT MW SW CARD WITH ONE 26.5 GHz TRANSFER SWITCH**

The SMX-72T1-26 switch module is a double slot microwave switch card with one 26.5 GHz TRANSFER Switch.

SMX-72T2-26: DUAL SLOT MW SW CARD WITH TWO 26.5 GHz TRANSFER SWITCH

The SMX-72T2-26 switch module is a double slot microwave switch card with two 26.5 GHz TRANSFER Switches. All relays are independently controllable.

SMX-72T1-40: DUAL SLOT MW SW CARD WITH ONE 40 GHz TRANSFER SWITCH

The SMX-72T1-40 switch module is a double slot microwave switch card with one 40 GHz TRANSFER Switch.

SMX-72T2-40: DUAL SLOT MW SW CARD WITH TWO 40 GHz TRANSFER SWITCH

The SMX-72T2-40 switch module is a double slot microwave switch card with two 40 GHz TRANSFER Switches. All relays are independently controllable.

SMX-72T1-50: DUAL SLOT MW SW CARD WITH ONE 50 GHz TRANSFER SWITCH

The SMX-72T1-50 switch module is a double slot microwave switch card with one 50 GHz TRANSFER Switch.

SMX-72T2-50: DUAL SLOT MW SW CARD WITH TWO 50 GHz TRANSFER SWITCH

The SMX-72T2-50 switch module is a double slot microwave switch card with two 50 GHz TRANSFER Switches. All relays are independently controllable.

Front Panel configurations

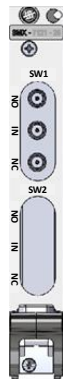

Slot Width : Single PXIe slot
Model : SMX-7121-xx

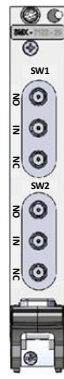

Slot Width : Single PXIe slot
Model : SMX-7122-xx

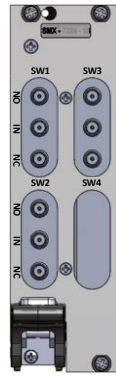

Slot Width : Dual PXIe slot
Model : SMX-7223-xx

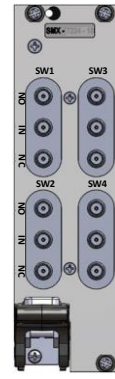

Slot Width : Dual PXIe slot
Model : SMX-7224-xx



Slot Width : Dual PXIe slot
Model : SMX-7241-xx,
SMX-7261-xx

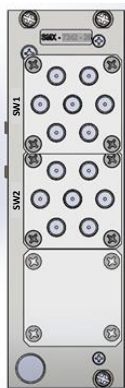

Slot Width : Dual PXIe slot
Model : SMX-7242-xx,
SMX-7262-xx

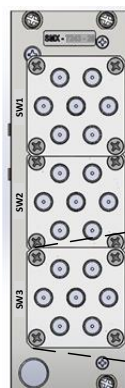

Slot Width : Dual PXIe slot
Model : SMX-7243-xx,
SMX-7263-xx

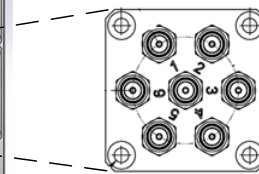

Note : For SP4T port 3 & 6 are not connected. For SP6T all the 6 ports are connected.

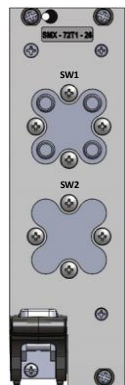

Slot Width : Dual PXIe slot
Model : SMX-72T1-xx

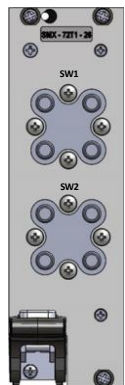

Slot Width : Dual PXIe slot
Model : SMX-72T2-xx

FIGURE 3-118: FRONT PANEL CONFIGURATIONS OF SMX-71xx-xx/72xx-xx

Note : -xx indicates the Frequency range of the card.

APPENDIX A

MAXIMUM NUMBER OF RELAYS OPERATION PER CARD

Due to the Backplane power limitation, the percentage of Relays which can be simultaneously switched per slot is as per the below table,

NOTE SMX-61xx models without SMB in model name are SMX-61xx models with PkZ connector

SMX Models	Percentage of Relays which can be simultaneously switched per slot
SMX-2002	100%
SMX-3001, SMX-3002, SMX-3003, SMX-3004, SMX-3005, SMX-3006, SMX-3007 SMX-3001DS, SMX-3002DS, SMX-3003DS, SMX-3004DS, SMX-3005DS, SMX-3006DS, SMX-3007DS	100%
SMX-3276, SMX-3277, SMX-3278, SMX-3279, SMX-3280, SMX-3276DS, SMX-3277DS, SMX-3278DS, SMX-3279DS, SMX-3280DS,	100%
SMX-4410, SMX-4411, SMX-4412, SMX-4413, SMX-4414, SMX-4415	70%
SMX-5001	100%
SMX-5002, SMX-5004	100%
SMX-6101 SMB, SMX-6103 SMB, SMX-6105 SMB, SMX-6106 SMB, SMX-6111 SMB, SMX-6115 SMB, SMX-6116 SMB, SMX-6144 SMB SMX-6101, SMX-6103, SMX-6105, SMX-6106, SMX-6111, SMX-6115, SMX-6116, SMX-6144	100%
SMX-7121-18, SMX-7122-18, SMX-7223-18, SMX-7224-18, SMX-7121-26, SMX-7122-26, SMX-7223-26, SMX-7224-26, SMX-7121-40, SMX-7122-40, SMX-7223-40, SMX-7224-40, SMX-7121-50, SMX-7122-50, SMX-7223-50, SMX-7224-50, SMX-7121-67, SMX-7122-67, SMX-7223-67, SMX-7224-67	100%
SMX-7241-06, SMX-7242-06, SMX-7243-06, SMX-7261-06, SMX-7262-06, SMX-7263-06, SMX-7241-26, SMX-7242-26, SMX-7243-26, SMX-7261-26, SMX-7262-26, SMX-7263-26, SMX-7241-40, SMX-7242-40, SMX-7243-40, SMX-7261-40, SMX-7262-40, SMX-7263-40,	100%
SMX-72T1-26, SMX-72T2-26, SMX-72T1-40, SMX-72T2-40, SMX-72T1-50, SMX-72T2-50	100%

APPENDIX B

SWITCH CARD ACCESSORIES

LIST OF ACCESSORIES

The following tables provide mating connector, strain relief, crimp pin, and other related accessories for the connectors used with the SMX series switch cards.

160- PIN CONNECTOR (SMX-300X)

These accessories should be used with the SMX-3001, SMX-3001DS, SMX-3002, SMX-3002DS, SMX-3003, SMX-3003DS, SMX-3004, SMX-3004DS, SMX-3005, SMX-3005DS, SMX-3006 and SMX-3007.

CONNECTOR KIT

Description	Connector kit (F/A, SMX-300X-TB160-3, 160-160P#3)
VTI Part Number	70-0367-207R
Connector Kit Includes	43-0218-058R (SMX-300X Label, Pin Details) 52-0791-313R (Cable Assembly SMX-300x-TB160-3, DIFF) 41-0528-010R (Bracket, Strain Relief, 160 PIN Connector)

160- PIN CONNECTOR (SMX-327X)

These accessories should be used with the SMX-3276, SMX-3277, SMX-3278, SMX-3279

CONNECTOR KIT

Description	Connector kit (F/A, SMX-327X TB160-1, 160-160P#1)
VTI Part Number	70-0367-206R
Connector Kit Includes	43-0218-057R (SMX-327X Label, Pin Details) 52-0791-312R (Cable Assembly SMX-327x-TB160-1, DIFF) 41-0528-010R (Bracket, Strain Relief, 160 PIN Connector)

160- PIN CONNECTOR (SMX-5001/SMX-5002)

These accessories should be used with the SMX-5001, SMX-5002

CONNECTOR KIT

Description	Connector kit (F/A, SMX, TB160SE, 160-160P)
VTI Part Number	70-0367-205R
Connector Kit Includes	43-0218-055R (SMX-5001 Label, Pin Details, TB160SE) 43-0218-056R (SMX-5002 Label, Pin Details, TB160SE) 52-0811-130R (Cable Assembly SMX TB160-SE) 41-0528-010R (Bracket, Strain Relief, 160 PIN Connector)

50- PIN CONNECTOR (SMX-5004)

These accessories should be used with the SMX-5004

CONNECTOR KIT	
Description	50 Pin Connector kit
VTI Part Number	52-0195-000
Connector Kit Includes	Two 50-pin connector, two backshells, and 104 crimp pins
CRIMP TOOL	
Description	Crimp tool
VTI Part Number	46-0024-000
Manufacturer/Part Number	Positronic / 9507
INSERTION TOOL	
Description	Tool, contact insertion
VTI Part Number	46-0037-000
Manufacturer/Part Number	Positronic / 9099-1
EXTRACTION TOOL	
Description	Tool, pin extractor
VTI Part Number	46-0036-000
Manufacturer/Part Number	Positronic / 9081-1
TURRET HEAD POSITIONER TOOL	
Description	Tool, Turret Head Positioner
VTI Part Number	46-0025-000
Manufacturer/Part Number	Positronic / 9502-12

41-PIN CONNECTOR(UNTERMINATED) (SMX-200X-XX)

These accessories should be used with the SMX-2002, SMX-200X-XX.

ACCESSORIES	
CONNECTOR KIT	
Description	Connector kit (includes 1 each connector and backshell plus 44 pins)
VTI Part Number	70-0190-001R
CONNECTOR INFORMATION	
Description	Connector, power, female with backshell, insulated, 41 PLC
VTI Part Number	27-0087-041
Manufacturer/Part Number	Positronics GMCT41F0E100J0
CRIMP PIN	
Description	Contact, female, crimp, power connector, 14 - 16 GA (Order qty: 44 per board)
VTI Part Number	27-0087-000
Manufacturer/Part Number	Positronics FC114N2/AA
CRIMP TOOL INFORMATION	
Description	Crimp tool and turret head
VTI Part Number	46-0012-000
Manufacturer/Part Number	Positronics 9501 and 9502-1
INSERTION TOOL	
Description	Tool, contact insertion, size 16 contact, AMP M series
VTI Part Number	46-0014-000
EXTRACTION TOOL	
Description	Tool, pin extractor, power/coaxial
VTI Part Number	46-0015-000
UNTERMINATED CABLE ASSEMBLY	
Description	41-pin, unterminated cable assembly, 3 ft
VTI Part Number	70-0363-506R
BRACKET, STRAIN RELIEF, 41 PINS	
Description	Bracket, Strain Relief, 41 Pins Series M
VTI Part Number	41-0513-000R

160-PIN CONNECTOR (UNTERMINATED)

ACCESSORIES	
STRAIN RELIEF BRACKET KIT (WITHOUT CONNECTOR)	
VTI Part Number	70-0409-160R
CRIMP PIN	
VTI Part Number	52-0109-000R (includes 100 crimp pins)
Manufacturer/Part Number	ERNI 234064
MATING CONNECTOR	
VTI Part Number	27-0088-160 (one per board)
Manufacturer/Part Number	ERNI 024070
CRIMP TOOL (DIN)	
VTI Part Number	46-0010-000
Manufacturer/Part Number	ERNI 014374
EXTRACTION TOOL (DIN)	
VTI Part Number	46-0011-000
Manufacturer/Part Number	ERNI 471555
BRACKET, STRAIN RELIEF, 41 PINS	
Description	Bracket, Strain Relief, 160P/DIN Connector
VTI Part Number	41-0528-010R
UNTERMINATED CABLE ASSEMBLY	
Description	160-pin, unterminated cable assembly, 3 ft
VTI Part Number	70-0363-550R

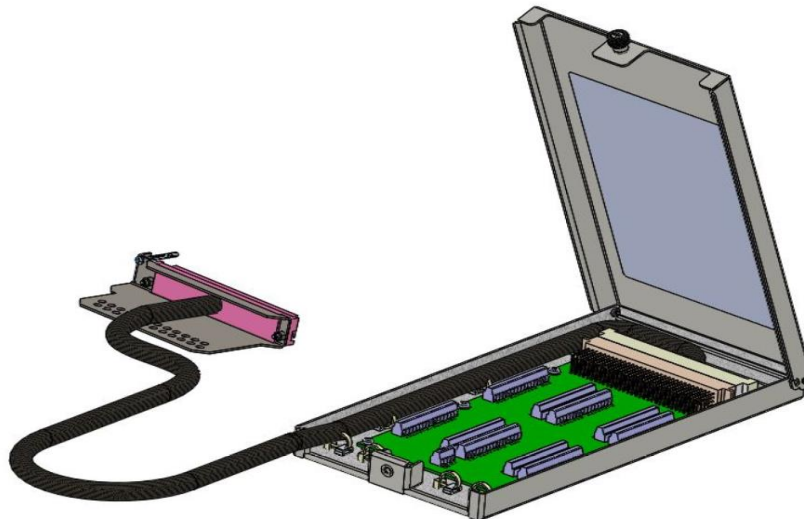

Figure 3-119: BOB-160 PINS

NOTE LABEL Sheet (43-level) part of the accessories shipped as per the ordered SMX model which need to be pasted on the Break-Out-Box.

PkZ MATING CABLES AND HOUSING (SMX-61xx)

These accessories should be used with the SMX-61xx PkZ cards.

Accessories	
PkZ Connector Housing for cables Ø.040-Ø.054	
Description	Housing, 53 position, PkZ plug, w/ 2 strain relief, for cables Ø.040-Ø.054
VTI Part Number	27-0970-000
Manufacturer/Part Number	PHOENIX PRC532DX1XANONE
PkZ Connector Housing for cables Ø.061-Ø.102	
Description	Housing, 53 position, PkZ plug, w/ 2 strain relief, for cables Ø.061-Ø.102
VTI Part Number	27-0970-001
Manufacturer/Part Number	PHOENIX PRC532DX2XANONE
PkZ to SMB, 1.37mm Cable Assembly	
1. Description	Cable Assy, PkZ plug to SMB plug, 1.37mm cable, 6 Inch
VTI Part Number	56-0900-000
Manufacturer/Part Number	PHOENIX 15609DY0003-060
2. Description	Cable Assy, PkZ plug to SMB plug, 1.37mm cable, 12 Inch
VTI Part Number	56-0900-001
Manufacturer/Part Number	PHOENIX 15609DY0003-120
3. Description	Cable Assy, PkZ plug to SMB plug, 1.37mm cable, 24 Inch
VTI Part Number	56-0900-002
Manufacturer/Part Number	PHOENIX 15609DY0003-240
4. Description	Cable Assy, PkZ plug to SMB plug, 1.37mm cable, 36 Inch
VTI Part Number	56-0900-003
Manufacturer/Part Number	PHOENIX 15609DY0003-360
5. Description	Cable Assy, PkZ plug to SMB plug, 1.37mm cable, 48 Inch
VTI Part Number	56-0900-004
Manufacturer/Part Number	PHOENIX 15609DY0003-480
6. Description	Cable Assy, PkZ plug to SMB plug, 1.37mm cable, 60 Inch
VTI Part Number	56-0900-005
Manufacturer/Part Number	PHOENIX 15609DY0003-600
7. Description	Cable Assy, PkZ plug to SMB plug, 1.37mm cable, 96 Inch
VTI Part Number	56-0900-006
Manufacturer/Part Number	PHOENIX 15609DY0003-960
PkZ to SMB, RG178 Cable Assembly	
1. Description	Cable Assy, PkZ plug to SMB plug, RG178 cable, 6 Inch
VTI Part Number	56-0901-000
Manufacturer/Part Number	PHOENIX 15609230092-060
2. Description	Cable Assy, PkZ plug to SMB plug, RG178 cable, 12 Inch
VTI Part Number	56-0901-001
Manufacturer/Part Number	PHOENIX 15609230092-120
3. Description	Cable Assy, PkZ plug to SMB plug, RG178 cable, 24 Inch
VTI Part Number	56-0901-002
Manufacturer/Part Number	PHOENIX 15609230092-240
4. Description	Cable Assy, PkZ plug to SMB plug, RG178 cable, 36 Inch
VTI Part Number	56-0901-003
Manufacturer/Part Number	PHOENIX 15609230092-360
5. Description	Cable Assy, PkZ plug to SMB plug, RG178 cable, 48 Inch
VTI Part Number	56-0901-004
Manufacturer/Part Number	PHOENIX 15609230092-480
6. Description	Cable Assy, PkZ plug to SMB plug, RG178 cable, 60 Inch
VTI Part Number	56-0901-005
Manufacturer/Part Number	PHOENIX 15609230092-600
7. Description	Cable Assy, PkZ plug to SMB plug, RG178 cable, 96 Inch
VTI Part Number	56-0901-006
Manufacturer/Part Number	PHOENIX 15609230092-960
PkZ to SMA, 1.37mm Cable Assembly	
1. Description	Cable Assy, PkZ plug to SMA plug, 1.37mm cable, 6 Inch
VTI Part Number	56-0902-000
Manufacturer/Part Number	PHOENIX 15620DY0004-060
2. Description	Cable Assy, PkZ plug to SMA plug, 1.37mm cable, 12 Inch
VTI Part Number	56-0902-001
Manufacturer/Part Number	PHOENIX 15620DY0004-120
3. Description	Cable Assy, PkZ plug to SMA plug, 1.37mm cable, 24 Inch
VTI Part Number	56-0902-002
Manufacturer/Part Number	PHOENIX 15620DY0004-240
4. Description	Cable Assy, PkZ plug to SMA plug, 1.37mm cable, 36 Inch
VTI Part Number	56-0902-003

Manufacturer/Part Number	PHOENIX 15620DY0004-360
5. Description	Cable Assy, PkZ plug to SMA plug, 1.37mm cable, 48 Inch
VTI Part Number	56-0902-004
Manufacturer/Part Number	PHOENIX 15620DY0004-480
6. Description	Cable Assy, PkZ plug to SMA plug, 1.37mm cable, 60 Inch
VTI Part Number	56-0902-005
Manufacturer/Part Number	PHOENIX 15620DY0004-600
7. Description	Cable Assy, PkZ plug to SMA plug, 1.37mm cable, 96 Inch
VTI Part Number	56-0902-006
Manufacturer/Part Number	PHOENIX 15620DY0004-960
PkZ to SMA, RG178 Cable Assembly	
1. Description	Cable Assy, PkZ plug to SMA plug, RG178 cable, 6 Inch
VTI Part Number	56-0903-000
Manufacturer/Part Number	PHOENIX 15620230076-060
2. Description	Cable Assy, PkZ plug to SMA plug, RG178 cable, 12 Inch
VTI Part Number	56-0903-001
Manufacturer/Part Number	PHOENIX 15620230076-120
3. Description	Cable Assy, PkZ plug to SMA plug, RG178 cable, 24 Inch
VTI Part Number	56-0903-002
Manufacturer/Part Number	PHOENIX 15620230076-240
4. Description	Cable Assy, PkZ plug to SMA plug, RG178 cable, 36 Inch
VTI Part Number	56-0903-003
Manufacturer/Part Number	PHOENIX 15620230076-360
5. Description	Cable Assy, PkZ plug to SMA plug, RG178 cable, 48 Inch
VTI Part Number	56-0903-004
Manufacturer/Part Number	PHOENIX 15620230076-480
6. Description	Cable Assy, PkZ plug to SMA plug, RG178 cable, 60 Inch
VTI Part Number	56-0903-005
Manufacturer/Part Number	PHOENIX 15620230076-600
7. Description	Cable Assy, PkZ plug to SMA plug, RG178 cable, 96 Inch
VTI Part Number	56-0903-006
Manufacturer/Part Number	PHOENIX 15620230076-960

APPENDIX C

MEMORY LISTING AND CLEARING PROCEDURE

OVERVIEW

The below table provides the Flash components information used in PXIe Switching Modules. It also contains clearing procedure details for different modules inside the flash components and whether the user can perform writable operation on them or not.

Component	Volatile?	Contains	User Writeable?	Clear Procedure	Models
IC, FLASH MEM,128Mb,3V, WSON8 Part no: 19-0109-000 Man. part: S25FL128SAGNFI003	No	Module identity and Configuration data	No	None	SMX-2002, SMX-2001-10, SMX-2001-12, SMX-2001-16, SMX-2002-10, SMX-2002-12, SMX-3001, SMX-3001DS, SMX-3002, SMX-3002DS, SMX-3003, SMX-3003DS, SMX-3004, SMX-3004DS, SMX-3005, SMX-3005DS, SMX-3006, SMX-3007, SMX-3276, SMX-3276DS, SMX-3277, SMX-3277DS, SMX-3278, SMX-3278DS, SMX-3279, SMX-3279DS, SMX-3280, SMX-3280DS, SMX-4410, SMX-4411, SMX-4412, SMX-4413, SMX-4414, SMX-4415, SMX-5001, SMX-5002, SMX-5004, SMX-6101, SMX-6103, SMX-6105, SMX-6106, SMX-6111, SMX-6115, SMX-6116, SMX-6144, SMX-6101 SMB, SMX-6103 SMB, SMX-6105 SMB, SMX-6106 SMB, SMX-6111 SMB, SMX-6115 SMB, SMX-6116 SMB, SMX-6144 SMB, SMX-7121-18, SMX-7122-18, SMX-7223-18, SMX-7224-18, SMX-7121-26, SMX-7122-26, SMX-7223-26, SMX-7224-26, SMX-7121-40, SMX-7122-40, SMX-7223-40, SMX-7224-40, SMX-7121-50, SMX-7122-50, SMX-7223-50, SMX-7224-50, SMX-7121-67, SMX-7122-67, SMX-7223-67, SMX-7224-67, SMX-7241-06, SMX-7242-06, SMX-7243-06, SMX-7261-06, SMX-7262-06, SMX-7263-06, SMX-7241-26, SMX-7242-26, SMX-7243-26, SMX-7261-26, SMX-7262-26, SMX-7263-26, SMX-7241-40, SMX-7242-40, SMX-7243-40, SMX-7261-40, SMX-7262-40, SMX-7263-40, SMX-72T1-26, SMX-72T2-26, SMX-72T1-40, SMX-72T2-40, SMX-72T1-50, SMX-72T2-50
		FPGA configuration binary			
		Firmware Odometer Values			
		Calibration Data	No	None	SMX-4410
		User defined relay states	Yes	Through SFP "Saved state" option.	SMX-2002, SMX-2001-10, SMX-2001-12, SMX-2001-16, SMX-2002-10, SMX-2002-12, SMX-3001, SMX-3001DS, SMX-3002, SMX-3002DS, SMX-3003, SMX-3003DS,

Component	Volatile?	Contains	User Writeable?	Clear Procedure	Models
					SMX-3004, SMX-3004DS, SMX-3005, SMX-3005DS, SMX-3006, SMX-3007, SMX-3276, SMX-3276DS, SMX-3277, SMX-3277DS, SMX-3278, SMX-3278DS, SMX-3279, SMX-3279DS, SMX-3280, SMX-3280DS SMX-4410, SMX-4411, SMX-4412, SMX-4413, SMX-4414, SMX-4415, SMX-5001, SMX-5002, SMX-5004 SMX-6101, SMX-6103, SMX-6105, SMX-6106, SMX-6111, SMX-6115, SMX-6116, SMX-6144, SMX-6101 SMB, SMX-6103 SMB, SMX-6105 SMB, SMX-6106 SMB, SMX-6111 SMB, SMX-6115 SMB, SMX-6116 SMB, SMX-6144 SMB, SMX-7121-18, SMX-7122-18, SMX-7223-18, SMX-7224-18, SMX-7121-26, SMX-7122-26, SMX-7223-26, SMX-7224-26, SMX-7121-40, SMX-7122-40, SMX-7223-40, SMX-7224-40, SMX-7121-50, SMX-7122-50, SMX-7223-50, SMX-7224-50, SMX-7121-67, SMX-7122-67, SMX-7223-67, SMX-7224-67, SMX-7241-06, SMX-7242-06, SMX-7243-06, SMX-7261-06, SMX-7262-06, SMX-7263-06, SMX-7241-26, SMX-7242-26, SMX-7243-26, SMX-7261-26, SMX-7262-26, SMX-7263-26, SMX-7241-40, SMX-7242-40, SMX-7243-40, SMX-7261-40, SMX-7262-40, SMX-7263-40, SMX-72T1-26, SMX-72T2-26, SMX-72T1-40, SMX-72T2-40, SMX-72T1-50, SMX-72T2-50
IC, CPLD, 64 MACROCELLS, 7.5ns, 1.8V, 48PIN, QFG PKG Part no:21-0105-064 Man. part: XC2C64A-7QFG48C		CPLD with configuration binary	No	None	SMX-2002, SMX-2001-10, SMX-2001-12, SMX-2001-16, SMX-2002-10, SMX-2002-12 SMX-3001, SMX-3001DS, SMX-3002, SMX-3002DS, SMX-3003, SMX-3003DS, SMX-3004, SMX-3004DS, SMX-3005, SMX-3005DS, SMX-3006, SMX-3007, SMX-3276, SMX-3276DS, SMX-3277, SMX-3277DS, SMX-3278, SMX-3278DS, SMX-3279, SMX-3279DS, SMX-3280, SMX-3280DS SMX-4410, SMX-4411, SMX-4412, SMX-4413, SMX-4414, SMX-4415, SMX-5001, SMX-5002, SMX-6101, SMX-6103, SMX-6105, SMX-6106, SMX-6111, SMX-6115, SMX-6116, SMX-6144, SMX-6101 SMB, SMX-6103 SMB, SMX-6105 SMB, SMX-6106 SMB SMX-7121-18, SMX-7122-18, SMX-7223-18, SMX-7224-18, SMX-7121-26, SMX-7122-26, SMX-7223-26, SMX-7224-26, SMX-7121-40, SMX-7122-40, SMX-7223-40, SMX-7224-40, SMX-7121-50, SMX-7122-50, SMX-7223-50, SMX-7224-50, SMX-7121-67, SMX-7122-67, SMX-7223-67, SMX-7224-67, SMX-7241-06, SMX-7242-06, SMX-7243-06, SMX-7261-06, SMX-7262-06, SMX-7263-06, SMX-7241-26, SMX-7242-26, SMX-7243-26, SMX-7261-26, SMX-7262-26, SMX-7263-26, SMX-7241-40, SMX-7242-40, SMX-7243-40, SMX-7261-40, SMX-7262-40, SMX-7263-40, SMX-72T1-26, SMX-72T2-26, SMX-72T1-40, SMX-72T2-40, SMX-72T1-50, SMX-72T2-50

NOTE SMX-61xx models without SMB in model name are SMX-61xx models with PkZ connector

APPENDIX D

The following table provide MTBF of SMX Models.

Sl.no.	Model	MTBF 40°C (Hours)
1	SMX-2002, SMX-2001-10, SMX-2001-12, SMX-2001-16, SMX-2002-10, SMX-2002-12	250,000
2	SMX-3001, SMX-3001DS	800,000
3	SMX-3002, SMX-3002DS	800,000
4	SMX-3003, SMX-3003DS	800,000
5	SMX-3004, SMX-3004DS	800,000
6	SMX-3005, SMX-3005DS	800,000
7	SMX-3006	800,000
8	SMX-3007	800,000
9	SMX-3276, SMX-3276DS	800,000
10	SMX-3277, SMX-3277DS	800,000
11	SMX-3278, SMX-3278DS	800,000
12	SMX-3279, SMX-3279DS	800,000
13	SMX-3280, SMX-3280DS	800,000
14	SMX-4410, SMX-4411, SMX-4412, SMX-4413, SMX-4414, SMX-4415	800,000
15	SMX-5001	800,000
16	SMX-5002, SMX-5004	800,000
17	SMX-6101, SMX-6103, SMX-6105, SMX-6106	800,000
18	SMX-6111, SMX-6115, SMX-6116, SMX-6144	800,000
19	SMX-6101 SMB, SMX-6103 SMB, SMX-6105 SMB, SMX-6106 SMB	800,000
20	SMX-6111 SMB, SMX-6115 SMB, SMX-6116 SMB, SMX-6144 SMB	800,000
21	SMX-7121-18, SMX-7122-18, SMX-7223-18, SMX-7224-18, SMX-7121-26, SMX-7122-26, SMX-7223-26, SMX-7224-26, SMX-7121-40, SMX-7122-40, SMX-7223-40, SMX-7224-40, SMX-7121-50, SMX-7122-50, SMX-7223-50, SMX-7224-50, SMX-7121-67, SMX-7122-67, SMX-7223-67, SMX-7224-67, SMX-7241-06, SMX-7242-06, SMX-7243-06, SMX-7261-06, SMX-7262-06, SMX-7263-06, SMX-7241-26, SMX-7242-26, SMX-7243-26, SMX-7261-26, SMX-7262-26, SMX-7263-26, SMX-7241-40, SMX-7242-40, SMX-7243-40, SMX-7261-40, SMX-7262-40, SMX-7263-40, SMX-72T1-26, SMX-72T2-26, SMX-72T1-40, SMX-72T2-40, SMX-72T1-50, SMX-72T2-50	615,000

NOTE SMX-61xx models without SMB in model name are SMX-61xx models with PkZ connector

APPENDIX E

WEB PAGE OPERATION(SFP)

OPENING THE WEB PAGE

To open the embedded web page, open any web browser and enter the IP address or hostname of the EMX-2500 into the address bar. By default, the EMX-2500 will first attempt to use DHCP to set its IP address. If DHCP is not available on the network, it will instead use Auto IP.

GENERAL WEB PAGE OPERATION

When initially connected to the EMX-2500, the instrument home page, or **Index**, appears. This page displays instrument-specific information (see the *Index* section for details). This page is accessible from any other instrument page by clicking on the EMX-2500 web page header. The EMX-2500 Navigation Menu is displayed on the left side of every internal web page. The entries on the Navigation Menu represent two types of pages:

- **Status:** These pages perform no actions and accept no entries. It provides operational status and information only. The **Index** page is an example of a status page.
- **Entry:** These pages display and accept changes to the configuration of the instrument. The **Network Configuration** page is an example of an entry page.

Use of the entry-type web pages in the EMX-2500 are governed by a common set of operational characteristics:

- Pages initially load with the currently-entered selections displayed.
- Each page contains a **Submit** button to accept newly entered changes. Leaving a page before submitting any changes has the effect of canceling the changes, leaving the instrument in its original state.
- Navigation through a parameter screen is done with the *Tab* key. The *Enter* key has the same function as clicking the Submit button and cannot be used for navigation.

INDEX

The **Index** page provides the general information about the EMX-2500.

The screenshot shows the SentinelEX Index page. The top navigation bar includes the VTI Instruments logo, the page title 'SentinelEX Index', and links for 'Contact', 'Support', and 'VTI Home'. The LXI logo is also present. A sidebar on the left contains icons and labels for various configuration options: Index, Cards, Network Configuration, Time Configuration, LXI Synchronization, LXI Identification, Blink LAN Indicator, Change Password, Upgrade, Reset, and Reboot. The main content area displays a table of system information.

Model	EMX-2500
Manufacturer	VTI Instruments Corporation
Serial Number	687001
Description	VTI SentinelEX EMX-2500 - 687001
LXI Version	1.4 LXI Core 2011
Extended Functions	LXI Event Messaging LXI Clock Synchronization LXI Timestamped Data LXI Event Log LXI IPv6
Hostname	EMX-2500-687001.local. EMX-2500-687001.cle.vtiinstruments.lci
MAC Address	00:0d:3f:01:24:f5
IPv4 Address	10.20.10.158
IPv6 Address	fe80::20d:3fff:fe01:24f5
Instrument Address String	TCPIP::10.20.10.158::INSTR TCPIP::[fe80::20d:3fff:fe01:24f5]:INSTR
Firmware Revision	1.3.2
IEEE-1588 Time	1373399915.75
Current source of time	PTP2
Local time	Tue Jul 9 15:59:10 EDT 2013

Copyright 2013, VTI Instruments Corporation

FIGURE 3-120: INDEX PAGE

- **Model:** The model number of the module.
- **Manufacturer:** The module manufacturer.
- **Serial Number:** The module's serial number.
- **Description:** A brief, user-configurable description of the module.
- **LXI Version:** Indicates the LXI specification version to which the module conforms.
- **Extended Functions:** Indicates which LXI Extended functions are supported.
- **Hostname:** Indicates the Full Qualified Domain Names of the module. The first part of each FQDN is the user-configured hostname.
- **MAC Address:** Indicates the factory-assigned MAC address of the module.
- **IPv4 Address:** Indicate the current IPv4 address of the module.
- **IPv6 Address:** Indicates the current IPv6 address(es) of the module.
- **Instrument Address String:** Indicates the resource string(s) by which the module can be accessed via its instrument driver.
- **Firmware Revision:** Indicates the current revision of the module's firmware.
- **IEEE 1588 Time:** The current IEEE 1588 time.
- **Current Source of Time:** Indicates from which source the module is deriving its time.
- **Local Time:** The module's current time, as expressed in the currently configured time zone.

CARDS

The **Cards** page lists all modules currently installed in the chassis in which the EMX-2500 is acting as controller module.

Device	Model	Revision	Serial	Description	Resource
Slot 0.1	EMX-2500	1.14.15	208841	LXI Interfaced modular PXIe instrument.	TCPIP::10.214.52.51::slot0_1::INSTR
Slot 0.3	SMX-2002	1.2.5	700711	Switch module	TCPIP::10.214.52.51::slot0_3::INSTR

FIGURE 3-146: SMX CARDS WEB PAGE

The following information is provided for each module:

- **Device:** The bus and slot number of the module.
- **Model:** The model number of the module.
- **Revision:** The firmware version of the module.
- **Serial:** The serial number of the module.
- **Description:** A brief description of the module.
- **Resource:** A resource string that can be used to access the module via its instrument driver.

NETWORK CONFIGURATION

The **Network Configuration** page contains information concerning the configuration of the EMX-2500's network interfaces and provides the ability to modify it.

FIGURE 3-122: NETWORK CONFIGURATION PAGE

- **IPv4 Address Source:** The IPv4 address for the EMX-2500 is determined by one of three sequenced mechanisms: **DHCP** → **AutoIP** → **Static**. If an IP address cannot be obtained with the first mechanism, it will progress to the next method. The user also has the ability to enable or disable either of these methods by utilizing the adjacent checkboxes.
 - **DHCP:** A protocol that obtains an IP address automatically if the EMX-2500 is connected to a network with a DHCP server. By default, the EMX-2500 will attempt to locate a DHCP server. If one is found, the IP address assigned by the DHCP server will be assumed. Otherwise, after a timeout of 20 seconds, the unit will attempt to obtain an IP address by using AutoIP.
 - **AutoIP:** A protocol that automatically creates a link-local IP address based on the EMX-2500's MAC address. If the IP address created is not available on a network, another IP will be chosen randomly.
 - **Static:** A user-configured IP address which remains constant. Both DHCP and AutoIP generated IP addresses may change after a reset condition.
- **Disable IPv6:** When checked, IPv6 addressing will be disabled and the EMX-2500 will only be accessible via IPv4.
- **Hostname:** Indicates a name which other devices may use to communicate with the EMX-2500 instead of using its IP address. When mDNS service discovery is used, the host name for the unit will appear. The default hostname is "EMX-2500-[serial number]". To reset the hostname to the factory default, delete the current value and submit the page with nothing in this field.
- **Device Description:** This user-configurable field can be used to provide additional information regarding the module (i.e. location, use, etc.). This is visible on the **Index** page without the need for a password. If set, this description will be used as the Service Name for mDNS service discover instead of the hostname above. To reset the description to the factory default, delete the current value and submit the page with nothing in this field.
- **Static IP Configuration:** This configuration section is used to create a static IP address.
 - **IP Address:** The user-configured IP address is entered into this text field.
 - **Subnet Mask:** Defines the range of IP addresses the EMX-2500 will attempt to connect to directly (255.255.255.0 means match all but the last number, etc.).
 - **Gateway Address:** The IP address of a server that EMX-2500 can use to contact IP addresses external to its network.

- **DNS Servers:** This field is used to provide the IP addresses of servers that the EMX-2500 module may use to look up hostnames.
- **Network Status:** Indicates the current network settings for the EMX-2500's IPv4 Address, Subnet Mask, Gateway Address, MAC Address, and IPv6 Address.

TIME CONFIGURATION

The **Time Configuration** page contains information concerning the configuration of the EMX-2500's source of time and provides the ability to modify it.

Time Configuration	
Time Zone	US/Eastern
Time Source	PTP2
NTP Server	
Set Time	<input checked="" type="checkbox"/>
Date (MM:DD:YYYY)	6 14 2013
Time (HH:MM:SS)	10 21 12
Time Status	
Current Time	Fri Jun 14 10:21:42 EDT 2013
PTP Status	Slave
Offset from Master (ns)	1
<input type="button" value="Submit"/>	

FIGURE 3-147: TIME CONFIGURATION PAGE

- **Time Configuration**
 - **Time Zone:** Allows the user to select the time zone for displaying the current local time.
 - **Time Source:** Selects the method to use for setting the EMX-2500's time.
 - **PTP2:** *Precision Time Protocol Version 2* (IEEE 1588-2008) will be used to synchronize the EMX-2500's time with a master clock on the network, or to act as master clock based on the IEEE 1588 Best Master Clock algorithm.
 - **NTP:** *Network Time Protocol* will be used to synchronize the EMX-2500's time to a remote server, which is specified in the **NTP Server** field below.
 - **Manual:** The time will be set manually by the user via the **Set Time** option below.
 - **NTP Server:** The IP address or hostname of the server from which to derive time when the **NTP** option is selected. If this is left blank, one of the following values will be used by instead:
 - If the EMX-2500 is configured for DHCP, and if the DHCP server supplies the address of an NTP server, that will be used. Otherwise, the default value of pool.ntp.org will be used.
 - **Set Time:** Checking the **Set Time** box causes the **Date** and **Time** fields to appear. They will be automatically populated with the current time of the user's PC. When using the **Manual** option, this sets the EMX-2500's current date and time. When using the **PTP2** option, this causes a message to be sent to the current master clock, requesting that it set its time.
- **Time Status**
 - **Current Time:** The current date and time of the EMX-2500, translated to the UTC time-base and the selected time zone.
 - **PTP Status:** The current state of the **PTP2** protocol within the EMX-2500.

- **Offset From Master (ns):** An estimate of the current error, in nanoseconds, of the EMX-2500's time from that of its PTP master.

LXI SYNCHRONIZATION

The **LXI Synchronization** page provides status on the EMX-2500's synchronization status.

IEEE 1588 Parameters	
PTP Grandmaster Clock MAC	00:0d:3f:01:1f:78
PTP Parent Clock MAC	00:0d:3f:01:1f:78
PTP Version	2
PTP State	Slave
Current PTP time	1371219760.42
Current Local Time	Fri Jun 14 10:23:15 EDT 2013
Grandmaster Traceability to UTC	INTERNAL_OSCILLATOR
Current Observed Variance of Parent	Unavailable
IEEE 1588 Domain	0
LXI Module-to-Module Parameters	
LXI Domain	0

FIGURE 3-124: LXI SYNCHRONIZATION PAGE

- **IEEE 1588 Parameters**
 - **PTP Grandmaster Clock MAC:** The MAC address of the device on the network to which all other IEEE 1588 compliant devices are synchronized.
 - **PTP Parent Clock MAC:** The MAC address of the device to which the EMX-2500 is synchronized. In a hierarchical IEEE 1588 system with boundary clocks, this indicates the MAC address of the parent clock on the local link.
 - **PTP State:** Indicates whether the EMX-2500 is initializing, faulty, disabled, listening, pre-master, master, passive, uncalibrated, or slave.
 - **Current PTP Time:** The current time on the EMX-2500, expressed as the number of seconds since midnight January 1, 1970 TAI.
 - **Current Local Time:** The current date and time of the EMX-2500, translated to the UTC time-base and the selected time zone.
 - **Grandmaster Traceability to UTC:** Indicates how the grandmaster is synchronized to UTC. The values provide an indicator of how closely synchronized the grandmaster is to UTC time.
 - **Current Observed Variance of Parent:** This function is not supported by the EMX-2500.
 - **IEEE 1588 Domain:** The instrument's PTP domain. Typically, this indicator is 0.
 - **LXI Module to Module Parameters**
 - **LXI Domain:** An 8-bit number, 0 to 255, which indicates the domain the EMX-2500 is using for LAN Events. All events sent by this device will include this number. Likewise, the device will only accept events that include the same LXI Domain number.

LXI IDENTIFICATION

The **LXI Identification** page is an XML document providing identifying information on the EMX-2500 and the other modules installed in the chassis in which it is acting as controller.

EMX-2500 LXI Identification	
Manufacturer	VTI Instruments Corporation
Model	EMX-2500
SerialNumber	208841
FirmwareRevision	1.14.15
ManufacturerDescription	LXI Interfaced modular PXIe instrument.
HomepageURL	https://www.powerandtest.com
DriverURL	https://www.powerandtest.com/searchresult?userinput=EMX-2500
DeviceURI	http://10.214.52.51/card/slot0_1/
DeviceURI	http://10.214.52.51/card/slot0_3/
UserDescription	VTI SentinelEX EMX-2500 - 208841
IdentificationURL	http://10.214.52.51/hi/identification
InstrumentAddressString	TCP/IP:EMX-2500-208841.ametek.com::INSTR
Hostname	EMX-2500-208841.ametek.com
IPAddress	10.214.52.51
SubnetMask	255.255.240.0
MACAddress	00:0d:3f:01:3b:0a
Gateway	10.214.48.1
DHCPEnabled	true
AutoIPEnabled	true
InstrumentAddressString	TCP/IP:[fe80::20d:3ff:fe01:3b0a]::INSTR
Hostname	EMX-2500-208841.ametek.com
IPAddress	fe80::20d:3ff:fe01:3b0a
SubnetMask	64
MACAddress	00:0d:3f:01:3b:0a
Gateway	
DHCPEnabled	false
AutoIPEnabled	false
IVI SoftwareModuleName	VTEXPlatform "VTI Platform Driver"
IVI SoftwareModuleName	VTEXSwitch "Driver for VTI switch modules"
Domain	0
LXI Version	1.4 LXI Core 2011
Function	"LXI Event Messaging" "1.0"
Function	"LXI Clock Synchronization" "1.0"
Function	"LXI Timestamped Data" "1.0"
Function	"LXI Event Log" "1.0"
Function	"LXI IPv6" "1.0"

FIGURE 3-125: LXI IDENTIFICATION PAGE

- **Manufacturer:** The module manufacturer.
- **Model:** The model number of the module.
- **SerialNumber:** The module's serial number.
- **FirmwareRevision:** Indicates the current revision of the module's firmware.
- **ManufacturerDescription:** A brief description of the module.
- **HomepageURL:** The address of the manufacturer home page.
- **DeviceURI:** Indicates the URI of the identification page of a sub-device connected to the module.
- **UserDescription:** The user-configurable description field.
- **IdentificationURL:** The canonical URL of this document.
- **Network Interface Information:** The following fields will be repeated once for each network interface present in the module:
 - **InstrumentAddressString:** Indicates the resource string by which the module can be accessed via its instrument driver.
 - **Hostname:** Indicates the Full Qualified Domain Name of the module. The first part of the FQDN is the user-configured hostname.
 - **IP Address:** Indicate the current IP address of the module.
 - **SubnetMask:** Indicates the range of IP addresses the EMX-2500 will attempt to connect to directly.
 - **MAC Address:** Indicates the factory-assigned MAC address of the module.
 - **Gateway:** The IP address of a server that EMX-2500 can use to contact IP addresses external to its network.
 - **DHCPEnabled:** Indicates whether DHCP is enabled on the interface.
 - **AutoIPEnabled:** Indicates whether AutoIP is enabled on the interface.
- **IVI SoftwareModuleName:** Indicates the name and description of an IVI-compliant instrument driver that can be used to control the instrument.
- **Domain:** The LXI LAN Event Domain number, 0-255.
- **LXI Version:** Indicates the LXI specification version to which the module conforms.

- **Function:** Indicates an LXI Extended Function, and its version, that is supported by the module.

BLINK LAN INDICATOR

The **Blink LAN Indicator** page allows identification of the device being accessed by causing its LAN LED to blink.

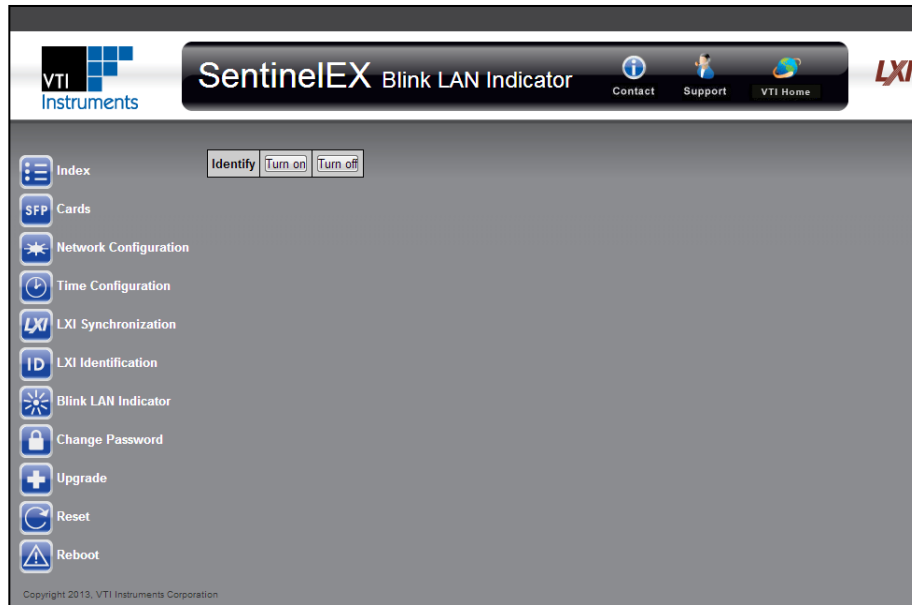

FIGURE 3-126: BLINK LAN INDICATOR PAGE

- **Turn On:** Cause the EMX-2500's LAN LED to blink.
- **Turn Off:** Cause the EMX-2500's LAN LED to stop blinking.

CHANGE PASSWORD

The **Change Password** page allows the password to be updated.

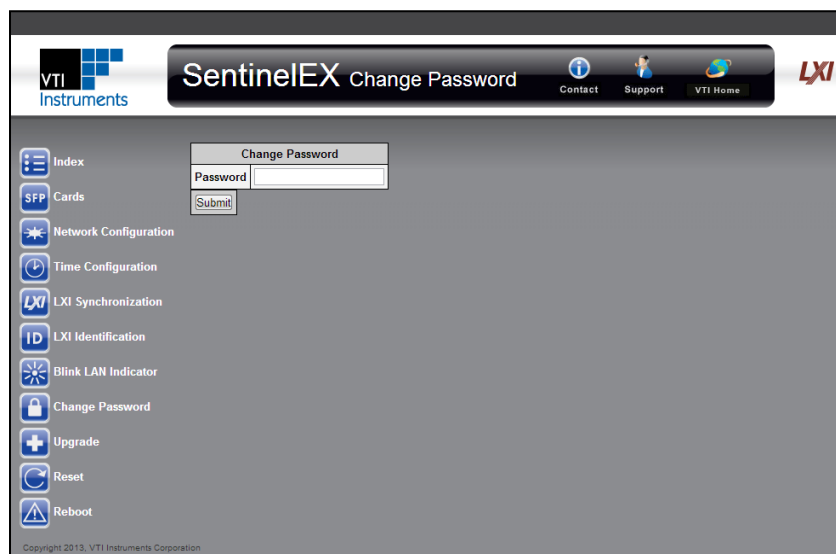

FIGURE 3-127: CHANGE PASSWORD PAGE

- **Password:** Set a new password to control access to configuring the EMX-2500. Setting an empty password disables password requirements.

UPGRADE

The **Upgrade** web page provides the ability to upgrade the firmware of the EMX-2500 and other modules in the chassis it is acting as controller of. Upgrade files are available from the *VTI Instruments User's Manuals and Drivers CD*, or from the VTI Instruments web site, at <http://www.vtiinstruments.com/Downloads.aspx>.

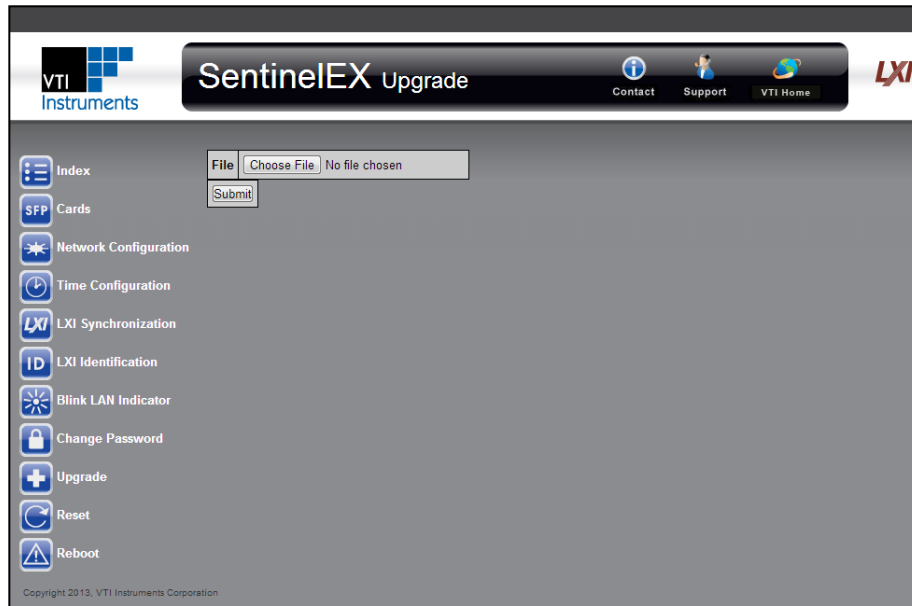

FIGURE 3-128: UPGRADE PAGE

- **File:** Allows the user to browse to find their desired upgrade file.

RESET

The **Reset** page allows all the EMX-2500 and modules in the chassis it is acting as controller of to be returned to power-on default settings. This operation is faster than a reboot, but does not load new firmware.

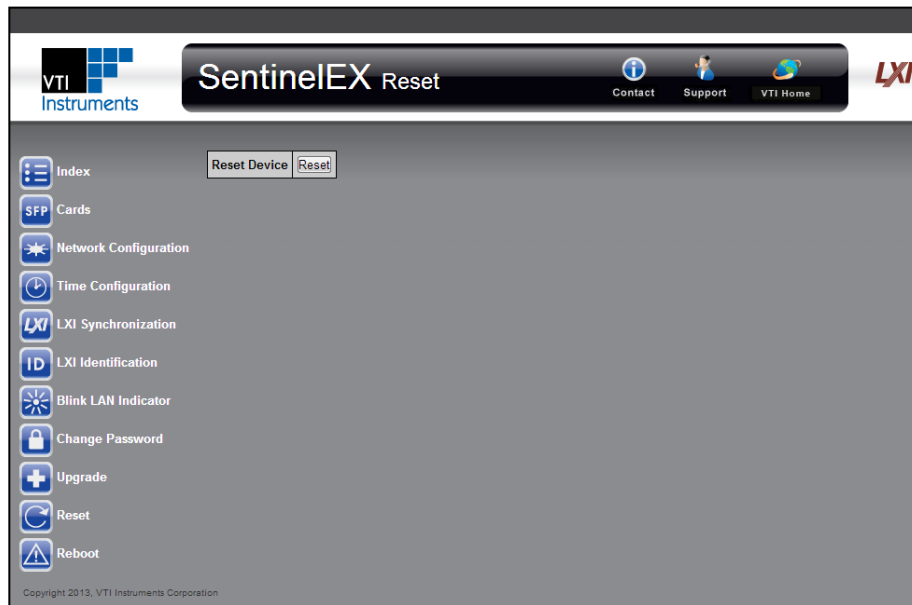

FIGURE 3-129: RESET WEB PAGE

- **Reset:** Click this button to reset the EMX-2500 and all peripheral cards to power-on defaults.

REBOOT

The **Reboot** web page allows the EMX-2500 to reboot the chassis it is installed into. This operation has the same effect as power-cycling the chassis – all modules will re-load firmware from nonvolatile memory and return to power-on defaults.

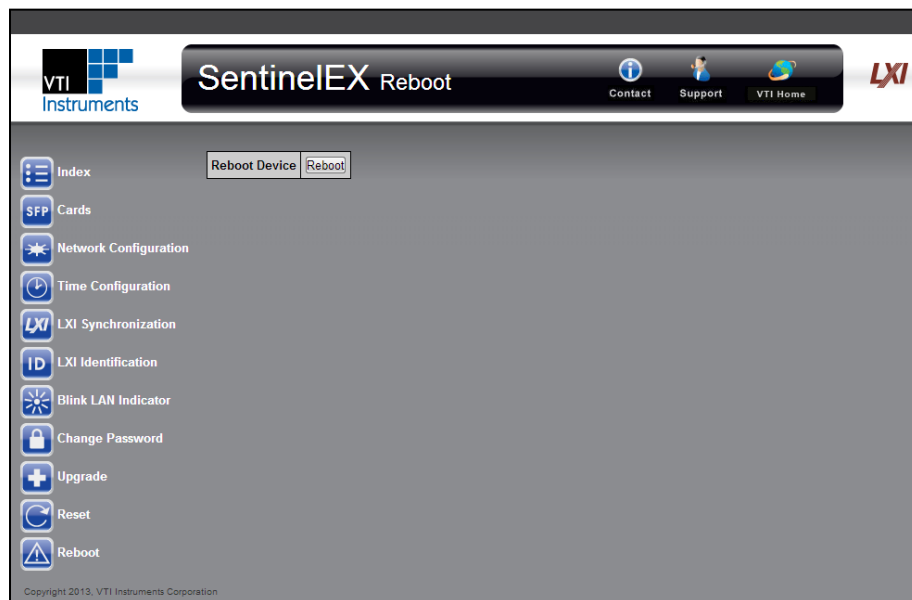

FIGURE 3-130: REBOOT PAGE

- **Reboot Device:** Click this button to reboot the EMX-2500, the chassis in which its installed, and all peripheral cards.

SWITCH CARDS SOFT FRONT PANELS

Each switch card has its own, unique soft front panel which paths to be defined, relays to be opened and/or closed, and for user defined states to be created which can be recalled for later use.

Click on the Slot number to access corresponding SMX Switch card SFP, in this section SMX-2002 switch card SFP is used for reference.

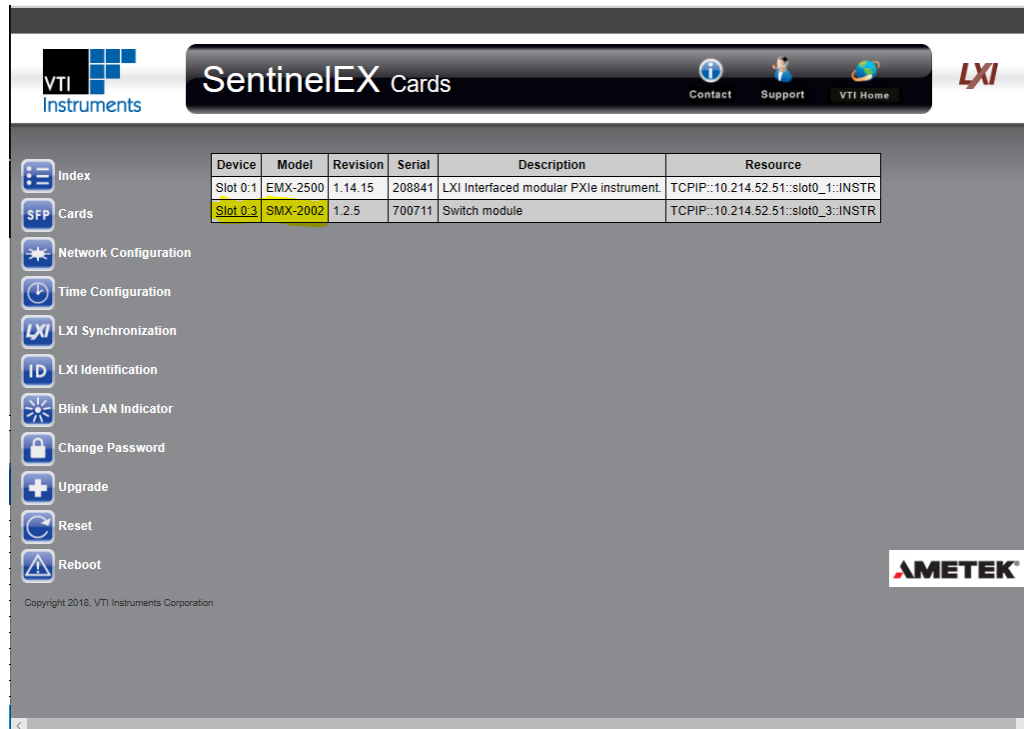

FIGURE 3-131: SFP SWITCH CARD SELECTION

Control Mode

By default, the SFP opens to the **Control Mode** view. From this view, the user can see the logical diagram for the selected plug-in module. To control a switch, for example, simply click on the pin that needs to be activated to cause the internal relay to actuate and connect to the pin indicated. Horizontal and vertical scroll bars allow the user to navigate larger diagrams by scrolling. The user may also change the magnification of the schematic. The size of the schematic can be changed from to any of the following sizes: Fit to Width, Fit to Window and Full Size.

The main toolbar of the SFP provides the following functionality:

- **Control Mode:** Three control modes are available for SMX Switch modules.
 - **Monitor Only:** In this mode, the user can view the actions the various SMX card Switches while the module is actively performing automated test. The image is refreshed every 3 s. In this mode, no modifications can be made. If another user has established a session with the SMX Switch card, all other sessions established after that will be “Monitor Only” sessions until the previous session has ended.
 - **Synchronous Mode:** In this mode, the user can manipulate the relays of SMX Switch card in real time. As the user operates relay it affects the SMX Switch card switch relay at that time.

- **Asynchronous Mode:** In this mode, the user may manipulate all relays, but the actions do not occur until after the **Apply** button is clicked. Clicking on the **Revert** button will cause the plug-in to revert to the state they were in the last time **Apply** was clicked.

Notes on Web Page Use
 Before controlling relays, set the control mode to either **Synchronous** or **Asynchronous**.

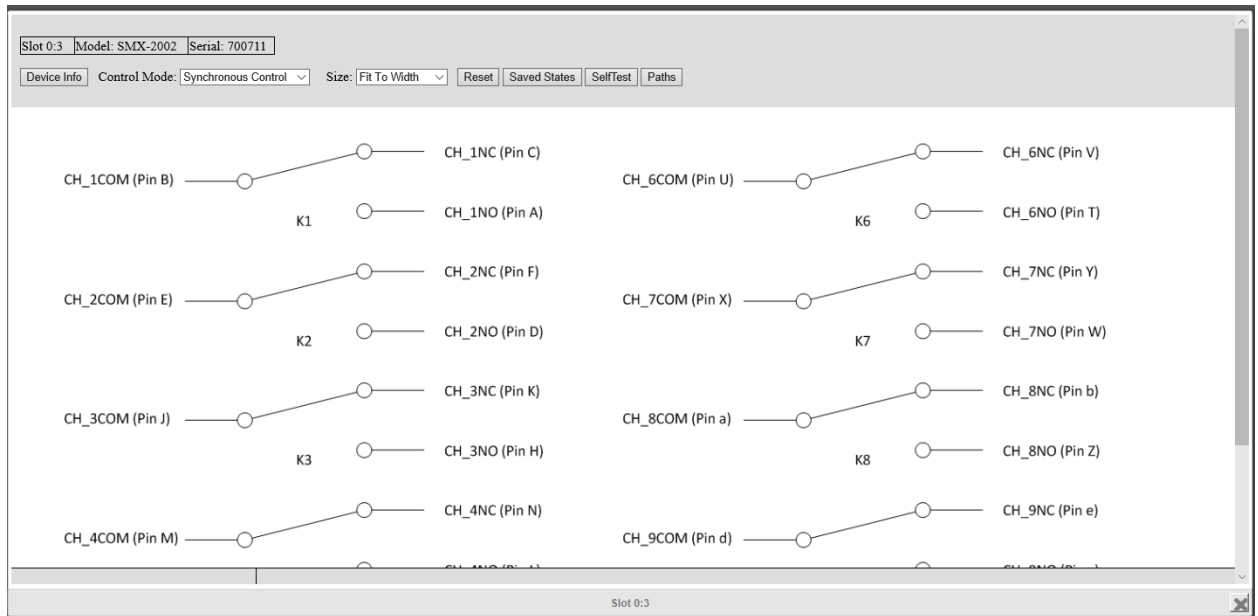

FIGURE 3-148: SMX-2002 SWITCH CARD SFP PAGE

- **Saved States** button: This button allows the user to either save, load, or erase a switch configuration. Saving a state allows the user to use the same switch set up at a later time. When the **Save** button is clicked, a prompt will appear. The user selects a number, 0 through 127, from this field. Click **OK** to save the current state as the state number entered. To load or erase a saved state, simply click on the **Load** or **Erase** button, select the desired state number from the dialog box that appears, and then click **OK**.

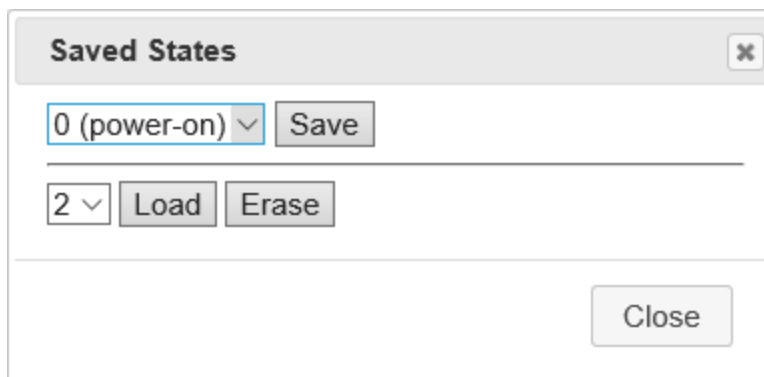

FIGURE 3-149: SMX-2002 SWITCH CARD SAVED STATES

- **Self Test button** displays switch card self test interface through which the health status of the switch card relays can be checked.
- **Path button:** This button opens the **Path** configuration window. From this window, the user can define channel-to-channel relationships by entering the desired path in the New Path text box using the formatting described in the **Help** discussion. Clicking on the **Connect** button will close the relays required to establish the **Path**. Once defined, the path can be found in the **Established Paths** text box. The path can then be established or removed by using the **Reconnect** and **Disconnect** buttons. The **Details** button provides information about the path selected in the **Established Paths** text box.

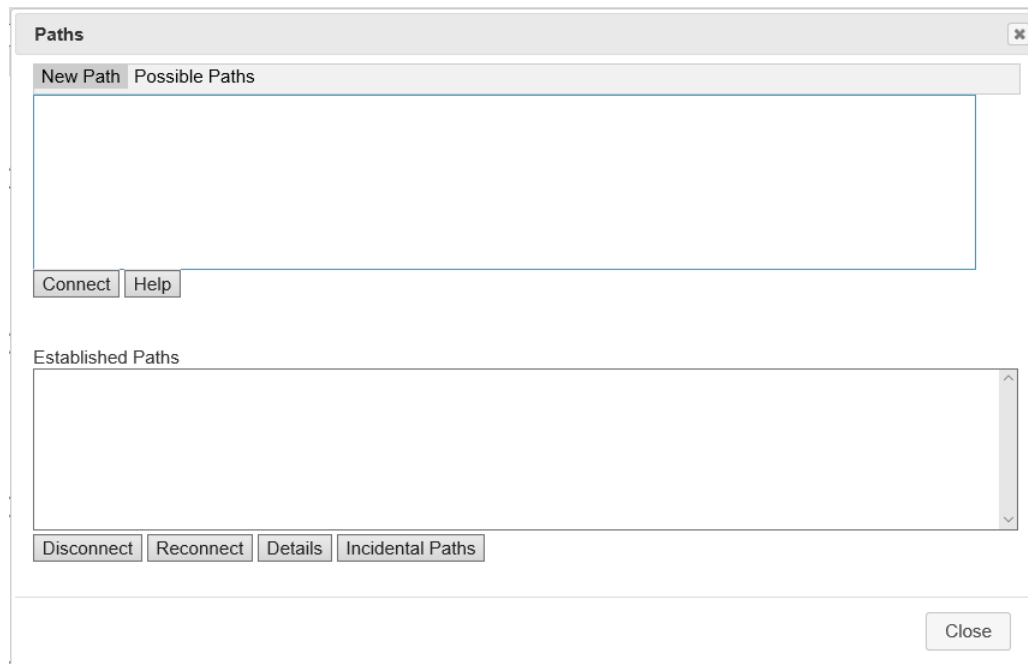

FIGURE 3-15034: SMX-2002 SWITCH CARD PATHS

- **Device Info** displays instrument information including Slot, Model, Serial number, Firmware Version, Assembly Revision, SFP Version, FPGA Version, CPLD Version and DCF Version

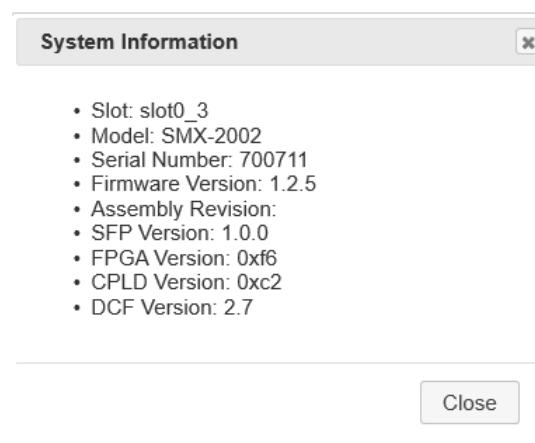

FIGURE 3-15135: SMX-2002 SWITCH CARD DEVICE INFO