

ENERGIZER A522

9V

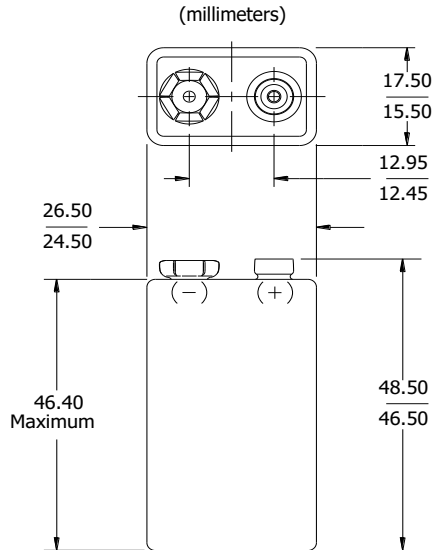

Industry Standard Dimensions



Specifications

Classification:	Alkaline
Chemical System:	Zinc-Manganese Dioxide (Zn/MnO ₂) No added mercury or cadmium
Designation:	ANSI 1604A, IEC-6LF22 or 6LR61
Nominal Voltage:	9.0 volts
Operating Temp:	-18°C to 55°C
Typical Weight:	45 grams
Typical Volume:	21 cubic centimeters
Shelf Life:	5 years at 21°C
Terminal:	Miniature Snap

Performance Comparison

A522 vs. Typical Carbon Zinc (9V) at 21°C

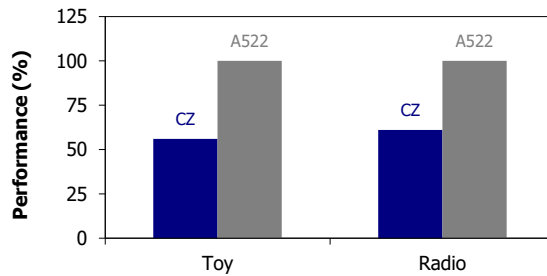

Industry Standard Testing Protocol

Device Selection Guide:

- Toy
- Baby Monitor
- Garage Opener
- Clock Radio
- Smoke Detector

Battery Selection Indicator

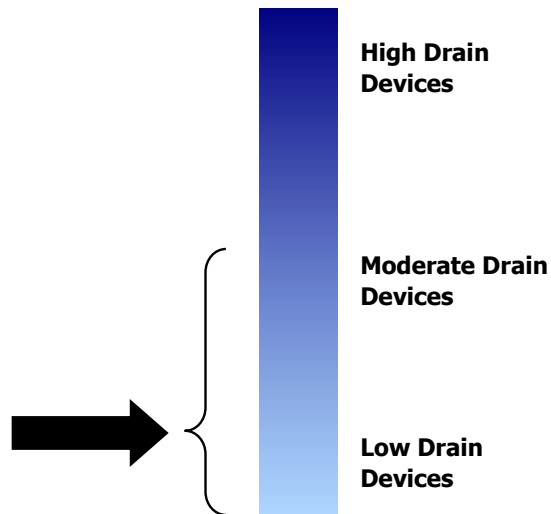

Important Notice

This data sheet contains typical information specific to products manufactured at the time of its publication.
Contents herein do not constitute a warranty and are for reference only.