

6-channel high-side driver with 24-bit SPI interface for automotive applications

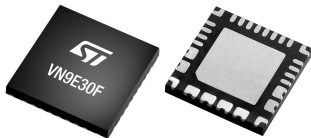

QFN 6x6

Product status link

[VN9E30F](#)

Product summary

| | |
|-------------------|---------------|
| Order code | VN9E30FTR |
| Package | QFN 6X6 |
| Packing | Tape and reel |

Features

| Channel | V _{CC} | R _{ON} typ. | I _{LIMH} typ. |
|---------|-----------------|----------------------|------------------------|
| 0-5 | 28 V | 30 mΩ | 35 A |

- AEC-Q100 qualified 
- General
 - Extremely low voltage operation for deep cold cranking applications (compliant with LV124, revision 2013)
 - Integrated PWM engine with independent phase shift and frequency generation (for each channel)
 - 24-bit ST-SPI for full diagnostics and digital current sense feedback
 - Integrated 10-bit ADC for digital current sense
 - Programmable bulb/LED mode for all channels
 - Advanced limp-home functions for robust fail-safe system
 - Very low standby current
 - Optimized electromagnetic emissions
 - Very low electromagnetic susceptibility
 - Control through direct inputs and/or SPI
 - Compliant with European directive 2002/95/EC
- Diagnostics functions
 - Digital proportional load current sense
 - Synchronous diagnostics of overload and short-to-GND, output shorted to V_{CC} and OFF-state open-load events
 - Programmable case overtemperature warning
- Protection
 - Two-level load current limitation
 - Self-limiting of fast thermal transients
 - Undervoltage shutdown
 - Overvoltage clamp
 - Latch-off or programmable time-limited auto-restart (power limitation and overtemperature shutdown)
 - Load dump protected
 - Protection against loss of ground

Description

The VN9E30F is a device made using STMicroelectronics VIPower technology. It is intended for driving resistive or inductive loads directly connected to ground. The device is protected against voltage transient on the V_{CC} pin (see ISO7637 transient compatibility table). Programming, control and diagnostics are implemented via the SPI bus. A digital current sense feedback for each channel is provided through an integrated 10-bit ADC with 0.1% of FSR. Dedicated trimming bits allow to adjust the ADC reference current. The device is equipped with 6 outputs controllable via SPI or with the 2-OTP assignable direct inputs. The device detects open-load in OFF-state conditions. Real time diagnostics is available through the SPI bus (open-load, output short to V_{CC} , overtemperature, communication error, power limitation or latch off). Output current limitation protects the device in an overload condition. The device can limit the dissipated power to a safe level up to thermal shutdown intervention. Thermal shutdown can be configured as latched off or programmable time-limited auto-restart. The device enters a limp home mode in case of loss of digital supply (V_{DD}), reset of digital memory or watchdog monitoring time-out event. In limp home mode, each output is set according to the programmed register to be always OFF or according to the 2x direct inputs pins.

1 Block diagram and pin description

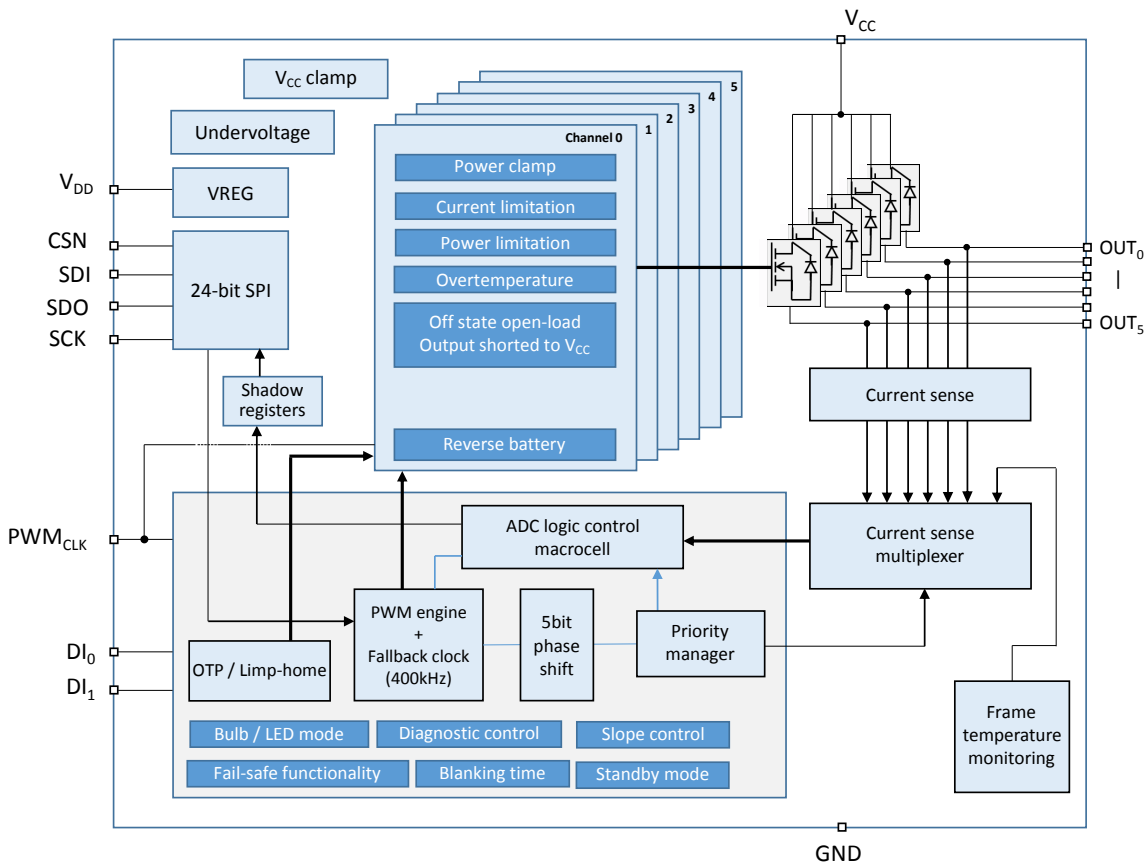
Figure 1. Block diagram

GADG010320191111MT

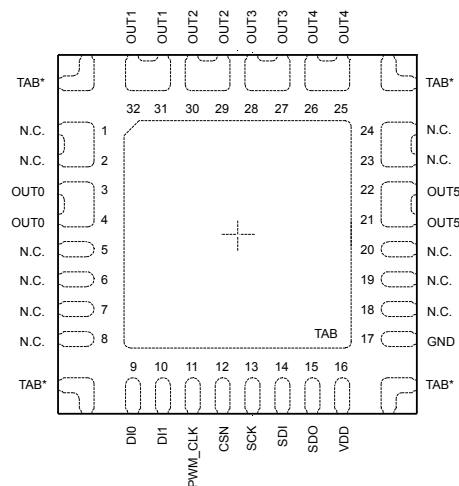
Figure 2. Connection diagram (top view)

*: Electrically connected to TAB. Those pins are intended for thermo-mechanical purposes only. They have to be soldered, but must be electrically isolated at PCB level.

Table 1. Pin functionality description

| Pin # | Name | Function |
|-------|-----------------|--|
| Tab | V _{CC} | Battery connection. This is the backside TAB and is the direct connection to drain Power MOSFET switches. |
| 17 | GND | Ground connection. This pin serves as the ground connection for the logic part of the device. |
| 9-10 | DI0, DI1 | Direct Input. Direct control for OUTx in Limp Home mode through OTP programmed Direct Input assignment. Configurable as OR combination with the relevant SPI OUTx Control bit in Normal mode. |
| 3-4 | OUT0 | Power OUTPUT 0. It is the direct connection to the source Power MOSFET switch No. 0. |
| 31-32 | OUT1 | Power OUTPUT 1. It is the direct connection to the source Power MOSFET switch No. 1. |
| 29-30 | OUT2 | Power OUTPUT 2. It is the direct connection to the source Power MOSFET switch No. 2. |
| 27-28 | OUT3 | Power OUTPUT 3. It is the direct connection to the source Power MOSFET switch No. 3. |
| 25-26 | OUT4 | Power OUTPUT 4. It is the direct connection to the source Power MOSFET switch No. 4. |
| 21-22 | OUT5 | Power OUTPUT 5. It is the direct connection to the source Power MOSFET switch No. 5. |
| 12 | CSN | Chip select not (active low). It is the selection pin of the device. It is a CMOS compatible input. |
| 13 | SCK | Serial clock. It is a CMOS compatible input. |
| 14 | SDI | Serial data input. Transfers data to be written serially into the device on SCK rising edge. |
| 15 | SDO | Serial data output. Transfers data serially out of the device on SCK falling edge. |
| 16 | VDD | DC supply input for the digital control part and SPI interface. 3.3 V and 5 V compatible, this is the input of the internal Voltage Regulator. |
| 11 | PWM_CLK | PWM external clock. The frequency of the internal PWM signal is divided according to the programmed ratio. It is possible to select one of the 4xPWM divider ratios: from 1/512 to 1/4096. |

2 Functional description

2.1 Device interfaces

- SPI: bi-directional interface, accessing RAM/ROM registers (CSN, SCK, SDI, SDO)
- DIx: input pins for outputs control while device is in Fail Safe mode, Standby mode or Reset mode (usable also in Normal mode according to "Direct Input Enable Control Register" - DIENCR, setting)
- V_{DD} : 5 V supply or 3.3 V supply. The internal regulator block which delivers internal logic supply voltage from V_{dd} input is able to handle both 3.3 V and 5 V.

2.2 Operating modes

The device can operate in seven different modes:

- Reset mode
- Fail-safe mode
- Normal mode
- Standby mode
- Sleep mode 1
- Sleep mode 2
- Battery undervoltage mode

The reset mode, the fail-safe mode and the sleep mode 1 are combined into the limp-home mode. In this mode the chip is able to operate without the connection to the SPI. All transitions between the states in limp-home mode are driven by V_{DD} and Dlx . The outputs are controlled by the direct inputs Dlx according to the internally programmed outputs assignment. By default, DIO drives $OUTPUT0,5$, $D11$ drives $OUTPUT1,2,3,4$.

Table 2. Operating modes

| Operating mode | Entering conditions | Leaving conditions | Characteristics |
|---|--|---|--|
| Startup transition (this is not an operating mode) | | <ul style="list-style-type: none"> • $V_{CC} > V_{USD}$: reset • ($V_{DD} > V_{DD_POR_ON}$) and ($V_{CC} > V_{USD}$): fail-safe | <ul style="list-style-type: none"> • Outputs: OFF • SPI: inactive • Registers: reset values • Diagnostics: not available • Reset bit = X |
| Reset (limp-home mode) | <ul style="list-style-type: none"> • Startup mode: $V_{CC} > V_{USD}$ • Sleep 1: • Dlx low to high • Any other mode: $V_{DD} < V_{DD_POR_OFF}$ | <ul style="list-style-type: none"> • All Dlx low: sleep 1 • $V_{DD} > V_{DD_POR_ON}$: fail-safe | <ul style="list-style-type: none"> • Outputs: according to Dlx • SPI: inactive • Registers: reset values • Diagnostics: not available • Reset bit = X |
| Sleep 1 (limp-home mode) | Reset: all $Dlx = 0$ | <ul style="list-style-type: none"> • $V_{DD} > V_{DD_POR_ON}$: fail-safe • Dlx low to high: reset | <ul style="list-style-type: none"> • Outputs: OFF • SPI: inactive • Registers: reset values • Diagnostics: not available • Low supply current from V_{CC} • Reset bit = X |
| Fail-safe (limp-home mode) | <ul style="list-style-type: none"> • Reset or sleep 1: $V_{DD} > V_{DD_POR_ON}$ • Standby or sleep 2: CSN low for $t > t_{stdby_out}$ • Normal: $EN = 0$ or $WDTB$ toggling timeout or SW-reset | <ul style="list-style-type: none"> • $V_{DD} < V_{DD_POR_OFF}$: reset • SPI sequence <ol style="list-style-type: none"> 1. UNLOCK = 1 2. GOSTBY = 0 and EN = 1: normal • SPI sequence <ol style="list-style-type: none"> 1. UNLOCK = 1 2. GOSTBY = 1 and EN = 0: standby | <ul style="list-style-type: none"> • Outputs: according to Dlx • SPI: active • Registers: read/write possible, cleared if entered after SW reset • Diagnostics: SPI possible, ADC conversion possible only in asynchronous mode • Reset bit = 1 if entered after SW reset or POR, else reset bit = 0 |
| Normal | <ul style="list-style-type: none"> • Fail-safe: SPI sequence <ol style="list-style-type: none"> 1. UNLOCK = 1 2. GOSTBY = 0 and EN = 1 | <ul style="list-style-type: none"> • $V_{DD} < V_{DD_POR_OFF}$: reset • SPI sequence <ol style="list-style-type: none"> 1. UNLOCK = 1 & EN = 1 2. GOSTBY = 1 and EN = 0: standby | <ul style="list-style-type: none"> • Outputs: according to SPI register settings and/or Dlx • SPI: active • Registers: read/write is possible • Diagnostics: SPI and ADC conversion in all modes (sampled and asynchronous) are possible |

| Operating mode | Entering conditions | Leaving conditions | Characteristics |
|--|--|---|---|
| | | <ul style="list-style-type: none"> EN = 0 or WDTB time-out or SW reset: fail-safe | <ul style="list-style-type: none"> Regular toggling of WDTB is necessary within timeout period t_{WDTB} Reset bit = 0 |
| Standby | <ul style="list-style-type: none"> Normal: SPI sequence <ol style="list-style-type: none"> UNLOCK = 1 & EN = 1 GOSTBY = 1 and EN = 0 Fail-safe: SPI sequence <ol style="list-style-type: none"> UNLOCK = 1 GOSTBY = 1 and EN = 0 Sleep 2: Dlx low to high | <ul style="list-style-type: none"> $V_{DD} < V_{DD_POR_OFF}$: reset CSN low for $t > t_{stdby_out}$: fail-safe All Dlx low: sleep 2 | <ul style="list-style-type: none"> Outputs: according to Dlx SPI: inactive Registers: frozen Diagnostics: not available Low supply current from V_{DD} CSN: High Reset bit = 0 |
| Sleep 2 | Standby: all Dlx = 0 | <ul style="list-style-type: none"> $V_{DD} < V_{DD_POR_OFF}$: reset CSN low for $t > t_{stdby_out}$: fail-safe Dlx low to high: standby | <ul style="list-style-type: none"> Outputs: OFF SPI: inactive Registers: frozen Diagnostics: not available Low supply current from V_{DD} and V_{CC} CSN: high Reset bit = 0 |
| Battery undervoltage (this is not an operating mode) | Any mode: $V_{CC} < V_{USD}$ | $V_{CC} > V_{USD} + V_{USDhyst}$: back to last mode | <ul style="list-style-type: none"> Outputs: OFF and independent from Dlx and SPI SPI: as the last mode Reset bit: as the last mode |

Figure 3. Device state diagram

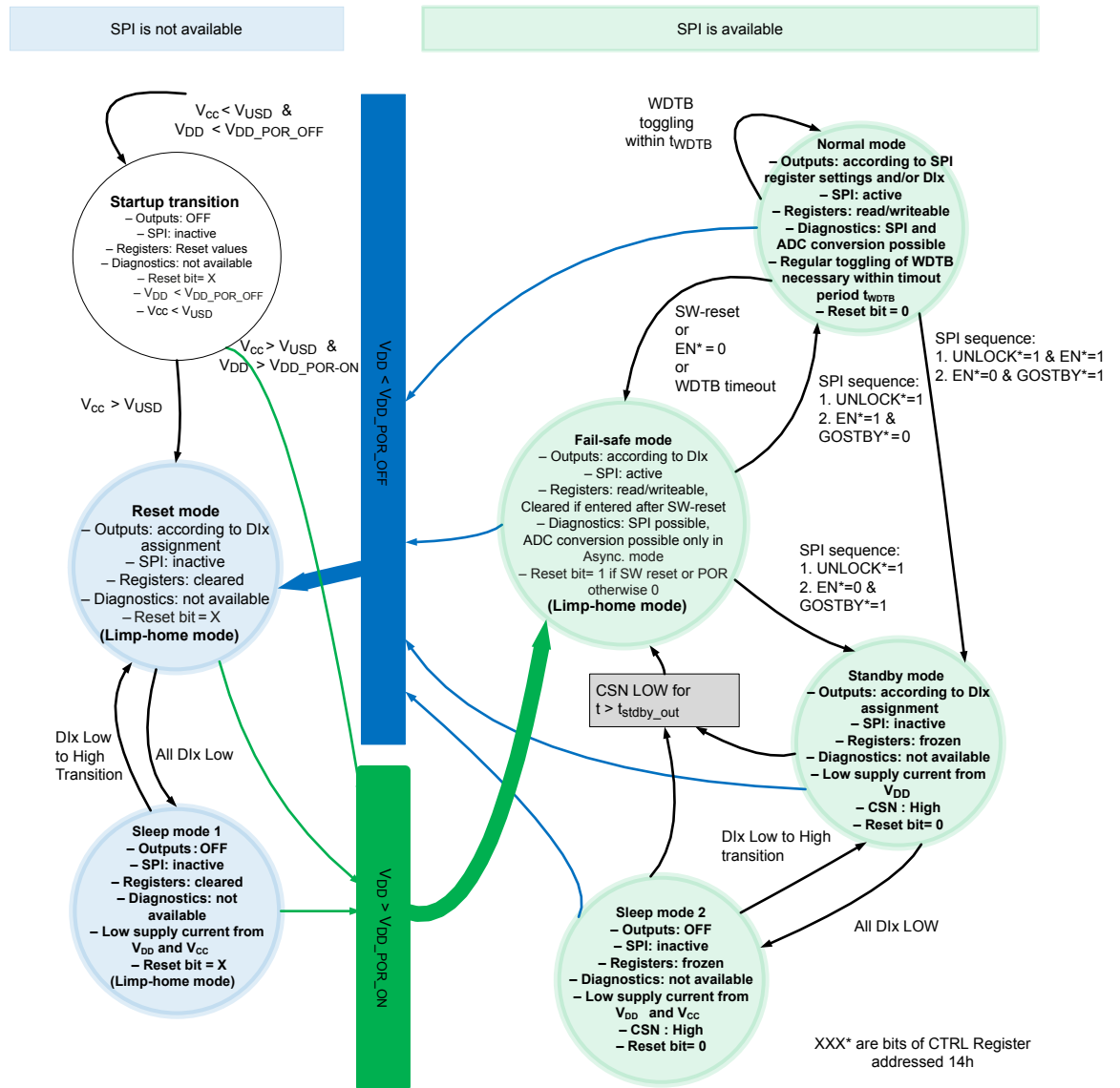

GADG0404170859FSR

For an overview on the operating modes and the triggering conditions please refer to [Section 2.2.9: Limp-home mode](#).

2.2.1 Startup transition phase

This is not an operation mode but a transition step to Reset operation mode from the power-ON. In this phase, neither digital supply voltage V_{DD} nor V_{CC} are available ($V_{DD} < V_{DD_POR_ON}$ and $V_{CC} < V_{USD}$).

This phase has not to be confused with Undervoltage mode where also the power supply is not available ($V_{CC} < V_{USD}$) after an operation mode. The device leaves this phase to Reset mode as soon as $V_{CC} > V_{USD}$. In case ($V_{CC} < V_{USD}$) but ($V_{DD} > V_{DD_POR_ON}$) then the device leaves this phase to Fail-Safe-Mode.

2.2.2 Reset mode

The device is in limp-home state.

Reset mode is entered after startup but also each time the digital supply voltage V_{DD} falls below $V_{DD_POR_OFF}$ ($V_{DD} < V_{DD_POR_OFF}$ and $V_{CC} > V_{USD}$).

The outputs are controlled by the direct inputs DIx according to internally programmed outputs assignment. At least one DIx is in logic high.

The SPI is inactive (no read/write possible) and the diagnostics are not available. The registers have the reset values.

The device leaves this mode only if $V_{DD} > V_{DD_POR_ON}$ or all DIx go low.

The reset bit inside the global status byte is unreadable since the SPI is inactive (for more information refer to [Section 4.3.1: Global Status byte description](#)).

The diagnostics is not available, but the protections are fully functional. In case of overtemperature or power limitation, the outputs work in unlimited autorestart.

The device enters reset mode under three conditions:

- Automatically during startup
- If it is in any other mode and if V_{DD} falls below $V_{DD_POR_OFF}$
- If it is in sleep mode 1, and if one input DIx is set to 1

The device exits reset mode under two conditions:

- If V_{DD} rises above $V_{DD_POR_ON}$, the device enters fail-safe mode
- If all inputs DIx are 0, the device enters sleep mode 1.

2.2.3 Fail-safe mode

The device is in limp-home state.

The digital supply voltage V_{DD} is available. ($V_{DD} > V_{DD_POR_ON}$) and the SPI registers are active (SPI read/write).

In fail-safe mode, the digital current sense is available only in asynchronous mode and the digital fault diagnostics is available through the SPI bus.

The outputs are controlled by the direct inputs DIx regardless of the SPI commands.

The registers are cleared to their reset value if fail-safe is entered through a software reset.

The reset bit is 1 if the last state was reset mode or the last command was a software reset and it is reset to 0 after the first SPI access (for more information refer to [Section 4.3.1: Global Status byte description](#)).

The protections are fully functional. In case of overtemperature or power limitation, the outputs work in unlimited autorestart.

The device exits fail-safe mode under five conditions:

- If it is in reset mode or in sleep mode 1 and V_{DD} rises above $V_{DD_POR_ON}$ ($V_{DD} > V_{DD_POR_ON}$)
- If it is in standby mode or in sleep mode 2 and CSN is low for $t > t_{stdby_out}$
- If it is in normal mode and bit EN is cleared
- If it is in normal mode and WDTB is not toggled within t_{WDTB} (watchdog timeout)
- If it is in normal mode and the SPI sends a software reset

The device exits fail-safe mode under three conditions:

- If the SPI sends the go to normal mode sequence, the device enters normal mode:
 - In a first communication set bit UNLOCK = 1
 - In the consecutive communication set bit GOSTBY = 0 and bit EN = 1

This mechanism avoids entering the normal mode unintentionally.

- If the SPI sends the go to standby mode sequence, the device enters standby mode:
 - In a first communication set bit UNLOCK = 1
 - In the consecutive communication set bit GOSTBY = 1 and bit EN = 0

This mechanism avoids entering the standby mode unintentionally.

- If V_{DD} falls below $V_{DD_POR_OFF}$, the device enters reset mode.

Transition to fail-safe mode from normal mode, using the SPI register

Only one frame is needed: Write "CTRL" 0x0001.

Table 3. Frame 1 (write CTRL 0x0001)

| | Bit 7 | Bit 6 | Bit 5 | Bit 4 | Bit 3 | Bit 2 | Bit 1 | Bit 0 |
|-------|----------|----------|----------|----------|----------|----------|----------|----------|
| CMD | OC1 | OC0 | Address | | | | | |
| | 0 | 0 | 0 | 1 | 0 | 1 | 0 | 0 |
| DATA1 | GOSTBY | UNLOCK | CTDTH1 | CTDTH0 | EN | Not used | Not used | Not used |
| | 0 | 0 | 0 | 0 | 0 | 0 | 0 | 0 |
| DATA2 | Not used | Not used | Lockbit3 | Lockbit2 | Lockbit1 | Lockbit0 | PWMSYNC | Parity |
| | 0 | 0 | 0 | 0 | 0 | 0 | 0 | 1 |

Transition to fail-safe mode from normal mode by software reset

SPI reset is occurring by using the "Read device information" command (applicable only on ROM area) at reserved ROM address 0x3F. This is the equivalent of sending a 0xFF command.

Only one frame is needed: read "ROM" 0x3F.

Table 4. Frame 1: read (ROM) 0x3F 0x--

| | Bit 7 | Bit 6 | Bit 5 | Bit 4 | Bit 3 | Bit 2 | Bit 1 | Bit 0 |
|-------|------------------|-------|---------|-------|-------|-------|-------|-------|
| CMD | OC1 | OC0 | Address | | | | | |
| | 1 | 1 | 1 | 1 | 1 | 1 | 1 | 1 |
| DATA1 | x ⁽¹⁾ | x | x | x | x | x | x | x |
| | 0 | 0 | 0 | 0 | 0 | 0 | 0 | 0 |
| DATA2 | x | x | x | x | x | x | x | x |
| | 0 | 0 | 0 | 0 | 0 | 0 | 0 | 0 |

1. X: do not care. At least one of these bits must be zero, as 0xFFFF frame is not allowed.

The entry to the fail-safe mode can occur due to the CSN timeout.

In this specific case, the following procedure must be executed to leave the fail-safe mode:

- Removing the cause of the CSN stuck
- Toggling the CSN pin for a min t_{SHCH} (time to release the SDO line), see parameter in [Table 48. Dynamic characteristics](#).
- Sending the SPI frames

If the above procedure is not respected, the first SPI frame is rejected and the state transition failed.

2.2.4 Normal mode

In this mode, all device functions are available. The transition to this mode is only possible from a previous fail-safe mode.

Outputs can be driven by SPI commands or a combination of SPI command and direct inputs Dlx.

To maintain the device in normal mode, the watchdog toggle bit in the register CONFIG has to be toggled within the watchdog timeout period t_{WDTB} (see [Table 48. Dynamic characteristics](#)).

Diagnosis and current sense are available through the SPI bus (digital).

The protections are fully functional. The outputs can be set to latch-off or programmable time-limited autorestart.

- In time-limited autorestart, the outputs are switched on again automatically after an overtemperature or power limitation event within the limited programmed time frame (refer to [Section 6.2: Blanking window values](#)).
- In latch mode, the relevant status register has to be cleared to switch the outputs on again (refer to [Section 6.2: Blanking window values](#)).

The device enters normal mode under one condition:

- If it is in fail-safe mode and the SPI sends the go to normal mode sequence:
 - In a first communication set bit UNLOCK = 1 – Write “CTRL” 0x4000;
 - In the consecutive communication set bit GOSTBY = 0 and bit EN = 1 – Write “CTRL” 0x8000;

Transition from fail-safe mode to normal mode is performed by two special SPI sequences.

- Frame 1: Write “CTRL” 0x4000
- Frame 2: Write “CTRL” 0x8000

Table 5. Frame 1 (Write CTRL 0x4000)

| | Bit 7 | Bit 6 | Bit 5 | Bit 4 | Bit 3 | Bit 2 | Bit 1 | Bit 0 |
|-------|----------|----------|----------|----------|----------|----------|----------|----------|
| CMD | OC1 | OC0 | Address | | | | | |
| | 0 | 0 | 0 | 1 | 0 | 1 | 0 | 0 |
| DATA1 | GOSTBY | UNLOCK | CTDTH1 | CTDTH0 | EN | Not used | Not used | Not used |
| | 0 | 1 | 0 | 0 | 0 | 0 | 0 | 0 |
| DATA2 | Not used | Not used | Lockbit3 | Lockbit2 | Lockbit1 | Lockbit0 | PWMSYNC | Parity |
| | 0 | 0 | 0 | 0 | 0 | 0 | 0 | 0 |

Table 6. Frame 2 (Write CTRL 0x8000)

| | Bit 7 | Bit 6 | Bit 5 | Bit 4 | Bit 3 | Bit 2 | Bit 1 | Bit 0 |
|-------|----------|----------|----------|----------|----------|----------|----------|----------|
| CMD | OC1 | OC0 | Address | | | | | |
| | 0 | 0 | 0 | 1 | 0 | 1 | 0 | 0 |
| DATA1 | GOSTBY | UNLOCK | CTDTH1 | CTDTH0 | EN | Not used | Not used | Not used |
| | 0 | 0 | 0 | 0 | 1 | 0 | 0 | 0 |
| DATA2 | Not used | Not used | Lockbit3 | Lockbit2 | Lockbit1 | Lockbit0 | PWMSYNC | Parity |
| | 0 | 0 | 0 | 0 | 0 | 0 | 0 | 0 |

The device exits normal mode under five conditions:

- If VDD falls below VDD_POR_OFF, the device enters reset mode.
- If the SPI sends the go to standby sequence, the device enters standby mode:
 - In a first communication set UNLOCK = 1
 - In the consecutive communication set GOSTBY = 1 and EN = 0

This mechanism avoids entering standby mode unintentionally.

- If the SPI clears the EN bit (EN = 0), the device enters fail-safe mode.
- Watchdog time out: If WDTB is not toggled within the monitoring timeout period t_{WDTB} , the device enters fail-safe mode.
- If the SPI sends a software reset command (command byte = 0xFFh), all registers are cleared and the device enters fail-safe mode.

2.2.5 Standby mode

The device is in the low consumption state of the digital part.

The outputs are controlled by the direct inputs Dlx only.

The current from V_{DD} is nearly 0.

The digital supply voltage V_{DD} is available ($V_{DD} > V_{DD_POR_ON}$) but the SPI is inactive (no read/write is possible, the SPI registers are frozen to their last state before entering standby mode).

During standby mode, the above conditions are kept if at least one Dlx in logic high.

The CSN is inactive in high state (independent of MCU).

The diagnostics is not available.

The protections are fully functional. The outputs are set to unlimited autorestart mode.

The device enters standby mode under three conditions:

- If it is in fail-safe mode and the SPI sends the go to standby sequence:
 - In a first communication set UNLOCK = 1
 - In the consecutive communication set GOSTBY = 1 and EN = 0
 This mechanism avoids entering standby mode unintentionally.
- If it is in normal mode and the SPI sends the go to standby sequence:
 - In a first communication set UNLOCK = 1
 - In the consecutive communication set GOSTBY = 1 and EN = 0
 This mechanism avoids entering standby mode unintentionally.
- If it is in sleep mode 2, and one input Dlx is set to one.

The device exits standby mode under three conditions:

- If V_{DD} falls below $V_{DD_POR_OFF}$, the device enters reset mode.
- If CSN is low for $t > t_{stdby_out}$, the device wakes up. As the device is in fail-safe mode, the outputs are controlled through Dlx pins, the ADC conversion is possible only in asynchronous mode and the digital diagnostics is available through the SPI bus.
- If all direct inputs Dlx are 0, the device enters sleep mode 2 resulting in minimal supply current from V_{CC} and V_{DD} .

Transition from fail-safe-mode to standby mode using SPI: two frames needed.

- Frame 1: write "CTRL" 0x4000
- Frame 2: write "CTRL" 0x8000

Table 7. Frame 1 (write CTRL 0x4000)

| | Bit 7 | Bit 6 | Bit 5 | Bit 4 | Bit 3 | Bit 2 | Bit 1 | Bit 0 |
|-------|----------|----------|----------|----------|----------|----------|----------|----------|
| CMD | OC1 | OC0 | Address | | | | | |
| | 0 | 0 | 0 | 1 | 0 | 1 | 0 | 0 |
| DATA1 | GOSTBY | UNLOCK | CTDTH1 | CTDTH0 | EN | Not used | Not used | Not used |
| | 0 | 1 | 0 | 0 | 0 | 0 | 0 | 0 |
| DATA2 | Not used | Not used | Lockbit3 | Lockbit2 | Lockbit1 | Lockbit0 | PWMSYNC | Parity |
| | 0 | 0 | 0 | 0 | 0 | 0 | 0 | 0 |

Table 8. Frame 2 (write CTRL 0x8000)

| | Bit 7 | Bit 6 | Bit 5 | Bit 4 | Bit 3 | Bit 2 | Bit 1 | Bit 0 |
|-------|----------|----------|----------|----------|----------|----------|----------|----------|
| CMD | OC1 | OC0 | Address | | | | | |
| | 0 | 0 | 0 | 1 | 0 | 1 | 0 | 0 |
| DATA1 | GOSTBY | UNLOCK | CTDTH1 | CTDTH0 | EN | Not used | Not used | Not used |
| | 1 | 0 | 0 | 0 | 0 | 0 | 0 | 0 |
| DATA2 | Not used | Not used | Lockbit3 | Lockbit2 | Lockbit1 | Lockbit0 | PWMSYNC | Parity |
| | 0 | 0 | 0 | 0 | 0 | 0 | 0 | 0 |

Transition from normal mode to standby mode using SPI: two frames needed

- Frame 1: write “CTRL” 0x4801
- Frame 2: write “CTRL” 0x8000

Table 9. Frame 2 (write CTRL 0x4801)

| | Bit 7 | Bit 6 | Bit 5 | Bit 4 | Bit 3 | Bit 2 | Bit 1 | Bit 0 |
|-------|----------|----------|----------|----------|----------|----------|----------|----------|
| CMD | OC1 | OC0 | Address | | | | | |
| | 0 | 0 | 0 | 1 | 0 | 1 | 0 | 0 |
| DATA1 | GOSTBY | UNLOCK | CTDTH1 | CTDTH0 | EN | Not used | Not used | Not used |
| | 0 | 1 | 0 | 0 | 1 | 0 | 0 | 0 |
| DATA2 | Not used | Not used | Lockbit3 | Lockbit2 | Lockbit1 | Lockbit0 | PWMSYNC | Parity |
| | 0 | 0 | 0 | 0 | 0 | 0 | 0 | 1 |

Table 10. Frame 2 (write CTRL 0x8000)

| | Bit 7 | Bit 6 | Bit 5 | Bit 4 | Bit 3 | Bit 2 | Bit 1 | Bit 0 |
|-------|----------|----------|----------|----------|----------|----------|----------|----------|
| CMD | OC1 | OC0 | Address | | | | | |
| | 0 | 0 | 0 | 1 | 0 | 1 | 0 | 0 |
| DATA1 | GOSTBY | UNLOCK | CTDTH1 | CTDTH0 | EN | Not used | Not used | Not used |
| | 1 | 0 | 0 | 0 | 0 | 0 | 0 | 0 |
| DATA2 | Not used | Not used | Lockbit3 | Lockbit2 | Lockbit1 | Lockbit0 | PWMSYNC | Parity |
| | 0 | 0 | 0 | 0 | 0 | 0 | 0 | 0 |

2.2.6 Sleep mode 1

The device is in limp-home state.

The device has very low consumption for both digital and power parts. Current consumption from the digital part is nearly zero and the current consumption on V_{CC} is supply current in sleep mode 1.

The digital supply voltage V_{DD} is not available ($V_{DD} < V_{DD_POR_OFF}$) and SPI is inactive (the read and write functions are not possible and all registers are cleared and have the reset values).

- The diagnostics is not available.
- The output stages are all off.
- Protections are inactive.

The device enters sleep mode 1 under one condition:

- If from reset mode, all direct inputs Dlx are going low.

The device exits sleep mode 1 under two conditions:

- If V_{DD} rises above $V_{DD_POR_ON}$, the device enters fail-safe mode.
- If one of the inputs Dlx is set to 1, the device enters reset mode.

2.2.7 Sleep mode 2

The device is in very low consumption state for both digital and power parts. Current consumption from the digital part is I_{DDstd} and the current consumption on V_{CC} is supply current in sleep mode 2.

The digital supply voltage V_{DD} is available ($V_{DD} > V_{DD_POR_ON}$) but SPI is not active (the read and write functions are not possible and all registers are frozen).

The CSN is in inactive high state (independent of MCU).

In sleep mode 2 the following limitations must be considered:

- The diagnostics is not available
- The output stages are all off
- Protections are inactive

The device enters sleep mode 2 under one condition:

- If from standby mode, all direct inputs Dlx are going low

Sleep mode 2 can be left with three conditions:

- If V_{DD} falls below $V_{DD_POR_OFF}$, the device enters reset mode
- If CSN is low for $t > t_{stdby_out}$, the device enters fail-safe mode
- If one of the inputs Dlx is set to 1, the device enters standby mode

2.2.8 Battery undervoltage mode

This is not an operation mode but a transition step, where the power supply voltage is ($V_{CC} < V_{USD}$).

If the battery supply voltage V_{CC} falls below the undervoltage shutdown threshold ($V_{CC} < V_{USD}$) the device enters battery undervoltage mode.

The CurrentSense diagnostics is not available. The output stages are off regardless of SPI status or Dlx .

Three different cases occur, depending on the operating mode:

1. From normal mode and from fail-safe mode:

In this mode, the digital supply voltage V_{DD} is available ($V_{DD} > V_{DD_POR_ON}$). The SPI is active and read/write functions are possible. The SPI diagnostics is available. After entering the undervoltage mode, the information about the undervoltage is saved in a flag (VCCUV) in the OUTSRx register, the SPI register contents are retained. The SPI-register reading is always possible.

If V_{CC} rises above the threshold ($V_{USD} + V_{USDhyst}$) the device returns to the last mode and the flag is cleared (VCCUV).

If during this state V_{DD} decreases to $V_{DD} < V_{DD_POR_OFF}$, the device is reset completely. The last operation mode information is lost. The device logic part is unpowered, therefore after increasing the supply voltage to ($V_{CC} > V_{USD} + V_{USDhyst}$) the operation mode is the reset mode.

If during this state the Dlx is changed, the operation mode is not changed and the output state is changed accordingly after V_{CC} recovering.

2. From standby and sleep mode-2 modes:

In this mode, the digital supply voltage V_{DD} is available ($V_{DD} > V_{DD_POR_ON}$). The SPI is not active and the registers are frozen. The SPI diagnostics is not available. After entering the undervoltage mode, the information about the undervoltage is not saved in a flag (VCCUV).

If V_{CC} rises above the threshold ($V_{USD} + V_{USDhyst}$) the device returns to the last mode. If during this state (undervoltage mode) V_{DD} decreases to $V_{DD} < V_{DD_POR_OFF}$, the device is reset completely. The last operation mode information is lost. The device logic part is unpowered, therefore after increasing the supply voltage to ($V_{CC} > V_{USD} + V_{USDhyst}$) the operation mode is the reset mode.

If during this state (under voltage mode) the Dlx is changed, the operation mode is also changed. After V_{CC} recovering, this new operation mode is taken into account.

3. From reset mode or Sleep-mode1:

In this mode, the digital supply voltage V_{DD} is not available ($V_{DD} < V_{DD_POR_OFF}$) and the SPI is not active. It is not possible to read/write via SPI all SPI registers have the reset values. After entering the undervoltage mode, the information about the undervoltage is not saved in a flag (VCCUV).

If V_{CC} rises above the threshold $V_{USD} + V_{USDhyst}$, the device returns to the last mode. If during this state V_{DD} increases to $V_{DD} > V_{DD_POR_ON}$, the device is completely reset. After V_{CC} recovering ($V_{CC} > V_{USD} + V_{USDhyst}$), there will be a startup transition.

The undervoltage flag (VCCUV) is not saved in the following operation modes:

- Reset mode
- Sleep mode 1
- Sleep mode 2
- Standby mode

Figure 4. Battery undervoltage shutdown diagram

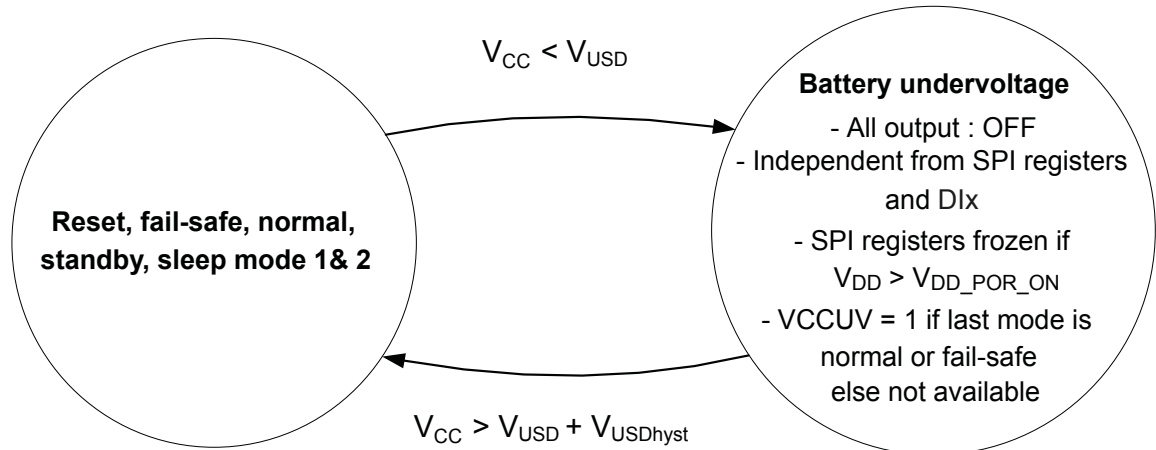

GADG0404171125PS

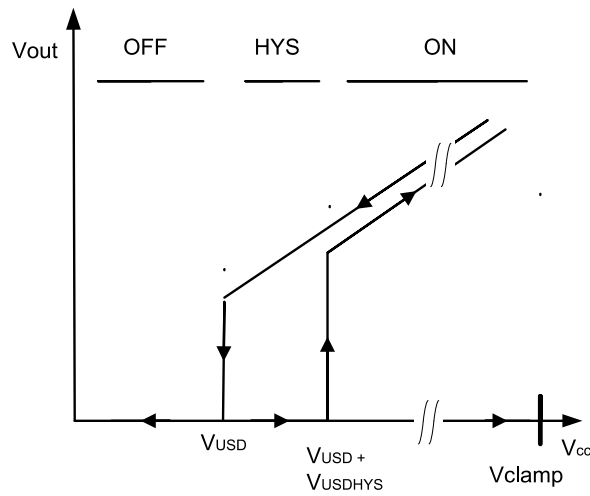
Figure 5. Undervoltage shutdown

GADG311020171209MT

2.2.9 Limp-home mode

The reset mode, the fail-safe mode, and the sleep mode 1 are combined into the limp-home mode. In this mode, the chip is able to operate without the connection to the SPI. All transitions between the states in limp home mode are driven by VDD and Dlx. The outputs are controlled by the direct inputs Dlx.

The Dlx inputs can be driven by either a μC I/O port or directly by KL15 (12 V) through series resistance. Each output has an OTP programmed direct input assignment for limp home operation. Any output can be programmed to be always OFF in the limp-home, or according to DI0 pin state or according to DI1 pin state.

Default configuration is:

- DI0 drivers OUT 0, 5
- DI1 drivers OUT 1, 2, 3, 4

For a direct entry to the limp-home mode during normal operating mode, the MCU uses the watchdog toggle bit (WDTB) or a dedicated SPI command. Changing the polarity of the WDTB within watchdog timeout (t_{WDTB}) keeps the device in normal mode.

3 Protections

3.1 Pre-warning

If the case-temperature rises above the case-thermal detection pre-warning threshold T_{CSD} , the bit T_{CASE} in the Global Status Byte is set. T_{CASE} is cleared automatically when the case-temperature drops below the case-temperature reset threshold T_{CR} .

3.2 Junction overtemperature (OT)

If the junction temperature of one channel rises above the shutdown temperature T_{TSD} , an overtemperature event (OT) is detected.

The channel is switched OFF and the corresponding bit in the address OUTSRx register - channel feedback status register (CHFBSRx) is set. Consequently, the thermal shutdown bit (bit 4) in the global status byte and the global error flag are set.

Each output channel can be either set as latch-off or programmable time-limited autorestart operations in case of junction overtemperature event.

- In latched OFF operating mode, the output is switched OFF and the corresponding bit "CHLOFFSRx" in the OUTSRx register is set. If, after a time $>t_{D_Restart}$, the junction temperature falls below TRS and a write command to the addressed latched OFF channel is sent (CHLOFFTCRx) the output switches ON again automatically. The action clears the corresponding bit "CHLOFFSRx" in the OUTSRx register and bit 4 in the global status byte. Bit 4 only remains stuck at logic high if another fault condition is present at the same time.
- In time limited auto-restart operating mode, if $t_{blanking} < t_{D_Restart}$ see [Figure 33. Normal mode - Short circuit – PBW < \$t_{D_Restart}\$](#) , during the programmed time, the output is switched off as described and after $t_{D_Restart}$ switches ON again automatically, when the junction temperature falls below the reset temperature TRS. If the junction temperature is still above T_{TSD} after $t_{blanking}$, channel is latched OFF and the corresponding bit "CHLOFFSRx" in the OUTSRx register is set with bit 4 in the global status byte.

If $t_{blanking} > t_{D_Restart}$ see [Figure 34. Normal mode - Short circuit – PBW > \$t_{D_Restart}\$](#) , the output is switched OFF as described and switches ON again automatically, when the junction temperature falls below the reset temperature TRS. If junction temperature is still above T_{TSD} after $t_{D_Restart}$, the channel is latched OFF and the corresponding bit "CHLOFFSRx" in the OUTSRx register is set with bit 4 in the global status byte.

3.3 Power limitation (PL)

If the difference between junction temperature and case temperature ($\Delta T = T_J - T_C$) rises above the power limitation threshold ΔT_{PLIM} , a power limitation event is detected.

The corresponding bit in the OUTSRx register - channel feedback status bit (CHFBSR) is set. The channel is switched OFF and therefore the bit 4 in the global status byte is set.

Each output channel can be either set as latch-off or as programmable time-limited autorestart operations in case of the power limitation event.

- In latched OFF operation, the output remains switched OFF and the corresponding bit "CHLOFFSRx" in the OUTSRx register is set, until the junction temperature falls below T_R and a write command to the addressed latched OFF channel is sent (CHLOFFTCRx). The action clears the corresponding bit "CHLOFFSRx" in the OUTSRx register and bit 4 in the global status byte. Bit 4 only remains stuck at logic high if another fault condition is present at the same time.
- In time-limited auto restart, during the programmed time, the output is switched off as described and switches on again automatically when the difference of junction temperature and case temperature ($\Delta T = T_J - T_C$) decreases below ΔT_R . The status bit "CHLOFFSR" is latched during the OFF-state of the channel in order to allow asynchronous diagnostics and it is automatically cleared when the difference of junction temperature and case temperature ($\Delta T = T_J - T_C$) decreases below ΔT_{RS} . After the programmed time expiration, the output remains switched OFF and acts as the latch-off mode described above.

4 SPI functional description

4.1 SPI communication

The SPI communication is based on a standard ST-SPI 24-bit interface, using CSN, SDI, SDO and SCK signal lines.

Input data are shifted into SDI, MSB first while output data are shifted out on SDO, MSB first.

4.1.1 Signal description

During all operations, V_{DD} must be held stable and within the specified valid range: V_{DD} min to V_{DD} max.

Table 11. SPI signal description

| Name | Function |
|------------------------|--|
| Serial clock SCK | This input signal provides the timing of the serial interface. Data present at Serial Data Input (SDI) are latched on the rising edge of Serial Clock (SCK). Data on Serial Data Output (SDO) change after the falling edge of Serial Clock (SCK). |
| Serial data input SDI | This input signal is used to transfer data serially into the device. It receives data to be written. Values are sampled on the rising edge of Serial Clock (SCK). |
| Serial data output SDO | This output signal is used to transfer data serially out of the device. Data are shifted out on the falling edge of Serial Clock (SCK). |
| Chip select CSN | <p>When this input signal is High, the device is deselected and Serial Data Output (SDO) is high impedance. Driving this input Low enables the communication. The communication must start on a Low level of Serial Clock (SCK). Data are accepted only if exactly bits (or 8 bits Short Frame option) have been shifted in.</p> <p>Note: as per the ST_SPI standard, in case of failing communication:</p> <ul style="list-style-type: none"> • CSN Stuck @HIGH: <ul style="list-style-type: none"> – If the device is in Normal Mode, a WDTB Timeout will force the device into Fail-safe mode. The Serial Data-Out (SDO) will stay in High impedance (High Z). Any valid communication arrived after this event will be accepted by the device. • CSN Stuck @LOW: <ul style="list-style-type: none"> – in this case and whatever the mode of the device, a CSN Timeout protection will be activated and force the device to release the SPI bus. Then the Serial Data-Out (SDO) will go into High impedance (High Z). <p>A reset of the CSN Timeout (described as t_{SHCH} parameter in Table 48. Dynamic characteristics) is activated with a transition Low to High on CSN pin (or with a Power On Reset or Software reset). With this reset, the Serial Data-Out (SDO) will be released and any valid communication will be accepted by the device. Without this reset, next communication will not be taken into account by the device.</p> |

4.1.2 Connecting to the SPI bus

A schematic view of the architecture between the bus and devices can be seen in [Figure 7. Bus master and two devices in a normal configuration](#).

All input data bytes are shifted into the device, MSB first. The Serial Data Input (SDI) is sampled on the first rising edge of the Serial Clock (SCK) after Chip Select (CSN) goes low. All output data bytes are shifted out of the device on the falling edge of SCK, MSB first on the first falling edge of the Chip Select (CSN).

4.1.3 SPI mode

Supported SPI mode during a communication phase can be seen in the following figure:

Figure 6. Supported SPI mode

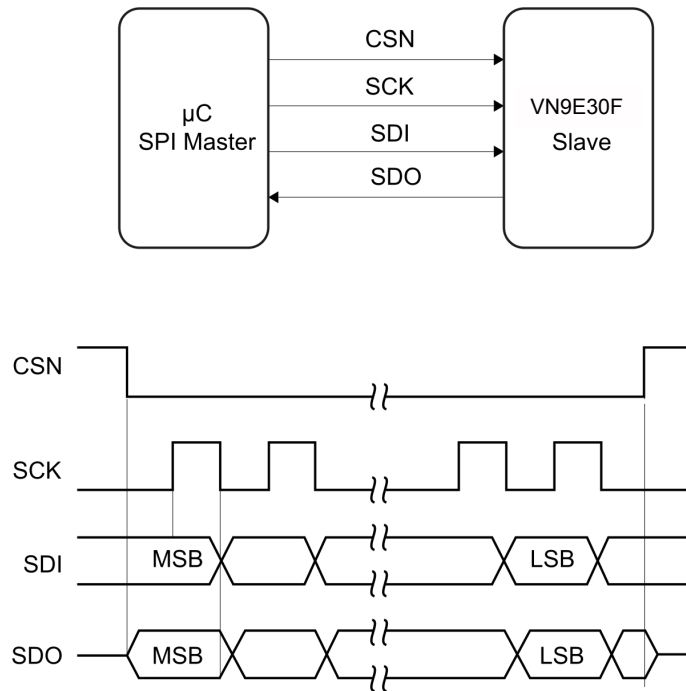

GADG010320191255MT

This device can be driven by a microcontroller with its SPI peripheral running in the following mode:

- CPOL = 0, CPHA = 0

Figure 7. Bus master and two devices in a normal configuration

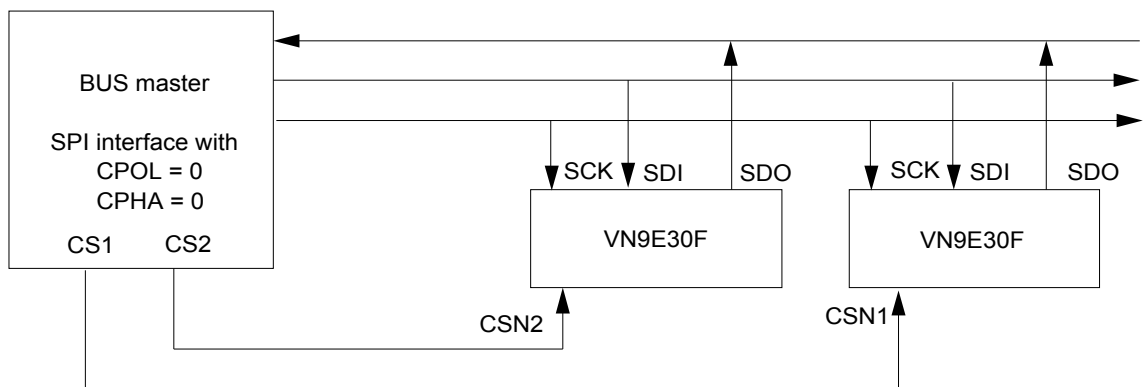

GADG010320191301MT

4.2 SPI protocol

4.2.1 SDI, SDO format

SDI format during each communication frame starts with a command byte. It begins with two bits of operating code (OC0, OC1) which specify the type of operation (read, write, read and clear status, read device information) and it is followed by a 6 bit address (A0:A5). The command byte is followed by two input data bytes (D15:D8) and (D7:D0).

Table 12. Command byte

| MSB | Bit 6 | Bit 5 | Bit 4 | Bit 3 | Bit 2 | Bit 1 | LSB |
|-----|-------|-------|-------|-------|-------|-------|-----|
| OC1 | OC0 | A5 | A4 | A3 | A2 | A1 | A0 |

Table 13. Input data byte 1

| MSB | Bit 6 | Bit 5 | Bit 4 | Bit 3 | Bit 2 | Bit 1 | LSB |
|-----|-------|-------|-------|-------|-------|-------|-----|
| D15 | D14 | D13 | D12 | D11 | D10 | D9 | D8 |

Table 14. Input data byte 2

| MSB | Bit 6 | Bit 5 | Bit 4 | Bit 3 | Bit 2 | Bit 1 | LSB |
|-----|-------|-------|-------|-------|-------|-------|-------------------|
| D7 | D6 | D5 | D4 | D3 | D2 | D1 | D0 ⁽¹⁾ |

1. D0 is the parity bit.

SDO format during each communication frame starts with a specific byte called Global Status Byte (see [Table 22. Global status byte](#) for more details of bit0-bit7). This byte is followed by two output data bytes (D15:D8) and (D7:D0).

Table 15. Global status byte

| MSB | Bit 6 | Bit 5 | Bit 4 | Bit 3 | Bit 2 | Bit 1 | LSB |
|------|-------|-------|-------|-------|-------|-------|------|
| bit7 | bit6 | bit5 | bit4 | bit3 | bit2 | bit1 | bit0 |

Table 16. Output data byte 1

| MSB | Bit 6 | Bit 5 | Bit 4 | Bit 3 | Bit 2 | Bit 1 | LSB |
|-----|-------|-------|-------|-------|-------|-------|-----|
| D15 | D14 | D13 | D12 | D11 | D10 | D9 | D8 |

Table 17. Output data byte 2

| MSB | Bit 6 | Bit 5 | Bit 4 | Bit 3 | Bit 2 | Bit 1 | LSB |
|-----|-------|-------|-------|-------|-------|-------|-----|
| D7 | D6 | D5 | D4 | D3 | D2 | D1 | D0 |

4.2.2 Operating code definition

The SPI interface features four different addressing modes which are listed in Table 18. Operating codes.

Table 18. Operating codes

| OC1 | OC0 | Meaning |
|-----|-----|---------------------------------|
| 0 | 0 | Write operation |
| 0 | 1 | Read operation |
| 1 | 0 | Read and clear status operation |
| 1 | 1 | Read device information |

Write mode

The write mode of the device allows to write the content of the input data byte into the addressed register (see list of registers in Table 23. RAM memory map). Incoming data are sampled on the rising edge of the serial clock (SCK), MSB first.

During the same sequence outgoing data are shifted out MSB first on the falling edge of the CSN pin and subsequent bits on the falling edge of the serial clock (SCK). The first byte corresponds to the Global Status Byte and the second to the previous content of the addressed register.

Figure 8. SPI write operation

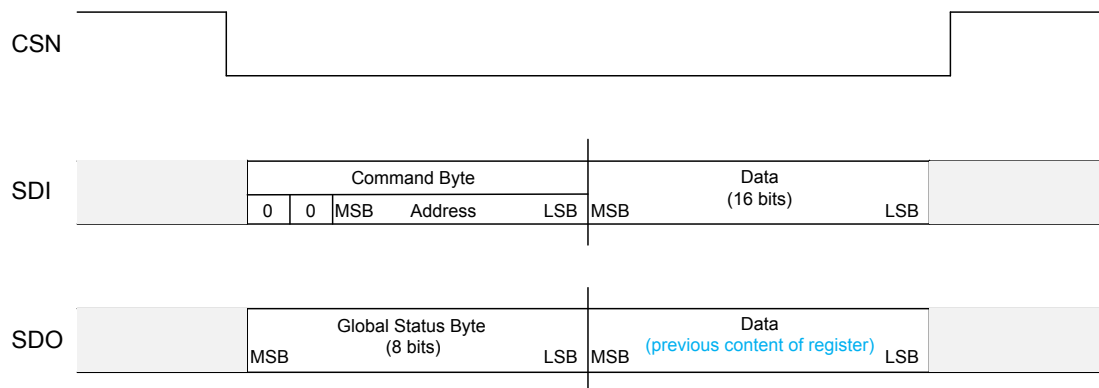

GADG311020171214MT

Read mode

The read mode of the device allows to read and to check the state of any register.

Incoming data are sampled on the rising edge of the serial clock (SCK), MSB first.

The command byte allows to determine which register content is read, whilst the others two data bytes are "don't care".

In case of a read mode on an unused address, the global status/error byte on the SDO pin is followed by 0x0000 word.

In order to avoid inconsistency between the Global Status byte and the Status register, the Status register contents are frozen during SPI communication.

Figure 9. SPI read operation

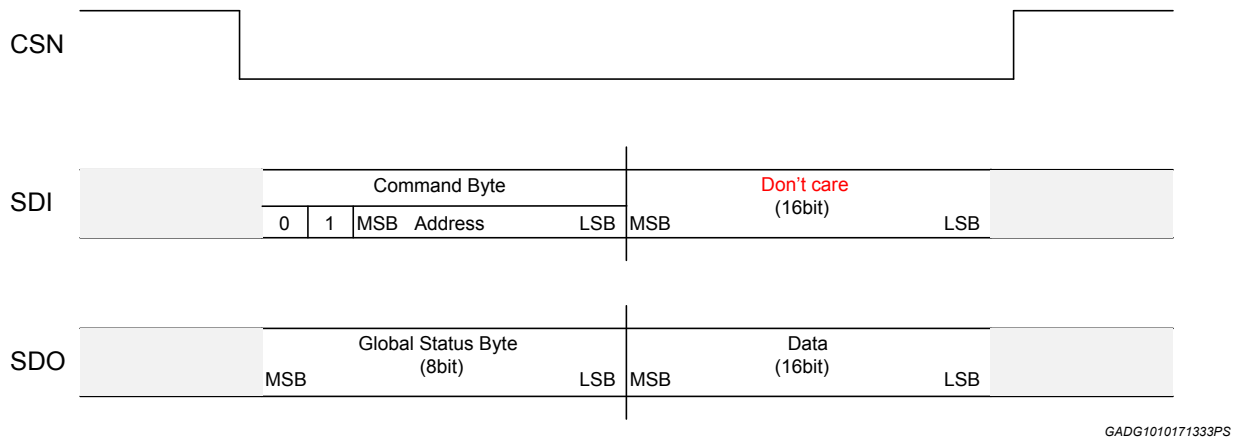

Read and clear status command

The read and clear status operation is used to clear the content of the addressed status register (see [Table 23. RAM memory map](#)). A read and clear status operation with address 0x3Fh clears all Status registers simultaneously.

Incoming data are sampled on the rising edge of the serial clock (SCK), MSB first. The command byte allows to determine which register content is read and the payload bits set to 1 into the data byte determine the bits into the register which have to be cleared.

Outgoing data are shifted out MSB first on the falling edge of the CSN pin and others on the falling edge of the serial clock (SCK). The first byte corresponds to the Global Status byte and the second to the content of the addressed register.

In order to avoid inconsistency between the Global Status byte and the Status register, the Status register contents are frozen during SPI communication.

Figure 10. SPI read and clear operation

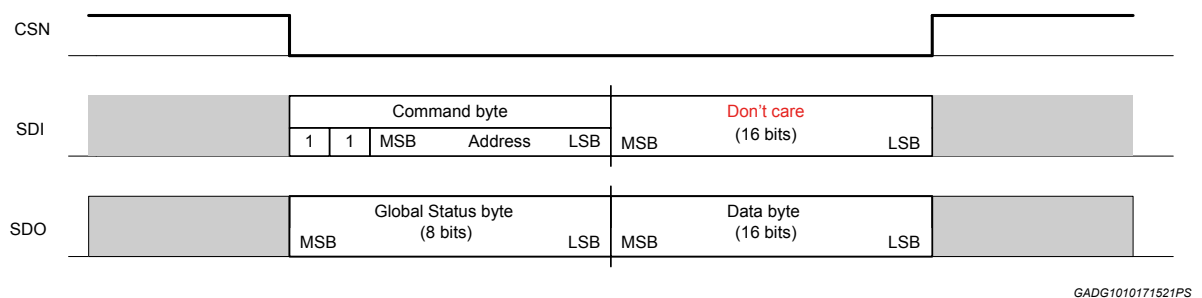

Read device information

Specific information can be read but not modified during this mode. Accessible data can be seen in [Table 24. ROM memory map](#).

Incoming data are sampled on the rising edge of the serial clock (SCK), MSB first. The command byte allows to determine which information is read whilst the other two data bytes are "don't care".

Outgoing data are shifted out MSB first on the falling edge of the CSN pin and others on the falling edge of the serial clock (SCK). The first byte corresponds to the Global Status byte and the second to the content of the addressed register and third byte is 0x00.

Note: ROM is based on 8-bit registers, then even if 16-bit are returned, only the second byte contains the addressed ROM register.

Figure 11. SPI read device information

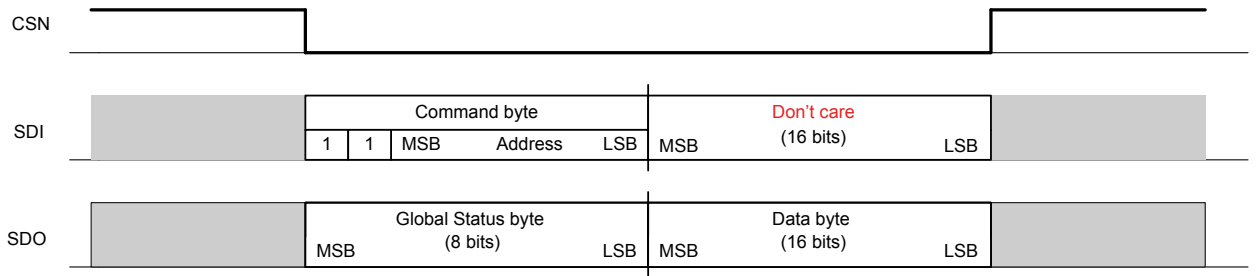

GADG1010171521PS

4.2.3 Special commands

0xFF - SW-Reset: set all control registers to default

An OpCode '11' (read device information) addressed at '111111' forces a Software Reset of the device, second and third bytes are "don't care" provided that at least one bit is zero.

Note: An OpCode '11' at address '111111' with data field equal to '1111111111111111' the SPI frame is recognized as a frame error and SPIE bit of GSB is set.

Table 19. 0xFF: SW_Reset

| Bit 7 | Bit 6 | Bit 5 | Bit 4 | Bit 3 | Bit 2 | Bit 1 | Bit 0 |
|---------|------------------|---------|-------|-------|-------|-------|-------|
| Command | | | | | | | |
| OC1 | OC0 | Address | | | | | |
| 1 | 1 | 1 | 1 | 1 | 1 | 1 | 1 |
| DATA1 | X ⁽¹⁾ | X | X | X | X | X | X |
| | 0 | 0 | 0 | 0 | 0 | 0 | 0 |
| DATA2 | X | X | X | X | X | X | X |
| | 0 | 0 | 0 | 0 | 0 | 0 | 0 |

1. X: do not care.

0xBF - clear all status registers (RAM access)

When an OpCode '10' (read and clear operation) at address b'111111 is performed.

Table 20. Clear all status registers (RAM access)

| Bit 7 | Bit 6 | Bit 5 | Bit 4 | Bit 3 | Bit 2 | Bit 1 | Bit 0 |
|---------|------------------|---------|-------|-------|-------|-------|-------|
| Command | | | | | | | |
| OC1 | OC0 | Address | | | | | |
| 1 | 0 | 1 | 1 | 1 | 1 | 1 | 1 |
| DATA1 | X ⁽¹⁾ | X | X | X | X | X | X |
| | 0 | 0 | 0 | 0 | 0 | 0 | 0 |
| DATA2 | X | X | X | X | X | X | X |
| | 0 | 0 | 0 | 0 | 0 | 0 | 0 |

1. X: do not care.

Note: Reset value = the value of the register after a power on.
 Default value = the default value of the register. Currently this is equivalent to the Reset value.
 Cleared register = explicitly read and clear of the register, if it is not write protected.

4.3 Register map

The device contains a set of RAM registers used for device configuration, the device status and ROM registers for device identification. Since ST-SPI is used, the Global Status byte defines the device status, containing fault information.

4.3.1 Global Status byte description

The data shifted out on SDO during each communication starts with a specific byte called Global Status Byte. This one is used to inform the microcontroller about global faults which can happen at channel-side level (i.e. like thermal shutdown, OLOFF...) or on the SPI interface (like Watchdog monitoring timeout event, communication error,...). This specific register has the following format:

Table 21. Global Status Byte (GSB)

| MSB | | | | | | LSB | |
|------|------|------|-----------|-------------------|------------------|-------------------|----|
| GSBN | RSTB | SPIE | TSD/OTOVL | T _{CASE} | L _{OFF} | O _{LOFF} | FS |

Table 22. Global status byte

| Bit | Name | Reset | Content |
|-----|---|-------|--|
| 7 | Global Status Bit Not | 0 | The GSBN is a logically NOR combination of Bit 0 to Bit 6. This bit can also be used as Global Status Flag without starting a complete communication frame as it is present directly after pulling CSN low. |
| 6 | Reset bit | 1 | The RSTB indicates a device reset. In case this bit is set, all internal Control Registers are set to default and kept in that state until the bit is cleared. The Reset bit is automatically cleared by any valid SPI communication |
| 5 | SPI Error | 0 | The SPIE is a logical OR combination of errors related to a wrong SPI communication (SCK count and SDI stuck at errors). The SPIE bit is automatically set when SDI is stuck at High or Low. The SPIE is automatically cleared by a valid SPI communication. |
| 4 | Thermal shutdown (OT) or Power limitation (PL) or VDS | 0 | This bit is set in case of thermal shutdown, power limitation or in case of high VDS (VDS) at turn-off detected on any channel. The contribution of high VDS failure is maskable. |
| 3 | T _{CASE} | 0 | This bit is set if the frame temperature is greater than the threshold and can be used as a temperature pre-warning. The bit is cleared automatically when the frame temperature drops below the case-temperature reset threshold (TCR). |
| 2 | Latch OFF (LOFF) | 0 | The Device Error bit is set in case when one or more channels are latched OFF |
| 1 | Open-load at off-state or output shorted to V _{CC} (OLOFF) | 0 | The Open-load at off state bit is set when an Open-load off state or an Output shorted to V _{cc} condition is detected on any channel |
| 0 | FailSafe | 1 | The bit is set in case device operates in Fail Safe Mode. A detailed description of these root-causes and the <i>Fail Safe State</i> itself is specified in the paragraph " <i>Fail Safe Mode</i> " |

Note: *The FFh or 00h combinations for the Global Status Byte are not possible, due to the active low of global status bit (bit 7), exclusive combination exists between bit 7 and bit 0 - bit 6. Consequently a FFh or 00h combination for the Global Status Byte must be detected by the microcontroller as a failure (SDO stuck to GND or to V_{DD} or loss of SCK).*

4.3.2 RAM

RAM registers can be separated according to the frequency of usage:

- Init: the register is read/written during the initialization phase (single shot action)
- Continuous: the read/write/read and clear registers often accessed, applying outputs control and diagnostics
- Rare: the read/read and clear status of device registers accessed on demand (in case of failure)

Table 23. RAM memory map

| Address | Name | Access | Content | Access type | Reset value |
|--------------------------|------------|------------|--|-------------|-------------|
| CONTROL REGISTERS | | | | | |
| 00h | OUTCTRCR0 | Read/Write | Output control configuration register channel 0 | Init | 0x0000 |
| 01h | OUTCTRCR1 | Read/Write | Output control configuration register channel 1 | Init | 0x0000 |
| 02h | OUTCTRCR2 | Read/Write | Output control configuration register channel 2 | Init | 0x0000 |
| 03h | OUTCTRCR3 | Read/Write | Output control configuration register channel 3 | Init | 0x0000 |
| 04h | OUTCTRCR4 | Read/Write | Output control configuration register channel 4 | Init | 0x0000 |
| 05h | OUTCTRCR5 | Read/Write | Output control configuration register channel 5 | Init | 0x0000 |
| 08h | OUTCFGR0 | Read/Write | Output configuration register 0 | Init | 0x0000 |
| 09h | OUTCFGR1 | Read/Write | Output configuration register 1 | Init | 0x0000 |
| 0Ah | OUTCFGR2 | Read/Write | Output configuration register 2 | Init | 0x0000 |
| 0Bh | OUTCFGR3 | Read/Write | Output configuration register 3 | Init | 0x0000 |
| 0Ch | OUTCFGR4 | Read/Write | Output configuration register 4 | Init | 0x0000 |
| 0Dh | OUTCFGR5 | Read/Write | Output configuration register 5 | Init | 0x0000 |
| 10h | CHLOFFTCR0 | Read/Write | Channel latch-off timing control register 1 (channels 5, 4, 3) | Init | 0x0000 |
| 11h | CHLOFFTCR1 | Read/Write | Channel latch-off timing control register 0 (channels 2, 1, 0) | Init | 0x0000 |
| 13h | SOCCR | Read/Write | Channel control register | Init | 0x0000 |
| 14h | CTRL | Read/Write | Control register | Init | 0x0000 |
| ... not used area | | | | | |
| STATUS REGISTERS | | | | | |
| 20h | OUTSR0 | Read/Clear | Output status register channel 0 | Rare | 0x0000 |
| 21h | OUTSR1 | Read/Clear | Output status register channel 1 | Rare | 0x0000 |
| 22h | OUTSR2 | Read/Clear | Output status register channel 2 | Rare | 0x0000 |
| 23h | OUTSR3 | Read/Clear | Output status register channel 3 | Rare | 0x0000 |
| 24h | OUTSR4 | Read/Clear | Output status register channel 4 | Rare | 0x0000 |
| 25h | OUTSR5 | Read/Clear | Output status register channel 5 | Rare | 0x0000 |
| 28h | ADC0SR | Read | Digital current sense channel 0 | Continuous | 0x0000 |
| 29h | ADC1SR | Read | Digital current sense channel 1 | Continuous | 0x0000 |
| 2Ah | ADC2SR | Read | Digital current sense channel 2 | Continuous | 0x0000 |
| 2Bh | ADC3SR | Read | Digital current sense channel 3 | Continuous | 0x0000 |
| 2Ch | ADC4SR | Read | Digital current sense channel 4 | Continuous | 0x0000 |
| 2Dh | ADC5SR | Read | Digital current sense channel 5 | Continuous | 0x0000 |
| 31h | ADC9SR | Read | Digital frame temperature sense | Continuous | 0x0000 |

Note: Any command (write, read, or read and clear status) executed on a “not used” RAM register, that is, a not assigned address, has no effect: there is no change in the global status byte (no communication error, no error flag). The data written to this address is ignored. The data read from this address contains 0000h, independent of what has been written previously to this address.

A write command on “don’t care” bits of an assigned RAM register address has no effect: there is no change on the global status byte. The data written to the “don’t care bits” is ignored. The content of the “don’t care bits” remains at “0” independent of the data written to these bits.

4.3.3 ROM

This memory is used for device identification.

Table 24. ROM memory map

| Address | Name | Description | Access | Content |
|-------------------|-------------------|--|-----------|---------|
| 00h | Company code | Indicates the code of STM company | Read only | 00H |
| 01h | Device Family | Indicates the product family | Read only | 01H |
| 02h | Product Code 1 | Indicates the first code of the product | Read only | 58H |
| 03h | Product Code 2 | Indicates the 2nd code of the product | Read only | 56H |
| 04h | Product Code 3 | Indicates the third code of the product | Read only | 5B |
| 0Ah | Version | Silicon version | Read only | 03H |
| ... not used area | | | | |
| 10h | SPI Mode | Different Modes of the SPI (see Section 4.3.4: SPI modes) | Read only | A1H |
| 11h | WD Type 1 | Indicates the type of WatchDog used in the product | Read only | 46H |
| 13h | WD bit position 1 | Indicates the address of the register containing the WD toggle bit | Read only | 40H |
| 14h | WD bit position 2 | Indicates the position of the WD toggle bit | Read only | C1H |
| ... not used area | | | | |
| 20h | SPI CPHA | Indicates the polarity and phase of the SPI interface | Read only | 55H |
| 3Eh | GSB Options | Options of GSB byte (standard GSB definition) | Read only | 00H |
| 3Fh | Advanced OP. Code | | | |

4.3.4 SPI modes

By reading out the SPI mode register, general information of SPI usage of the device application registers can be read.

Table 25. SPI mode

| Bit 7 | Bit 6 | Bit 5 | Bit 4 | Bit 3 | Bit 2 | Bit 1 | Bit 0 | Content |
|-------|-------|-------|-------|-------|-------|-------|-------|---------|
| BR | DL2 | DL1 | DL0 | SPI8 | 0 | S1 | S0 | A1H |

SPI burst read

Table 26. SPI burst read

| Bit 7 | Description |
|-------|-------------|
| 0 | BR disabled |
| 1 | BR enabled |

The burst read is implemented in this product so this bit is enabled.

SPI data length

The SPI data length value indicates the length of the SCK count monitor, which runs for all the accesses to the device application registers. In case a communication frame with an SCK count is not equal to the reported one, the device leads to an SPI error and the data are rejected.

The frame length is specified on 3 bits in the SPI mode register located in the ROM part.

The 24-bit SPI communication is implemented in this product so these bits are '010'.

Table 27. SPI data length

| Bit 6 | Bit 5 | Bit 4 | Description |
|-------|-------|-------|-------------|
| DL2 | DL1 | DL0 | |
| 0 | 0 | 0 | Invalid |
| 0 | 0 | 1 | 16-bit SPI |
| 0 | 1 | 0 | 24-bit SPI |
| | ... | | ... |
| 1 | 1 | 1 | 64-bit SPI |

Data consistency check (Parity/CRC)

For some devices, a Data Consistency Check is required. Therefore, either a parity-check or for very sensitive systems a CRC may be implemented.

It is defined on 2 bits, in the SPI mode register located in the ROM part. A check is then applied on the incoming frame (SDI) while a calculation elaborated on one/multiple bits is done and integrated on the outgoing frame (SDO).

Table 28. SPI data consistency check

| Bit 41 | Bit 0 | Description |
|--------|-------|-------------|
| S1 | S0 | |
| 0 | 0 | Not used |
| 0 | 1 | Parity used |
| 1 | 0 | CRC used |
| 1 | 1 | Invalid |

In case either the parity or the CRC check is implemented, it is always located at the end of the communication.

The device is equipped with the parity control check. In the Tx device, the parity bit is calculated based on the first 23 bits: even number of "1" will set the parity bit to "1", whilst the odd number of "1" will set the parity bit to "0". In the Rx device, the parity bit is calculated in the same way and compared with the received one. In the case of different parity bit, the received SPI frame is discharged.

4.4 Outputs control

Depending on the actual device mode, outputs can be controlled by the SPI register or the direct input DIx.

1. SPI register SOCR - in normal mode outputs can be turned ON/OFF, applying Bit[n] = 1/0

[n]: is the related channel, n = 0 for the channel 0, and n = 5 for channel 5

Example 1:

Turning ON channel 1 and 2 while turning OFF the others (without taking PWM or phase shifting into account)

Table 29. Write SOCR 0x13

| Bit7 | Bit 6 | Bit 5 | Bit 4 | Bit 3 | Bit 2 | Bit 1 | Bit 0 |
|----------|----------|----------|----------|----------|----------|-------|--------|
| Command | | | | | | | |
| OC1 | OC0 | Address | | | | | |
| 0 | 0 | 0 | 1 | 0 | 0 | 1 | 1 |
| D15 | Data 1 | | | | | | D8 |
| Not used | Not used | SOCR5 | SOCR4 | SOCR3 | SOCR2 | SOCR1 | SOCR0 |
| x | x | 0 | 0 | 0 | 1 | 1 | 0 |
| D7 | Data 2 | | | | | | D0 |
| Not used | Not used | Not used | Not used | Not used | Not used | WDTB | Parity |
| x | x | x | x | x | x | 1/0 | 0 |

4.4.1 Procedure to turn on the outputs in PWM operations

PWM operation

The status of the output drivers is configured via the SPI output control register (SOCR), the direct input enable bit "DIENCRx" in the OUTCFGRx register and the PWM mode control bits, PWMFCY0 and PWMFCY1, in OUTCFGRx register. The DIENCR selects if the OUTPUTX outputs are controlled also by the direct inputs IN_x or only by the SOCR. The PWMFCY bit selects the channel frequency. Refer to the following [Table 30](#) for details in normal mode.

Table 30. Output control truth table

| DIENCR (OUTCFGRx) | IN _x | SOCR _x | DUTYCR | OUTPUT _x |
|-------------------|-----------------|-------------------|--------|---------------------|
| 0 | X | 0 | X% | OFF |
| 0 | X | 1 | X% | PWM ⁽¹⁾ |
| 1 | L | 0 | X% | OFF |
| 1 | L | 1 | X% | PWM ⁽¹⁾ |
| 1 | H | X | X% | PWM ⁽¹⁾ |

1. In case of DUTYCR = 100%, PWM = DC ON .

Note: In normal mode, outputs can be driven by SPI commands or a combination of SPI commands and direct inputs IN_x.

Note: In fail-safe mode, the outputs are controlled by the direct inputs IN_x regardless of SPI commands. It is possible to apply the PWM through the DIx inputs. The PWM unit is not active in fail safe-mode, it is still possible to access the relevant registers and to configure them.

To turn on channels, information must be entered into the following registers:

- Select the PWM frequency by using the 2 bits PWMFCYx;
- Select the PHASE information by using the 5 bits CHPHAx;
- Select the switching slope by using the 2 bits SLOPECRx;
- Select the channels configuration Bulb/LED by using the bit CCR;
- Select the DUTYCYCLE information by using the 10 bits of the OUTCTRCRx registers;
- Select the channel through the dedicated register "SOCR" in the channel control register.
- Select the PWM triggering mode by using the single bit PWM_TRIG of the CTRL register

The PWMSYNC bit resets the internal 12 bits clock counter. This allows having a known time base and to synchronize different devices among each other.

The signal on the PWM_CLK is divided internally by a factor from 4096 to 512 depending on the PWMFCY register to generate the base frequency for the output.

- PWM signal is generated by properly selecting 10 of 12 bits on the clock counter. PWM engine has a virtual 10-bit granularity except when the PWM divider is set to 512, in this case only a 9-bit granularity is possible (LSB of 10-bit generated PWM is fixed to zero). Duty cycle step can be modified with the granularity related to the 9-bit register.

The duty cycle of the output signal is configured for each OUTPUTx with the OUTCTRCR register using 10 bits (MSB first).

- Programming an output duty cycle at 000h results in a 0% duty cycle that means the channel is always OFF depending on the SOCR/DIx bit setting.
- Programming an output duty cycle, at 3FFh results in a 100% duty cycle (4095/4096), that means the channel is always ON when the SOCR/DIx bit is set.
 - In normal mode the outputs are driven according to the SPI register setting and the INx pins (DIx in OR with SPI) if the related DIENCR bit is set.

Set PWMSYNC bit in the control register "CTRL" (to synchronize the internal PWM counter to the selected channels). The internal PWM counter has a 12 bits depth, it is active whatever the state of the channels if VDD > VDD_POR_ON. The setting of the PWMSYNC bit allows resetting the PWM counter.

Setting the PWM_TRIG bit in the control register "CTRL" forces the device to calculate the falling edge of the PWM window in advance compared with the end of the PWM period, while with a reset value for this bit, the rising edge of the PWM window will be calculated through a delay at the start of the PWM period.

- PWM_TRIG = 0 means channel switch on = PWM counter + phase shift counter (see examples 1 to 3)
- PWM_TRIG = 1 means channel switch off = PWM counter (max) - phase shift counter - duty cycle (see example 4)

The phase shift of the output signal is configured for each OUTPUTx by internally concatenating the CHPHAx 5 bits with '00000' in order to get 10 bits. Granularity of the phase shift is 5 bits. CHPHA = 00000b means a phase shift of 0 (internal 10bit phase shift is 0x000=0000000000b), while CHPHA = 11111b results in a maximum phase shift of 31/32=(internal 10bit phase shift is 0x3E0=0000000000b)

The phase shift is relative to the base frequency of the selected channel. Thus, the exact point in time when the channel switches on also depends on the operating mode of the selected channel.

Table 31. Phase shift configuration

| Phase shift (%) | 5 bits Register (H) | 10 bits Register (H) | Phase shift (ms) | Phase shift (ms) | Phase shift (ms) |
|-----------------|---------------------|----------------------|---------------------------------|---------------------------------|--------------------------------|
| | | | PWM = 400 kHz Divider = 2048 | PWM = 400 kHz Divider = 1024 | PWM = 400 kHz Divider = 512 |
| 9.4 | 03 | 60 | 0.481 | 0.24 | 0.12 |
| 28.1 | 09 | 120 | 1.439 | 0.719 | 0.360 |
| 46.9 | 0F | 1E0 | 2.40 | 1.2 | 0.6 |
| 75 | 17 | 2E0 | 3.84 | 1.92 | 0.96 |
| 90 | 1C | 380 | 4.608 | 2.304 | 1.152 |

A change in phase/duty will be taken in account after the next zero-crossing of the PWM counter.

Note: *If the frequency on PWM_CLK is too low ($f < PWM_CLK$), the device falls back to an internally generated PWM frequency of approximately 400 kHz. In this case, the PWMCLOCKLOW bit in OUTSRx is set.*

Example 1:

Below, an example with a 65% duty cycle, PWM divider = 2048 and a 25% phase is given with a PWM sampling mode on the rising edge (PWM_TRIG=0):

- 65% duty cycle results in a DUTYCRx register content equal to 665 = Ch ($65\% \times 1023 = 665 - 299$).
- 25% phase results in a CHPA register content equal to 8 ($25\% \times 31 = 8$), equivalent to a content of 256 = 100h for a 10 bit register.
- With an input frequency at PWM_CLK pin of 400 kHz, the output frequency is 195 Hz.

Figure 12. Resulting waveform 1

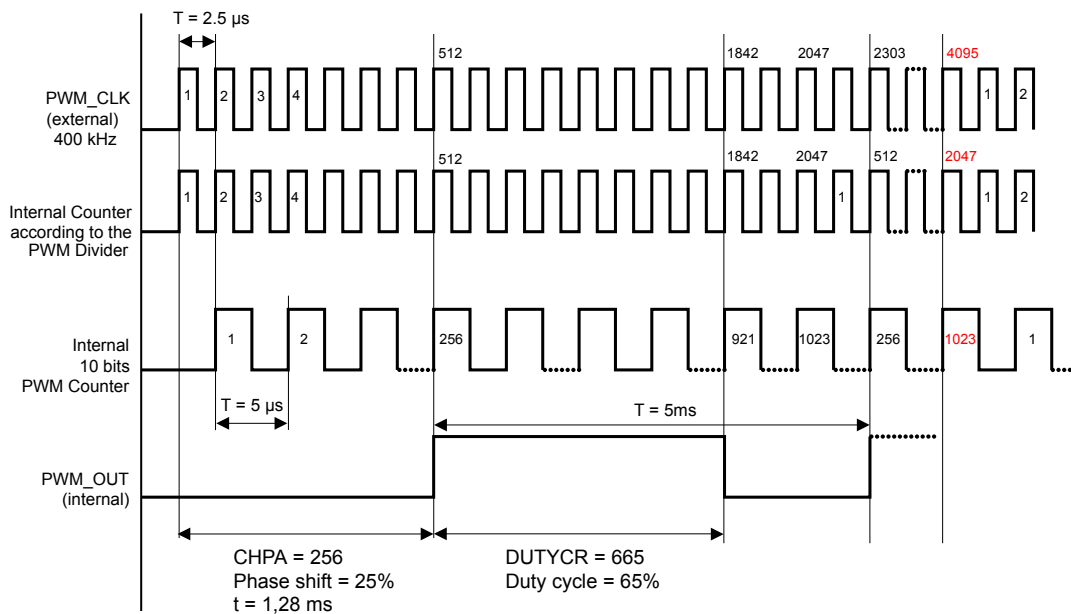

GADG0604171543PS

Example 2:

Below, an example with a 65% duty cycle, PWM divider = 1024 and a 45% phase is given with a PWM sampling mode on the rising edge (PWM_TRIG=0):

- 65% duty cycle results in a DUTYCRx register content equal to 665 = Ch ($65\% \times 1023 = 665 - 299$).
- 45% phase results in a CHPA register content equal to 14 ($45\% \times 31 = 14$), equivalent to a content of 448 = 1C0h for a 10 bit register.
- With an input frequency at PWM_CLK pin of 400 kHz, the output frequency is 390 Hz.

Figure 13. Resulting waveform 2

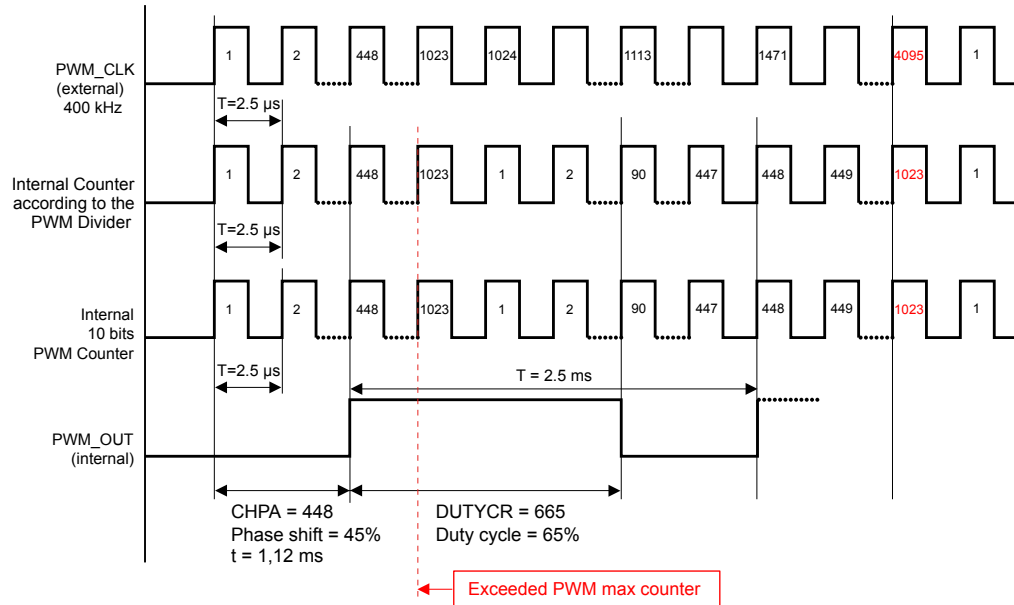

GADG0604171550PS

Example 3:

Below, an example with a 65% duty cycle, PWM divider = 512 and a 45% phase is given with a PWM sampling mode on the rising edge (PWM_TRIG = 0):

- 65% duty cycle results in a DUTYCRx register content equal to 665 = Ch (65% x 1023 = 665 - 299).
- 45% phase results in a CHPA register content equal to 14 (45% x 31 = 14), equivalent to a content of 448 = 1C0h for a 10 bit register.
- With an input frequency at PWM_CLK pin of 400 kHz, the output frequency is 781 Hz.

Figure 14. Resulting waveform 3

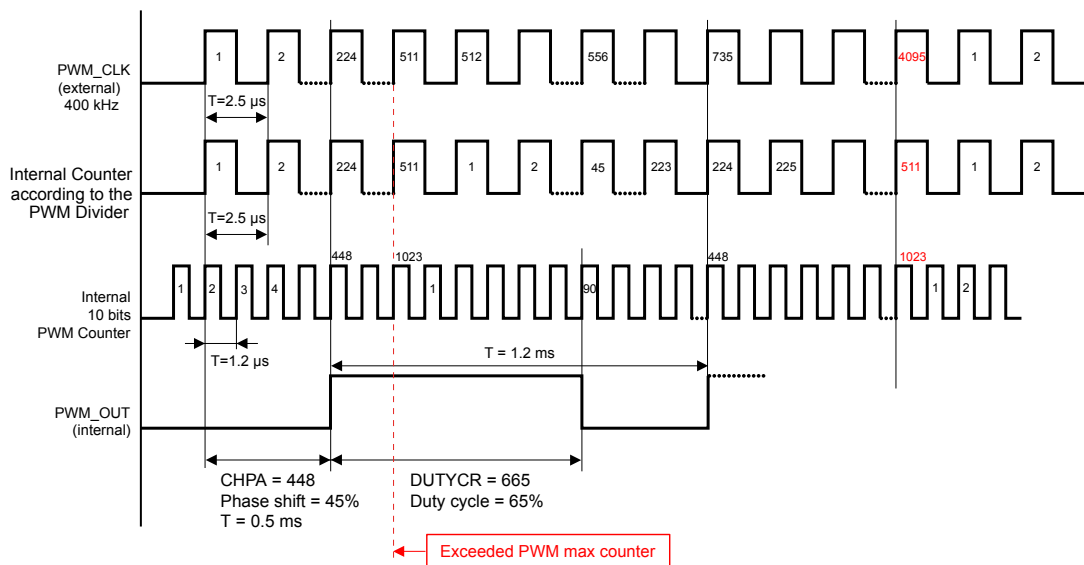

GADG0604171550PS

Example 4:

Below, an example with a 65% duty cycle, PWM divider = 512 and a 45% phase is given with a PWM sampling mode on the falling edge (PWM_TRIG=1):

- 65% duty cycle results in a DUTYCRx register content equal to 665 ($65\% \times 1023 = 665$) equivalent to a content of 299h.
- 45% phase results in a CHPA register content equal to 14 ($45\% \times 31 = 14$), equivalent to a content of 448 = 1C0h for a 10-bit register.
- With an input frequency at PWM_CLK pin of 400 kHz, the output frequency is $400/1024 = 390$ Hz
- Due to PWM sampling mode on the falling edge, the PWM window has a start at 3A6h (not (299h +1C0h)) and a stop at 23Fh (not 1C0h).

Figure 15. Resulting waveform 4

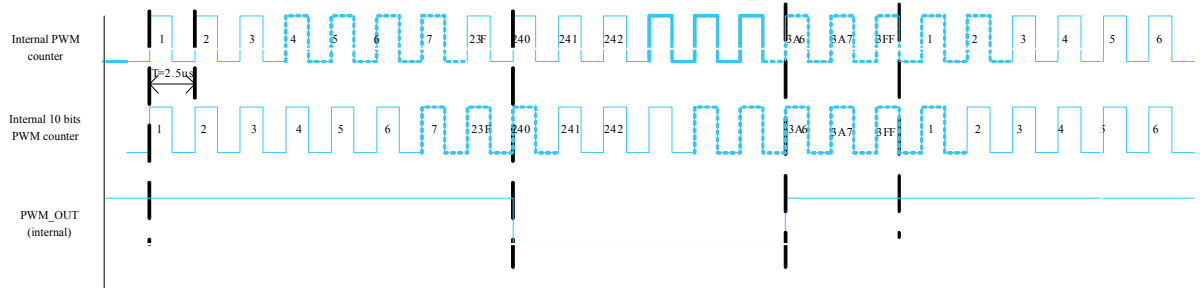

4.4.2 OTP programming

The direct input assignment to output through the OTP programming is achievable by setting the two dedicated bits per channel in the OTP memory map according to the following table:

Table 32. OTP memory map

| OTP memory map | bit 1, bit 0 | bit 1, bit 0 | bit 1, bit 0 | bit 1, bit 0 |
|----------------|--------------|--------------|--------------|--------------|
| | 00 | 01 | 10 | 11 |
| CH5 | DI0 | DI0 | DI1 | OFF |
| CH4 | DI1 | DI0 | DI1 | OFF |
| CH3 | DI1 | DI0 | DI1 | OFF |
| CH2 | DI1 | DI0 | DI1 | OFF |
| CH1 | DI1 | DI0 | DI1 | OFF |
| CH0 | DI0 | DI0 | DI1 | OFF |

Note: "00" represents the default configuration.

The device is provided with the default configuration corresponding to the first column in the previous table (00). A customized OTP configuration, for each channel, is possible by changing the two dedicated bits.

Table 33. OTP programming

| Dlx assignment | | | | | | | | | | | |
|----------------|-------|-------|-------|-------|-------|-------|-------|-------|-------|-------|-------|
| Ch5 | | Ch4 | | Ch3 | | Ch2 | | Ch1 | | Ch0 | |
| bit 1 | bit 0 | bit 1 | bit 0 | bit 1 | bit 0 | bit 1 | bit 0 | bit 1 | bit 0 | bit 1 | bit 0 |
| n | n | n | n | n | n | n | n | n | n | n | n |

Each output status register (OUTSRx) per channel contains the bits DIOTP1, DIOTP0, which reports the assigned direct input signal to the channel.

The OTP programming mode can be entered by applying a dedicated procedure in order to ensure a very high safety level for the stored configurations and to prevent from unwanted changing.

Further information about the OTP programming mode is provided in the dedicated user manual.

4.4.3 Procedure to turn on the outputs with the direct input Dlx

By applying a logic level high/low to pin, the associated OTP selected outputs are turned on or off in fail-safe, standby, and reset modes. In normal mode, the Dlx effect is ORed with SPI configuration when DIENCR bit is set. Then the following truth table specifies the output state:

Table 34. Truth table

| DIECRx | SOCRx | Related Dlx logic status | OUTPUTx state |
|--------|-------|--------------------------|---------------|
| 1 | 1 | X | ON |
| 1 | 0 | L | OFF |
| 1 | 0 | H | ON |
| 0 | 1 | X | ON |
| 0 | 0 | X | OFF |

The output channels can be configured to operate in BULB or LED mode using the Channel control Register (CCR). If the relevant bit in CCR is 0, the output is configured in BULB mode, if it is set to 1, the output is configured in LED mode (default value is 0).

Figure 16. 6-channel direct input block diagram

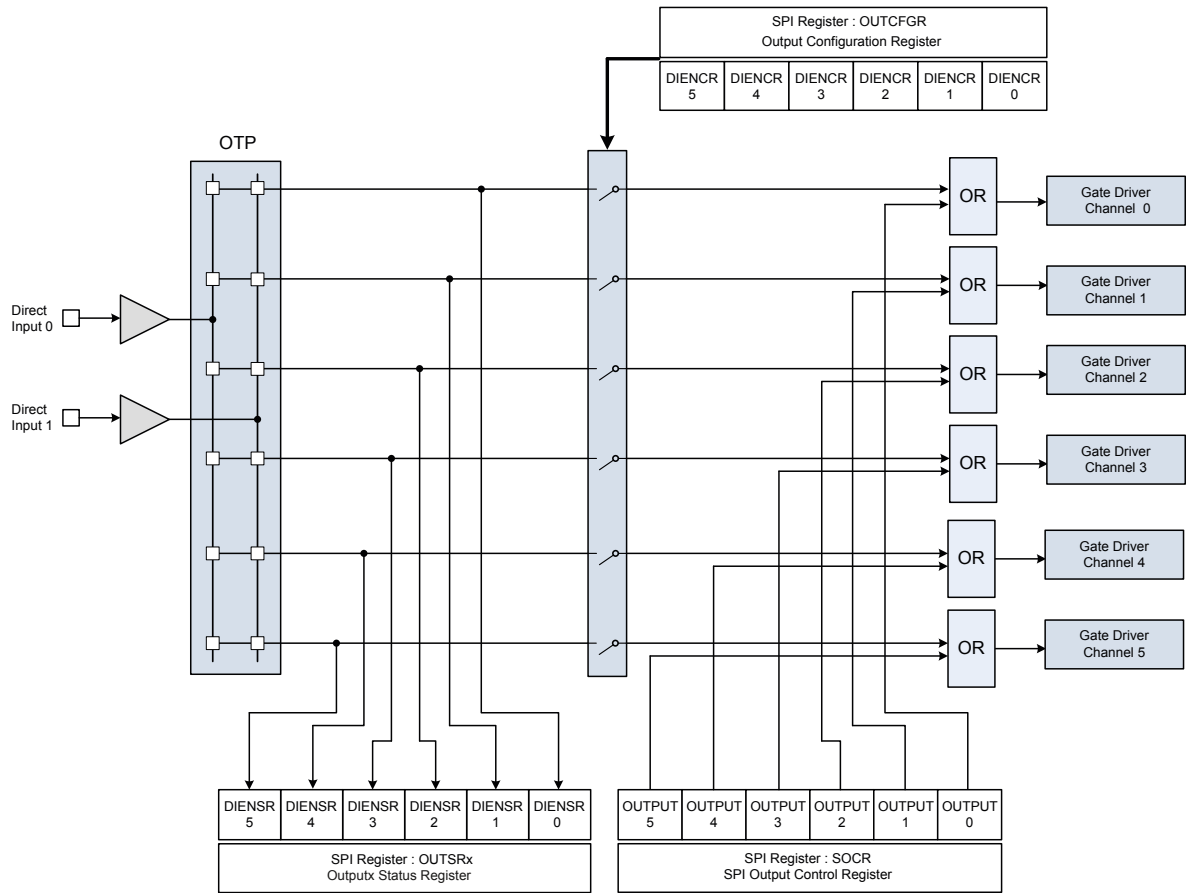

GADG2710171259PS

4.5 Output switching slopes control

Output switching slopes are set by the two bits SLOPECR1, 2 in the OUTCFGCRx register (address from 0x08h to 0x0Dh depending of the channel). The switching slopes are shown in the following table:

Table 35. Switching slopes

| SLOPECRx | Channel 0,5 (V/μs) | Channel 1,2,3,4 (V/μs) |
|----------|--------------------|------------------------|
| 00 | Standard | Standard |
| 01 | Fast | Fast |
| 10 | Faster | Faster |
| 11 | Fastest | Fastest |

4.6 Control registers

OUTCTRCRx

Outputs control register

| | | | | | | | | | | | | | | | |
|----------|----------|---------|---------|---------|---------|---------|---------|---------|---------|---------|---------|----------|---------|------|--------|
| 15 | 14 | 13 | 12 | 11 | 10 | 9 | 8 | 7 | 6 | 5 | 4 | 3 | 2 | 1 | 0 |
| RESERVED | RESERVED | DUTYCR9 | DUTYCR8 | DUTYCR7 | DUTYCR6 | DUTYCR5 | DUTYCR4 | DUTYCR3 | DUTYCR2 | DUTYCR1 | DUTYCR0 | RESERVED | OLOFFCR | WDTB | PARITY |
| R | R | RW | RW | RW | RW | RW | RW | RW | RW | RW | RW | R | RW | RW | R |

Address: 0x00h to 0x05h
Type: RW
Reset: 0
Description: Outputs control register

| | |
|---------|---|
| [15:14] | RESERVED |
| [13:4] | DUTY_CR[9:0]: set the duty cycle value. Bit 9 (MSB) - Bit 0 (LSB) |
| [3] | RESERVED |
| [2] | OLOFFCR: enables an internal pull-up current generator to distinguish between the two faults: open-load OFF-state vs the output shorted to V_{CC} fault. 1: pull-up current generator enabled 0: pull-up current generator disabled |
| [1] | WDTB: watchdog toggle bit |
| [0] | PARITY: parity bit |

OUTCFGRx
Outputs configuration register

| | | | | | | | | | | | | | | | |
|----------|----------|----------|--------|--------|--------|--------|--------|-------|-------|---------|---------|-----|--------|---------|--------|
| 15 | 14 | 13 | 12 | 11 | 10 | 9 | 8 | 7 | 6 | 5 | 4 | 3 | 2 | 1 | 0 |
| SLOPECR1 | SLOPECR0 | RESERVED | CHPHA4 | CHPHA3 | CHPHA2 | CHPHA1 | CHPHA0 | SPCR1 | SPCR0 | PWMFCY1 | PWMFCY0 | CCR | DIENCR | VDSMASK | PARITY |
| RW | RW | RW | RW | RW | RW | RW | RW | RW | RW | RW | RW | RW | RW | RW | R |

Address: 0x08h to 0x0Dh

Type: RW

Reset: 0

Description: The “Output configuration register” allows setting the following important parameters for each channel:

- Switching related parameters
 - Switching slopes;
 - Phase of each channel;
 - PWM ratio;
- Channel configuration
 - Bulb/LED mode;
 - Control through SPI/DIx pins;
 - Masking the VDS control at turn-off;
- Diagnostic configuration
 - Set the current sampling point for the digital conversion;

[15:14] SLOPECR[1:0]: Switching slope control bit 1 (MSB) and 0 (LSB)

[13] RESERVED

CHPHA[4:0]:

Set the Channel phase value[4:0]

00000: Resulting phase = 0/32

[12:8] 00001: Resulting phase = 1/32

....

11110: Resulting phase = 30/32

11111: Resulting phase = 31/32

SPCR[1:0]:

Current sampling Point[1:0]

SPCR1:0 SPCR0:0 stop mode: authorizes digital conversion to be launched just before the end of on phase of the selected channel.

[7:6] SPCR1:0 SPCR0:1 START mode: authorizes digital conversion to be launched at each beginning of on phase of the selected channel.

SPCR1:1 SPCR0:0 CONTINUOUS mode: authorizes digital conversion during all on phase of the selected channel.

SPCR1:1 SPCR0:1 FILTERED mode: authorizes digital conversion like CONTINUOUS mode with the use of low pass filter to filter data coming from the conversion. It is useful at low level output current.

PWMFCY[1:0]:

PWM frequency selection[1:0]

[5:4] Each output has a specific ratio for its PWM functionality. This mode is defined through two dedicated bits PWMFCY1 and PWMFCY0 of OUTCFGRx registers.

PWMFCY1:0 PWMFCY0:0 = PWM freq ratio: 1024

PWMFCY1:0 PWMFCY0:1 = PWM freq ratio: 2048

PWMFCY1:1 PWMFCY0:0 = PWM freq ratio: 4096

PWMFCY1:1 PWMFCY0:1 = PWM freq ratio: 512

When a combination is selected, the output frequency of the selected channel will be the PWM clock input frequency divided by the defined ratio.

CCR: set the channel configuration (Bulb-LED)

[3] 0: Bulb mode

1: LED mode

DIENCR: Direct input signal enable in normal mode (according to OTP allocation)

[2] Each output has an OTP programmed direct input assignment for limp-home operation. Any output can be programmed to be always OFF in the limp-home, or according to DI0 pin state or according to DI1 pin state. This programmed assignment can be read from DIOTP bits of OUTSRx status register. When DIENCR bit is set, DIx pin state assigned to the output is ORed with the SOCR/PHASE/DUTYCYCLE combination to control output state. In fail-safe, standby and reset modes applying log.1/0 to pin turns ON/OFF the associated OTP selected outputs.

[1] VDSDMASK: VDS detection at turn-off masking bit

[0] PARITY: parity bit

CHLOFFTCR0
Channel Latch OFF Timer Control register

| | | | | | | | | | | | | | | | |
|-------------|-------------|-------------|-------------|-------------|-------------|-------------|-------------|-------------|-------------|-------------|-------------|----------|----------|----------|--------|
| 15 | 14 | 13 | 12 | 11 | 10 | 9 | 8 | 7 | 6 | 5 | 4 | 3 | 2 | 1 | 0 |
| CHLOFFTCR23 | CHLOFFTCR22 | CHLOFFTCR21 | CHLOFFTCR20 | CHLOFFTCR13 | CHLOFFTCR12 | CHLOFFTCR11 | CHLOFFTCR10 | CHLOFFTCR03 | CHLOFFTCR02 | CHLOFFTCR01 | CHLOFFTCR00 | RESERVED | RESERVED | RESERVED | PARITY |
| RW | RW | RW | RW | RW | RW | RW | RW | RW | RW | RW | RW | R | R | R | R |

Address: 0x10h

Type: RW

Reset: 0

Description: The output behavior in case of power limitation or thermal shut-down is programmable, as latch-off or Time limited auto-restart (tblanking). The default mode is the latch-off one which corresponds to have 0x0h in the register. In Time limited autorestart, when the channel is turned ON, after a transition from 0 to 1 of the corresponding SOCR bit or activation through associated DIx input when DIENCR bit is set, power limitation and thermal shutdown latches are inhibited for a programmed tblanking time.

See Programmable blanking window (PBW) for more details.

Two Registers are used for setting the $t_{blanking}$ values for each channel:

- CHLOFFTCR0 for channels 2,1,0;
- CHLOFFTCR1 for channel 5,4,3.

| | |
|---------|---|
| [15:12] | CHLOFFTCR[23:20]: It configures the output behavior in case of power limitation for the corresponding channel 2. |
| [11:8] | CHLOFFTCR[13:10]: It configures the output behavior in case of power limitation for the corresponding channel 1. |
| [7:4] | CHLOFFTCR[03:00]: It configures the output behavior in case of power limitation for the corresponding channel 0. |
| [3:1] | RESERVED |
| [0] | PARITY: parity bit |

CHLOFFTCR1
Channel Latch OFF Timer Control register

| | | | | | | | | | | | | | | | |
|-------------|-------------|-------------|-------------|-------------|-------------|-------------|-------------|-------------|-------------|-------------|-------------|----------|----------|----------|--------|
| 15 | 14 | 13 | 12 | 11 | 10 | 9 | 8 | 7 | 6 | 5 | 4 | 3 | 2 | 1 | 0 |
| CHLOFFTCR53 | CHLOFFTCR52 | CHLOFFTCR51 | CHLOFFTCR50 | CHLOFFTCR43 | CHLOFFTCR42 | CHLOFFTCR41 | CHLOFFTCR40 | CHLOFFTCR33 | CHLOFFTCR32 | CHLOFFTCR31 | CHLOFFTCR30 | RESERVED | RESERVED | RESERVED | PARITY |
| RW | RW | RW | RW | RW | RW | RW | RW | RW | RW | RW | RW | R | R | R | R |

Address: 0x11h

Type: RW

Reset: 0

Description: The output behavior in case of power limitation or thermal shut-down is programmable, as latch-off or Time limited auto-restart (tblanking). The default mode is the latch-off one which corresponds to have 0x0h in the register. In Time limited autorestart, when the channel is turned ON, after a transition from 0 to 1 of the corresponding SOCR bit or activation through associated DIx input when DIENCR bit is set, power limitation and thermal shutdown latches are inhibited for a programmed tblanking time.

See Programmable blanking window (PBW) for more details.

Two Registers are used for setting the $t_{blanking}$ values for each channel:

- CHLOFFTCR0 for channels 2,1,0;
- CHLOFFTCR1 for channel 5,4,3.

| | |
|---------|---|
| [15:12] | CHLOFFTCR[53:50]: It configures the output behavior in case of power limitation for the corresponding channel 5. |
| [11:8] | CHLOFFTCR[43:40]: It configures the output behavior in case of power limitation for the corresponding channel 4. |
| [7:4] | CHLOFFTCR[33:30]: It configures the output behavior in case of power limitation for the corresponding channel 3. |
| [3:1] | RESERVED |
| [0] | PARITY: parity bit |

The blanking window duration in case of power limitation or thermal shutdown events can be set according to the following table:

Table 36. Programmable $t_{blanking}$ values

| CHLOFFTCRx3 | CHLOFFTCRx2 | CHLOFFTCRx1 | CHLOFFTCRx0 | | |
|-------------|-------------|-------------|-------------|-----|-------------------------|
| 0 | 0 | 0 | 0 | 0x0 | latch OFF cfg (default) |
| 0 | 0 | 0 | 1 | 0x1 | 16ms |
| 0 | 0 | 1 | 0 | 0x2 | 32ms |
| . | . | . | . | | |
| 1 | 1 | 1 | 0 | 0xE | 224ms |
| 1 | 1 | 1 | 1 | 0xF | 240ms |

SOCR
Channel control register

| | | | | | | | | | | | | | | | |
|----------|----------|-------|-------|-------|-------|-------|-------|----------|----------|----------|----------|----------|----------|------|--------|
| 15 | 14 | 13 | 12 | 11 | 10 | 9 | 8 | 7 | 6 | 5 | 4 | 3 | 2 | 1 | 0 |
| RESERVED | RESERVED | SOCR5 | SOCR4 | SOCR3 | SOCR2 | SOCR1 | SOCR0 | RESERVED | RESERVED | RESERVED | RESERVED | RESERVED | RESERVED | WDTB | PARITY |
| R | R | RW | RW | RW | RW | RW | RW | R | R | R | R | R | R | RW | R |

Address: 0x13h

Type: RW

Reset: 0

Description: The SOCR register is used to turn ON/OFF the related channel. The WDTB bit that must be toggled within t_{WDBT} (watchdog timeout) to avoid entering in fail-safe mode. This bit is already present in the output control register and it is duplicated in the SOCR register to simplify the SPI usage.

| | |
|---------|---|
| [15:14] | RESERVED |
| [13] | SOCR5 bit controls output state of channel 5 1 - output enabled 0 - output disabled |
| [12] | SOCR4 bit controls output state of channel 4 1 - output enabled 0 - output disabled |
| [11] | SOCR3 bit controls output state of channel 3 1 - output enabled 0 - output disabled |
| [10] | SOCR2 bit controls output state of channel 2 1 - output enabled 0 - output disabled |
| [9] | SOCR1 bit controls output state of channel 1 1 - output enabled 0 - output disabled |
| [8] | SOCR0 bit controls output state of channel 0 1 - output enabled 0 - output disabled |
| [7:2] | RESERVED |
| [1] | Watchdog toggle bit |
| [0] | PARITY: parity bit |

CTRL
Control register

| | | | | | | | | | | | | | | | |
|--------|--------|--------|--------|----|----------|----------|----------|----------|---------|---------|---------|---------|---------|---------|--------|
| 15 | 14 | 13 | 12 | 11 | 10 | 9 | 8 | 7 | 6 | 5 | 4 | 3 | 2 | 1 | 0 |
| GOSTBY | UNLOCK | CTDTH1 | CTDTH0 | EN | PWM_TRIG | RESERVED | RESERVED | RESERVED | LOCKEN4 | LOCKEN3 | LOCKEN2 | LOCKEN1 | LOCKEN0 | PWMSYNC | PARITY |
| RW | RW | RW | RW | RW | RW | R | R | R | RW | RW | RW | RW | RW | W | R |

Address: 0x14h
Type: RW
Reset: 0
Description: Control register

- GOSTBY: Go to standby.
- [15] It is necessary to do 2 write accesses to enter standby:
1. Write UNLOCK = 1
 2. Write GOSTBY = 1 and EN = 0
-
- UNLOCK: unlock bit
- [14] UNLOCK bit allows protected SPI transactions. It means that the next SPI communication will automatically clear this bit and prevent any change of protected data (like slope control or BULB/LED mode for example). As a consequence, modifying a protected data requires to set UNLOCK bit in a first communication and write the protected data during the next communication.
-
- CTDTH[1:0]: Case thermal detection threshold. These bits allow to configure the case thermal detection of the device. Three temperature thresholds are available by programming these two bits.
- [13:12]
1. CTDTH1:0 CTDTH0:0 = detection temperature:120 °C
 2. CTDTH1:0 CTDTH0:1 = detection temperature:130 °C
 3. CTDTH1:1 CTDTH0:X = detection temperature:140 °C
-
- EN: enter normal mode
- 1: normal mode
- [11] 0: fail-safe mode
- It is necessary to do 2 write accesses to enter normal mode:
1. Write UNLOCK = 1
 2. Write EN = 1
-
- PWM_TRIG: PWM triggering mode
- [10] 0: PWM trigger according to the rising edge of PWM period and phase shift configuration
- 1: PWM trigger according to the falling edge of PWM period and phase shift configuration
-
- [9:7] RESERVED
-
- LOCKEN[4:0]: Protected transaction mode
- LOCKEN4: Lock enable for slope control SLOPECRx
- LOCKEN3: Lock enable for BULB/LED mode CCRx
- LOCKEN2: Lock enable for phase shift CHPHAx
- [6:2] LOCKEN1: Lock enable for configurable blanking time CHLOFFTCRx
- LOCKEN0: Lock enable for PWM clock synchronization
- When the bit is set (LOCKENx = 1), it is used to have a protected transaction:
- setting UNLOCK bit
 - modify the relevant configuration register
- When LOCKENx=0 (reset value), the related configuration registers are altered with a simple write command.

- [1] PWMSYNC: PWM clock synchronization.
PWMSYNC =1 clears PWM internal counter. It automatically resets at next SPI communication
-
- [0] PARITY: parity bit
-

OUTSRx
Output status channels 0 to 5 register

| | | | | | | | | | | | | | | | |
|--------|--------|--------|---------|---------|----------|---------|-----------|-----|------|-------------|-------|----------|----------|----------|--------|
| 15 | 14 | 13 | 12 | 11 | 10 | 9 | 8 | 7 | 6 | 5 | 4 | 3 | 2 | 1 | 0 |
| DIENSR | DIOTP1 | DIOTP0 | CHFBSRx | VDSFSRx | STKFLTRx | OLPUSRx | CHLOFFSRx | RST | SPIE | PWMCLOCKLOW | VCCUV | RESERVED | RESERVED | RESERVED | PARITY |
| R | R | R | RC | RC | RC | R | R | RC | RC | RC | R | R | R | R | R |

Address: 0x20h to 0x25h

Type: RC

Reset: 0

Description: The output status register reports the status of the selected channel based on the configuration register and in case of fault condition.

| | |
|-------|--|
| [15] | DIENSR: direct input status, image of associated DI logic level according to OTP allocation. |
| [14] | DIOTP1: associated DIx input description bit 1 |
| [13] | DIOTP0: associated DIx input description bit 0 |
| [12] | CHFBSRx: channel feedback status. Channel feedback status. Combination of power limitation, OT, OVERLOAD detection (VDS at turn-off). The CHFBSRx provides a logical "OR" combination of VDS (overload), PL (power limitation), OT (overtemperature) failure flags related to OUTPUTx, and it is cleared by a read and clear command. |
| [11] | VDSFSRx: VDS feedback status. This bit is '1' if VDS is high at turn-off, indicative of a potential overload condition |
| [10] | STKFLTRx: output stuck to V_{CC} /open-load off state status. |
| [9] | OLPUSRx: output pull-up generator status. |
| [8] | CHLOFFSRx: channel latch-off status. This bit is set when overload blanking time has elapsed and the channel is latched off. |
| [7] | RST: chip reset |
| [6] | SPIE: SPI error |
| [5] | PWMCLOCKLOW: PWM clock frequency too low. |
| [4] | VCCUV: V_{CC} undervoltage |
| [3:1] | RESERVED |
| [0] | PARITY: parity bit |

ADCxSR
Digital Current Sense register

| | | | | | | | | | | | | | | | |
|----------|----------|---------------|---------|---------|---------|---------|---------|---------|---------|---------|---------------|----------|-------------------|--------|--------|
| 15 | 14 | 13 | 12 | 11 | 10 | 9 | 8 | 7 | 6 | 5 | 4 | 3 | 2 | 1 | 0 |
| RESERVED | RESERVED | ADCxSR9 (MSB) | ADCxSR8 | ADCxSR7 | ADCxSR6 | ADCxSR5 | ADCxSR4 | ADCxSR3 | ADCxSR2 | ADCxSR1 | ADCxSR0 (LSB) | RESERVED | SOCR _x | UPDTSR | PARITY |
| R | R | R | R | R | R | R | R | R | R | R | R | R | R | R | R |

Address: 0x28h to 0x2Dh

Type: R

Reset: 0

Description: The register contains the digital value of the current flowing on the selected channel. It reports the result of the digital current conversion. It is updated according to the modes set by the two bits (SPCR1 and SPCR0) of the [OUTCFGR_x](#).

| | |
|---------|---|
| [15:14] | RESERVED |
| | ADCxSR[9:0]: The 10 bit register contains the digital value of OUTPUT _x current. |
| [13:4] | ADCxSR9 (MSB) ADCxSR0 (LSB) |
| [3] | RESERVED |
| | SOCR _x : SOCR Bit controls output state of channel x. |
| [2] | 1 - output enabled 0 - output disabled |
| [1] | UPDTSR: updated status bit. This bit is set when a value is updated and cleared when register is read. |
| [0] | PARITY: parity bit |

ADC9SR
Digital Case Thermal Sensor Voltage register

| | | | | | | | | | | | | | | | |
|----------|----------|---------------|---------|---------|---------|---------|---------|---------|---------|---------|---------------|----------|----------|--------|--------|
| 15 | 14 | 13 | 12 | 11 | 10 | 9 | 8 | 7 | 6 | 5 | 4 | 3 | 2 | 1 | 0 |
| RESERVED | RESERVED | ADC9SR9 (MSB) | ADC9SR8 | ADC9SR7 | ADC9SR6 | ADC9SR5 | ADC9SR4 | ADC9SR3 | ADC9SR2 | ADC9SR1 | ADC9SR0 (LSB) | RESERVED | RESERVED | UPDTSR | PARITY |
| R | R | R | R | R | R | R | R | R | R | R | R | R | R | R | R |

Address: 0x31h

Type: R

Reset: 0

Description: The register contains the result of the digital conversion of the case temperature.

| | |
|---------|--|
| [15:14] | RESERVED |
| | ADC9SR[9:0]: The 10 bit register contains the digital value of case temperature sensor voltage. |
| [13:4] | ADC9SR9 (MSB) ADC9SR0 (LSB) $T_{CASE} (typ.) = 401.8 \text{ }^{\circ}\text{C} - 1.009 * \text{ADC9SR}[13:4]$ |
| [3:2] | RESERVED |
| [1] | UPDTSR: updated status bit. This bit is set when a value is updated and cleared when register is read. |
| [0] | PARITY: parity bit |

OTP memory map (Reserved)

OTP is automatically read into registers at Reset.
 OTP memory map contains Direct Inputs assignment to outputs,
 Direct Inputs assignment data (2 bits per channel):

Table 37. OTP memory map (reserved)

| Dlx assignment bit 1 | Dlx assignment bit 0 | CH5 | CH4 | CH3 | CH2 | CH1 | CH0 |
|----------------------|----------------------|-----|-----|-----|-----|-----|-----|
| 0 | 0 | DI0 | DI1 | DI1 | DI1 | DI0 | DI0 |
| 0 | 1 | DI0 | DI0 | DI0 | DI0 | DI0 | DI0 |
| 1 | 0 | DI1 | DI1 | DI1 | DI1 | DI1 | DI1 |
| 1 | 1 | OFF | OFF | OFF | OFF | OFF | OFF |

5 Diagnostics

Device is capable to provide digital diagnostics information through SPI interface.

5.1 Digital current sense diagnostics

5.1.1 ADC characteristics

Here are the typical “Differential non linearity” and “Integral non Linearity” typical curves for the 10-bit ADC converter.

Figure 17. ADC characteristics and error definition

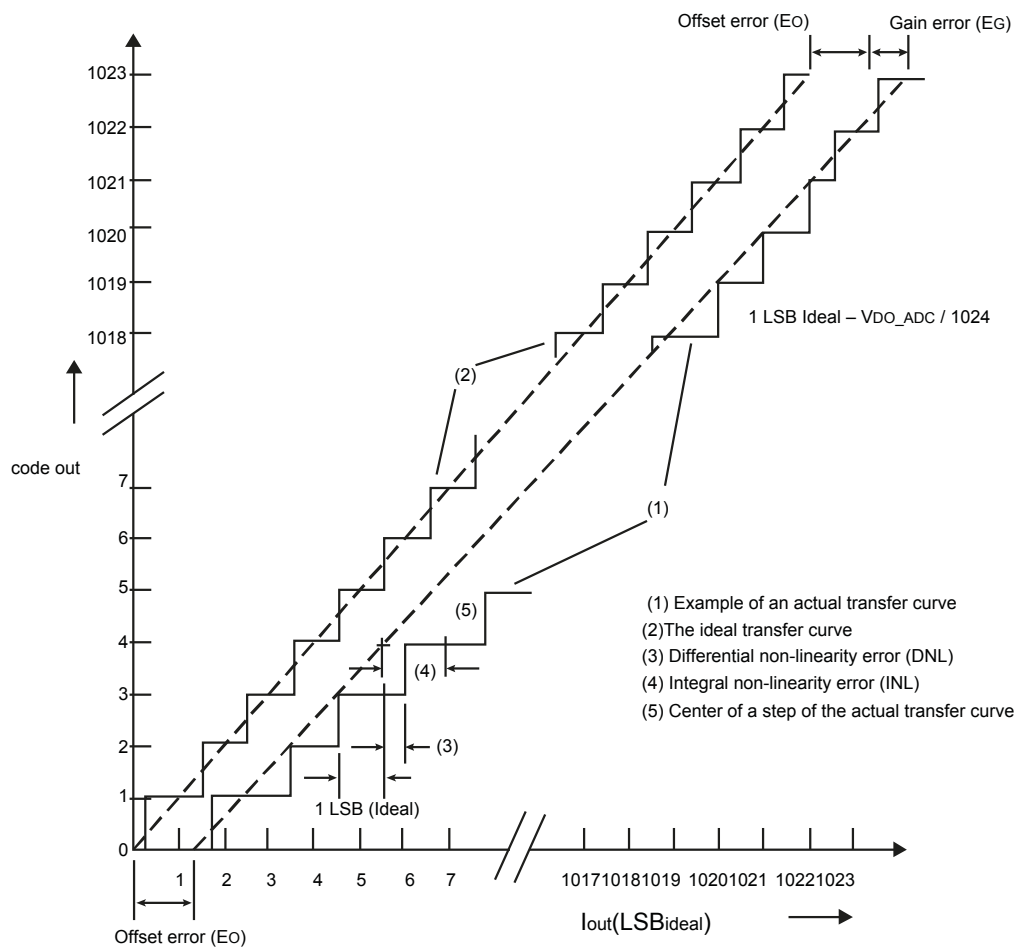

GADG311020171221MT

5.1.2 ADC operating principle

The device provides a 10-bit successive approximation register (SAR) analog-to-digital converter. It is used to provide digital information about the current sense feedback proportional to the output current and the temperature read by the internal sensor. An integrated LP (progressive average) filter can be used to filter data coming from the ADC conversion reducing the effect of random noise coming from the analog current sense amplifier.

Note: The internal ADC is able to work in both normal and fail-safe conditions.

The integrated ADC control logic is designed to lead to a good 10-bit approximation of current sense/temperature feedback.

After each conversion, an updated bit “UPDTSR” is set to advise about new conversion data. This bit is reset after the read process of dedicated RAM register.

Data is maintained in the register until the next conversion results is available. ADC register is refreshed at the end of each conversion and maintained during conversion of the current sample. Data is converted on the 10-bit register, the formula is equal to:

$$I_{out_conv} = \text{data (10bit)}/K;$$

An analog multiplexer has been implemented to connect the different channels to the amplifier and ADC block. Due to the current sense amplifier's settling time, when switching from the current sense mode of one channel to the current sense mode of another channel, a priority management is implemented to control the time when data conversion can be done in a safe/stable way and to arbitrate concurrent ADC sampling requests (see next figures).

Figure 18. Conversion window generation

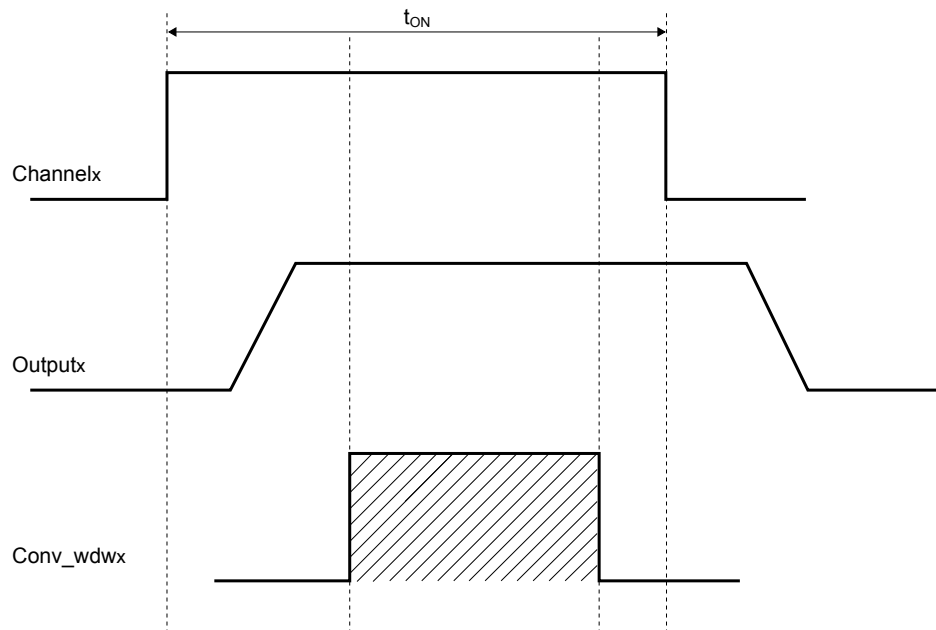

GADG311020171222MT

A minimum conversion time ($t_{ON_CS_min}$) is defined to allow the signal stabilization at the input of the ADC converter and considering the sampling time. The user should manage the phase shift in a way that two channels at maximum can be sampled in the same time window.

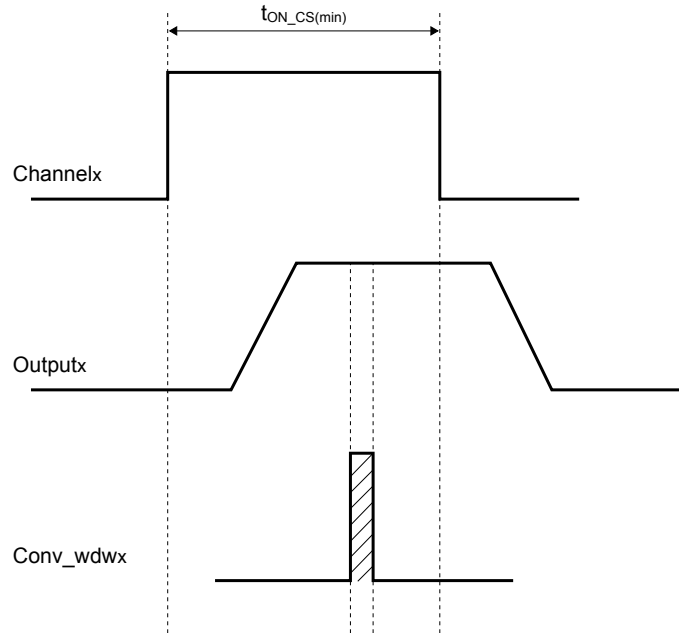
Figure 19. Minimum ON time for digital current sense availability

GADG311020171223MT

The sequence of channels to be converted is managed through an internal stack:

- Stack size is equal to number of channels plus frame temperature sensor
- A conversion of the selected channel is done based on the information stored at the end of stack (see Figure 20. Channel's sequence internal stack)
- After reset of the device or when no channels are active, the conversion of frame temperature sensor is done continuously
- When the conversion of a channel_x has to start, the channel_x is moved to the end of stack while other remaining channels are moved up

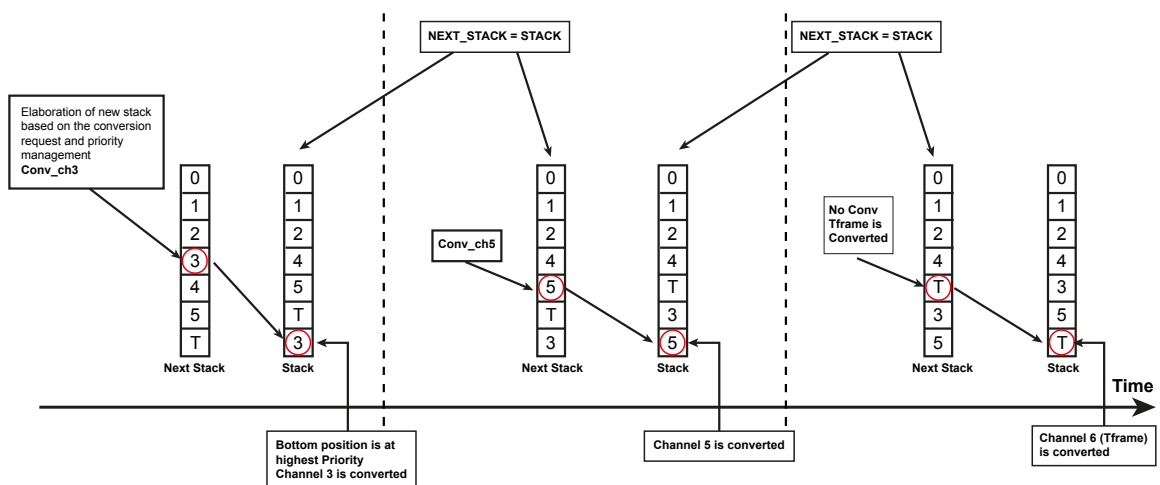
Figure 20. Channel's sequence internal stack

GADG311020171225MT

Note: The figure above shows an example of how the priority is managed through a stack in a six channels device.

5.1.3 Registers

The results of the digital conversion are stored in the “Digital Current Sense Registers”. The two following registers are used for the digital conversion of the output current and the case sense temperature respectively:

- **ADCxSR** (address from 28h to 2Dh) - for digital Outputx current (one register x channel)
- **ADC9SR** (address 31h) - Digital case temperature sensor voltage sense register

Table 38. Registers

| Register name | Bit 15,14 | Bit 13..4 | Bit 3 | Bit 2 | Bit 1 | Bit 0 |
|----------------------|-----------|--|----------|--|---|--------|
| ADCxSR 28h to 2Dh | Not Used | Digital Value of OUTx current | Not Used | SOCRx Possibility to control the Outx state (Read only) | UPDTSR Updated status bit. It is set when value is updated and cleared when register is read | Parity |
| ADC9SR 31h | Not Used | Digital Value of case temperature sensor voltage | Not Used | | UPDTSR Updated status bit. It is set when value is updated and cleared when register is read | Parity |

5.1.4 Synchronous, asynchronous modes

5.1.4.1 Normal mode

ADC conversion can work in 4 different sampling modes (start, stop, continuous or filtered) according to the table below. Two bits per channel “SPCR1” and “SPCR0”, allocated in the Output Configuration Register “OUTCFGx”, allow 4 different sampling modes:

Table 39. Sampling mode configuration

| SPCR1 | SPCR0 | Sampling mode |
|-------|-------|-----------------|
| 0 | 0 | STOP mode |
| 0 | 1 | START mode |
| 1 | 0 | CONTINUOUS mode |
| 1 | 1 | FILTERED mode |

5.1.4.2 Synchronous mode

Synchronous mode in PWM condition

- Sampling is done according to the PWM rising and falling edge (see [Figure 21. Sequence of channels](#)). See [Table 39. Sampling mode configuration](#) for more details about the registers configuration.
- The sampling priority will be always allocated at higher priority.

Registers configuration

- SPCR10=0h: Synchronous triggered by rising edge on internal PWM. Conversion is executed on rising edge of conversion window (see [Figure 21. Sequence of channels](#)).
- ADC real sampling is managed to trigger the sampling point with margin versus falling edge.
- SPCR10=1h: Synchronous triggered by falling edge of the internal PWM signal. Conversion is executed on falling edge of conversion window (see [Figure 21. Sequence of channels](#)).

Note: ADC real sampling is managed to trigger the sampling point with margin versus rising edge.

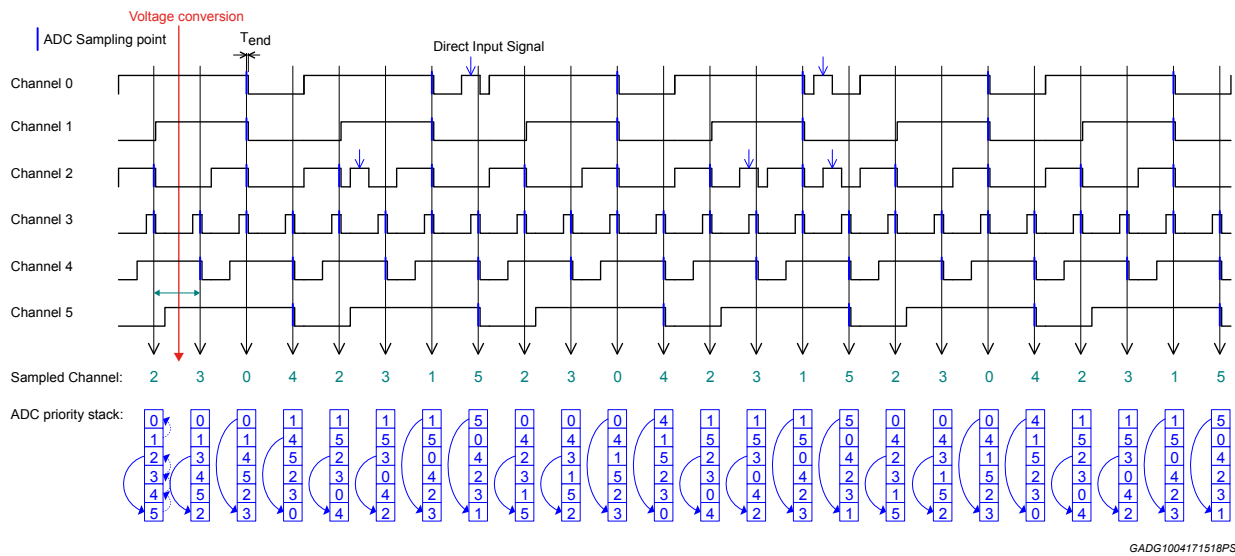
Figure 21. Sequence of channels

GADG1004171518PS

5.1.4.3 Asynchronous mode

In asynchronous mode the ADC result register is continuously refreshed, provided that the channel is commanded either through direct input signal or through SOCR register. Conversion is executed during the complete conversion window except the priority arbitration.

Since the ADC register is continuously refreshed, its conversion priority is always lower than sampled channels.

Once the PWM counter reaches a value for which synchronous diagnostics of another channel is requested, the internal MUX switches to this channel and serve the ADC sampling request (channels in synchronous mode have higher priority compared to those in asynchronous mode). Once this sampling is completed, the MUX switches back to the asynchronous sampling channel, provided that no higher priority sampling requests from other channels occur. If two or more channels are configured in asynchronous mode, the MUX sequentially switches through those channels, always interrupted when higher priority synchronous sampling requests occur.

The thermal case sampling has always low priority for the ADC conversion and so can be interrupted by any channel in sample mode.

Registers configuration:

SPCR10 = 2h and SOCRx = 1: asynchronous with continuous sampling:

Asynchronous mode, the ADC result register is continuously refreshed, provided that the channel is commanded either through the direct input signal or the SOCR register. Conversion is executed during the complete conversion window except for the priority arbitration. Since the ADC register is continuously refreshed, its conversion priority is always lower than sampled channels.

SPCR10 = 3h and SOCRx = 1: asynchronous with continuous sampling and digital LP filter:

- The integrated LP filter is activated
- This component filters data coming from the ADC conversion reducing the effect of random noise coming from the analog current sense amplifier

SPCR10 = 3h, SOCRx = x and DIx = high: if a channel is commanded off through SOCR, but commanded on through the direct input, the asynchronous sampling mode is forced - asynchronous with continuous sampling.

The thermal case sampling has always low priority for the ADC conversion, and so it can be interrupted by any channel in simple mode. Thermal case conversion is always in asynchronous continuous mode. In fail-safe condition the ADC conversion is always in asynchronous/continuous mode.

- Conversion is executed during the complete conversion window.
- No priority management is applied, channels are converted according to their position in the stack. No interruption and no priority management are possible. In the case of multiple channels active at the same time, the conversion starts with the first one in the stack.

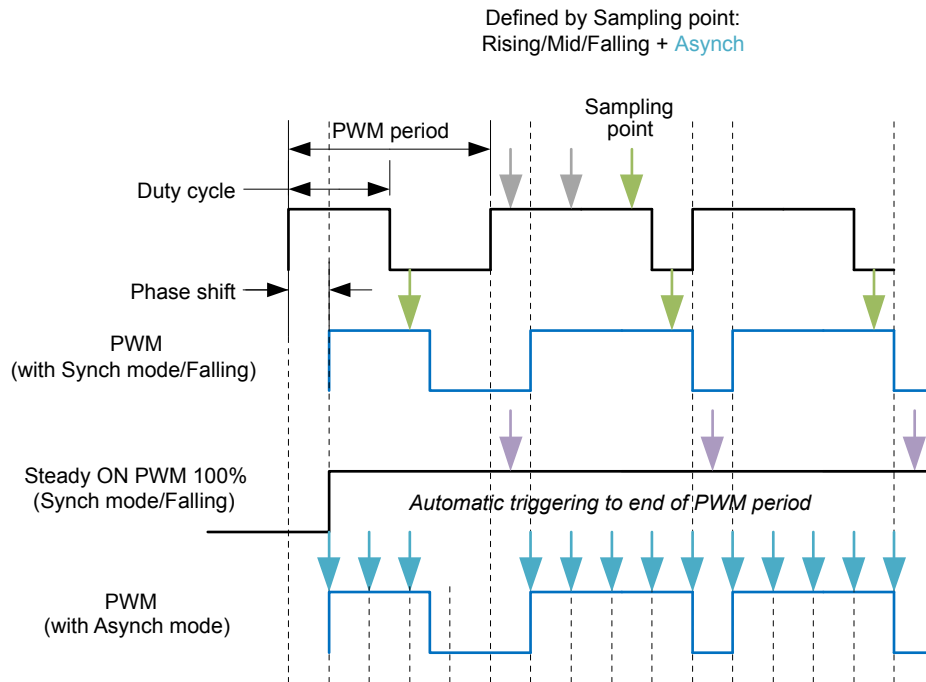
Figure 22. Asynchronous with continuous sampling

GADG311020171227MT

5.1.4.4 Sampling concept

- PWM mode (internal engine) → All the synchronous modes are available (start, stop, continuous or filtered)
- DC mode (internal engine) → ADC works in Continuous Mode. The conversion window follows the channel control input signal
 - DC mode by/without DI: No difference, since this condition is equivalent to PWM with 100% of duty (the sampling will be always in continuous mode).
- PWM mode by DI (external source) → the DIx information is combined (O-red) with the channel control signal. Sampling will be executed according to the PWM mode settings.
 - With SPCRx=2h,3h, sampling is possible (continuous/filtered mode).

5.1.4.5 Synchronous mode in DC condition (PWM with 100% duty cycle) – equivalent to asynchronous mode

This mode is equivalent to the asynchronous mode.

Table 40. ADC Configuration registers

| SOCrx | DIx | DutyCrx | SPCR1,0 | Conversion Mode | Feedback type |
|-------|-----|---------|---------|---|-----------------------|
| 1 | X | X | 00 | Synchronous triggered by falling edge on internal PWM | Output current |
| 1 | X | X | 01 | Synchronous triggered by rising edge of the internal PWM signal | Output current |
| 1 | X | X | 10 | Asynchronous with continuous sampling | Output current |
| 1 | X | X | 11 | Asynchronous with continuous sampling and digital LP filter | Output current |
| 0 | 1 | X | X | (Fail Safe Mode) Asynchronous with continuous sampling | Output current |
| X | X | X | X | Tframe conversion (Always lower priority than current sampled modes) | Tframe sensor voltage |

5.2 Integrated LP (Progressive Average) Filter

In asynchronous mode, when the filtered mode is selected through the dedicated bits “SPCR1=1” and “SPCR0=1”, the integrated LP filter is activated. This component will filter data coming from the ADC conversion reducing the effect of random noise coming from the analog Current Sense amplifier.

Features of the integrated LP filter:

- 1st order LP filter on 16 samples
- 1st result after 1 sample with progressive averaging of 16 successive samples

$$data(N) = \left(data(N-1) \cdot \frac{15}{16} \right) + data_i/16$$
- Continues to accumulate samples during PWM operation
- Keeps digitalized value when channel is turned off

5.3 Digital diagnostics

The global status byte (GSB) provides the preliminary status of device for every SPI communication with the device. It informs about the device actual mode (normal/fail-safe).

By reading the additional status registers, more detailed information is provided. Status information is stored in the status registers.

Figure 23. Status registers

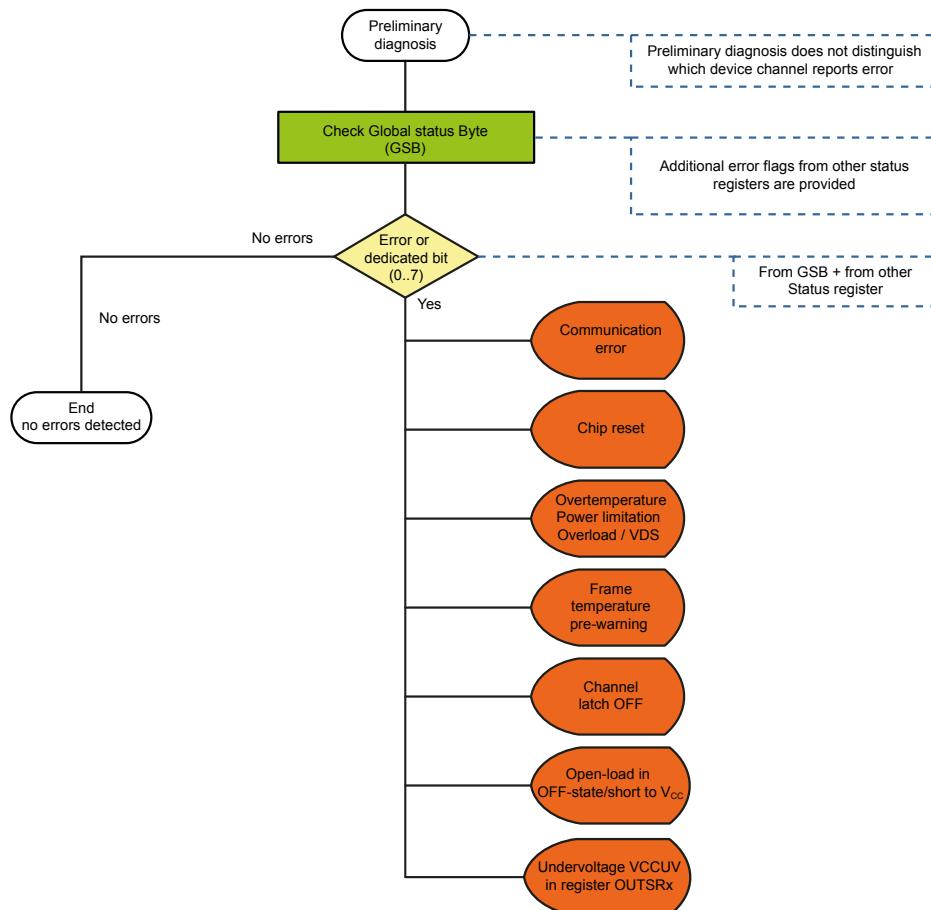

GADG311020171229MT

5.3.1 Status registers

Table 41. Status registers

| Address | Name | Access | Description |
|------------|--------|------------|---|
| 20h to 25h | OUTSR | Read/clear | Outputs status Register from 0x20h (channel 0) to 0x25h (channel 5) (see register map for detailed description) |
| 28h to 2Dh | ADCxSR | Read | Digital current sense registers. from 0x28h (channel 0) to 0x2Ch (channel 5) |
| 31h | ADC9SR | Read | Digital case temperature sensor current sense register. |

5.4 Overload (VDS high voltage, overload (OVL))

During low duty cycle PWM operation on a shorted load, the ON time is normally too short to allow power limitation or overtemperature detection, and the ADC output does not report the current flowing on the channel. In this situation, the detection of the overload condition is quite difficult. To overcome this, the voltage drop on the PowerMOS (V_{DS}) is measured every time the channel is turned OFF. If V_{DS} (voltage across PowerMOS output stage) exceeds the threshold defined by the parameter V_{DS_OVL} , an overload condition is detected. The corresponding bit in the overload status register VDSFSR (address from 0x20h to 0x23h depending on the channel) of the OUTSRx register is set (see the [Section 5.11: VDS feedback status bit \(VDSFSR\) in the OUTSRx register](#)).

Consequently, the bit 4 in the Global Status Byte is set if it is not masked in the CONFIG register through the dedicated "VDSMASK" bit. The VDSFSR is a warning and the channel can be switched on again even if the VDSFSRx bit is set. The VDSFSRx bit remains unchanged until a read and clear command on VDSFSR is sent by the SPI or until the output is turned off the next time, when the VDS is evaluated again. In case of low duty cycle PWM operation (i.e. 3% typical at 200 Hz in Bulb mode), if the output channel is switched ON for a very short time, V_{DS} might be greater than a threshold defined by the parameter V_{DS_OVL} even if the output is not in overload state so that a false warning is issued.

Figure 24. Diagnostics flowchart for digital overload detection

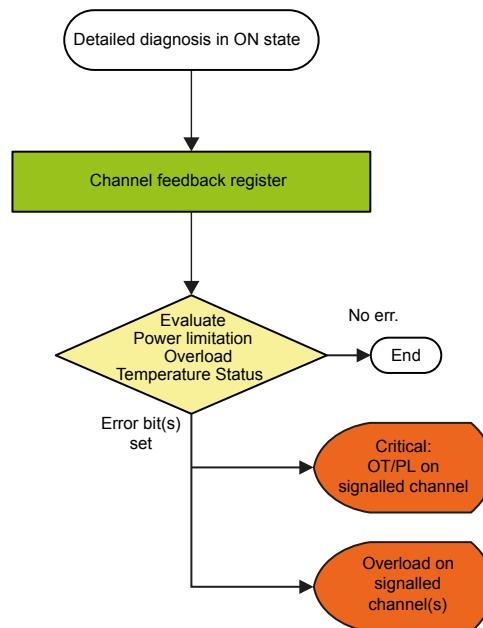

GADG1004171611PS

Please refer to [Section 4.3.1: Global Status byte description](#), [Section 5.8: CHFBSR: Channel Feedback Status bit in OUTSRx Register](#) and [Section 5.11: VDS feedback status bit \(VDSFSR\) in the OUTSRx register](#).

5.5 Open-load ON-state detection

The open-load ON-state is performed by reading the digital current sense. In case the output is on and the reported digital current sense value is below the requested defined threshold, the open-load condition can be reported.

5.6 Open-load OFF-state detection

After the channel is completely OFF, if the output voltage V_{out} exceeds the open-load detection threshold V_{OL} , an open-load in OFF state/stuck to V_{CC} event is reported.

As a consequence, the corresponding bit STKFLTR in the OUTSRx register (address 0x20 to 0x25) is set, the OL_{OFF} bit in the global status register and the global status bit are not set accordingly.

The STKFLTRx bit is set in OFF-state if $V_{OUT} > V_{OL}$ and the t_{DOLOFF} (turn-off delay time) is elapsed. It gives information about the open-load or a stuck to V_{CC} that depends on the configuration of the OUTCTRCRx OLOFFCR bit. The bit is continuously refreshed in OFF-state and it is latched during ON-state. In order to clear the bit in ON-state, it is necessary to send a Read and Clear command.

STKFLTRx=1: Open-load in OFF-state or stuck to V_{CC} condition occurred for OUTPUTx

STKFLTRx=0: No fault detected

To avoid false detection, the diagnosis starts after turn-off of a channel with an additional delay t_{DOLOFF} . To distinguish between an open-load OFF-state event and a short to V_{CC} condition, an internal pull-up current generator can be enabled for each channel by setting the corresponding open-load off state bit OL_{OFFCR} (bit 2) in the outputs control registers "OUTCTRCR"(address from 0x00 to 0x05 depending on the channel).

The activated pull-up current generators are active in normal mode, in fail-safe mode, and in standby mode.

Differently, in sleep mode 2 the current generators are switched off. The register contents, however, are saved also in sleep mode 2 and consequently the current generators are reactivated after a return to standby or a wake up to fail-safe mode. A hardware reset ($V_{DD} < V_{DD_POR_OFF}$) or a software reset (command byte = FFh) clears all register contents and hence the current generators are switched off.

Figure 25. Open-load OFF-state detection

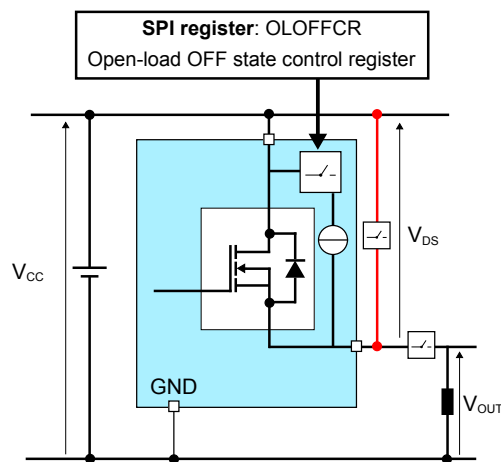

GADG1004171620PS

Table 42. STKFLTR state

| | With internal pull-up generator | Without internal pull-up generator |
|------------------------------------|---------------------------------|------------------------------------|
| Case 1: load connected | "0" / no fault | "0" / no fault |
| Case 2: no load | "1" / fault | "0" / no fault |
| Case 3: output shorted to V_{CC} | "1" / fault | "1" / fault |

Figure 26. Diagnostics flowchart for open-load off-state respectively stuck to V_{CC} failure

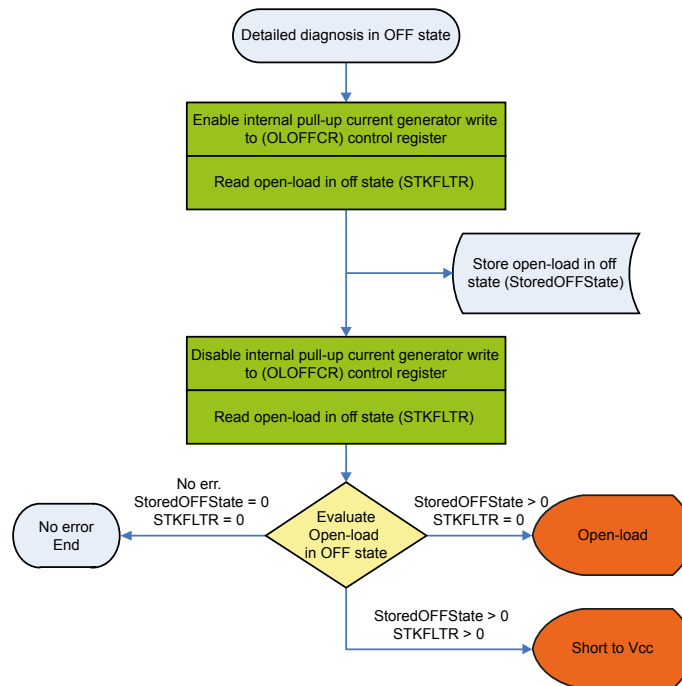

GADG1004171628PS

5.7 DIENSR: direct input status bit in OUTSRx register (address from 0x20 to 0x25)

DIENSR bits read back the logic level of the D_{ix} input assigned through OTP to the specific channel. The D_{ix} pin is used to control the outputs channel in case of fail-safe condition or in normal operation if the related “DIENCR” bit set.

5.8 CHFBSR: Channel Feedback Status bit in OUTSRx Register

The CHFBSRx provides a logical "OR" combination of VDS (overload), PL (power limitation), OT (over temperature) failure flags related to OUTPUTx. The contributions of VDS failure flags to the channel feedback status register and Global Status Byte can be mask-able through VDSmaskx bit in OUTCFGRx registers.

CHFBSRx = 1: Channel OUTPUTx on failure

CHFBSRx = 0: Channel OUTPUTx no failure

The bits are refreshed continuously in ON-state and latched in OFF-state.

In order to clear the bit in OFF-state, it is necessary to send a Read-Clear command.

5.9 Open-load in OFF-State / Stuck to V_{CC} Status bit "STKFLTR" in OUTSRx register

This bit is set when the output voltage of the selected channel exceeds the detection threshold at turn-OFF.

The STKFLTRx bit is set in OFF-state if $V_{OUT} > V_{OL}$ and the t_{DOLOFF} (turn-off delay time) is elapsed. It gives information about open load or a stuck to V_{CC} which depends on the configuration of the OUTCTRCRx OLOFFCR bit register. The bit is continuously refreshed in OFF-state and it is latched during ON-state. In order to clear the bit in ON-state it is necessary to send a Read and Clear command.

STKFLTRx=1: Open-load in OFF-state or stuck to V_{CC} condition occurred for OUTPUTx

STKFLTRx=0: No fault detected

5.10 Channels latch-off status bit (CHLOFFSR) in OUTSRx register

The CHLOFFSR bit is set as soon as there is a fault condition identified as Power-limitation or over-temperature.

Latch OFF flag register. There is one bit per channel.

In case that the latch-off condition occurs, the faulty channel can be reactivated after clearing the related CHLOFFSR bit through a write operation. A SW reset event clears the content of the register.

5.11 VDS feedback status bit (VDSFSR) in the OUTSRx register

This bit represents the VDS Feedback status. The device is equipped with one VDS bit per channel.

The bit is set in case that an overload condition is detected on the related channel. The bit is set independently of the OT.PL. flag.

The VDSFSRx bit is set if, at the instant when the channel is commanded off or is latched off, the V_{CC} - V_{OUT} voltage drop exceeds the V_{DS_OVL} threshold. The bit is latched until the next turn OFF. In order to clear the bit, it is necessary to send a read and clear command.

The VDSFSRx bit is set to:

1: overload event occurred for OUTPUTx

0: no fault detected

Note: As the status register is not updated while CSN is low, it is possible that the update of the VDSFSR is delayed until the next time it is commanded off, if the PowerMOS is turned off during an SPI-frame.

The contributions of "VDSFSR" failure flags to the channel feedback status register and Global Status Byte can be mask-able through the VDSmaskx bit in OUTCFGRx registers.

6 Programmable blanking window (PBW)

Dedicated registers (CHLOFFTCR1 and CHLOFFTCR0) provide a variable and programmable blanking window in case of power limitation or overtemperature event for each channel. During this period, the corresponding channel is in auto-restart mode and the channel is allowed to stay in power-limitation and/or overtemperature state before latching off, once blanking time is expired, if the cause of the power limitation or overtemperature event is still present. In this case the channel latches off and the related flag in the latch-off error register (CHLOFFSR) is set. Latch-off flag is also reported in the Global Status Byte (see [Section 4.3.1: Global Status byte description](#)).

If during the blanking time the cause of the power limitation and/or overtemperature event disappears, the timer stops, then the rest of the blanking time will be available for another power limitation and/or overtemperature event. Therefore it is up to the MCU to reset the timer by refreshing the programmed value in the dedicated register (CHLOFFTCR1 or CHLOFFTCR0).

The MCU can keep the device in auto-restart forever artificially by refreshing the programmed blanking time.

6.1 Timer

The 4-bit value per channel written in the registers CHLOFFTCR1 or CHLOFFTCR0 is translated internally into an 8-bit value. The four MSBs of this 8-bit value correspond to the content of CHLOFFTCRx register, while the four LSBs are filled with 0xF. The 8-bit value refers to an analog timer value.

Figure 27. Internal timer process

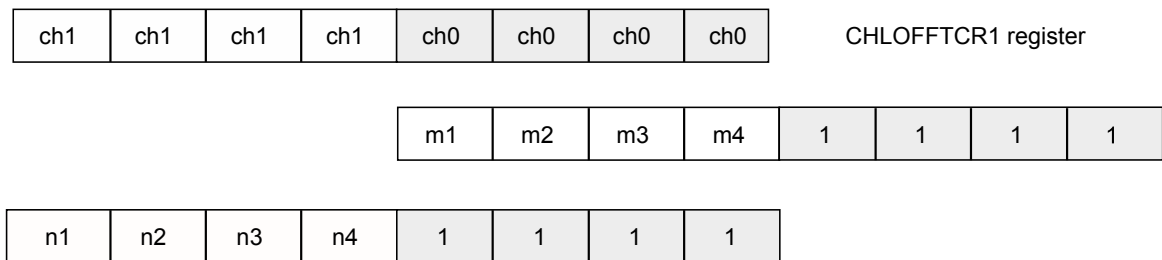

GADG311020171233MT

The granularity of the 8-bit counter is t_{STEP} . At each power limitation or overtemperature event, the 8-bit counter is decreased by the number of steps equal to the duration of power limitation or overtemperature event. If the power limitation or overtemperature phase lasts for less than t_{STEP} the counter is decreased by one step.

After each downcount of the 8-bit register, the 4 MSB bits will be transferred to the 4 bits of the corresponding CHLOFFTCRx register in order to refresh this register to the new value of the timer. The microcontroller can read only the 4 MSB bits content of the register. In consequence, the microcontroller can detect a change of every 16 steps of downcounting.

The timer counts down if the flag is set as consequence of a power limitation or overtemperature event. At the end of the timer's step, the flag is checked. It will be reset if the event is not present.

The timer stops counting down each time the event disappears or if the channel is turned into OFF state. This does not include the one step counting if the flag is set for the first time. If the event is not present, the timer will stop counting down and will reset the flag.

In case that the timer reaches the ZERO, the system goes to the latching off state and the related flag in the latch-off error register is set.

Downcounting is stopped and the content of the 8-bit counter is frozen when the channel is commanded off through direct input or the SOCR register. The timer can stay with an already down-counted value for a long time. It is up to the MCU to reset it.

The MCU can keep the device in auto-restart forever mode artificially by refreshing the timer register value not to reach zero.

The following figure is related to the one timer step. The actions are performed after the rising and falling edges.

Figure 28. One timer step actions

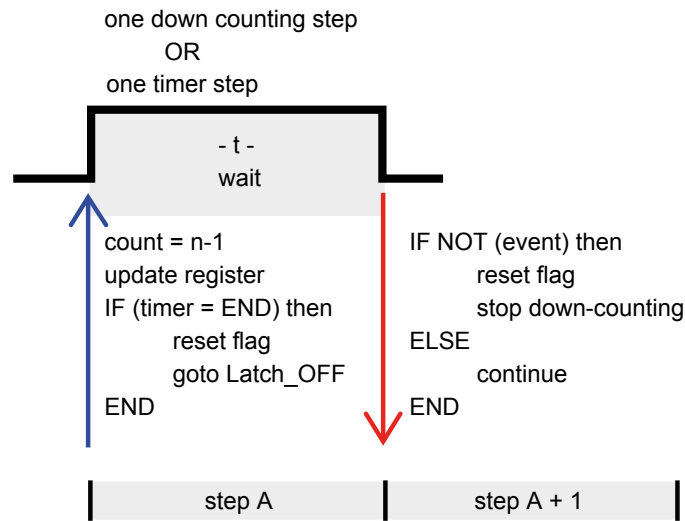

GADG311020171234MT

6.2 Blanking window values

The range of the configurable blanking window is shown in Table 43. Time values written by MCU and their real value in timer register.

Blanking window reserved values:

- 0x0: It configures the channel in Latch-Off mode without blanking time. Consequently, the channel will latch-off upon the first occurrence of power limitation or overtemperature event.
- 0x1 to 0xF: This value represents the time duration, it will be written by the MCU in the register (Latch-Off timer register) "CHLOFFTCRx" (Address 0x10h and 0x11h). During this time, the device is allowed to stay in power-limitation and/or over-temperature state before latching off if the "event" is still active or present. The minimum value of the timer, known as Zero, is 0x0F. When the timer reaches this value the latch-off action will be triggered

The following table shows the time values written by MCU and their real value in timer register.

Table 43. Time values written by MCU and their real value in timer register

| Bit 7 or bit 3 | Bit 6 or bit 2 | Bit 5 or bit 1 | Bit 4 or bit 0 | 0xm | 0xmF | Typical value of blanking time |
|----------------|----------------|----------------|----------------|-----|------|--------------------------------|
| 0 | 0 | 0 | 0 | 0x0 | 0x0F | Latch-Off (ZERO) |
| 0 | 0 | 0 | 1 | 0x1 | 0x1F | 16 ms |
| 0 | 0 | 1 | 0 | 0x2 | 0x2F | 32 ms |
| 0 | 0 | 1 | 1 | 0x3 | 0x3F | 48 ms |
| | | | | 0x4 | 0x4F | 64 ms |
| | | | | ... | ... | ... |
| 1 | 1 | 1 | 0 | 0xE | 0xEF | 224 ms |
| 1 | 1 | 1 | 1 | 0xF | 0xFF | 240 ms |

6.3 Power limitation counter

The flowchart below displays the flow of the events and states. It does not include the timer update by MCU.

Figure 29. Power limitation counter flowchart

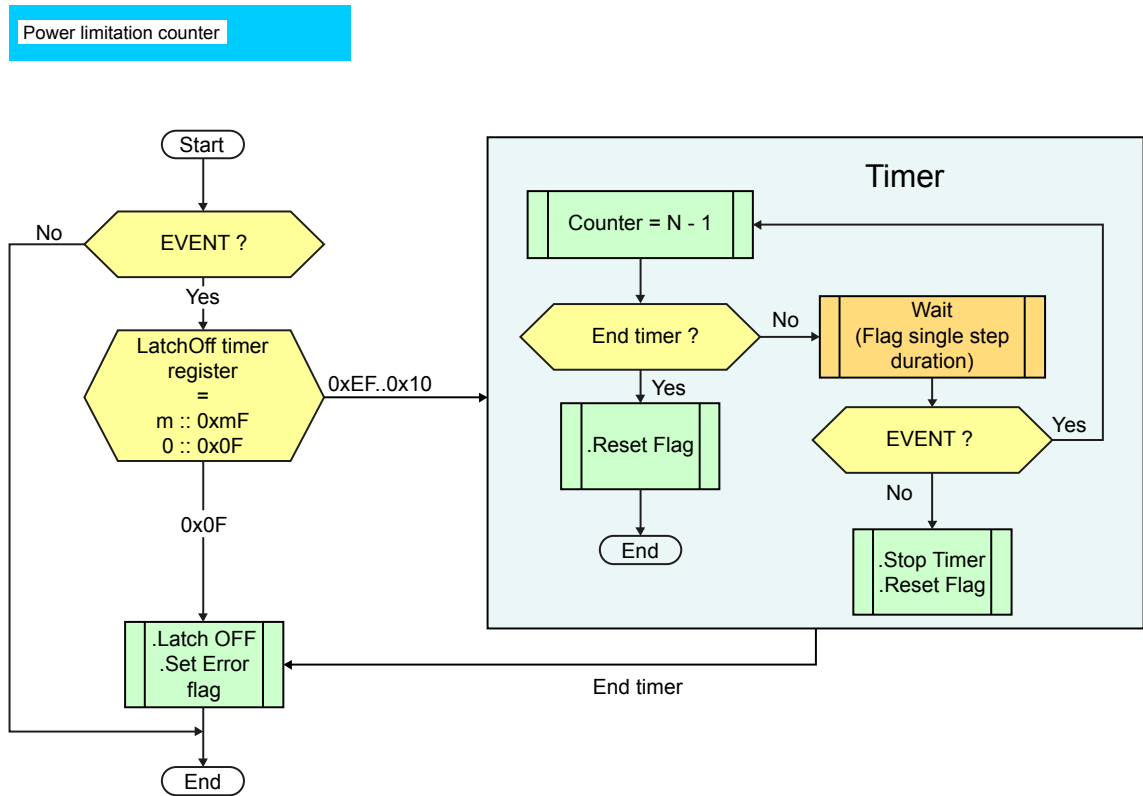

GAD/G311020171235MT

6.4 Limp-home mode

In limp-home mode, the device is in unlimited auto restart operation. The blanking time window has no effect on the duration of the auto restart. The timers in the limp-home mode are frozen and are inactive. This guarantees full independence of the limp-home mode operation.

6.5 Registers

For more details refer to the SPI register and Diagnostics.

- Address 0x10h - Channel Latch OFF Timer Control Register (CHLOFFTCR0)
- Address 0x11h - Channel Latch OFF Timer Control Register (CHLOFFTCR1)

Two 16-bit registers (Latch-OFF timer: R/W) are used for channel behavior configuration and the timer value settings.

For each channel 4 bits are used. The value is written by MCU from 0x0 to 0xF.

Figure 30. Example of behavior channel configuration

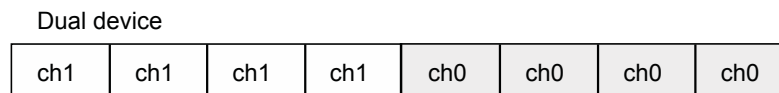

GADG311020171236MT

Latch-off timer register access

- **Write command** – store new value, read-back (during write command) old value equal to the timer down-counting.
 - Any write command will clear the flag in the latch-OFF flag register and reset the timer.
 - This function will be used by MCU to clear the flag in the Latch-OFF flag register, which is read only register.
- **Read command** – reads currently down-counted timer value. If the channel was latched due to the timer expiration, the channel is kept latched after read command.
- **Channels latch-off status bit – CHLOFFSRx in OUTSRx** (Address 0x20 to 0x25 depending on the channel) Each channel has one CHLOFFSR flag. In case of latch-OFF of a channel, this flag will be set and be readable by the MCU. This bit must be cleared to allow the channel to resume operation through a read/clear operation.

7 Electrical specifications

7.1 Absolute maximum ratings

Stressing the device above the rating listed in the Table 44. Absolute maximum ratings may cause permanent damage to the device. These are stress ratings only and operation of the device at these or any other conditions above those indicated in the operating sections of this specification is not implied. Exposure to absolute maximum rating conditions for extended periods may affect device reliability.

Table 44. Absolute maximum ratings

| Symbol | Parameter | Value | Unit | |
|-----------------------|---|--------------------|------|---|
| $V_{CC\ LSC}$ | Maximum supply voltage for full short-circuit protection | 18 | V | |
| V_{CCJS} | Maximum jump start voltage for single pulse short circuit protection | 28 | V | |
| V_{CC} | DC supply voltage | 36 | V | |
| $-V_{CC}$ | Reverse DC supply voltage | 16 | V | |
| $I_{OUT0,1,2,3,4,5}$ | Maximum DC output current | Internally limited | A | |
| $-I_{OUT0,1,2,3,4,5}$ | Reverse DC output current | 6.6 | A | |
| I_{PWM_CLK} | DC current sense input current | +3/-1 | mA | |
| V_{SDO} | DC SPI pin voltage | $V_{DD} + 0.3$ | V | |
| $-V_{SDO}$ | Reverse DC SPI pin voltage | 0.3 | V | |
| $I_{SDI,CSN,SCK}$ | DC SPI pin current | +10/-1 | mA | |
| I_{DD} | DC digital control supply current | +10/-1 | mA | |
| V_{DD} | DC digital control supply | 6 | V | |
| $-V_{DD}$ | Reverse DC digital control supply | 0.3 | V | |
| $IDIN0,1$ | DC direct input current | +10/-1 | mA | |
| E_{MAX} | Maximum switching energy (single pulse); $T_{Jstart} = 150\text{ °C}$, Ch1- 5, Bulb mode | 12.1 | mJ | |
| | Maximum switching energy (single pulse); $T_{Jstart} = 150\text{ °C}$, Ch1- 5, LED mode | 4.7 | | |
| ESD | Electrostatic discharge (ANSI-ESDA-JEDEC-JS-001-2014) | DI0,1 | 2000 | V |
| | | V_{DD} | 2000 | |
| | | PWM_CLK | 2000 | |
| | | CSN, SDI, SCK,SDO | 2000 | |
| | | OUT0,1,2,3,4,5 | 4000 | |
| | | V_{CC} | 4000 | |
| T_J | Operating junction temperature range | -40 to 150 | °C | |
| T_{stg} | Storage temperature range | -55 to 150 | °C | |
| I_{LAT} | Latch up current | ±20 | mA | |

7.2 Thermal data

Table 45. Thermal data

| Symbol | Parameter | Typ. value | Unit |
|-------------------|--|---|------|
| R _{thJB} | Thermal resistance, junction-to-board (JEDEC JESD 51-5 / 51-8) ⁽¹⁾⁽²⁾ | 8.8 | °C/W |
| R _{thJA} | Thermal resistance, junction-to-ambient | See Figure 44. R _{thJA} vs PCB copper area in open box free air conditions | °C/W |

1. Device mounted on four-layers 2s2p PCB.
2. One channel ON.

7.3 SPI electrical characteristics

 Mode 1: $2.7\text{ V} < V_{DD} < 5.5\text{ V}$, $-40\text{ }^{\circ}\text{C} < T_J < 150\text{ }^{\circ}\text{C}$, unless otherwise specified.

Table 46. DC characteristics

| Symbol | Parameter | Test conditions | Min. | Typ. | Max. | Unit |
|-------------------------------|--|---|---------------------|------|---------------------|------|
| V_{DD} pin | | | | | | |
| V _{DD_POR_ON} | Power-on reset threshold. Device leaves the Reset mode. Supply of digital part is reset. | V _{DD} increasing; V _{CC} > V _{USD} | 1.65 | 2.15 | 2.65 | V |
| V _{DD_POR_OFF} | Power-on shutdown threshold. Device enters Reset mode. Supply of digital part in shutdown. | V _{DD} decreasing; V _{CC} > V _{USD} | 1.4 | 1.9 | 2.4 | V |
| V _{POR_HYST} | Power-on reset hysteresis | | | 0.2 | | V |
| I _{DD} | Digital part supply current in normal mode | V _{DD} = 5 V; SPI active without frame communication | | 1 | 1.5 | mA |
| I _{DDstd} at 5 V | Digital part supply current in standby state | V _{DD} = 5 V, T _J = 125 °C, I _{Nx} = 0 V | | 5 | 35 | μA |
| SDI, SCK, PWM_CLK pins | | | | | | |
| I _{IL} | Low level Input current | V _{SDI,SCK} = 0.3 V _{DD} | 1 | | 10 | μA |
| I _{IH} | High level Input current | V _{SDI,SCK} = 0.7 V _{DD} | 1 | | 10 | μA |
| V _{IL} | Input low voltage | | | | 0.3 V _{DD} | V |
| V _{IH} | Input high voltage | | 0.7 V _{DD} | | | V |
| V _{I_HYST} | Input hysteresis voltage | | | 0.5 | | V |
| V _{PWM_CLK} | PWM_CLK clamping voltage | I _{IN} = 3 mA | 9 | | 15 | V |
| | | I _{IN} = -1 mA | | -0.7 | | V |
| V _{SDI_CL} | SDI clamping voltage | I _{IN} = 1 mA | 6 | | 8.2 | V |
| | | I _{IN} = -1 mA | | -0.7 | | V |
| V _{SCK_CL} | SCK clamping voltage | I _{IN} = 1 mA | 6 | | 8.2 | V |
| | | I _{IN} = -1 mA | | -0.7 | | V |
| SDO pin | | | | | | |
| V _{OL} | Output low voltage | I _{SDO} = -5 mA; CSN low; fault condition | | | 0.2 V _{DD} | V |
| V _{OH} | Output high voltage | I _{SDO} = 5 mA; CSN low, no fault condition | 0.8 V _{DD} | | | V |
| I _{LO} | Output leakage current | V _{SDO} = 0 V or V _{DD} , CSN high | -5 | | 5 | μA |
| CSN pin | | | | | | |
| I _{IL_CSN} | Low level Input current | V _{CSN} = 0.3 V _{DD} | -10 | | -1 | μA |
| I _{IH_CSN} | High level Input current | V _{CSN} = 0.7 V _{DD} | -10 | | -1 | μA |
| V _{IL_CSN} | Output low voltage | | | | 0.3 V _{DD} | V |
| V _{IH_CSN} | Output high voltage | | 0.7 V _{DD} | | | V |
| V _{HYST_CSN} | Input hysteresis voltage | | | 0.5 | | V |
| V _{CL_CSN} | CSN clamping voltage | I _{IN} = 1 mA | 6 | | 8.2 | V |
| | | I _{IN} = -1 mA | | -0.7 | | V |

Table 47. AC characteristics (SDI, SCK, CSN, SDO, PWM_CLK pins) - Mode 1

| Symbol | Parameter | Test conditions | Min. | Typ. | Max. | Unit |
|-----------|--------------------------------|--------------------------------------|------|------|------|------|
| C_{OUT} | Output capacitance (SDO) | $V_{OUT} = 0\text{ V to }5\text{ V}$ | - | - | 10 | pF |
| C_{IN} | Input capacitance (SDI) | $V_{IN} = 0\text{ V to }5\text{ V}$ | - | - | 10 | pF |
| | Input capacitance (other pins) | $V_{IN} = 0\text{ V to }5\text{ V}$ | - | - | 20 | pF |

Table 48. Dynamic characteristics

| Symbol | Parameter | Test conditions | Min. | Typ. | Max. | Unit |
|-------------------|---|-------------------------|------|------|------|---------------|
| f_C | Clock frequency | Duty cycle = 50% | 0 | | 8 | MHz |
| t_{WHCH} | CSN timeout: time to release SDO bus | | 30 | | 70 | ms |
| t_{WDTB} | Watchdog toggle bit timeout | | 30 | | 70 | ms |
| t_{SLCH} | CSN low setup time | | 60 | | | ns |
| t_{SHCH} | CSN high setup time | | 600 | | | ns |
| t_{DVCH} | Data in setup time | | 10 | | | ns |
| t_{CHDX} | Data in hold time | | 15 | | | ns |
| t_{CH} | Clock high time | | 60 | | | ns |
| t_{CL} | Clock low time | | 60 | | | ns |
| t_{CLQV} | Clock low to output valid | $C_{OUT} = 1\text{ nF}$ | | 75 | | ns |
| t_{QLQH} | Output rise time | $C_{OUT} = 1\text{ nF}$ | | 55 | | ns |
| t_{QHQL} | Output fall time | $C_{OUT} = 1\text{ nF}$ | | 55 | | ns |
| t_{WU} | Rising edge of V_{DD} to first allowed communication | | 3 | | 23 | μs |
| t_{stdby_out} | Minimum time during which CSN must be toggled low to go out of STDBY mode | | 20 | 65 | 150 | μs |
| $t_{SCLK}^{(1)}$ | SCK setup time before CSN rising | | 20 | | | ns |
| $t_{CSNQV}^{(1)}$ | CSN low to output valid | | | | 200 | ns |
| $t_{CSNQT}^{(1)}$ | CSN high to output tristate | | | | 200 | ns |

1. Parameter specified by design, not tested in production.

Figure 31. SPI dynamic characteristics

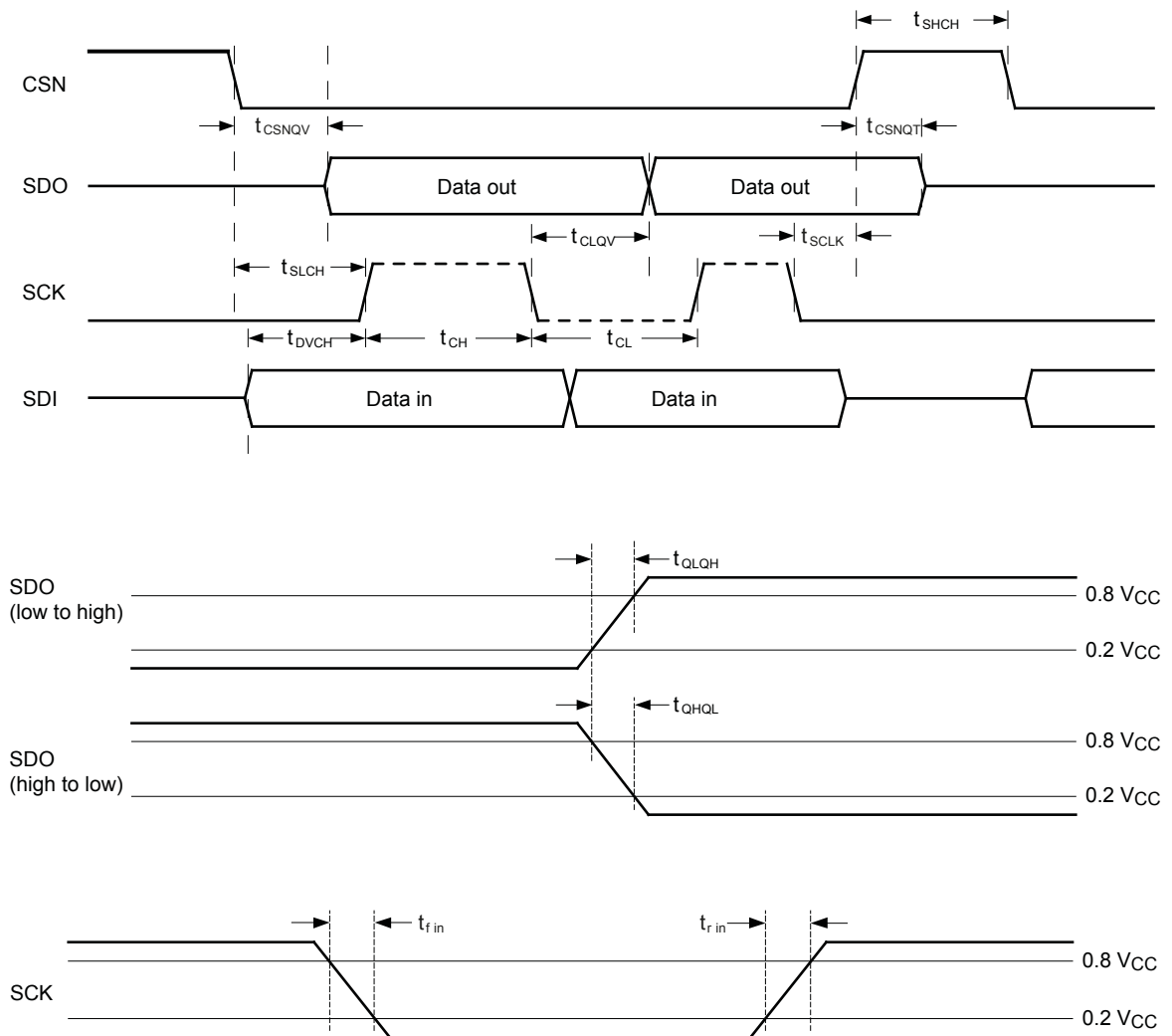

GADG311020171237MT

7.4 Electrical characteristics

7 V < V_{CC} < 28 V; -40 °C < T_J < 150 °C, unless otherwise specified.

Table 49. Power section

| Symbol | Parameter | Test conditions | Min. | Typ. | Max. | Unit |
|----------------------|---|--|------|------|------|------|
| V _{CC} | Operating supply voltage | | 4 | 13 | 28 | V |
| -V _{CC} | Reverse DC supply voltage | | | 13 | | V |
| V _{USD} | Undervoltage shutdown | | | 2 | 2.7 | V |
| V _{USDhyst} | Undervoltage shutdown hysteresis | | | 0.1 | | V |
| V _{clamp} | V _{CC} clamp voltage | I _{CC} = 20 mA; I _{OUT0,1,2,3} = 0 A; T _J = -40 °C | 35 | | | V |
| | | I _{CC} = 20 mA; I _{OUT0,1,2,3} = 0 A; 25 °C < T _J < 150 °C | 35 | 38 | 45 | V |
| I _S | Supply current | Sleep mode1; V _{CC} = 13 V; T _J = 25 °C; V _{DD} = 0 V | | 0.1 | 0.5 | μA |
| | | Sleep mode2; V _{CC} = 13 V; T _J = 25 °C; V _{DD} = 5 V | | 0.1 | 0.5 | μA |
| | | ON-state (all channels OFF); V _{CC} = 13 V; V _{DD} = 5 V; I _{OUT} = 0 A | | 2.3 | 3.3 | mA |
| ΔI _{son} | Additional supply current for each output in ON state driving nominal current | ON-state (per channel), V _{CC} = 13 V, V _{DD} = 5 V, I _{OUT0,1,2,3,4,5} = 2.1 A | | | 1.7 | mA |
| I _{L(off)} | OFF-state output current | V _{DD} = 0 V; V _{CC} = 13 V; T _J = 25 °C | 0 | 0.01 | 0.5 | μA |
| | | V _{DD} = 0 V; V _{CC} = 13 V; T _J = 125 °C; Ch0,1,2,3,4,5 (per channel) | 0 | | 0.6 | μA |
| V _F | Output V _{CC} diode voltage | V _{CC} = 13 V; I _{OUT} = 2.1 A; T _J = 150 °C | | | 0.7 | V |

Table 50. Logic inputs (DI0,1 pins)

| Symbol | Parameter | Test conditions | Min. | Typ. | Max. | Unit |
|-----------------------------|--------------------------|--------------------------|------|------|------|------|
| V _{IL0,1} | Input low level voltage | | | | 0.9 | V |
| I _{IL0,1} | Low level input current | V _{DIN} = 0.9 V | 1 | | | μA |
| V _{IH0,1} | Input high level voltage | | 2.1 | | | V |
| I _{IH0,1} | High level input current | V _{DIN} = 2.1 V | | | 10 | μA |
| V _{I(hyst)0,1,2,3} | Input hysteresis voltage | | 0.2 | | | V |
| V _{ICL0,1} | Input clamp voltage | I _{IN} = 1 mA | 6 | | 8.2 | V |
| | | I _{IN} = -1 mA | | -0.7 | | V |

Table 51. Protection

| Symbol | Parameter | Test conditions | Min. | Typ. | Max. | Unit |
|-------------------------|---|--|---------------------|---------------------|---------------------|------|
| $\Delta T_{PLIM}^{(1)}$ | Junction-case temperature difference triggering power limitation protection | $V_{CC} = 16\text{ V}$ | | 80 | | °C |
| | | $V_{CC} = 19\text{ V}$ | | 55 | | |
| ΔT_{PLIMR} | Junction-case temperature difference resetting power limitation protection | $V_{CC} = 16\text{ V}$ | | 58 | | °C |
| | | $V_{CC} = 19\text{ V}$ | | 33 | | |
| T_{TSD} | Shutdown temperature | $V_{CC} = 13\text{ V}$ | 150 | 175 | 210 | °C |
| | Shutdown temperature (V_{CC} decreasing) ⁽²⁾ | $V_{CC} = 2.7\text{ V}$ | 140 | | | |
| T_{RS} | Thermal reset of CHFBSR fault detection ⁽²⁾ | $V_{CC} = 13\text{ V}$, latched off mode disabled | 135 | | | °C |
| T_{HYST} | Thermal hysteresis ($T_{TSD} - T_R$) ⁽²⁾ | $V_{CC} = 13\text{ V}$, latched off mode disabled | | 10 | | °C |
| T_{CSD} | Case thermal detection pre-warning ⁽²⁾ | $V_{CC} = 13\text{ V}$ (see CTRL) | $T_{CSD\ nom} - 10$ | $T_{CSD\ nom}$ | $T_{CSD\ nom} + 10$ | °C |
| T_{CR} | Case thermal detection reset ⁽²⁾ | $V_{CC} = 13\text{ V}$ | | $T_{CSD\ nom} - 10$ | | °C |
| V_{DS_OVL} | V_{DS} overload detection threshold | | $V_{CC} - 2$ | $V_{CC} - 1.5$ | $V_{CC} - 1$ | V |
| $t_{Blanking}$ | Programmable blanking time | | 14.4 | | 264 | ms |
| $t_{D_Restart}$ | Latch-OFF delay time before automatic restart | | | 55 | | ms |
| $t_{D_GSB_UPDATE}$ | Status register update filtering time | | 1.4 | 2.0 | 2.6 | ms |
| t_{ON_MIN} | Minimum turn-on time per channel to avoid false V_{DS} error flag | Bulb mode, ch0,1,2,3,4,5 | | | 200 | µs |
| | | LED mode, ch0,1,2,3,4,5 | | | 100 | µs |

- $Z_{th\text{-case}} \times P = \Delta T_{PLIM}$, $Z_{th\text{-case}}$ is the thermal impedance, P is the Power.
- Parameter specified by design and evaluated by characterization, not tested in production.

Table 52. Open-load detection (7 V < V_{CC} < 18 V)

| Symbol | Parameter | Test conditions | Min. | Typ. | Max. | Unit |
|--------------|--|---|--------------|----------------|--------------|------|
| V_{OL} | Open-load OFF-state voltage detection threshold | CHx off | $V_{CC} - 2$ | $V_{CC} - 1.5$ | $V_{CC} - 1$ | V |
| I_{PU} | Pull-up current generator for open-load at OFF-state detection | Pull-up current generator active, $V_{OUT} = V_{CC} - 1.0\text{ V}$ | -0.5 | -1 | -1.5 | mA |
| t_{DOLOFF} | Delay time after turn off to allow open-load OFF-state detection | | 85 | 175 | 265 | µs |

7.5 PWM unit

$2.7\text{ V} < V_{DD} < 5.5\text{ V}$; $-40\text{ }^{\circ}\text{C} < T_J < 150\text{ }^{\circ}\text{C}$, unless otherwise specified.

Table 53. PWM unit

| Symbol | Parameter | Test conditions | Min. | Typ. | Max. | Unit |
|------------------|--------------------------|-------------------|------|------|------|---------------|
| PWM_Res | PWM resolution | PWM_Divider_1,2,3 | | | 0.1 | % |
| | | PWM_Divider_4 | | | 0.2 | % |
| PWM_Clk | PWM clock range | | 300 | 400 | 500 | kHz |
| PWM_Clk_flbk | PWM clock fallback | | 300 | 400 | 500 | kHz |
| PWM_Clk_flbk_del | PWM clock fallback delay | | 20 | | 40 | μs |

Note: **PWMCLOCKLOW** warning flag is set only when the period of the clock signal externally applied to **PWM_CLK** pin is longer than **PWM_Clk_flbk_del**.
 Consequently, if the **PWM_CLK** frequency is higher than 50 kHz (corresponding to a period of 20 μs , which is the minimum value of **PWM_Clk_flbk_del**) this flag is never set.
 When **PWMCLOCKLOW** warning flag is set, an internal fallback clock (at a typical frequency of 400 kHz) is used to substitute the external one.

7.6 BULB mode

Table 54. BULB - power section

| Symbol | Parameter | Test conditions | Min. | Typ. | Max. | Unit |
|----------------|---|---|------|------|------|------------|
| $R_{ON}^{(1)}$ | ON-state resistance | $I_{OUT} = 2.1\text{ A}$; $T_J = 25\text{ }^{\circ}\text{C}$ | - | 32 | | m Ω |
| | | $I_{OUT} = 2.1\text{ A}$; $T_J = 150\text{ }^{\circ}\text{C}$ | - | | 70 | |
| | | $I_{OUT} = 2.1\text{ A}$; $V_{CC} = 4\text{ V}$; $T_J = 25\text{ }^{\circ}\text{C}$ | - | | 40 | |
| | | $I_{OUT} = 1\text{ A}$; $V_{CC} = 2.9\text{ V}$; V_{CC} decreasing | - | | 200 | |
| R_{ON_REV} | On-state resistance in reverse battery ⁽¹⁾ | $I_{OUT} = -2.1\text{ A}$; $V_{CC} = 13\text{ V}$; $T_J = 25\text{ }^{\circ}\text{C}$ | - | 32 | | m Ω |

1. For each channel.

Table 55. BULB - switching ($V_{CC} = 13\text{ V}$; normal switch mode)

| Symbol | Parameter | Test conditions | Min. | Typ. | Max. | Unit |
|----------------------------|--|--|------|------|------|------------------|
| $t_{don}^{(1)}$ | Turn-on delay time Ch0-5 at $T_J = 25\text{ }^{\circ}\text{C}$ to $150\text{ }^{\circ}\text{C}$ | Fail-safe mode, Bulb mode, from Dlx rising to 20% V_{OUT} ; $R_L = 6.2\text{ }\Omega$ SLOPECRx = 00 | 21 | 33 | 46 | μs |
| $t_{doff}^{(1)}$ | Turn-off delay time Ch0-5 at $T_J = 25\text{ }^{\circ}\text{C}$ to $150\text{ }^{\circ}\text{C}$ | Fail-safe mode, Bulb mode, from Dlx falling to 80% V_{OUT} ; $R_L = 6.2\text{ }\Omega$ SLOPECRx = 00 | 17 | 30 | 43 | μs |
| $t_{skew}^{(1)}$ | Turn-off turn-on delay time Ch0-5 at $T_J = 25\text{ }^{\circ}\text{C}$ to $150\text{ }^{\circ}\text{C}$ | Differential Pulse skew ($t_{pHL} - t_{pLH}$); $R_L = 6.2\text{ }\Omega$ | -50 | 0 | 50 | μs |
| $(dV_{OUT}/dt)_{on}^{(1)}$ | Turn-on voltage slope Ch0-5 at $T_J = 25\text{ }^{\circ}\text{C}$ to $150\text{ }^{\circ}\text{C}$ | $V_{OUT} = 2.6\text{ V}$ to 7.8 V ; $R_L = 6.2\text{ }\Omega$ SLOPECRx = 00 | 0.32 | 0.61 | 0.89 | V/ μs |
| | | $V_{OUT} = 2.6\text{ V}$ to 7.8 V ; $R_L = 6.2\text{ }\Omega$ SLOPECRx = 01 | 0.38 | 0.73 | 1.11 | V/ μs |

| Symbol | Parameter | Test conditions | Min. | Typ. | Max. | Unit |
|-----------------------------|---|--|------|------|---------------------|------------|
| $(dV_{OUT}/dt)_{on}^{(1)}$ | Turn-on voltage slope Ch0-5 at $T_J = 25\text{ °C}$ to 150 °C | $V_{OUT} = 2.6\text{ V}$ to 7.8 V ; $R_L = 6.2\ \Omega$ SLOPECRx = 10 | 0.44 | 0.87 | 1.31 | V/ μ s |
| | | $V_{OUT} = 2.6\text{ V}$ to 7.8 V ; $R_L = 6.2\ \Omega$ SLOPECRx = 11 | 0.5 | 1 | 1.51 | V/ μ s |
| $(dV_{OUT}/dt)_{off}^{(1)}$ | Turn-off voltage slope Ch0-5 at $T_J = 25\text{ °C}$ to 150 °C | $V_{OUT} = 10.4\text{ V}$ to 5.2 V ; $R_L = 6.2\ \Omega$ SLOPECRx = 00 | 0.28 | 0.54 | 0.82 | V/ μ s |
| | | $V_{OUT} = 10.4\text{ V}$ to 5.2 V ; $R_L = 6.2\ \Omega$ SLOPECRx = 01 | 0.42 | 0.93 | 1.13 | V/ μ s |
| | | $V_{OUT} = 10.4\text{ V}$ to 5.2 V ; $R_L = 6.2\ \Omega$ SLOPECRx = 10 | 0.42 | 0.93 | 1.44 | V/ μ s |
| | | $V_{OUT} = 10.4\text{ V}$ to 5.2 V ; $R_L = 6.2\ \Omega$ SLOPECRx = 11 | 0.5 | 1.13 | 1.75 | V/ μ s |
| W_{ON} | Switching losses energy at turn-on | $R_L = 6.2\ \Omega$; SLOPECRx = 00 | | 0.15 | 0.30 ⁽²⁾ | mJ |
| W_{OFF} | Switching losses energy at turn-off | $R_L = 6.2\ \Omega$; SLOPECRx = 00 | | 0.14 | 0.20 ⁽²⁾ | mJ |

1. see Figure 32. Switching characteristics

2. Parameter specified by design and evaluated by characterization, not tested in production.

Table 56. BULB - protection and diagnostics ($7 < V_{CC} < 19\text{ V}$)

| Symbol | Parameter | Test conditions | Min. | Typ. | Max. | Unit |
|---------------------|-------------------------------|--|---------------|-----------------|---------------|------|
| $I_{limH}^{(1)}$ | DC short-circuit current | $V_{CC} = 16\text{ V}$, $T_J = -40\text{ °C}$ | -15% | 36 | 15% | A |
| | | $V_{CC} = 16\text{ V}$, $T_J = 150\text{ °C}$ | -15% | 26.5 | 15% | |
| $I_{limH2}^{(2)}$ | | $V_{CC} = 19\text{ V}$, $T_J = -40\text{ °C}$ | -15% | 27.5 | 15% | |
| | | $V_{CC} = 19\text{ V}$, $T_J = 150\text{ °C}$ | -15% | 21 | 15% | |
| I_{limH2} at 22 V | | $V_{CC} = 22\text{ V}$, $T_J = 25\text{ °C}$ | | 40% I_{limH2} | | |
| V_{DEMAG} | Turn-off output voltage clamp | $I_{OUT} = 0.8\text{ A}$; $V_{IN} = 0\text{ V}$; $L = 6\text{ mH}$; $25\text{ °C} < T_J < 150\text{ °C}$ | $V_{CC} - 36$ | $V_{CC} - 38$ | $V_{CC} - 45$ | V |

1. I_{LIMH} , guaranteed between 7 V and 16 V, $-40\text{ °C} < T_J < 150\text{ °C}$.

2. I_{LIMH2} , guaranteed between 16 V and 19 V, $-40\text{ °C} < T_J < 150\text{ °C}$.

Table 57. BULB - Digital current sense ($7\text{ V} < V_{CC} < 18\text{ V}$, $T_J = -40\text{ °C}$ to 150 °C)

| Symbol | Parameter | Test conditions | Min. | Typ. | Max. | Unit |
|-------------------------------------|--|---------------------------|------|------|------|---------|
| K_{OL} | Digital current sense gain: ADC_{OUT} / I_{OUT} | $I_{OUT} = 25\text{ mA}$ | -65% | 103 | 65% | |
| K_{LED} | Digital current sense gain: ADC_{OUT} / I_{OUT} | $I_{OUT} = 50\text{ mA}$ | -35% | 103 | 35% | |
| K_0 | Digital current sense gain: ADC_{OUT} / I_{OUT} | $I_{OUT} = 420\text{ mA}$ | -15% | 107 | 15% | |
| K_1 | Digital current sense gain: ADC_{OUT} / I_{OUT} | $I_{OUT} = 2.1\text{ A}$ | -8% | 107 | 8% | |
| K_2 | Digital current sense gain: ADC_{OUT} / I_{OUT} | $I_{OUT} = 6.3\text{ A}$ | -7% | 107 | 7% | |
| $I_{OUT_OFFSET}^{(1)}$ | Output current offset | ISENSE = 000H | -45 | | 45 | mA |
| $I_{OUT_SAT_BULB}$ | Output saturation current in BULB mode | ISENSE = 3FFH | 8.5 | | | A |
| $t_{ON_CS}^{(min)}$ ⁽¹⁾ | Minimum ON time for digital current sense availability | | | | 280 | μ s |

1. Parameter specified by design and evaluated by characterization, not tested in production.

7.7 LED mode

7 V < V_{CC} < 18 V; -40 °C < T_J < 150 °C, unless otherwise specified.

Table 58. LED - power section

| Symbol | Parameter | Test conditions | Min. | Typ. | Max. | Unit |
|--------------------------------|---------------------|---|------|------|------|------|
| R _{ON} ⁽¹⁾ | ON-state resistance | I _{OUT} = 0.525 A; T _J = 25 °C | - | 120 | | mΩ |
| | | I _{OUT} = 0.525 A; T _J = 150 °C | - | | 270 | mΩ |
| | | I _{OUT} = 0.525 A; V _{CC} = 4 V; T _J = 25 °C | - | | 210 | mΩ |
| | | I _{OUT} = 0.262 A; V _{CC} = 2.9 V; V _{CC} decreasing | - | | 1200 | mΩ |

1. For each channel.

Table 59. LED - switching (V_{CC} = 13 V; Normal switch mode)

| Symbol | Parameter | Test conditions | Min. | Typ. | Max. | Unit |
|---|--|--|------|------|---------------------|------|
| t _{don} ⁽¹⁾ | Turn-on delay time Ch0-5 at T _J = 25 °C to 150 °C | Fail-safe mode, LED mode, from DIx rising to 20% V _{OUT} ; R _L = 25 Ω, SLOPECRx = 00 | 8 | 14 | 20 | μs |
| t _{doff} ⁽¹⁾ | Turn-off delay time Ch0-5 at T _J = 25 °C to 150 °C | Fail-safe mode, LED mode, from DIx falling to 80 % V _{OUT} ; R _L = 25 Ω, SLOPECRx = 00 | 11 | 18 | 25 | μs |
| t _{skew} ⁽¹⁾ | Turn-off, turn-on time Ch0-5 at T _J = 25 °C to 150 °C | Differential pulse skew (t _{pHL} - t _{pLH}), R _L = 25 Ω, SLOPECRx = 00 | -47 | 3 | 53 | V/μs |
| (dV _{OUT} /dt) _{on} ⁽¹⁾ | Turn-on voltage slope Ch0-5 at T _J = 25 °C to 150 °C | V _{OUT} = 2.6 V to 7.8 V, R _L = 25 Ω, SLOPECRx = 00 | 0.74 | 1.26 | 1.78 | V/μs |
| | | V _{OUT} = 2.6 V to 7.8 V, R _L = 25 Ω, SLOPECRx = 01 | 0.93 | 1.51 | 2.08 | V/μs |
| | | V _{OUT} = 2.6 V to 7.8 V, R _L = 25 Ω, SLOPECRx = 10 | 1.15 | 1.76 | 2.38 | V/μs |
| | | V _{OUT} = 2.6 V to 7.8 V, R _L = 25 Ω, SLOPECRx = 11 | 1.41 | 2.05 | 2.69 | V/μs |
| (dV _{OUT} /dt) _{off} ⁽¹⁾ | Turn-off voltage slope Ch0-5 at T _J = 25 °C to 150 °C | V _{OUT} = 10.4 V to 5.2 V, R _L = 25 Ω, SLOPECRx = 00 | 0.21 | 0.87 | 1.53 | V/μs |
| | | V _{OUT} = 10.4 V to 5.2 V, R _L = 25 Ω, SLOPECRx = 01 | 0.38 | 1.2 | 2.02 | V/μs |
| | | V _{OUT} = 10.4 V to 5.2 V, R _L = 25 Ω, SLOPECRx = 10 | 0.55 | 1.53 | 2.51 | V/μs |
| | | V _{OUT} = 10.4 V to 5.2 V, R _L = 25 Ω, SLOPECRx = 11 | 0.74 | 1.87 | 3 | V/μs |
| W _{ON} | Switching losses energy at turn-on | R _L = 25 Ω, SLOPECRx = 00 | | 0.02 | 0.04 ⁽²⁾ | mJ |
| W _{OFF} | Switching losses energy at turn-off | R _L = 25 Ω, SLOPECRx = 00 | | 0.02 | 0.04 ⁽²⁾ | mJ |

1. See Figure 32. Switching characteristics

2. Parameter specified by design and evaluated by characterization, not tested in production.

Table 60. LED - protection and diagnosis

| Symbol | Parameter | Test conditions | Min. | Typ. | Max. | Unit |
|--------------------|--------------------------|---|------|------|-----------------|------|
| $I_{limH}^{(1)}$ | DC short-circuit current | $V_{CC} = 16\text{ V}, T_J = -40\text{ }^\circ\text{C}$ | -15% | 9.7 | 15% | A |
| | | $V_{CC} = 16\text{ V}, T_J = 150\text{ }^\circ\text{C}$ | -15% | 7.4 | 15% | |
| $I_{limH2}^{(2)}$ | | $V_{CC} = 19\text{ V}, T_J = -40\text{ }^\circ\text{C}$ | -15% | 7.8 | 15% | A |
| | | $V_{CC} = 19\text{ V}, T_J = 150\text{ }^\circ\text{C}$ | -15% | 5.9 | 15% | |
| I_{limH2} at 22V | | $V_{CC} = 22\text{ V}, T_J = 25\text{ }^\circ\text{C}$ | | | 40% I_{limH2} | A |

1. I_{limH} , guaranteed between 7 V and 16 V, $-40\text{ }^\circ\text{C} < T_J < 150\text{ }^\circ\text{C}$.

2. I_{limH2} , guaranteed between 16 V and 19 V, $-40\text{ }^\circ\text{C} < T_J < 150\text{ }^\circ\text{C}$.

Table 61. LED - Digital Current Sense ($7\text{ V} < V_{CC} < 18\text{ V}, T_J = -40\text{ }^\circ\text{C}$ to $150\text{ }^\circ\text{C}$)

| Symbol | Parameter | Test conditions | Min. | Typ. | Max. | Unit |
|-------------------------|--|----------------------------|------|------|------|---------------|
| K_{OL} | Digital current sense gain: ADC_{OUT} / I_{OUT} | $I_{OUT} = 25\text{ mA}$ | -65 | 400 | 65 | % |
| K_{LED} | Digital current sense gain: ADC_{OUT} / I_{OUT} | $I_{OUT} = 40\text{ mA}$ | -35 | 400 | 35 | % |
| K_0 | Digital current sense gain: ADC_{OUT} / I_{OUT} | $I_{OUT} = 105\text{ mA}$ | -15 | 409 | 15 | % |
| K_1 | Digital current sense gain: ADC_{OUT} / I_{OUT} | $I_{OUT} = 525\text{ mA}$ | -8 | 409 | 8 | % |
| K_2 | Digital current sense gain: ADC_{OUT} / I_{OUT} | $I_{OUT} = 1.575\text{ A}$ | -7 | 409 | 7 | % |
| $I_{OUT_OFFSET}^{(1)}$ | Output current offset | $ISENSE = 000H$ | -15 | | 15 | mA |
| $I_{OUT_SAT_LED}$ | Output saturation current in LED mode | $ISENSE = 3FFH$ | 2.3 | | | A |
| $t_{ON_CS(min)_LED}$ | Minimum ON time for digital current sense availability | | | | 150 | μs |

1. All values refer to $V_{CC} = 13\text{ V}; T_J = 25\text{ }^\circ\text{C}$, unless otherwise specified.

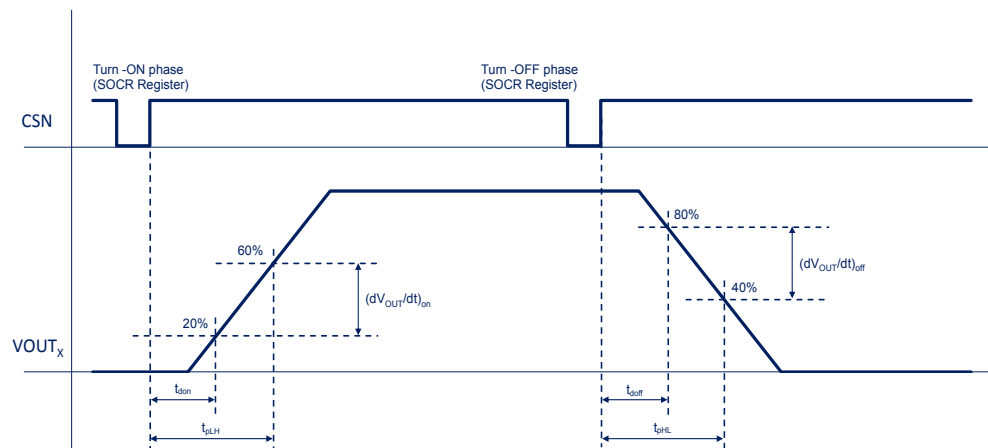
Figure 32. Switching characteristics

7.8 Waveforms

Figure 33. Normal mode - Short circuit – $PBW < t_{D_Restart}$

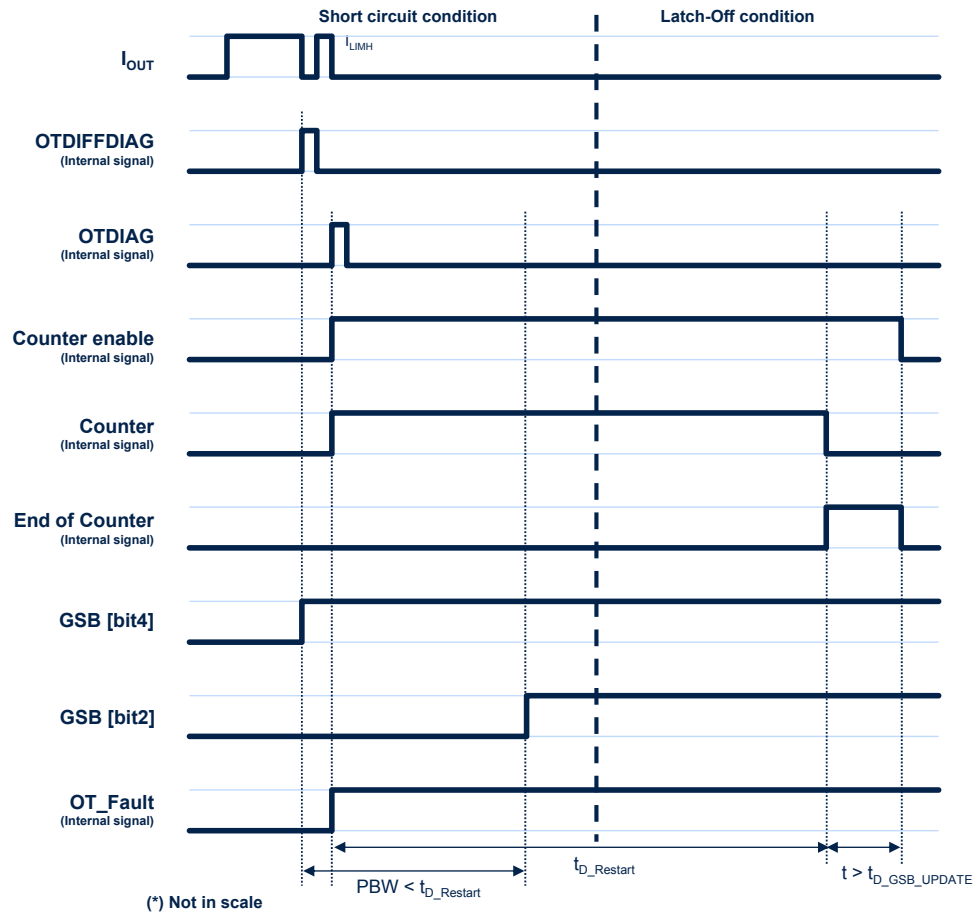
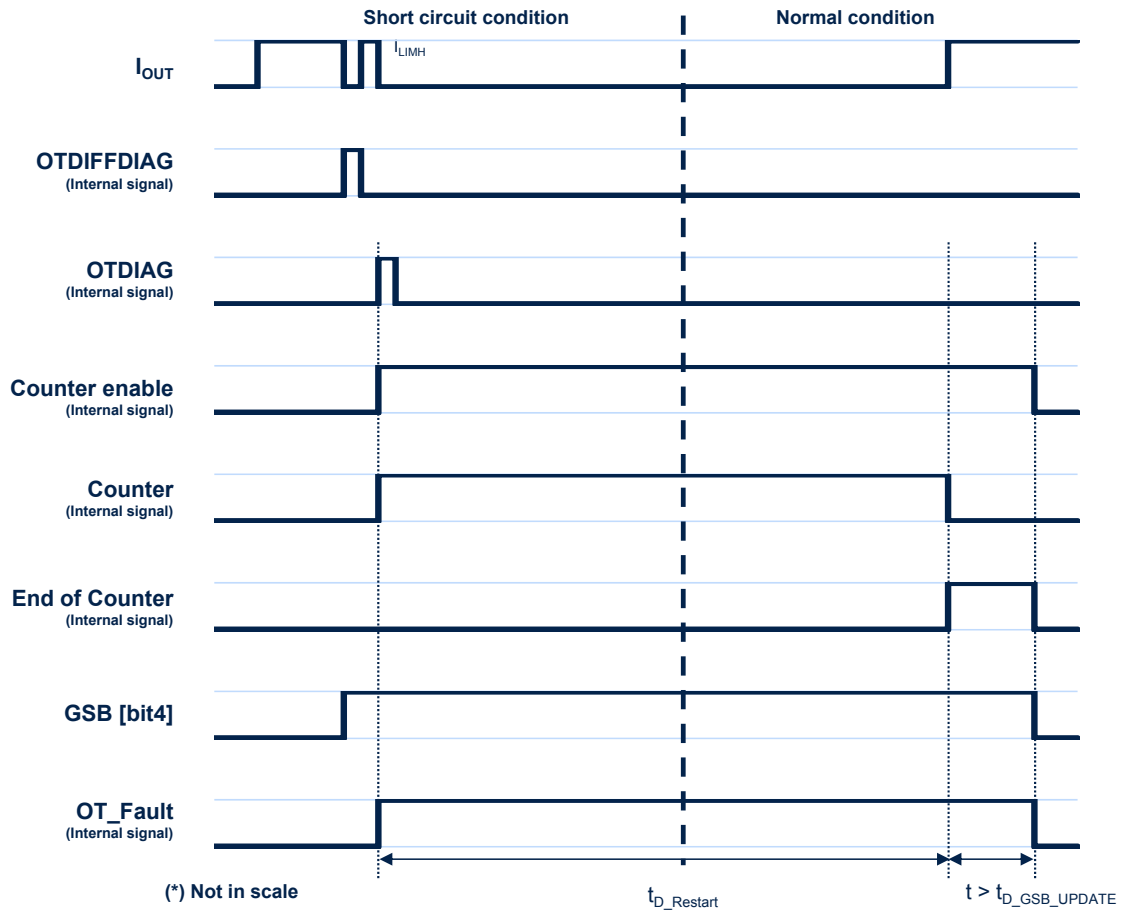

Figure 34. Normal mode - Short circuit – $PBW > t_{D_Restart}$



8 ISO Pulse

The immunity of the device against transient electrical emissions, conducted along the supply lines and injected into the VCC pin, is tested in accordance with ISO7637-2:2011(E) and ISO 16750-2:2010.

The related function performances status classification is shown in the [Table 62. ISO 7637-2 - electrical transient conduction along supply line](#).

Test pulses are applied directly to DUT (Device Under Test) both in ON and OFF-state and in accordance to ISO 7637-2:2011(E), chapter 4. The DUT is intended as the present device only with the typical external components as shown in [Figure 35. M0-9 SPI application schematic](#).

"Status II" is defined in ISO 7637-1 Function Performed Status Classification (FPSC) as follows: "The function does not perform as designed during the test but returns automatically to normal operation after the test".

Table 62. ISO 7637-2 - electrical transient conduction along supply line

| Test pulse 2011(E) | Test pulse severity level with status II functional performance status | | Minimum number of pulses or test time | Burst cycle / pulse repetition time | | Pulse duration and pulse generator internal impedance |
|--|--|----------------------|---------------------------------------|-------------------------------------|--------|---|
| | Level | U_S ⁽¹⁾ | | | | |
| 1 | III | -112 V | 500 pulses | 0.5 s | 5 s | 2 ms, 10 Ω |
| 2a ⁽²⁾ | III | +55 V | 500 pulses | 0.2 s | 5 s | 50 μ s, 2 Ω |
| 3a | IV | -220 V | 1 h | 90 ms | 100 ms | 0.1 μ s, 50 Ω |
| 3b | IV | +150 V | 1 h | 90 ms | 100 ms | 0.1 μ s, 50 Ω |
| 4 ⁽³⁾ | IV | -7 V | 1 pulse | | | 100 ms, 0.01 Ω |
| Load dump according to ISO 16750-2:2010 | | | | | | |
| Test B ⁽²⁾ | | +87 V | 5 pulse | 1 min | | 400 ms, 2 Ω |

- U_S is the peak amplitude as defined for each test pulse in ISO 7637-2:2011(E), chapter 5.6.
- With 35 V external suppressor referred to ground ($-40\text{ }^\circ\text{C} < T_J < 150\text{ }^\circ\text{C}$).
- Test pulse in ISO 7637-2:2004(E).

9 Application schematics

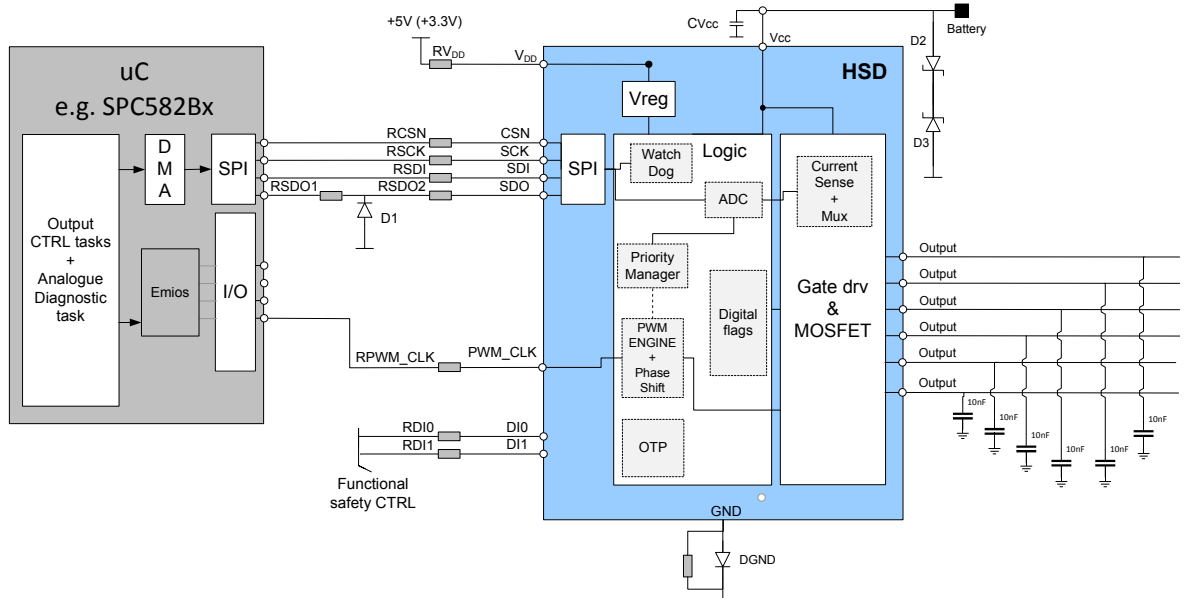
Figure 35. M0-9 SPI application schematic

Table 63. Component values

| Reference | Value | comment |
|------------------|---|---|
| RV _{DD} | 330 Ω | Device logic protection |
| CV _{CC} | 100 nF | Battery voltage spikes filtering mounted close to IC |
| RCSN | 2.7 kΩ | Microcontroller protection during overvoltage and reverse polarity |
| RSCK | 2.7 kΩ | Microcontroller protection during overvoltage and reverse polarity |
| RSDI | 2.7 kΩ | Microcontroller protection during overvoltage and reverse polarity |
| RSDO2 | 220 Ω | Microcontroller protection during overvoltage and reverse polarity |
| RSDO1 | 50 Ω | Optional |
| D1 | BAT54 | Microcontroller protection during overvoltage and reverse polarity |
| RPWM_CLK | 2.2 kΩ | Microcontroller protection during: overvoltage, reverse polarity and loss of GND |
| RDI0 | 15 kΩ | Microcontroller protection during: overvoltage, reverse polarity and loss of GND |
| RDI1 | 15 kΩ | Microcontroller protection during: overvoltage, reverse polarity and loss of GND |
| D2 | Suppressor 20 V | Negative transient protection. |
| D3 | Suppressor 36 V | Overvoltage protection. |
| RGND | 4.7 kΩ | |
| DGND | BAS21 for V _{DD} = 5 V Schottky (i.e., BAT54-Y) for V _{DD} = 3.3 V | Reverse polarity protection. Usage of schottky or standard diode dependent on V _{DD} |

10 Maximum demagnetization energy ($V_{CC} = 16\text{ V}$)

Figure 36. Maximum turn-off current versus inductance - Bulb mode all channels

Figure 37. Maximum turn-off energy versus inductance - Bulb mode all channels

Figure 38. Maximum turn-off current versus inductance - LED mode all channels

Figure 39. Maximum turn-off energy versus inductance - LED mode all channels

Note: Values are generated with $R_L = 0\ \Omega$.

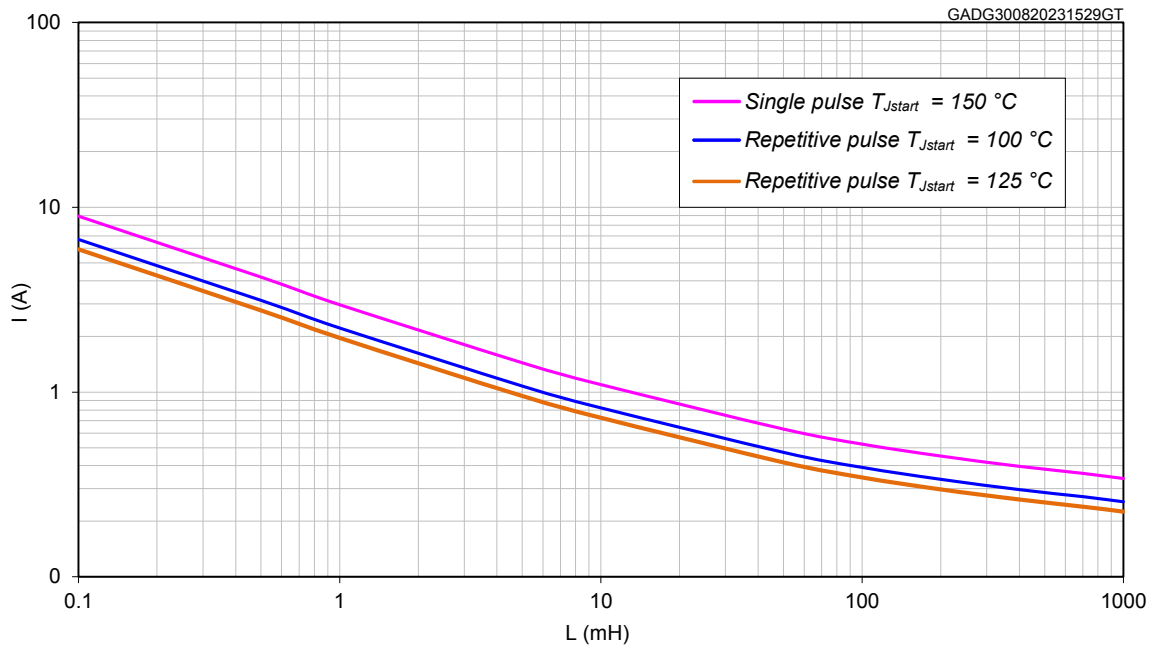
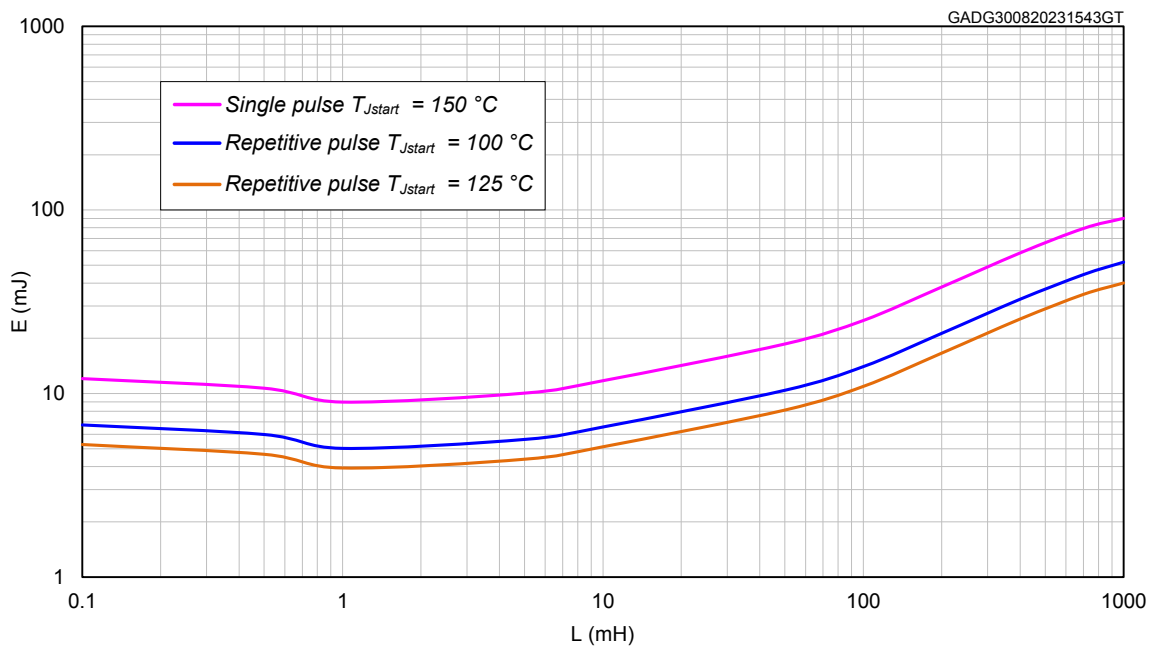
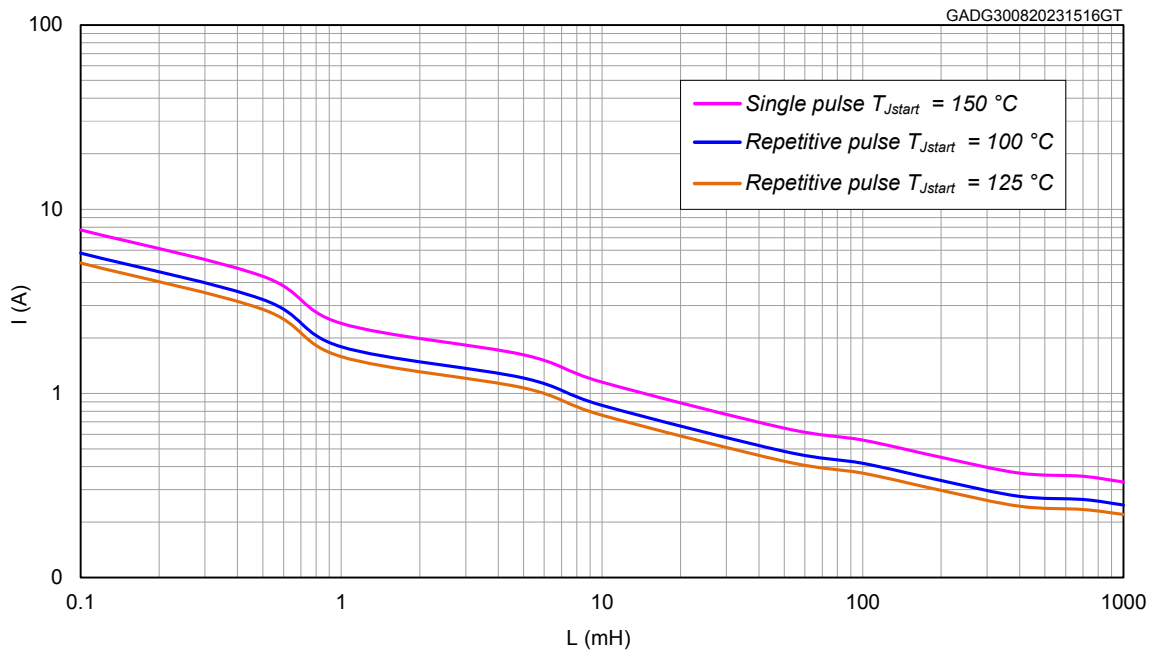
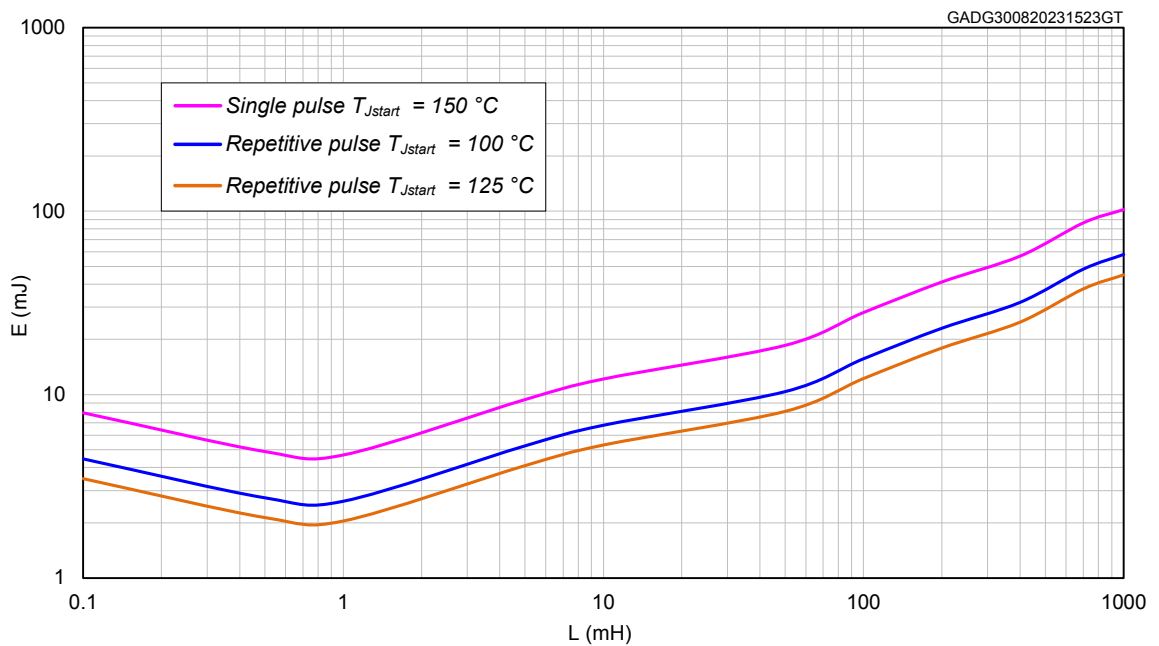
In the case of repetitive pulses, T_{Jstart} (at the beginning of each demagnetization) of every pulse must not exceed the temperature specified above for repetitive curves.

11 Package and PCB thermal data

11.1 QFN 6x6 thermal data

Figure 40. QFN 6x6 PCB footprint

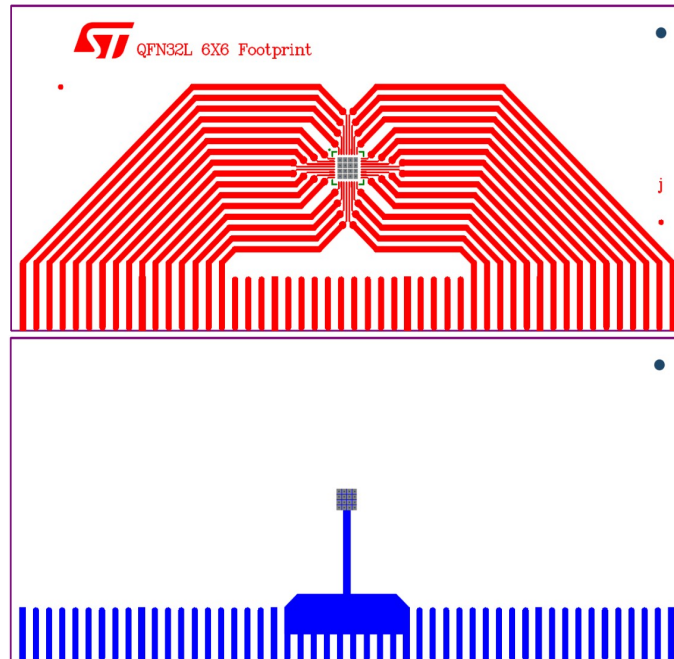

Figure 41. QFN 6x6 PCB 2 cm²

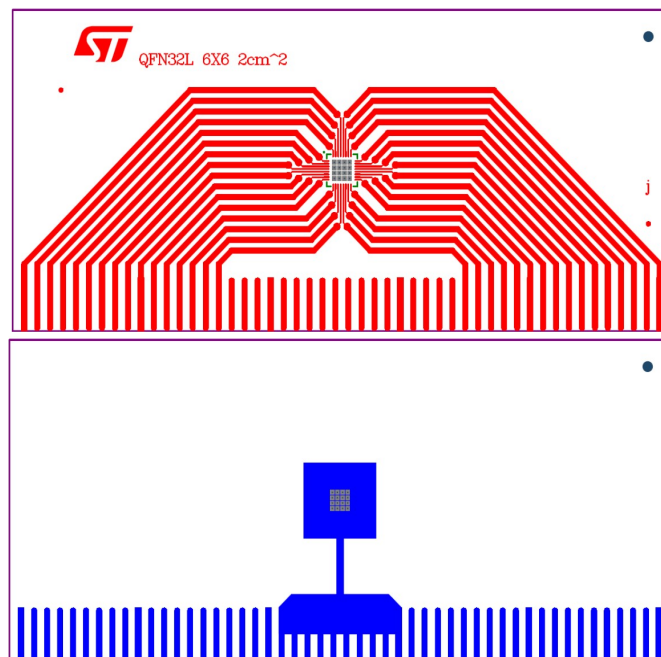

Figure 42. QFN 6x6 PCB 8 cm²

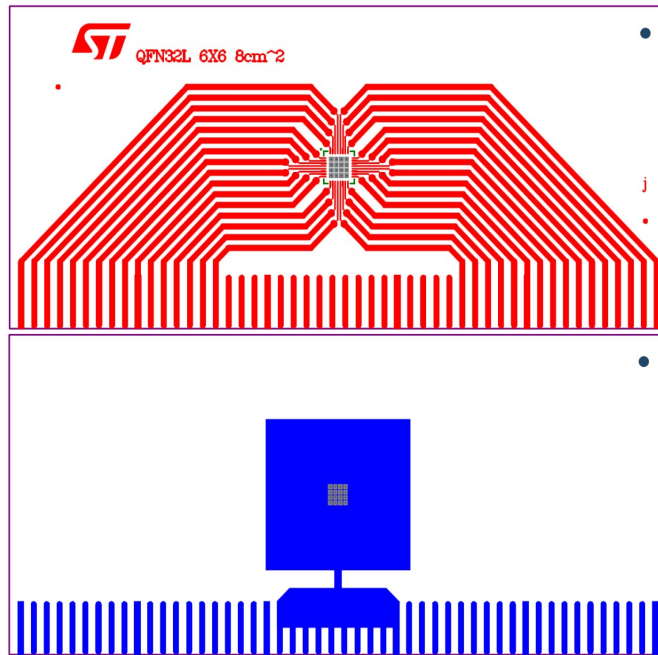

Figure 43. QFN 6x6 PCB 4 layers

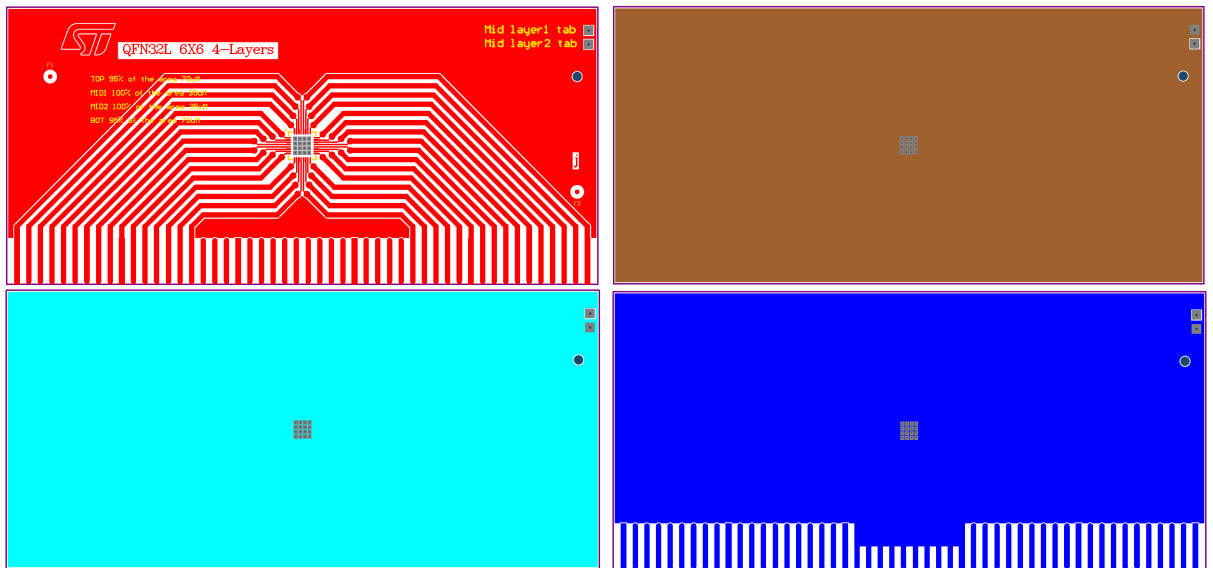
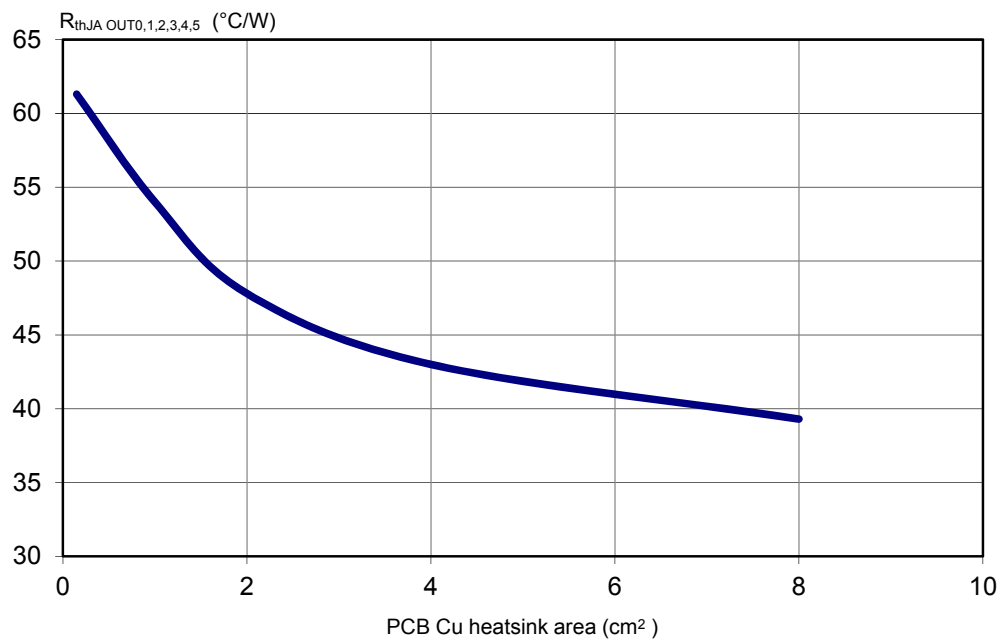

Table 64. PCB properties

| Dimension | Value |
|---|---|
| Board finish thickness | 1.6 mm ±10% |
| Board dimension | 129 mm x 60 mm |
| Board material | FR4 |
| Cu thickness (top and bottom layers) | 0.070 mm |
| Cu thickness (inner layers) | 0.035 mm |
| Thermal vias separation | 1.2 mm |
| Thermal vias diameter | 0.3 mm ±0.08 mm |
| Cu thickness on vias | 0.025 mm |
| Footprint dimension (top layer) | 3.8 mm x 3.8 mm |
| Heatsink copper area dimension (bottom layer) | Footprint, 2 cm ² or 8 cm ² |

Figure 44. R_{thJA} vs PCB copper area in open box free air conditions



R_{thJA} on 4Layers PCB: 24.5 °C/W

Figure 45. QFN 6x6 thermal impedance junction ambient

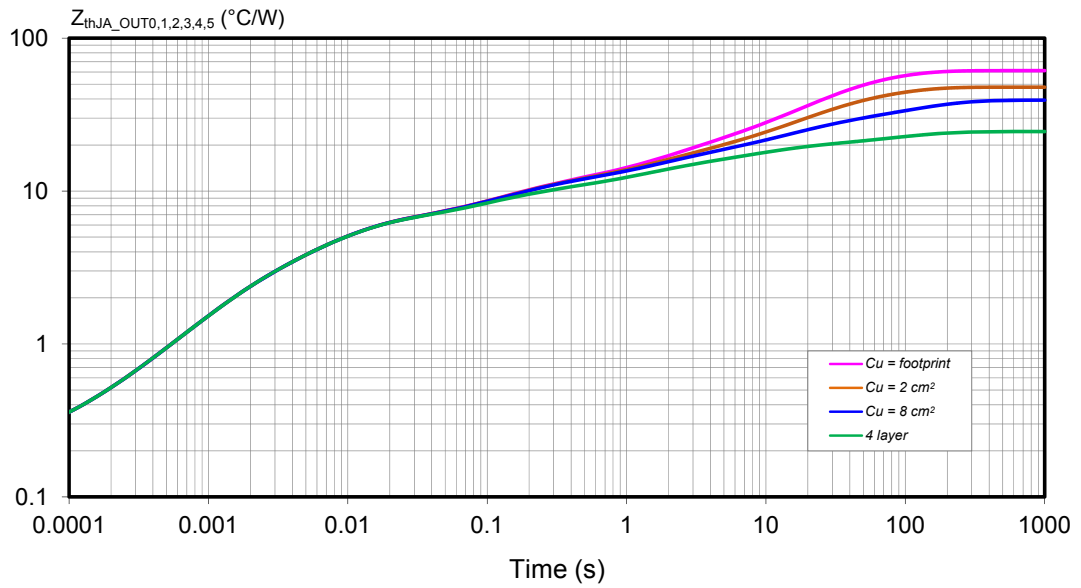

$$Z_{th\delta} = R_{th} \cdot \delta + Z_{thtp} (1 - \delta); \text{ where } \delta = t_p/T$$

Figure 46. Thermal fitting model

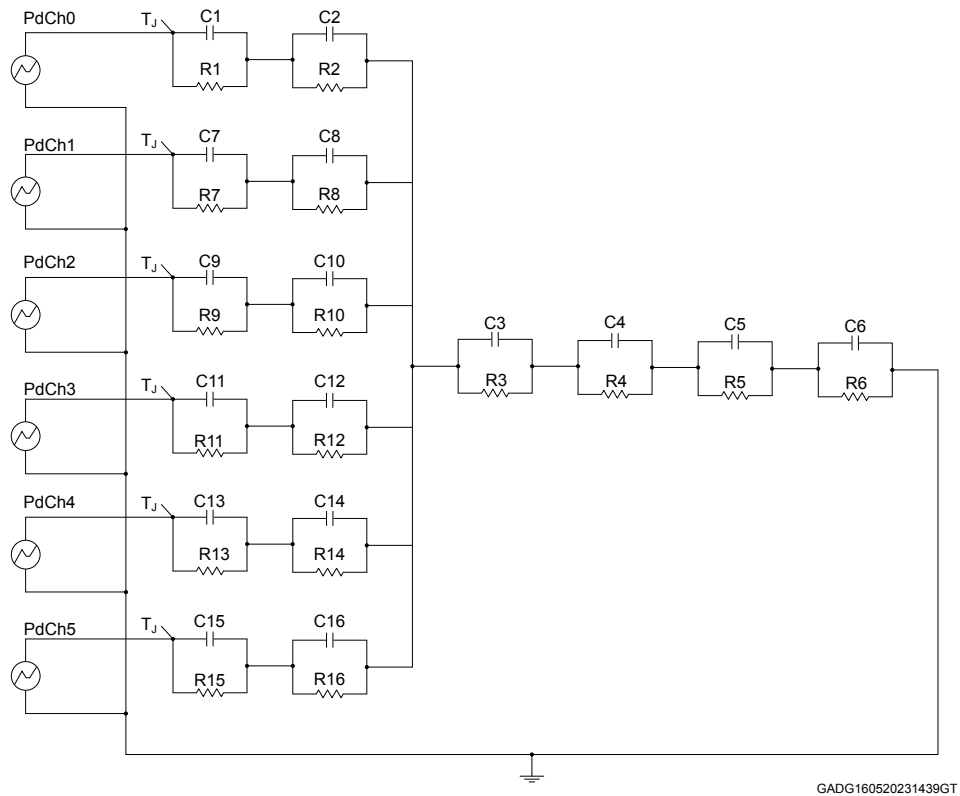

Note: The fitting model is a simplified thermal tool and is valid for transient evolutions where the embedded protections (power limitation or thermal cycling during thermal shutdown) are not triggered.

Table 65. Thermal parameters

| Area/island (cm ²) | FP | 2 | 8 | 4L |
|--|--------|------|-----|-----|
| R1 = R7 = R9 = R11 = R13 = R15 (°C/W) | 1.4 | | | |
| R2 = R8 = R10 = R12 = R14 = R16 (°C/W) | 4.4 | | | |
| R3 (°C/W) | 4.5 | 4.5 | 4.5 | 3.5 |
| R4 (°C/W) | 6 | 5 | 5 | 4 |
| R5 (°C/W) | 21 | 15 | 10 | 5.5 |
| R6 (°C/W) | 24 | 17.5 | 14 | 5.7 |
| C1 = C7 = C9 = C11 = C13 = C15 (W·s/°C) | 0.0008 | | | |
| C2 = C8 = C10 = C12 = C14 = C16 (W·s/°C) | 0.0016 | | | |
| C3 (W·s/°C) | 0.03 | | | |
| C4 (W·s/°C) | 0.3 | | | |
| C5 (W·s/°C) | 1 | 1.2 | 1.4 | 1.4 |
| C6 (W·s/°C) | 2.4 | 3.5 | 8 | 15 |

12 Package information

In order to meet environmental requirements, ST offers these devices in different grades of **ECOPACK** packages, depending on their level of environmental compliance. ECOPACK specifications, grade definitions and product status are available at: www.st.com. ECOPACK is an ST trademark.

12.1 QFN 6x6 package information

Figure 47. QFN 6x6 package outline

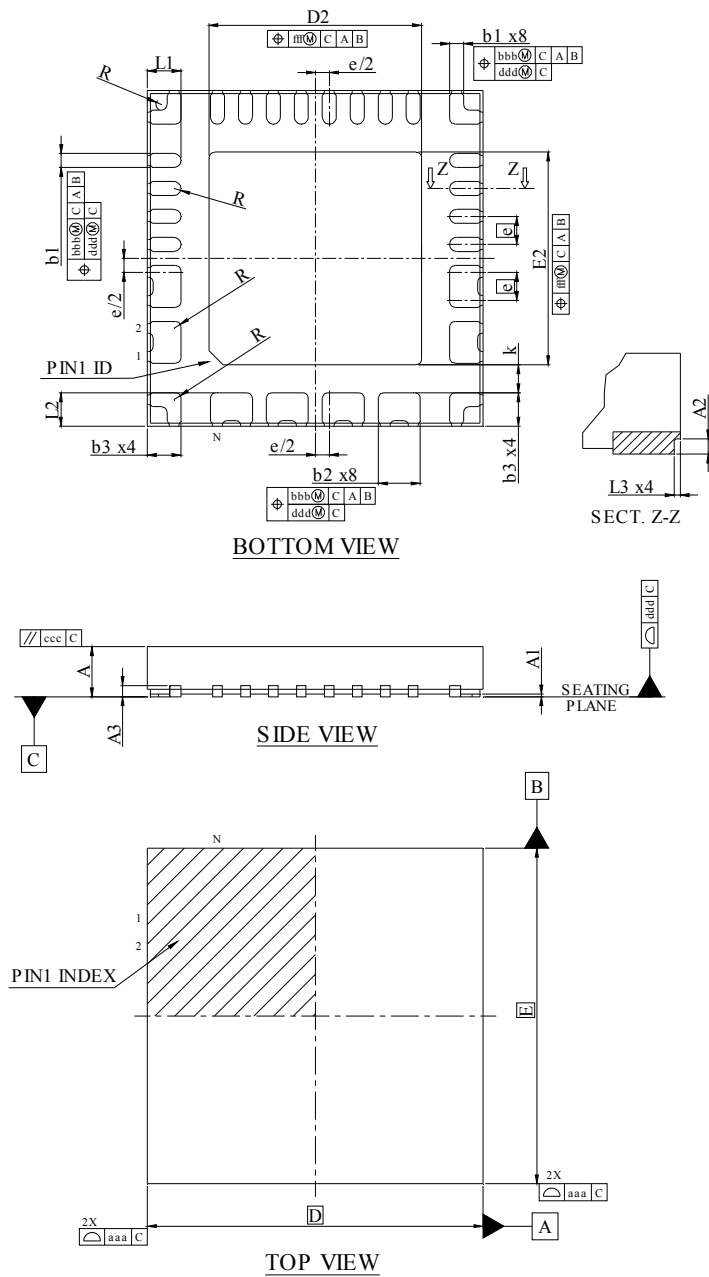

DM00346180_2

Table 66. QFN 6x6 mechanical data

| Dim. | Millimeters | | |
|------|-------------|------|------|
| | Min. | Typ. | Max. |
| A | 0.80 | 0.90 | 1.00 |
| A1 | 0.00 | - | 0.05 |
| A2 | 0.10 | | |
| A3 | 0.20 REF. | | |
| b1 | 0.20 | 0.25 | 0.30 |
| b2 | 0.70 | 0.75 | 0.80 |
| b3 | 0.50 | 0.60 | 0.70 |
| D | 6.00 BSC | | |
| E | 6.00 BSC | | |
| e | 0.50 BSC | | |
| L1 | 0.50 | 0.60 | 0.70 |
| L2 | 0.50 | 0.60 | 0.70 |
| L3 | | | 0.05 |
| k | 0.45 | | |
| R | | | 0.10 |
| N | 32+4 | | |

Table 67. QFN 6x6 tolerance of form and position

| Dim. | Millimeters |
|------|-------------|
| aaa | 0.15 |
| bbb | 0.10 |
| ccc | 0.10 |
| ddd | 0.05 |
| eee | 0.08 |
| fff | 0.10 |

Table 68. QFN 6x6 variations

| Dim. | Millimeters | | | OPT. |
|------|-------------|------|------|------|
| | Min. | Typ. | Max. | |
| D2 | 3.70 | 3.80 | 3.90 | A |
| E2 | 3.70 | 3.80 | 3.90 | |

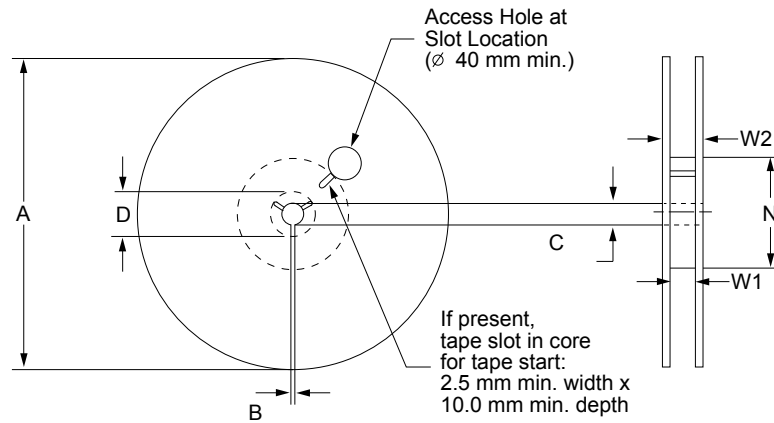
12.2 QFN 6x6 packing information
Figure 48. QFN 6x6 reel 13"

TAPG2004151655CFT

Table 69. Reel dimensions

| Description | Value ⁽¹⁾ |
|----------------|----------------------|
| Base quantity | 3000 |
| Bulk quantity | 3000 |
| A (max) | 330 |
| B (min) | 1.5 |
| C (+0.5, -0.2) | 13 |
| D (min) | 20.2 |
| N | 178 |
| W1 | 146.4 |
| W2 | 22.4 |

1. All dimensions are in mm.

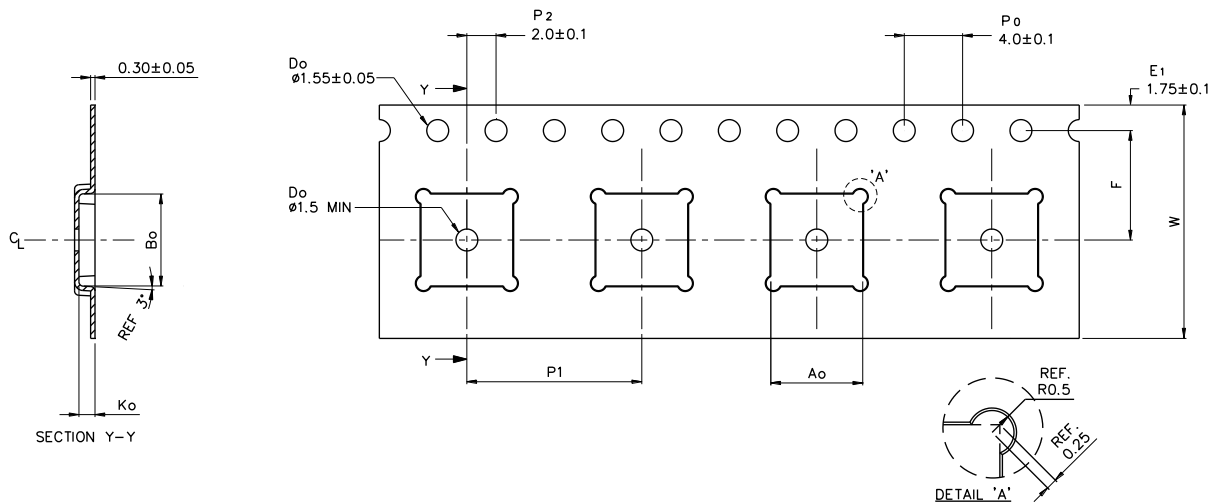
Figure 49. QFN 6x6 carrier tape

GADG140420211629GT

Table 70. QFN 6x6 carrier tape dimensions

| Description | Value ⁽¹⁾ |
|----------------|----------------------|
| A ₀ | 6.30 ± 0.1 |
| B ₀ | 6.30 ± 0.1 |
| K ₀ | 1.10 ± 0.1 |
| F | 7.50 ± 0.1 |
| P ₁ | 12.00 ± 0.1 |
| W | 16.00 ± 0.3 |

1. All dimensions are in mm.

12.3 QFN 6x6 marking information

Figure 50. QFN 6x6 marking information

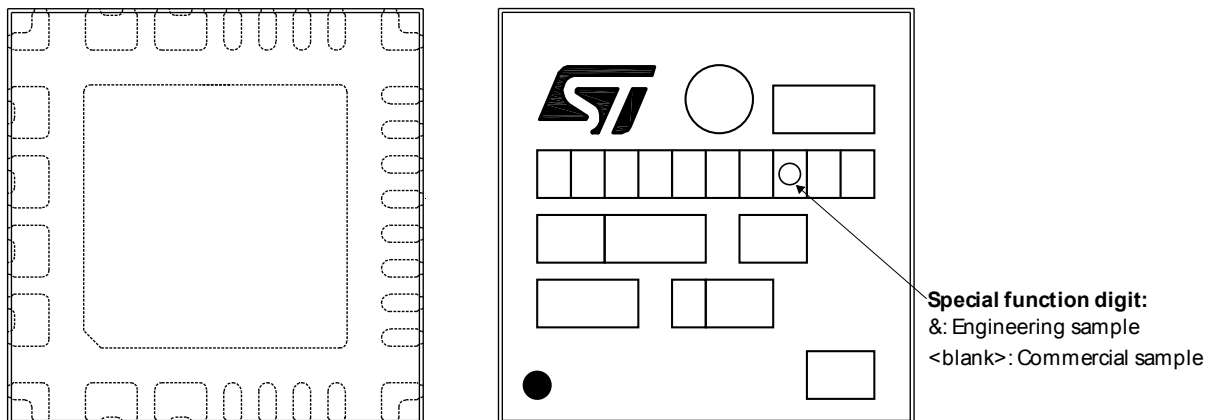

Parts marked as '&' are not yet qualified and therefore not approved for use in production. ST is not responsible for any consequences resulting from such use. In no event will ST be liable for the customer using any of these engineering samples in production. ST's Quality department must be contacted prior to any decision to use these engineering samples to run a qualification activity.

Revision history

Table 71. Document revision history

| Date | Revision | Changes |
|-------------|----------|--|
| 18-Nov-2019 | 1 | Initial release |
| 01-Sep-2023 | 2 | <p>Updated <i>Features and Device summary</i> on cover page.</p> <p>Updated <i>Table 2, Figure 3, Section 2.2.2 Reset mode and Section 2.2.3 Fail-safe mode.</i></p> <p>Updated <i>Section 3.2 Junction overtemperature (OT) and Section 3.3 Power limitation (PL).</i></p> <p>Updated <i>Section 4.3.2 RAM, Section 4.3.3 ROM, Section 4.4 Outputs control, Section 4.4.1 Procedure to turn on the outputs in PWM operations, Table 32, Table 33 and Section 6.5 Registers.</i></p> <p>Updated <i>Figure 18, Section 5.1.2 ADC operating principle, Section 5.4 Overload (VDS high voltage, Overload (OVL)), Section 5.6 Open-load OFF-state detection and Section 5.9 Openload in OFF-State / Stuck to VCC Status bit "STKFLTR" in OUTSRx register and removed Figure 24. Diagnostics registers.</i></p> <p>Updated <i>Table 43 and Section 6.5 Registers.</i></p> <p>Update <i>Section 7.1 Absolute maximum ratings, Section 7.2 Thermal data, Table 46, Table 48, Table 49, Table 51, Table 52, Section 7.5 PWM unit, Section 7.6 BULB mode and Section 7.7 LED mode.</i></p> <p>Added <i>Section 9 Application schematics, Section 10 Maximum demagnetization energy (VCC = 16 V) and Section 11 Package and PCB thermal data.</i></p> <p>Minor text changes.</p> |
| 19-Jun-2024 | 3 | <p>Updated <i>Figure 2. Connection diagram (top view), Table 1, Section 3.2: Junction overtemperature (OT), Table 49. Power section, CHLOFFTCR1, Section 4.4: Outputs control, Section 5.1.4.3: Asynchronous mode and Table 62. ISO 7637-2 - electrical transient conduction along supply line.</i></p> <p>Added <i>Section 7.8: Waveforms, Section 12.2: QFN 6x6 packing information and Section 12.3: QFN 6x6 marking information.</i></p> |

Contents

| | | |
|----------|--|-----------|
| 1 | Block diagram and pin description | 3 |
| 2 | Functional description | 5 |
| 2.1 | Device interfaces | 5 |
| 2.2 | Operating modes | 6 |
| 2.2.1 | Startup transition phase | 9 |
| 2.2.2 | Reset mode | 9 |
| 2.2.3 | Fail-safe mode | 9 |
| 2.2.4 | Normal mode | 11 |
| 2.2.5 | Standby mode | 12 |
| 2.2.6 | Sleep mode 1 | 14 |
| 2.2.7 | Sleep mode 2 | 14 |
| 2.2.8 | Battery undervoltage mode | 14 |
| 2.2.9 | Limp-home mode | 16 |
| 3 | Protections | 17 |
| 3.1 | Pre-warning | 17 |
| 3.2 | Junction overtemperature (OT) | 17 |
| 3.3 | Power limitation (PL) | 18 |
| 4 | SPI functional description | 19 |
| 4.1 | SPI communication | 19 |
| 4.1.1 | Signal description | 19 |
| 4.1.2 | Connecting to the SPI bus | 19 |
| 4.1.3 | SPI mode | 20 |
| 4.2 | SPI protocol | 21 |
| 4.2.1 | SDI, SDO format | 21 |
| 4.2.2 | Operating code definition | 22 |
| 4.2.3 | Special commands | 25 |
| 4.3 | Register map | 25 |
| 4.3.1 | Global Status byte description | 25 |
| 4.3.2 | RAM | 27 |
| 4.3.3 | ROM | 28 |
| 4.3.4 | SPI modes | 28 |
| 4.4 | Outputs control | 30 |
| 4.4.1 | Procedure to turn on the outputs in PWM operations | 30 |
| 4.4.2 | OTP programming | 35 |
| 4.4.3 | Procedure to turn on the outputs with the direct input Dlx | 35 |

| | | |
|----------|--|-----------|
| 4.5 | Output switching slopes control | 36 |
| 4.6 | Control registers | 37 |
| | OUTCTRCRx | 37 |
| | OUTCFGRx | 38 |
| | CHLOFFTCR0 | 40 |
| | CHLOFFTCR1 | 41 |
| | SOCR | 42 |
| | CTRL | 43 |
| | OUTSRx | 45 |
| | ADCxSR | 46 |
| | ADC9SR | 47 |
| | OTP memory map (Reserved) | 47 |
| 5 | Diagnostics | 48 |
| 5.1 | Digital current sense diagnostics | 48 |
| 5.1.1 | ADC characteristics | 48 |
| 5.1.2 | ADC operating principle | 49 |
| 5.1.3 | Registers | 51 |
| 5.1.4 | Synchronous, asynchronous modes | 51 |
| 5.2 | Integrated LP (Progressive Average) Filter | 54 |
| 5.3 | Digital diagnostics | 54 |
| 5.3.1 | Status registers | 55 |
| 5.4 | Overload (VDS high voltage, overload (OVL)) | 56 |
| 5.5 | Open-load ON-state detection | 56 |
| 5.6 | Open-load OFF-state detection | 57 |
| 5.7 | DIENSR: direct input status bit in OUTSRx register (address from 0x20 to 0x25) | 58 |
| 5.8 | CHFBSR: Channel Feedback Status bit in OUTSRx Register | 59 |
| 5.9 | Open-load in OFF-State / Stuck to V_{CC} Status bit “STKFLTR” in OUTSRx register | 59 |
| 5.10 | Channels latch-off status bit (CHLOFFSR) in OUTSRx register | 59 |
| 5.11 | VDS feedback status bit (VDSFSR) in the OUTSRx register | 59 |
| 6 | Programmable blanking window (PBW) | 60 |
| 6.1 | Timer | 60 |
| 6.2 | Blanking window values | 61 |
| 6.3 | Power limitation counter | 62 |
| 6.4 | Limp-home mode | 62 |
| 6.5 | Registers | 63 |
| 7 | Electrical specifications | 64 |

| | | |
|-----------|---|-----------|
| 7.1 | Absolute maximum ratings | 64 |
| 7.2 | Thermal data | 65 |
| 7.3 | SPI electrical characteristics | 66 |
| 7.4 | Electrical characteristics | 69 |
| 7.5 | PWM unit | 71 |
| 7.6 | BULB mode | 71 |
| 7.7 | LED mode | 73 |
| 7.8 | Waveforms | 75 |
| 8 | ISO Pulse | 77 |
| 9 | Application schematics | 78 |
| 10 | Maximum demagnetization energy ($V_{CC} = 16\text{ V}$) | 79 |
| 11 | Package and PCB thermal data | 81 |
| 11.1 | QFN 6x6 thermal data | 81 |
| 12 | Package information | 86 |
| 12.1 | QFN 6x6 package information | 86 |
| 12.2 | QFN 6x6 packing information | 88 |
| 12.3 | QFN 6x6 marking information | 89 |
| | Revision history | 90 |

List of tables

| | | |
|------------------|--|----|
| Table 1. | Pin functionality description | 4 |
| Table 2. | Operating modes | 6 |
| Table 3. | Frame 1 (write CTRL 0x0001) | 10 |
| Table 4. | Frame 1: read (ROM) 0x3F 0x-- | 10 |
| Table 5. | Frame 1 (Write CTRL 0x4000) | 11 |
| Table 6. | Frame 2 (Write CTRL 0x0800) | 11 |
| Table 7. | Frame 1 (write CTRL 0x4000) | 12 |
| Table 8. | Frame 2 (write CTRL 0x8000) | 13 |
| Table 9. | Frame 2 (write CTRL 0x4801) | 13 |
| Table 10. | Frame 2 (write CTRL 0x8000) | 13 |
| Table 11. | SPI signal description | 19 |
| Table 12. | Command byte | 21 |
| Table 13. | Input data byte 1 | 21 |
| Table 14. | Input data byte 2 | 21 |
| Table 15. | Global status byte | 21 |
| Table 16. | Output data byte 1 | 21 |
| Table 17. | Output data byte 2 | 21 |
| Table 18. | Operating codes | 22 |
| Table 19. | 0xFF: SW_Reset | 25 |
| Table 20. | Clear all status registers (RAM access) | 25 |
| Table 21. | Global Status Byte (GSB) | 26 |
| Table 22. | Global status byte | 26 |
| Table 23. | RAM memory map | 27 |
| Table 24. | ROM memory map | 28 |
| Table 25. | SPI mode | 28 |
| Table 26. | SPI burst read | 28 |
| Table 27. | SPI data length | 29 |
| Table 28. | SPI data consistency check | 29 |
| Table 29. | Write SOCR 0x13 | 30 |
| Table 30. | Output control truth table | 30 |
| Table 31. | Phase shift configuration | 31 |
| Table 32. | OTP memory map | 35 |
| Table 33. | OTP programming | 35 |
| Table 34. | Truth table | 35 |
| Table 35. | Switching slopes | 36 |
| Table 36. | Programmable t_{blanking} values | 41 |
| Table 37. | OTP memory map (reserved) | 47 |
| Table 38. | Registers | 51 |
| Table 39. | Sampling mode configuration | 51 |
| Table 40. | ADC Configuration registers | 53 |
| Table 41. | Status registers | 55 |
| Table 42. | STKFLTR state | 57 |
| Table 43. | Time values written by MCU and their real value in timer register | 61 |
| Table 44. | Absolute maximum ratings | 64 |
| Table 45. | Thermal data | 65 |
| Table 46. | DC characteristics | 66 |
| Table 47. | AC characteristics (SDI, SCK, CSN, SDO, PWM_CLK pins) - Mode 1 | 67 |
| Table 48. | Dynamic characteristics | 67 |
| Table 49. | Power section | 69 |
| Table 50. | Logic inputs (DI0,1 pins) | 69 |
| Table 51. | Protection | 70 |
| Table 52. | Open-load detection ($7\text{ V} < V_{\text{CC}} < 18\text{ V}$) | 70 |
| Table 53. | PWM unit | 71 |

| | | |
|------------------|---|----|
| Table 54. | BULB - power section | 71 |
| Table 55. | BULB - switching ($V_{CC} = 13\text{ V}$; normal switch mode) | 71 |
| Table 56. | BULB - protection and diagnostics ($7 < V_{CC} < 19\text{ V}$) | 72 |
| Table 57. | BULB - Digital current sense ($7\text{ V} < V_{CC} < 18\text{ V}$, $T_J = -40\text{ }^\circ\text{C}$ to $150\text{ }^\circ\text{C}$) | 72 |
| Table 58. | LED - power section | 73 |
| Table 59. | LED - switching ($V_{CC} = 13\text{ V}$; Normal switch mode) | 73 |
| Table 60. | LED - protection and diagnosis | 74 |
| Table 61. | LED - Digital Current Sense ($7\text{ V} < V_{CC} < 18\text{ V}$, $T_J = -40\text{ }^\circ\text{C}$ to $150\text{ }^\circ\text{C}$) | 74 |
| Table 62. | ISO 7637-2 - electrical transient conduction along supply line | 77 |
| Table 63. | Component values | 78 |
| Table 64. | PCB properties | 83 |
| Table 65. | Thermal parameters | 85 |
| Table 66. | QFN 6x6 mechanical data | 87 |
| Table 67. | QFN 6x6 tolerance of form and position | 87 |
| Table 68. | QFN 6x6 variations | 87 |
| Table 69. | Reel dimensions | 88 |
| Table 70. | QFN 6x6 carrier tape dimensions | 89 |
| Table 71. | Document revision history | 90 |

List of figures

| | | |
|-------------------|--|----|
| Figure 1. | Block diagram | 3 |
| Figure 2. | Connection diagram (top view) | 3 |
| Figure 3. | Device state diagram | 8 |
| Figure 4. | Battery undervoltage shutdown diagram | 15 |
| Figure 5. | Undervoltage shutdown | 16 |
| Figure 6. | Supported SPI mode | 20 |
| Figure 7. | Bus master and two devices in a normal configuration | 20 |
| Figure 8. | SPI write operation | 22 |
| Figure 9. | SPI read operation | 23 |
| Figure 10. | SPI read and clear operation | 23 |
| Figure 11. | SPI read device information | 24 |
| Figure 12. | Resulting waveform 1 | 32 |
| Figure 13. | Resulting waveform 2 | 33 |
| Figure 14. | Resulting waveform 3 | 33 |
| Figure 15. | Resulting waveform 4 | 34 |
| Figure 16. | 6-channel direct input block diagram | 36 |
| Figure 17. | ADC characteristics and error definition | 48 |
| Figure 18. | Conversion window generation | 49 |
| Figure 19. | Minimum ON time for digital current sense availability | 50 |
| Figure 20. | Channel's sequence internal stack | 50 |
| Figure 21. | Sequence of channels | 52 |
| Figure 22. | Asynchronous with continuous sampling | 53 |
| Figure 23. | Status registers | 54 |
| Figure 24. | Diagnostics flowchart for digital overload detection | 56 |
| Figure 25. | Open-load OFF-state detection | 57 |
| Figure 26. | Diagnostics flowchart for open-load off-state respectively stuck to V_{CC} failure | 58 |
| Figure 27. | Internal timer process | 60 |
| Figure 28. | One timer step actions | 61 |
| Figure 29. | Power limitation counter flowchart | 62 |
| Figure 30. | Example of behavior channel configuration | 63 |
| Figure 31. | SPI dynamic characteristics | 68 |
| Figure 32. | Switching characteristics | 74 |
| Figure 33. | Normal mode - Short circuit – $PBW < t_{D_Restart}$ | 75 |
| Figure 34. | Normal mode - Short circuit – $PBW > t_{D_Restart}$ | 76 |
| Figure 35. | M0-9 SPI application schematic | 78 |
| Figure 36. | Maximum turn-off current versus inductance - Bulb mode all channels | 79 |
| Figure 37. | Maximum turn-off energy versus inductance - Bulb mode all channels | 79 |
| Figure 38. | Maximum turn-off current versus inductance - LED mode all channels | 80 |
| Figure 39. | Maximum turn-off energy versus inductance - LED mode all channels | 80 |
| Figure 40. | QFN 6x6 PCB footprint | 81 |
| Figure 41. | QFN 6x6 PCB 2 cm^2 | 81 |
| Figure 42. | QFN 6x6 PCB 8 cm^2 | 82 |
| Figure 43. | QFN 6x6 PCB 4 layers | 82 |
| Figure 44. | R_{thJA} vs PCB copper area in open box free air conditions | 83 |
| Figure 45. | QFN 6x6 thermal impedance junction ambient | 84 |
| Figure 46. | Thermal fitting model | 84 |
| Figure 47. | QFN 6x6 package outline | 86 |
| Figure 48. | QFN 6x6 reel 13" | 88 |
| Figure 49. | QFN 6x6 carrier tape | 88 |
| Figure 50. | QFN 6x6 marking information | 89 |

IMPORTANT NOTICE – READ CAREFULLY

STMicroelectronics NV and its subsidiaries (“ST”) reserve the right to make changes, corrections, enhancements, modifications, and improvements to ST products and/or to this document at any time without notice. Purchasers should obtain the latest relevant information on ST products before placing orders. ST products are sold pursuant to ST’s terms and conditions of sale in place at the time of order acknowledgment.

Purchasers are solely responsible for the choice, selection, and use of ST products and ST assumes no liability for application assistance or the design of purchasers’ products.

No license, express or implied, to any intellectual property right is granted by ST herein.

Resale of ST products with provisions different from the information set forth herein shall void any warranty granted by ST for such product.

ST and the ST logo are trademarks of ST. For additional information about ST trademarks, refer to www.st.com/trademarks. All other product or service names are the property of their respective owners.

Information in this document supersedes and replaces information previously supplied in any prior versions of this document.

© 2024 STMicroelectronics – All rights reserved