



Product Change Notification

Date Issued :	November 07, 2024	PCN Number :	515275
Reason for Change :	Change to Product		
Description of Change :	This notification is to inform you about changes that are being made to the part(s) as identified in the list. This change will affect the Fit, Form, Function, or appearance of the parts. Or it may result in a change to the specification or raw material.		
Assessment of Change :	First Article Inspection		
Planned Implementation Date :	May 07, 2025		
Customer Sample Availability Date:	May 03, 2024		
Last date to request Samples by Customer :	December 20, 2024		
Please note if Samples are not requested as per Customer Samples Request date, it may take additional 4-6 weeks to arrange Samples.			
Traceability Code Markings / Date :	No special marking on the product or packaging		

Before Picture

▪ Example products

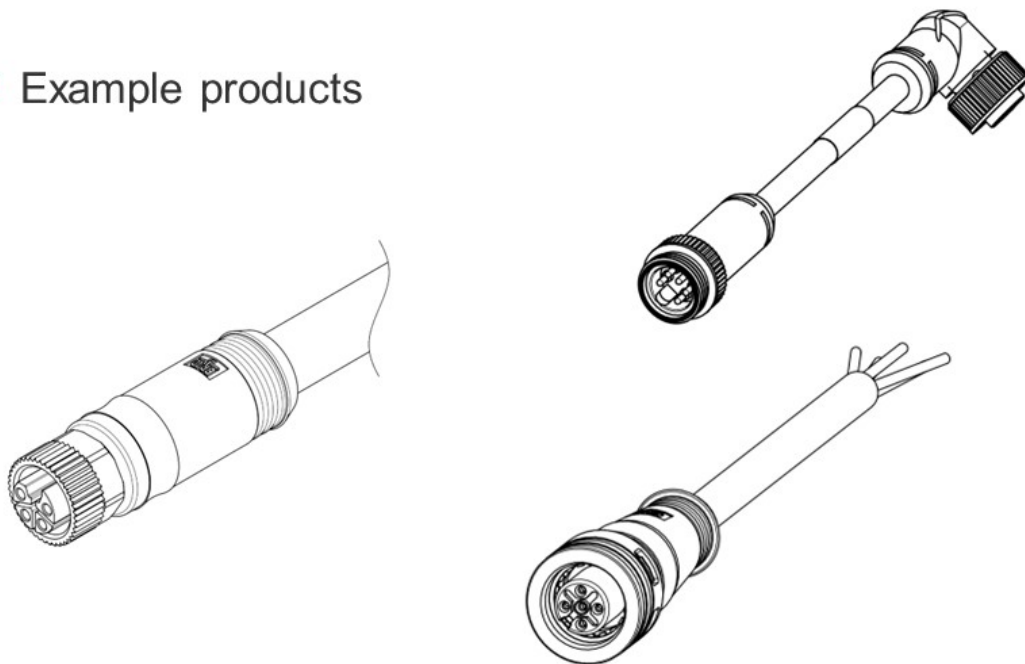

1 1

Molex Confidential Information
 © 2016 Molex – All Rights Reserved. Unauthorized Reproduction/Distribution is Prohibited.



After Picture

Overview

- In an effort to better align our component inventory strategy for the global market what will ensure continuity of supply chain, we change black colorant for overmold material. New colorant was defined and qualified by Molex engineering team.

- Product Impact
 - No impact to fit, form or function

- Part Number Impact
 - See attached impacted parts list

2

Molex Confidential Information
© 2016 Molex – All Rights Reserved. Unauthorized Reproduction/Distribution is Prohibited.



RELEASED

You may address inquires regarding this PCN by clicking on the below link
mailto:pcn_coordinator@molex.com?subject=PCN_Notification:515275
or contact your Local Sales Engineer.

Note: While responding, please retain " PCN Notification : **PCN Notification: 515275** " in the e-mail Subject line for faster response.

[Molex, LLC](#)
2222 Wellington Court
Lisle, IL 60532
TEL (800) 786-6539
www.molex.com