

TLE4973 Evaluation Board User guide

Vertical insertion on external busbar

About this document

This document describes the evaluation board of TLE4973, Infineon's magnetic current sensor for automotive applications with external current rail.

Scope and purpose

The evaluation board is meant to be used by the customer solely for the purpose of evaluation and testing. It is not a commercial product and shall not be used for series production. This board is thus not intend to meet any industrial specifications and shall be operated at room temperature.

Due to its purpose, the evaluation board is not subject to the same procedures as regular products regarding Returned Material Analysis (RMA), Process Change Notification (PCN) and Product Withdraw (PWD).

Intended audience

This document is written for customers who intend to use TLE4973 in current sensing applications.

Evaluation Board

This board will be used during design in, for evaluation and measurement of characteristics, and proof of datasheet specifications.

Note: PCB and auxiliary circuits are NOT optimized for final customer design. Boards do not necessarily meet safety, EMI, quality standards (for example UL, CE) requirements.

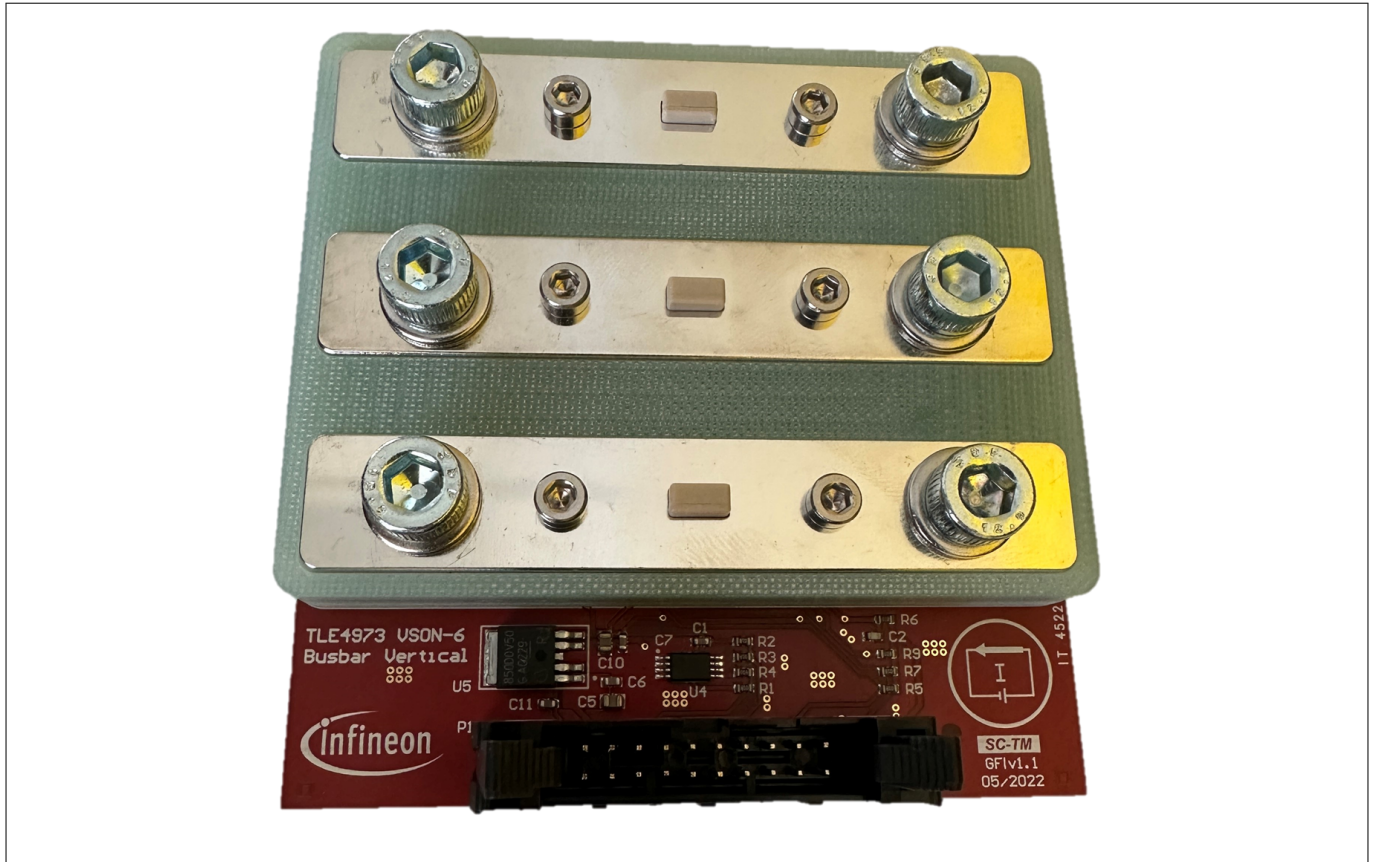

Figure 1 TLE4973 EVAL VER BAR

Table of contents

	Table of contents	3
1	Important notice	4
2	Safety precautions	5
3	The board at a glance	6
3.1	Delivery content	6
3.2	Block diagram	6
3.3	Main features	6
3.4	Board parameters and technical data	6
4	System and functional description	8
4.1	Commissioning	8
4.2	Description of the functional blocks	8
4.3	Sensing Structure Layout & Guidelines	8
5	System design	10
5.1	Schematics	10
5.2	Layout	12
5.3	Bill of material	13
5.4	Connector details	14
6	System performance	16
6.1	Test points	16
6.2	Test results	16
6.2.1	Measurement results	16
6.2.1.1	Sensitivity drift and offset drift over temperature	16
6.2.1.2	Frequency response	17
6.2.1.3	Crosstalk	18
6.2.1.4	Thermal capability	19
6.2.2	Simulation results	19
6.2.2.1	Conductor and insertion resistance	20
6.2.2.2	Transfer factor error due to sensor displacement	22
7	References and appendices	24
7.1	Abbreviations and definitions	24
7.2	References	24
8	Revision history	25
	Disclaimer	26

1 Important notice

1 Important notice

“Evaluation Boards and Reference Boards” shall mean products embedded on a printed circuit board (PCB) for demonstration and/or evaluation purposes, which include, without limitation, demonstration, reference and evaluation boards, kits and design (collectively referred to as “Reference Board”).

Environmental conditions have been considered in the design of the Evaluation Boards and Reference Boards provided by Infineon Technologies. The design of the Evaluation Boards and Reference Boards has been tested by Infineon Technologies only as described in this document. The design is not qualified in terms of safety requirements, manufacturing and operation over the entire operating temperature range or lifetime.

The Evaluation Boards and Reference Boards provided by Infineon Technologies are subject to functional testing only under typical load conditions. Evaluation Boards and Reference Boards are not subject to the same procedures as regular products regarding returned material analysis (RMA), process change notification (PCN) and product discontinuation (PD).

Evaluation Boards and Reference Boards are not commercialized products, and are solely intended for evaluation and testing purposes. In particular, they shall not be used for reliability testing or production. The Evaluation Boards and Reference Boards may therefore not comply with CE or similar standards (including but not limited to the EMC Directive 2004/EC/108 and the EMC Act) and may not fulfill other requirements of the country in which they are operated by the customer. The customer shall ensure that all Evaluation Boards and Reference Boards will be handled in a way which is compliant with the relevant requirements and standards of the country in which they are operated.

The Evaluation Boards and Reference Boards as well as the information provided in this document are addressed only to qualified and skilled technical staff, for laboratory usage, and shall be used and managed according to the terms and conditions set forth in this document and in other related documentation supplied with the respective Evaluation Board or Reference Board.

It is the responsibility of the customer’s technical departments to evaluate the suitability of the Evaluation Boards and Reference Boards for the intended application, and to evaluate the completeness and correctness of the information provided in this document with respect to such application.

The customer is obliged to ensure that the use of the Evaluation Boards and Reference Boards does not cause any harm to persons or third party property. The Evaluation Boards and Reference Boards and any information in this document is provided "as is" and Infineon Technologies disclaims any warranties, express or implied, including but not limited to warranties of non-infringement of third party rights and implied warranties of fitness for any purpose, or for merchantability.

Infineon Technologies shall not be responsible for any damages resulting from the use of the Evaluation Boards and Reference Boards and/or from any information provided in this document. The customer is obliged to defend, indemnify and hold Infineon Technologies harmless from and against any claims or damages arising out of or resulting from any use thereof.

Infineon Technologies reserves the right to modify this document and/or any information provided herein at any time without further notice.

2 Safety precautions

2 Safety precautions

Note: Please note the following warnings regarding the hazards associated with development systems.



Figure 2 Safety Precautions

- **Warning:** Remove or disconnect power from the drive before you disconnect or reconnect wires, or perform maintenance work. Failure to do so may result in personal injury or death.
- **Warning:** Do not keep the programmer connected to the laptop while the board is in use in an inverter. The laptop may be damaged during the operation of the system.
- **Warning:** The evaluation board is intended to be used only in low voltage systems (≤ 50 V).
- **Caution:** The board and device surfaces of the evaluation board may become hot during testing. Hence, necessary precautions are required while handling the board. Failure to comply may cause injury. Please refer to [Chapter 6.2.1.4](#) for an indication of the heating due to the current flow.
- **Caution:** Only personnel familiar with the drive, power electronics and associated machinery should plan, install, commission and subsequently service the system. Failure to comply may result in personal injury and/or equipment damage.
- **Caution:** The evaluation board contains parts and assemblies sensitive to electrostatic discharge (ESD). Electrostatic control precautions are required when installing, testing, servicing or repairing the assembly. Component damage may result if ESD control procedures are not followed. If you are not familiar with electrostatic control procedures, refer to the applicable ESD protection handbooks and guidelines.
- **Caution:** A drive that is incorrectly applied or installed can lead to component damage or reduction in product lifetime. Wiring or application errors such as undersizing the motor, supplying an incorrect or inadequate AC supply, or excessive ambient temperatures may result in system malfunction.
- **Caution:** The evaluation board is shipped with packing materials that need to be removed prior to installation. Failure to remove all packing materials that are unnecessary for system installation may result in overheating or abnormal operating conditions.

3 The board at a glance

3 The board at a glance

TLE4973 evaluation board is developed to familiarize the users with TLE4973 current sensor for design in support and evaluation purposes. The complete evaluation kit consists of this board and the programmer board, which is explained in [1]. The programmer board supplies the sensors on the evaluation board and allows a fast and easy interfacing to each sensor. If the programmer board is not used, power supply has to be provided externally by the user.

3.1 Delivery content

The delivery content consist in TLE4973 evaluation board.

3.2 Block diagram

The evaluation board includes three TLE4973 coreless magnetic current sensors for testing in three-phase systems. The evaluation board has been designed to operate safely in low voltage systems (≤ 50 V). It is recommended to disconnect the USB cable between the programmer and the laptop while the system is in operation, in order to avoid damages to the laptop.

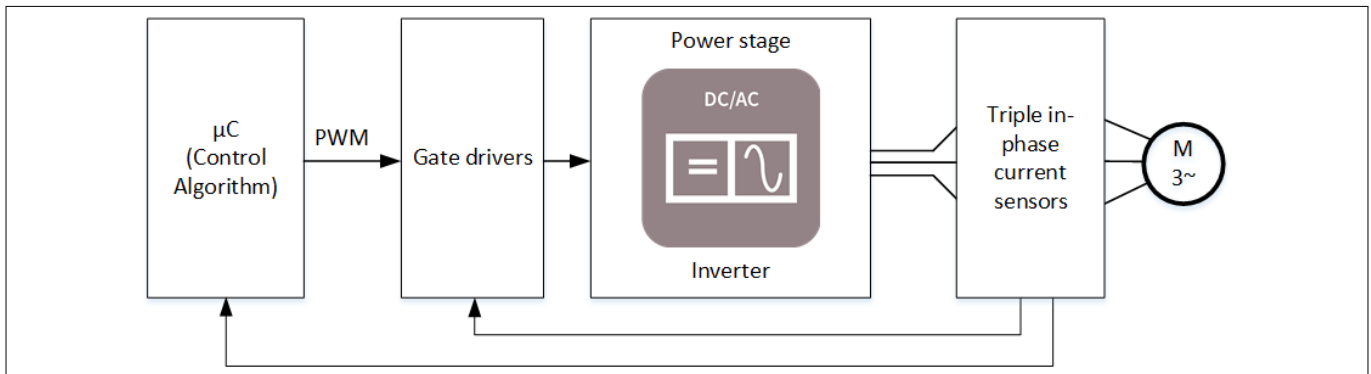

Figure 3 Block diagram of the evaluation board in use in a three-phase system

3.3 Main features

- Three TLE4973 sensors, for testing in three-phase systems;
- On board EEPROM to store board settings;
- Compatible with Infineon Current Sensor Programmer [1]

3.4 Board parameters and technical data

Table 1 Evaluation Board Overview

Product	TLE4973-RE35S5-S0010
Package	PG-VSON-6
Evaluation board name	TLE4973 EVAL VER BAR
Evaluation board order number	SP005853847
Insertion method name	Vertical insertion on external bus-bar
Full scale (FS)	± 919.97 A
Typical current rail transfer factor	15.41 μ T/A
Typical sensor sensitivity	126.95 mV/mT (S4)
Typical evaluation board sensitivity	1.96 mV/A

(table continues...)

3 The board at a glance

Table 1 (continued) Evaluation Board Overview

Product	TLE4973-RE35S5-S0010
Output mode	Single-ended AOUT only
OCD threshold	1274.54 A (139% of FS)
DCDI address [Sensor 1]	0xA _{hex}
DCDI address [Sensor 2]	0xB _{hex}
DCDI address [Sensor 3]	0xC _{hex}
Typical insertion resistance	2 $\mu\Omega$
Bus-bar thickness	2 mm
Bus-bar width	14 mm

4 System and functional description

4 System and functional description

4.1 Commissioning

If the evaluation board is used in combination with the Infineon programmer board [1], it is sufficient to connect the two boards and follow the instructions on the GUI [1].

If instead the evaluation board is used as stand-alone, then the user has to supply the board using pin 17 (VS+, LDO input). In order to enable the onboard LDO, pin 19 (EN) has to be connected to the same supply voltage. The supply voltage must be in the range [6,9] V. Please refer to [Chapter 5.4](#) for the complete pinout of the evaluation board connector.

4.2 Description of the functional blocks

The board consists of three TLE4973 current sensors to accurately sense AC and DC currents, a EEPROM to store the board settings, a LDO (Low Drop Out) regulator to stabilize the supply voltage of the sensors and a connector to connect to the Infineon programmer board [1]. For additional information about TLE4973 please refer to the user manual [2] and datasheet [3]. Guidelines about sensing structure design are given in the dedicated application note [4].

4.3 Sensing Structure Layout & Guidelines

The three sensors are mounted on a PCB and fit vertically within the slit of the bus-bar. The bus-bar is 14 mm wide and 2 mm thick, while the slit width is 3.2 mm. Please refer to the sensing structure design application note [4] for further guidelines.

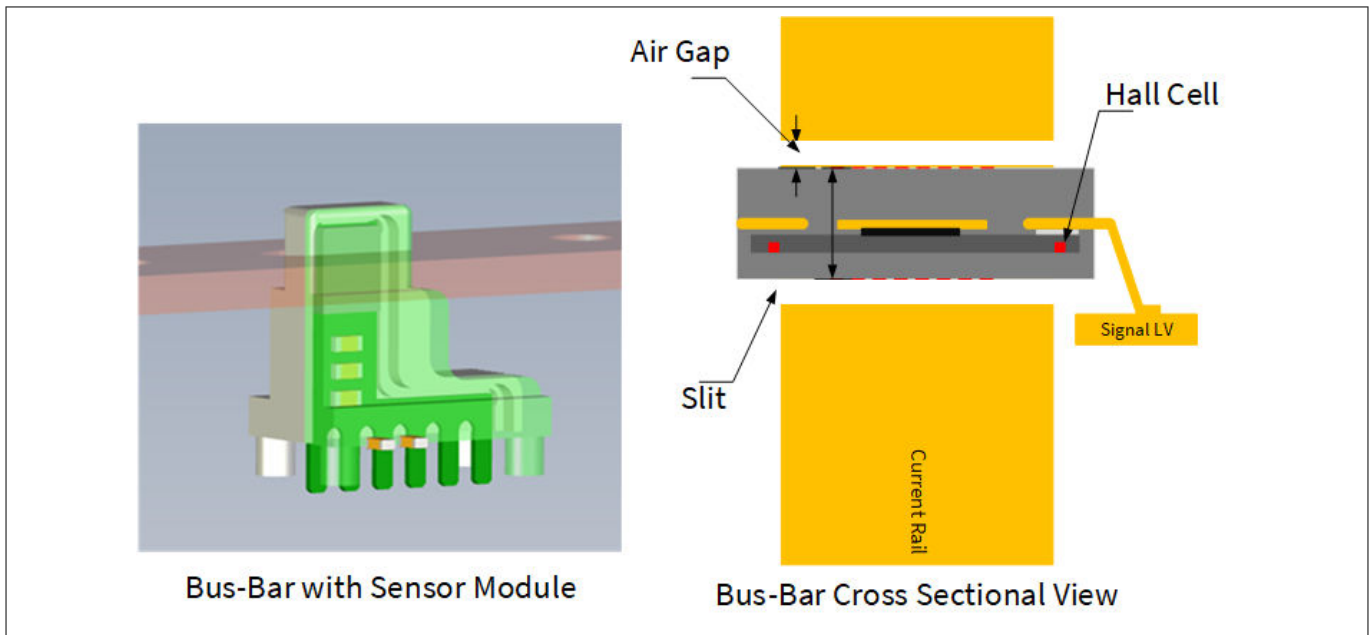

Figure 4 Sensing structure overview

4 System and functional description

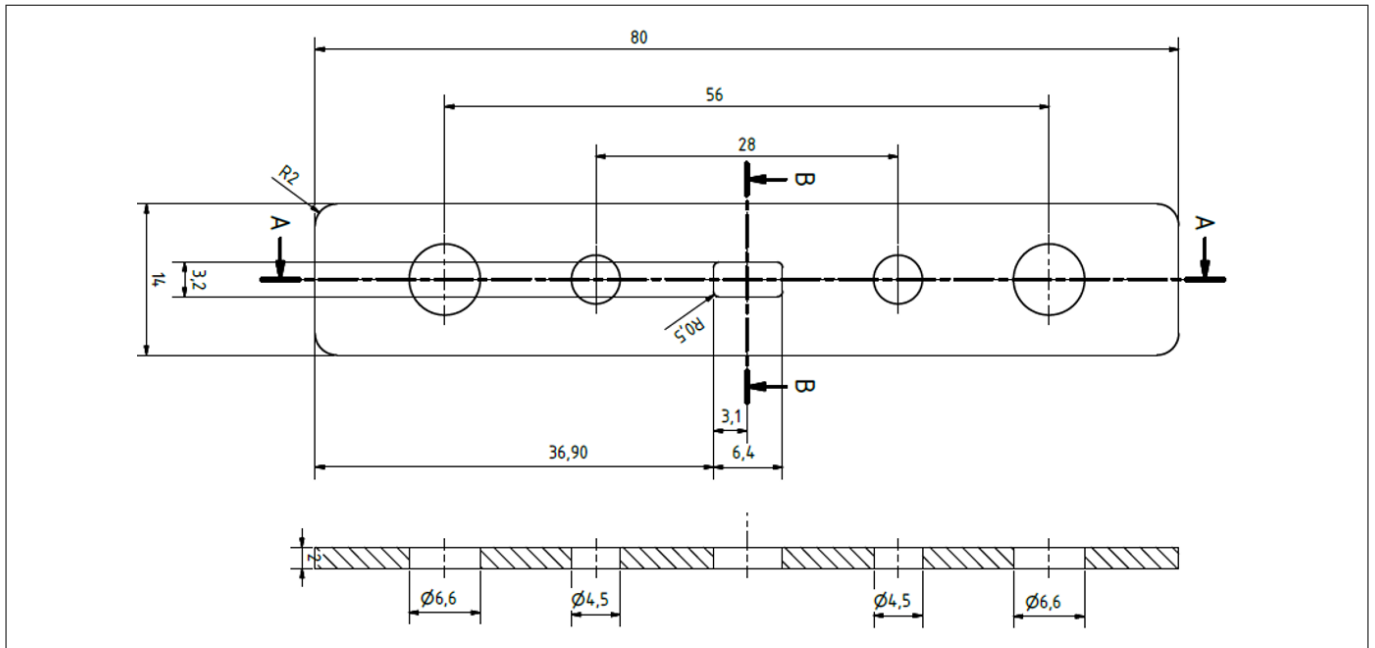

Figure 5 Bus-bar details

5 System design

5 System design

5.1 Schematics

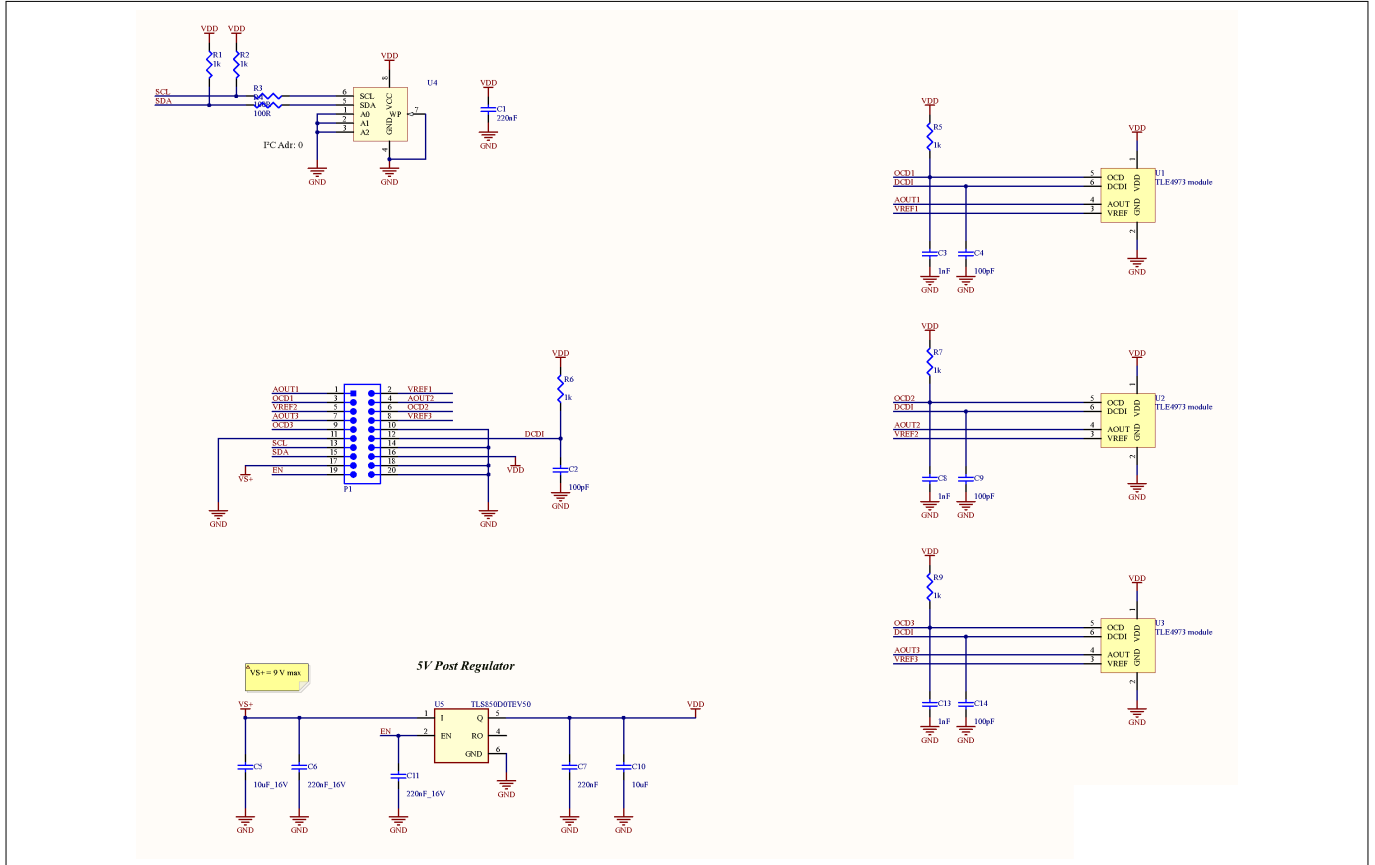

Figure 6 TLE4973 evaluation board schematic - main PCB

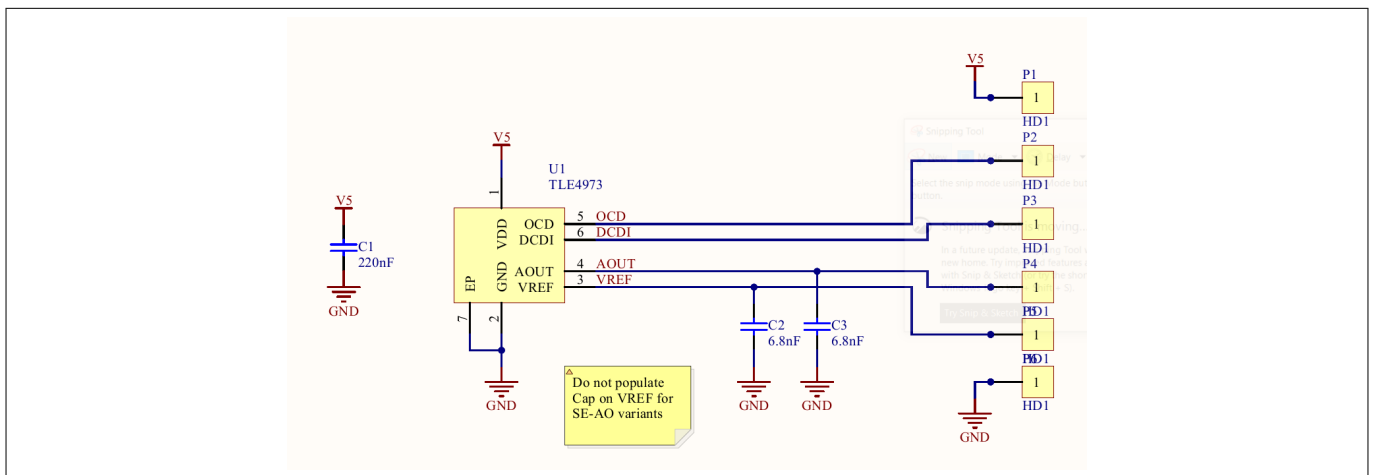

Figure 7 TLE4973 evaluation board schematic - sensor module PCB

In order to suppress the high frequency noise and meet the EMC and ESD requirements, the following capacitors have been implemented:

- A 1 nF bypass capacitor at the OCD pin of the sensors;
- A 100pF bypass capacitor at the DCDI pin of the sensors.

5 System design

Additionally, OCD and DCDI pins of the sensors are connected to 1 k Ω pull-up resistors, as they are open drain pins. A voltage regulator is implemented to supply the sensors with a stable voltage.

5 System design

5.2 Layout

TLE4973 evaluation board main PCB consists of two 35 µm metallization layers, as shown in the figure below.

#	Name	Material	Type	Thickness
	Top Overlay		Overlay	
	Top Solder	Solder Resist	Solder Mask	0.02mm
1	L1_Top	Copper	Signal	0.035mm
	Dielectric1	FR-4	Core	1.44mm
2	L14_Bot	Copper	Signal	0.035mm
	Bottom Solder	Solder Resist	Solder Mask	0.02mm
	Bottom Overlay		Overlay	

Figure 8 Evaluation board layer stack up - main PCB

TLE4973 evaluation board sensor module PCB is thinner in order to fit in the plastic module. The layer stack is shown in the figure below.

#	Name	Material	Type	Thickness
	Top Overlay		Overlay	
	Top Solder	Solder Resist	Solder Mask	0.01mm
1	L1_Top		Signal	0.035mm
	FR4	FR-4	Core	0.31mm
2	L14_Bot		Signal	0.035mm
	Bottom Solder	Solder Resist	Solder Mask	0.01mm
	Bottom Overlay		Overlay	

Figure 9 Evaluation board layer stack up - sensor module PCB

The figure below shows the top and bottom layer of the evaluation board. Please contact your local Infineon sales office to receive the Gerber files.

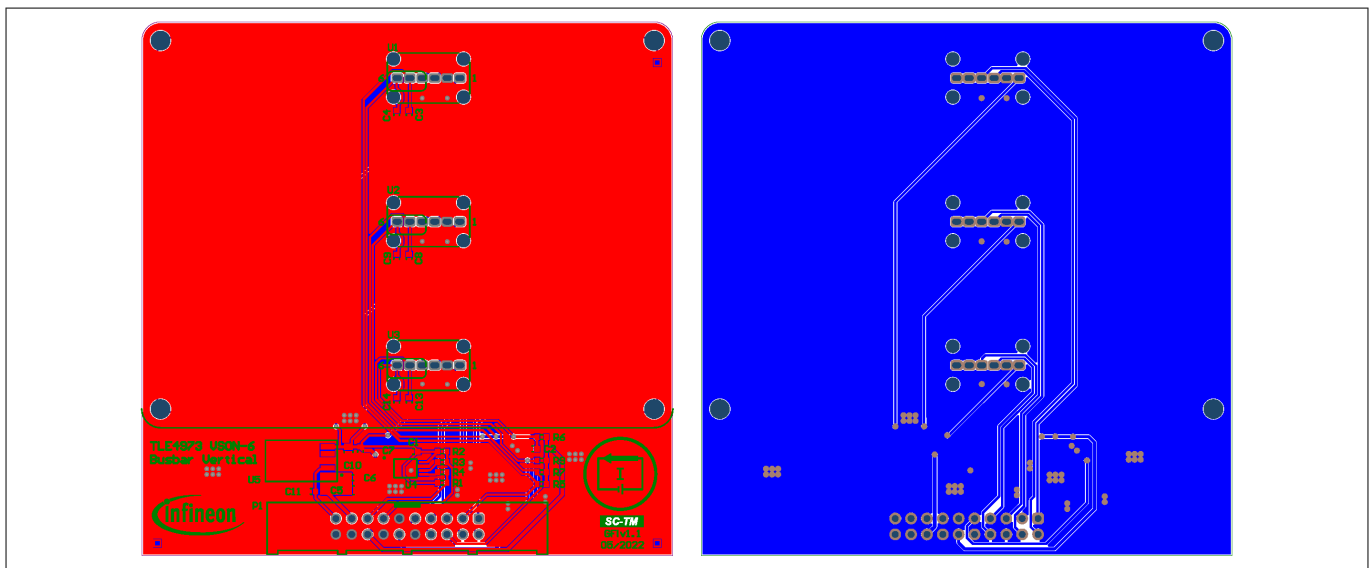

Figure 10 Evaluation board PCB layout. Top layer (red, left) and bottom layer (blue, right)

5 System design

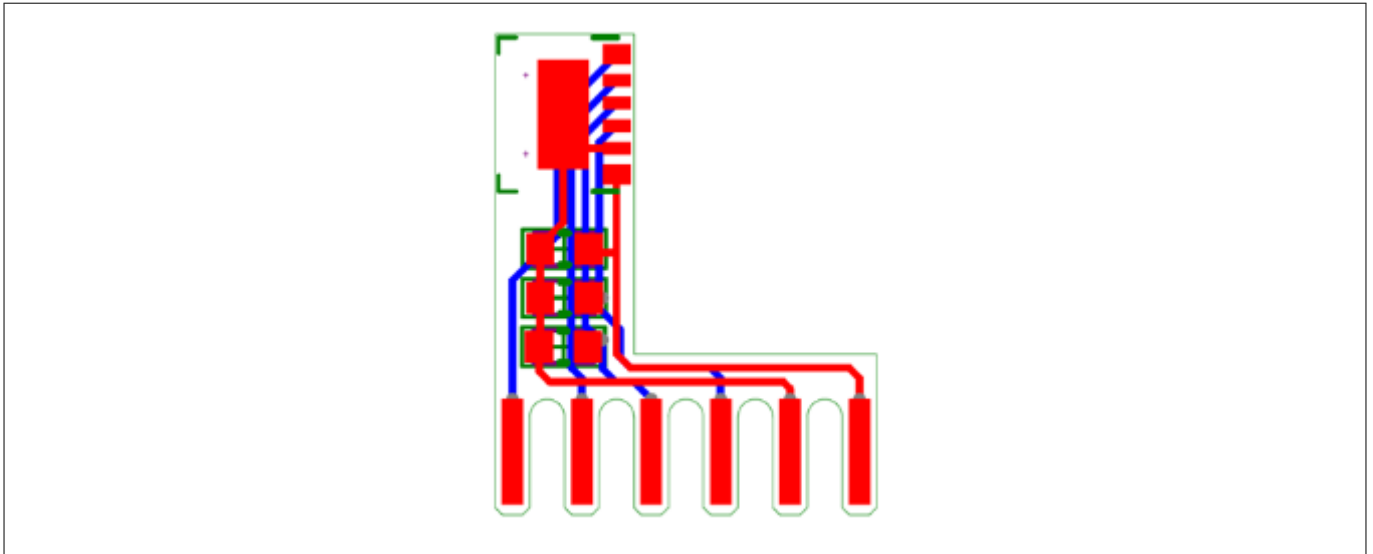

Figure 11 Evaluation board PCB layout - sensor module

AOUT and VREF tracks of each sensor are traced in parallel on the PCB in order to minimize the common mode noise on the output signal. Additionally, ground planes are used to protect the signal tracks and reduce the parasitic inductive couplings. No heat sink or other conductor material shall be placed on the same position of the sensors to avoid the error induced due to the eddy currents.

5.3 Bill of material

Table 2 Bill of Material - main PCB

Quantity	Designator	Value	Comment	Footprint
1	U5	TLS850D0TEV50	LDO	PG-TO252-5
1	U4	M24C02	Onboard EEPROM	TSSOP8_W
3	U1, U2, U3	TLE4973 module	TLE4973 module	TLE4973 module
2	R3, R4	100R	Res	R0603
6	R1, R2, R5, R6, R7, R9	1k	Res	R0603
1	P1	Wurth 61202022821	-	-
1	C10	10uF	Cap	C0805
2	C6, C11	220nF_16V	Cap	C0603
1	C5	10uF_16V	Cap	C0805
3	C3, C8, C13	1nF	Cap	C0603
4	C2, C4, C9, C14	100pF	Cap	C0603
2	C1, C7	220nF	Cap	C0603

Table 3 Bill of Material - sensor module PCB

Quantity	Designator	Value	Comment	Footprint
1	C1	220nF	Cap	C0603
1	C2	6.8nF	DNP for SE-AO	C0603

(table continues...)

5 System design

Table 3 (continued) Bill of Material - sensor module PCB

Quantity	Designator	Value	Comment	Footprint
1	C3	6.8nF	Cap	C0603
1	U1	TLE4973	TLE4973 current sensor	PG-VSON-6-4

5.4 Connector details

The evaluation board connector establishes the connection between the evaluation board and the programmer board. Please refer to the programmer user guide [1] for details about the programmer.

Table 4 Evaluation board connector pinout

Pin Number	Pin name	Pin function
1	AOUT1	Analog output voltage of sensor 1
2	VREF1	Reference voltage of sensor 1
3	OCD1	Over Current Detection of sensor 1 (open drain)
4	AOUT2	Analog output voltage of sensor 2
5	VREF2	Reference voltage of sensor 2
6	OCD2	Over Current Detection of sensor 2 (open drain)
7	AOUT3	Analog output voltage of sensor 3
8	VREF3	Reference voltage of sensor 3
9	OCD3	Over Current Detection of sensor 3 (open drain)
10	GND	Ground connection
11	GND	Ground connection
12	DCDI	Digital Control Diagnostic Interface. One wire, open drain, connected to all sensors. UART protocol.
13	SCL	Clock for communication with external EEPROM on Infineon's evaluation boards
14	GND	Ground connection
15	SDA	Data link for communication with external EEPROM on Infineon's evaluation boards
16	VDD	5 V supply voltage, connected to each sensor on VDD pin. This voltage is generated onboard by the LDO

(table continues...)

5 System design

Table 4 (continued) Evaluation board connector pinout

17	VS+	Supply voltage of the evaluation board. Connected to LDO input. To be used to supply the evaluation board as standalone. The voltage must be in the range [6,9] V
18	GND	Ground connection
19	EN	LDO enable. It must be connected to VS+ when the evaluation board is used as standalone
20	GND	Ground connection

6 System performance

6 System performance

6.1 Test points

The output voltage of the three sensors, as well as the OCD signals have been measured from the evaluation board connector. Please refer to [Chapter 5.4](#) for the complete pinout of the evaluation board connector.

6.2 Test results

6.2.1 Measurement results

This section discusses the results of the measurements performed in the laboratory on the evaluation board. The following measurements have been performed:

1. Sensitivity drift and offset drift over temperature
2. Frequency response
3. Crosstalk
4. Thermal capability

6.2.1.1 Sensitivity drift and offset drift over temperature

The figures below show the TLE4973 evaluation board measurement results of sensitivity drift and offset over temperature when the sensor is placed in the nominal position. The results show extremely stable sensitivity and small offset across the whole temperature range. The absolute value of sensitivity used as target for calibration is shown in [Chapter 3.4](#).

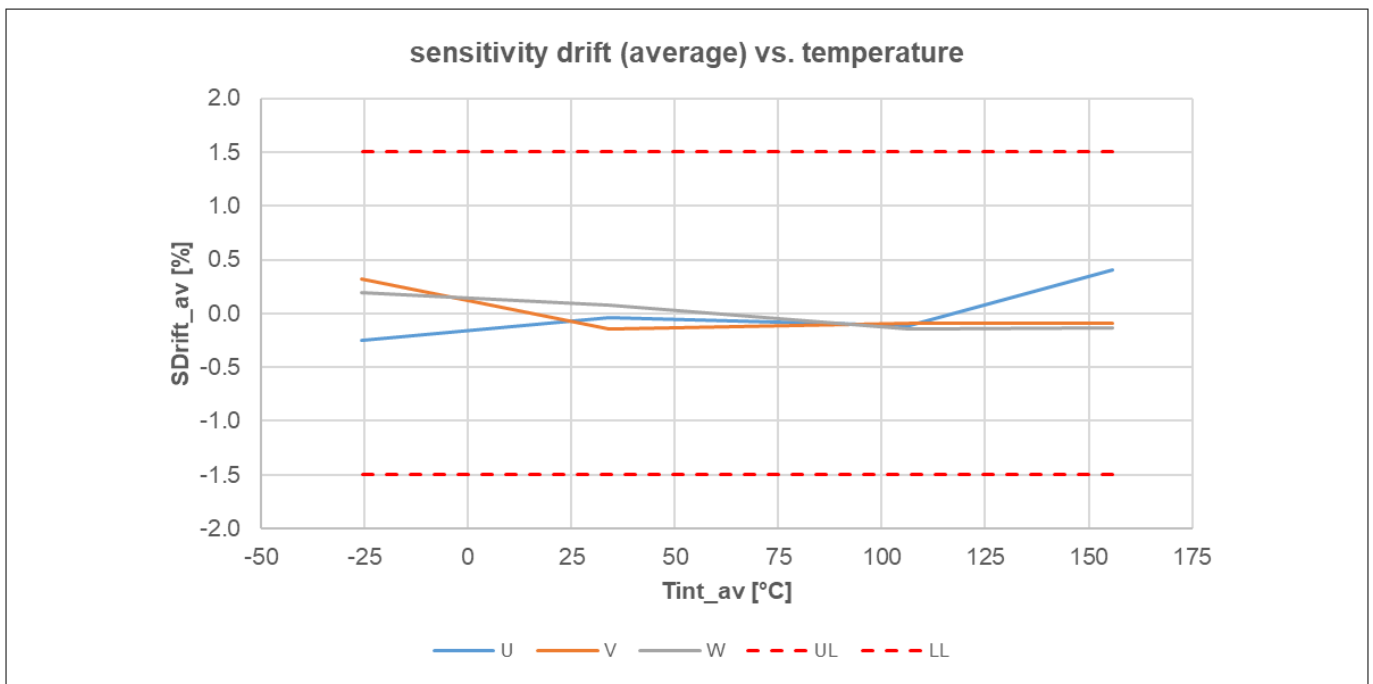

Figure 12 Sensitivity drift over temperature with respect to average value

6 System performance

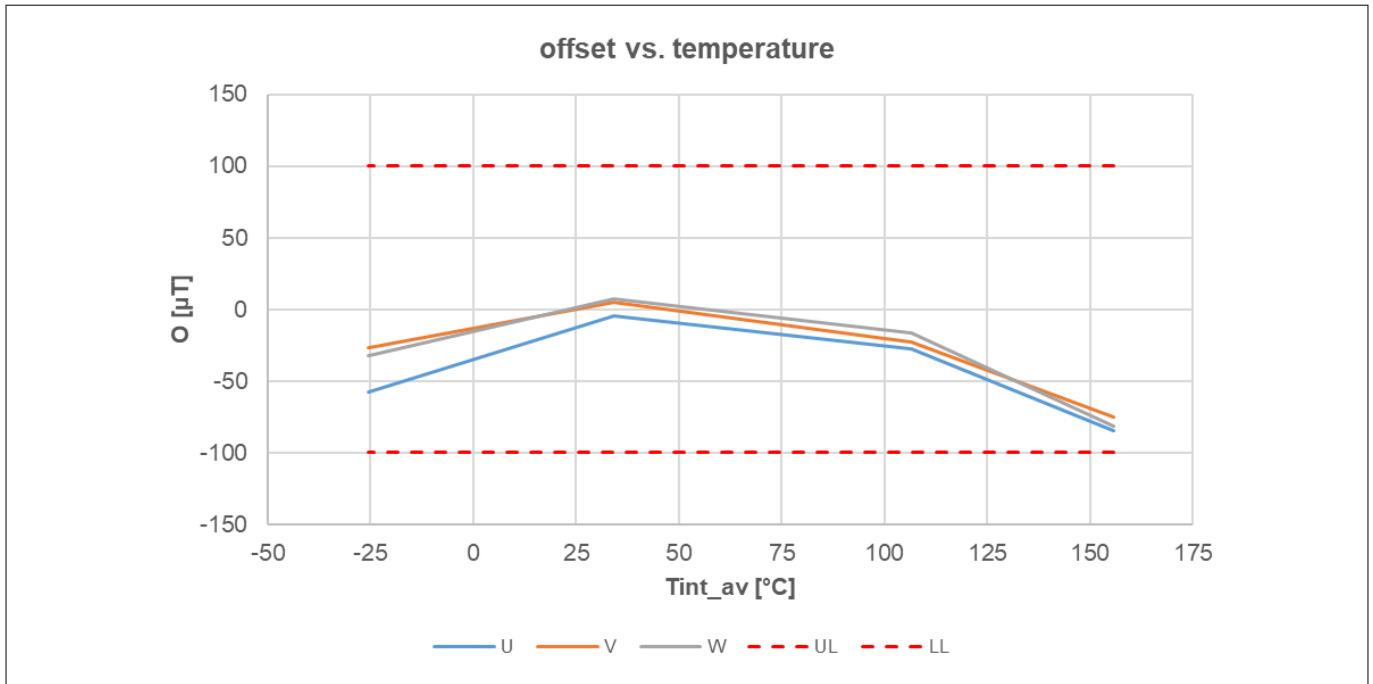

Figure 13 Offset drift over temperature

6.2.1.2 Frequency response

The figures below show the TLE4973 evaluation board measurement results of frequency response (gain and phase) when the sensor is placed in the nominal position. Two out of three sensors have been measured. A comparison with results from Finite Element Method (FEM) simulations is also provided. The Gain plots are normalized to the DC gain.

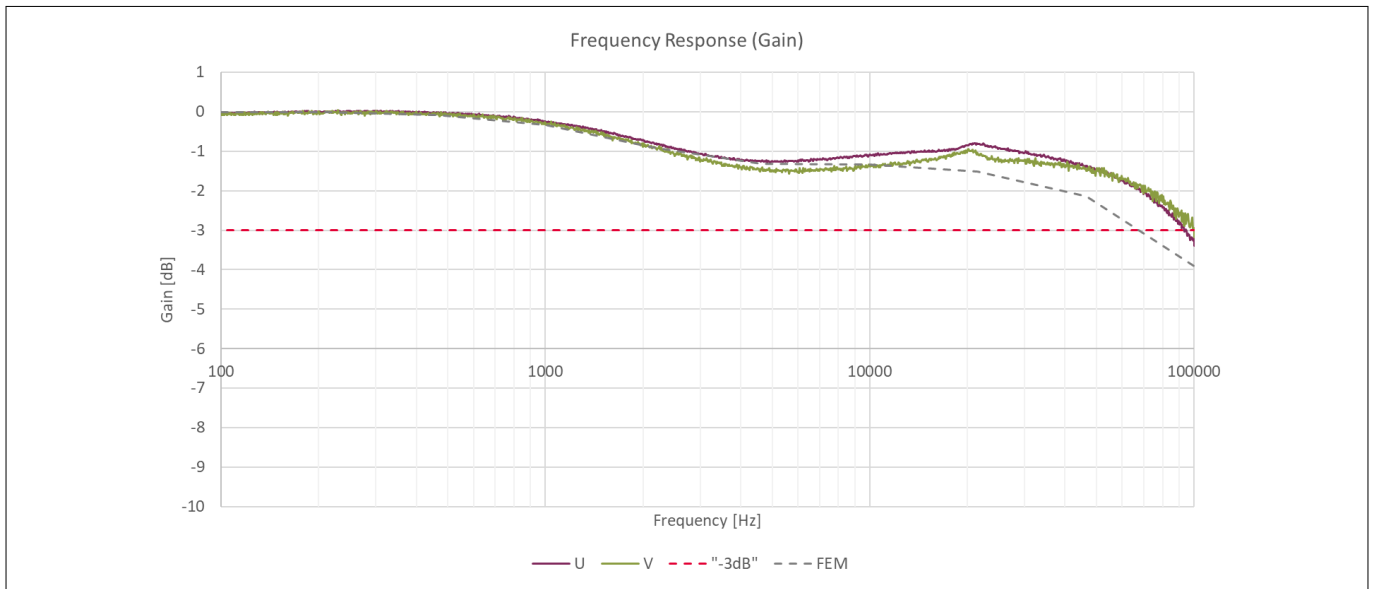

Figure 14 Frequency Response (Gain)

6 System performance

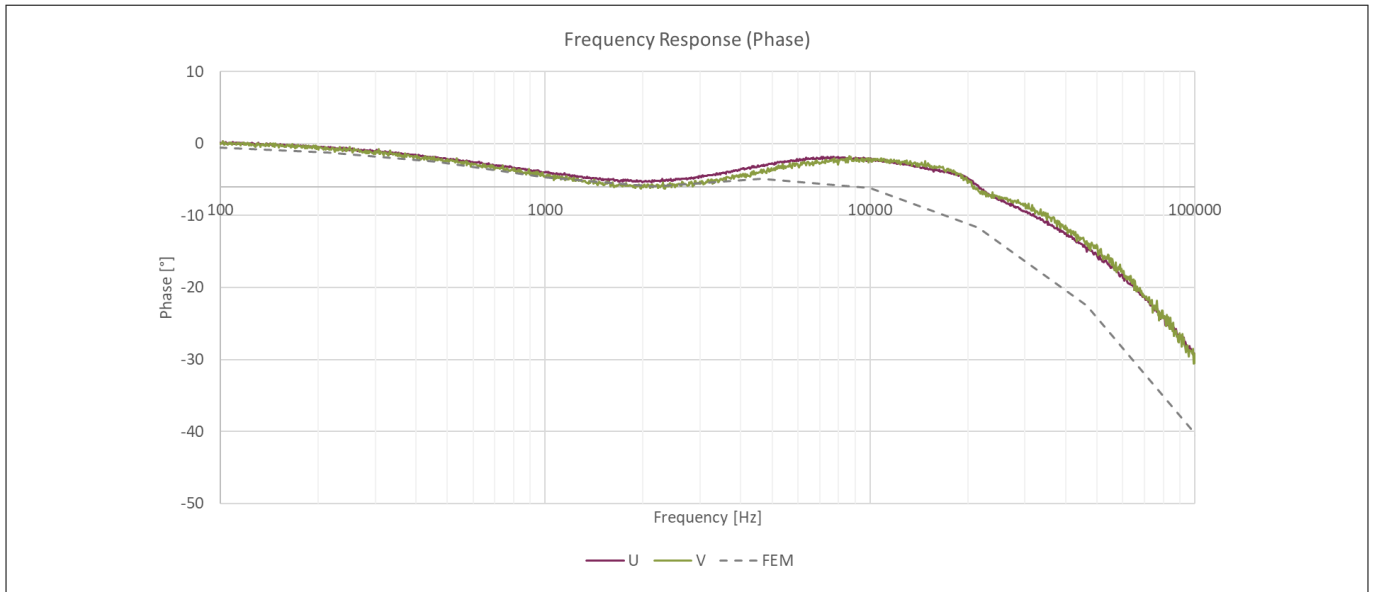

Figure 15 **Frequency Response (Phase)**

6.2.1.3 Crosstalk

The crosstalk is defined as the sensitivity error due to the magnetic stray field generated by the neighboring conductive lines. The crosstalk can be compensated with the “Matrix compensation method” in the microcontroller software. For further information, please refer to the programming board user guide [1] and device user manual [2].

Furthermore, the crosstalk can be reduced orienting the sensors differently with respect to each other, so that the respective sensing elements would see the same field coming from the neighboring conductive lines. Detailed explanation is provided in the application note [4].

The table below shows the sensitivity error due to the crosstalk before the compensation.

Table 5 **Crosstalk**

Active phase	S [%]		
	U	V	W
U	100	2.67	0.59
V	2.78	100	2.73
W	0.58	2.92	100

6 System performance

6.2.1.4 Thermal capability

The following figure shows the heating of the board and device when a current flows in the evaluation board. The temperature is read out by the sensor over time and the measurement is stopped when a temperature of approximately 80°C is detected. The measurement shows that a cooling of the board is needed, if high currents are applied.

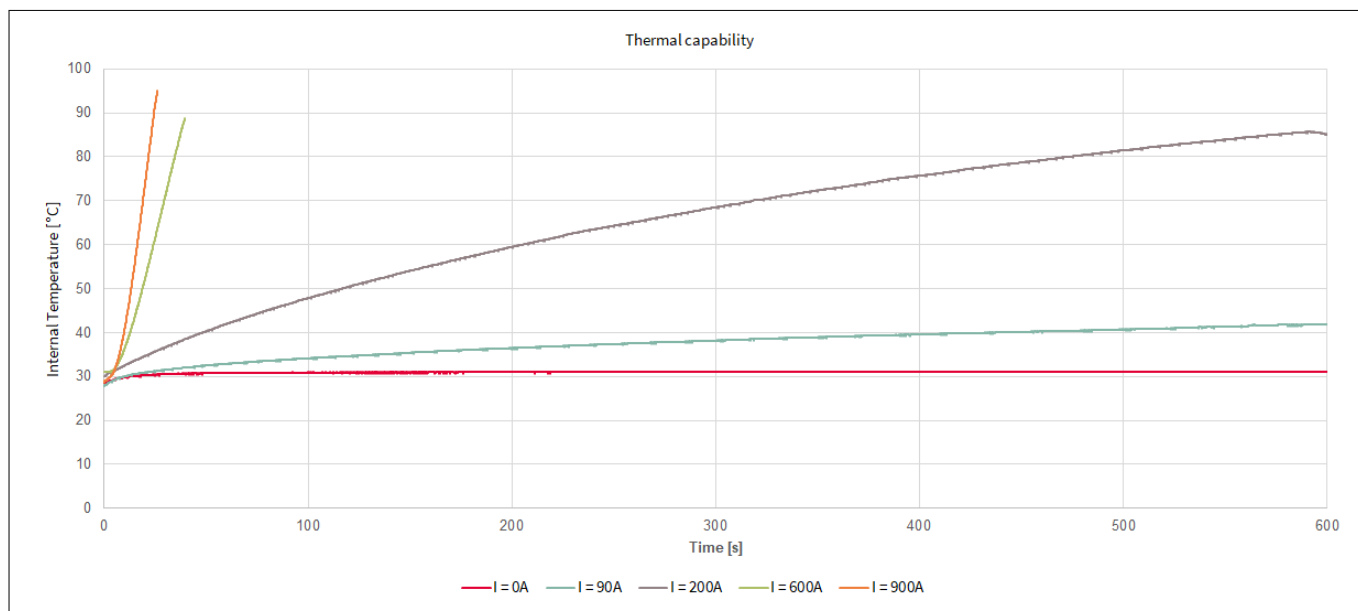

Figure 16 Thermal capability

6.2.2 Simulation results

This section discusses the results of the simulations performed in ANSYS Maxwell 3D on the evaluation board to complement the results from measurements. The following simulations have been performed:

1. Conductor and insertion resistance
2. Transfer factor error due to sensor displacement

6 System performance

6.2.2.1 Conductor and insertion resistance

The insertion resistance indicates the additional resistance caused by the sensing structure at 25°C. The simulations are performed with and without slit in the conductor by applying 1 A of current. Simulation results are shown in the figure below. Please note that the legend shows a voltage [V], which is equivalent to resistance [Ω], being the applied current 1 A.

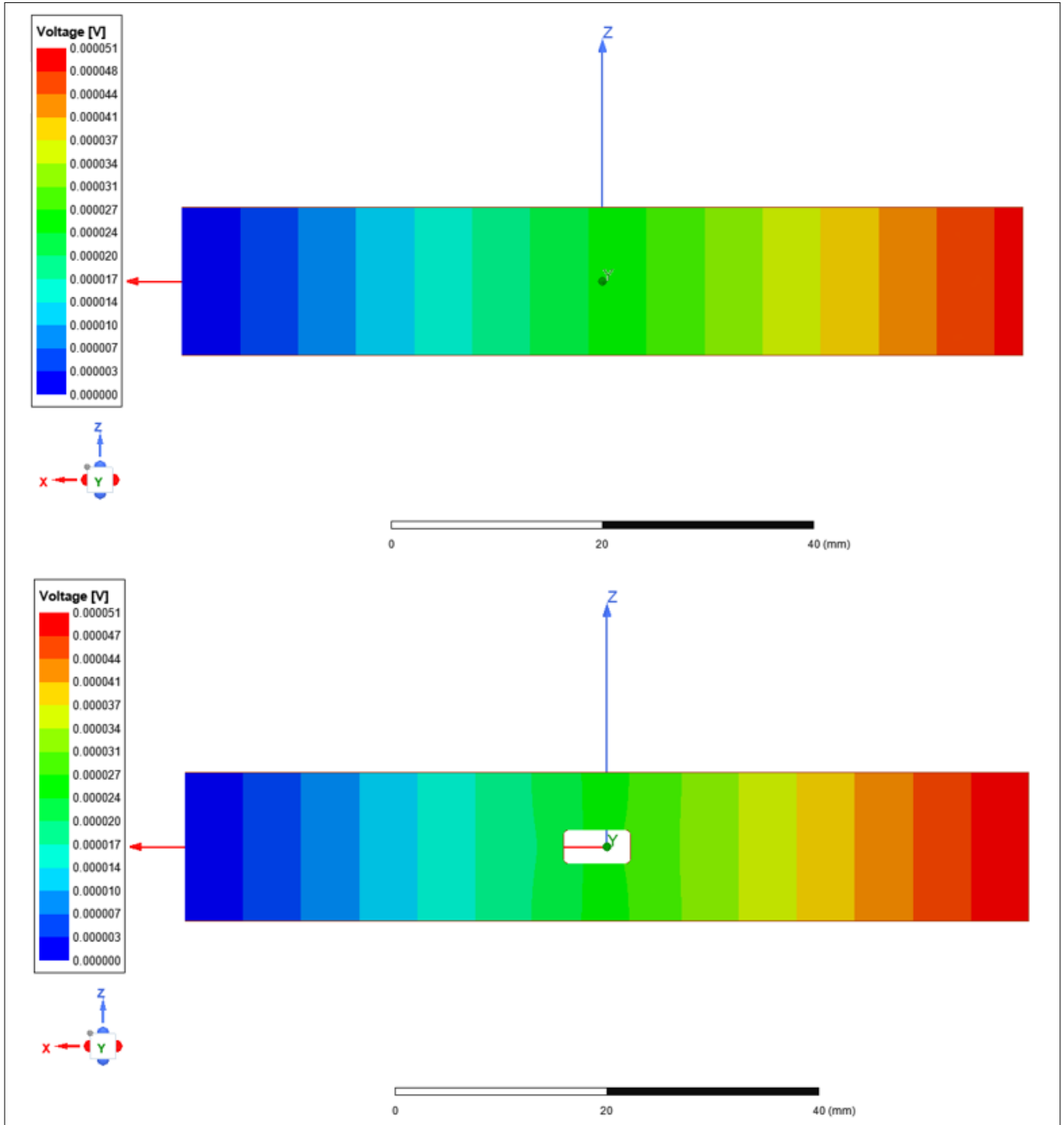

Figure 17 Conductor resistance, without slit (top) and with slit (bottom)

The table below shows the simulated resistance of the conductor with and without slit and the calculated insertion resistance.

6 System performance

Table 6 Evaluation Board Conductor Resistance

Parameter	Value [$\mu\Omega$]
Conductor resistance without slit	49 $\mu\Omega$
Conductor resistance with slit	51 $\mu\Omega$
Insertion resistance	2 $\mu\Omega$
Conductor resistance increase	4.08%

6 System performance

6.2.2.2 Transfer factor error due to sensor displacement

The following figures show the transfer factor variation due to sensor displacement in the x, y, and z-axis direction. The transfer factor is defined in $\mu\text{T}/\text{A}$ and the typical value is shown in [Chapter 3.4](#).

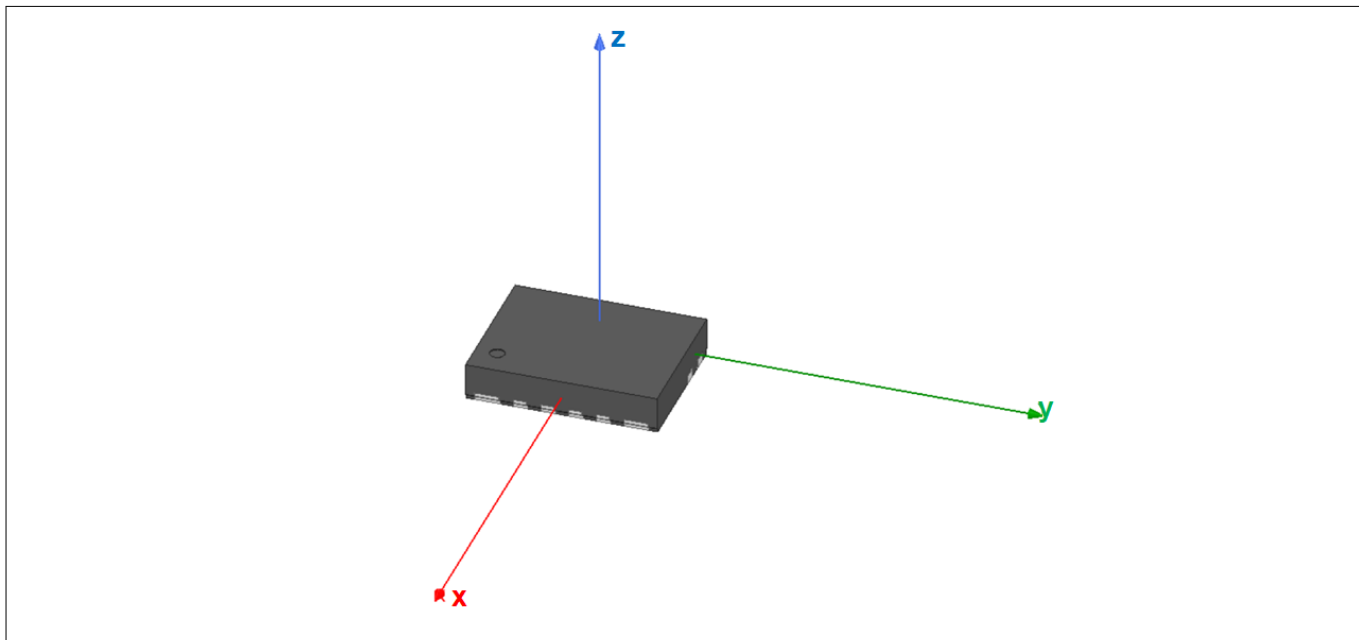

Figure 18 Reference system for sensor displacement simulations



Figure 19 Transfer factor error due to sensor displacement in x direction

6 System performance

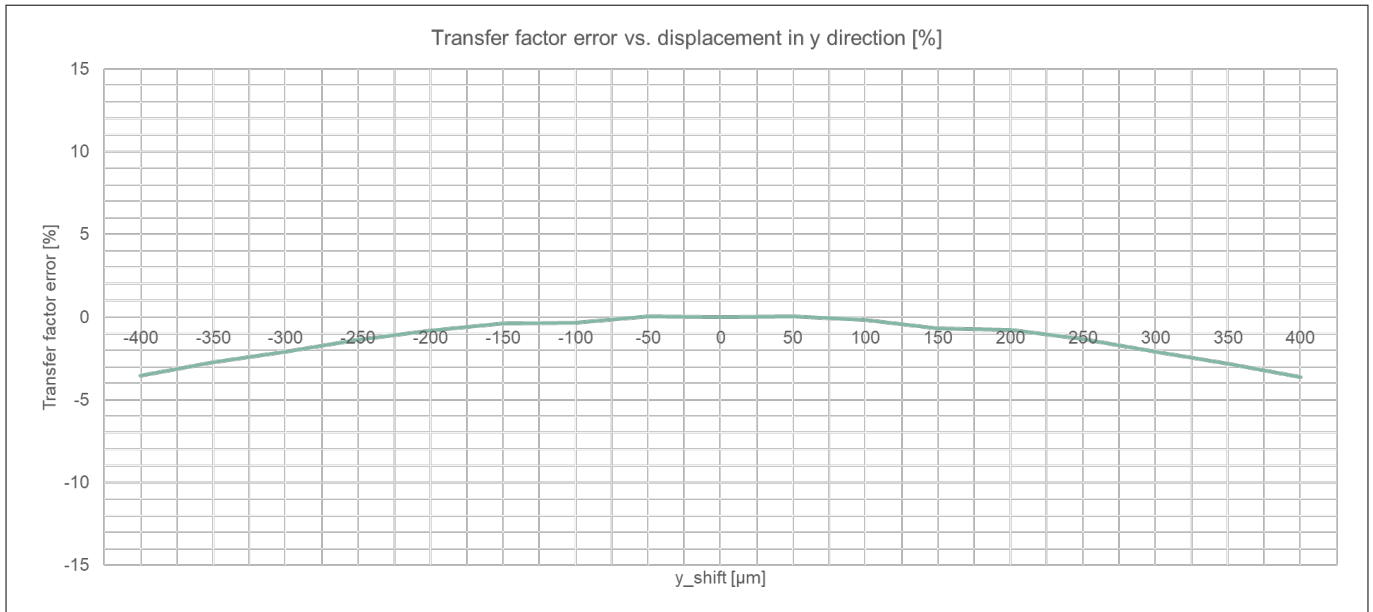

Figure 20 Transfer factor error due to sensor displacement in y direction

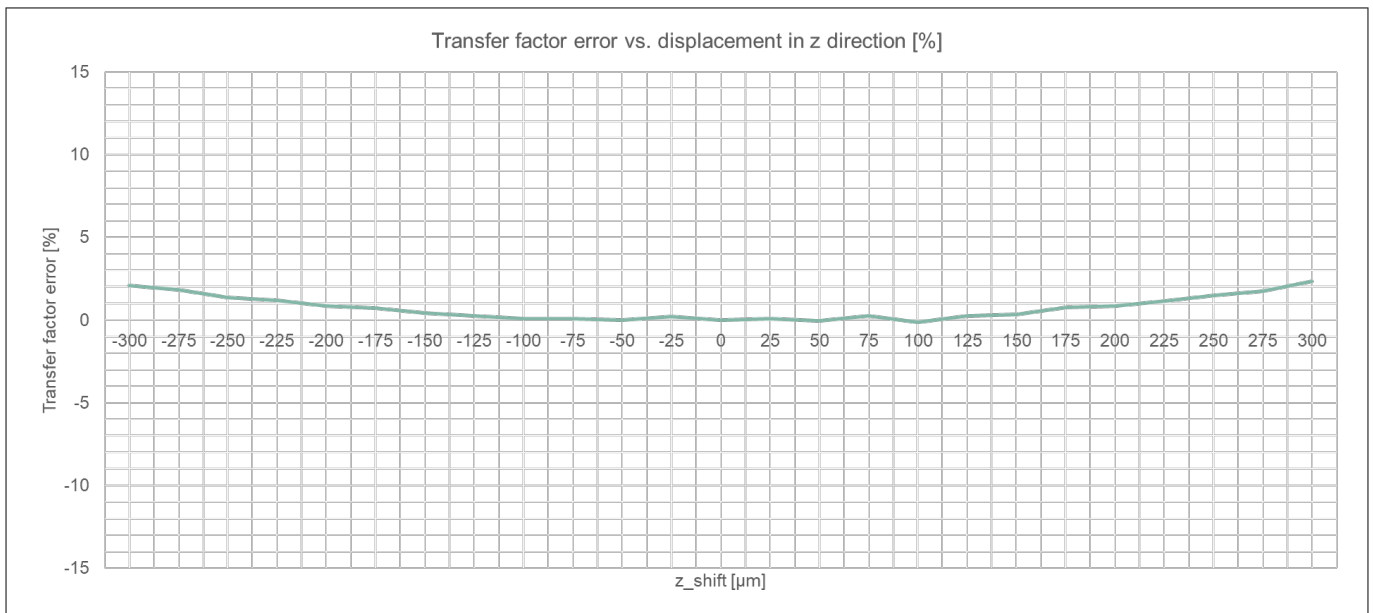

Figure 21 Transfer factor error due to sensor displacement in z direction

7 References and appendices

7.1 Abbreviations and definitions

Notation	Description
AC	Alternating Current
CE	European Conformity
DC	Direct Current
EMC	Electro-Magnetic Compatibility
EMI	Electro-Magnetic Interference
EEPROM	Electrically Erasable Programmable Read-Only Memory
ESD	Electro-Static Discharge
FEM	Finite Element Method
GUI	Graphical User Interface
LDO	Low Drop Out
OCD	Over Current Detection
PCB	Printed Circuit Board
PCN	Process Change Notification
PD	Product Discontinuation
PWD	Product Withdraw
RMA	Returned Material Analysis
SCL	Serial Clock
SDA	Serial Data
UL	Underwriters Laboratories
USB	Universal Serial Bus
DNP	Do Not Populate

7.2 References

[1] Infineon-TLE4973-Current_Sensor_Programmer-UG-vxx_xx-EN

[2] Infineon-TLE4973-User_manual-vxx_xx-EN

[3] Infineon-TLE4973-RE35x5-S0010-DS-vxx_xx-EN.pdf; Infineon-TLE4973-RxxxT5-S0010-DS-vxx_xx-EN.pdf; Infineon-TLE4973-xE35x5-S0001-DS-vxx_xx-EN.pdf; Infineon-TLE4973-xxxxT5-S0001-DS-vxx_xx-EN.pdf

[4] Infineon-TLE4973-Sensing_Structure_Design-AN-vxx_xx-EN

8 Revision history

8 Revision history

Table 7 **Revision History**

Document version	Date of release	Description of changes
1.0	2023-02-27	Initial release

Trademarks

All referenced product or service names and trademarks are the property of their respective owners.

Edition 2023-02-27

Published by

Infineon Technologies AG

81726 Munich, Germany

© 2023 Infineon Technologies AG

All Rights Reserved.

Do you have a question about any aspect of this document?

Email: erratum@infineon.com

Document reference

IFX-jmp1666594843457

Important notice

The information given in this document shall in no event be regarded as a guarantee of conditions or characteristics ("Beschaffheitsgarantie").

With respect to any examples, hints or any typical values stated herein and/or any information regarding the application of the product, Infineon Technologies hereby disclaims any and all warranties and liabilities of any kind, including without limitation warranties of non-infringement of intellectual property rights of any third party.

In addition, any information given in this document is subject to customer's compliance with its obligations stated in this document and any applicable legal requirements, norms and standards concerning customer's products and any use of the product of Infineon Technologies in customer's applications.

The data contained in this document is exclusively intended for technically trained staff. It is the responsibility of customer's technical departments to evaluate the suitability of the product for the intended application and the completeness of the product information given in this document with respect to such application.

Warnings

Due to technical requirements products may contain dangerous substances. For information on the types in question please contact your nearest Infineon Technologies office.

Except as otherwise explicitly approved by Infineon Technologies in a written document signed by authorized representatives of Infineon Technologies, Infineon Technologies' products may not be used in any applications where a failure of the product or any consequences of the use thereof can reasonably be expected to result in personal injury.