

## Final datasheet

### EasyDUAL module with TRENCHSTOP™ IGBT7 and emitter controlled 7 diode and PressFIT / NTC

#### Features

- Electrical features
  - $V_{CES} = 1200\text{ V}$
  - $I_{C\text{ nom}} = 75\text{ A} / I_{CRM} = 150\text{ A}$
  - Overload operation up to  $175^{\circ}\text{C}$
  - Low  $V_{CE,\text{sat}}$
  - TRENCHSTOP™ IGBT7
  - Suitable Infineon gate drivers can be found under <https://www.infineon.com/gdfinder>
- Mechanical features
  - High power density
  - Compact design
  - $\text{Al}_2\text{O}_3$  substrate with low thermal resistance
  - PressFIT contact technology
  - 2.5 kV AC 1 minute insulation
  - Integrated NTC temperature sensor



Typical appearance

#### Potential applications

- Motor drives
- Air conditioning
- Auxiliary inverters
- Servo drives
- UPS systems

#### Product validation

- Qualified for industrial applications according to the relevant tests of IEC 60747, 60749 and 60068

#### Description

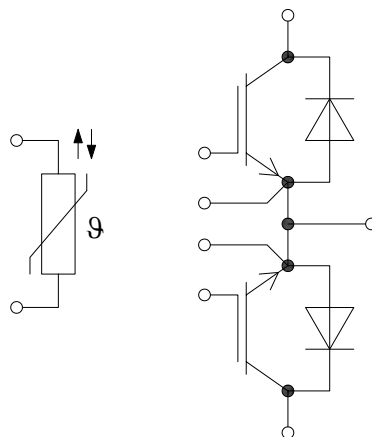

## Table of contents

	<b>Description</b> .....	1
	<b>Features</b> .....	1
	<b>Potential applications</b> .....	1
	<b>Product validation</b> .....	1
	<b>Table of contents</b> .....	2
<b>1</b>	<b>Package</b> .....	3
<b>2</b>	<b>IGBT, Inverter</b> .....	3
<b>3</b>	<b>Diode, Inverter</b> .....	5
<b>4</b>	<b>NTC-Thermistor</b> .....	6
<b>5</b>	<b>Characteristics diagrams</b> .....	7
<b>6</b>	<b>Circuit diagram</b> .....	12
<b>7</b>	<b>Package outlines</b> .....	13
<b>8</b>	<b>Module label code</b> .....	14
	<b>Revision history</b> .....	15
	<b>Disclaimer</b> .....	16

## 1 Package

**Table 1** Insulation coordination

Parameter	Symbol	Note or test condition	Values	Unit
Isolation test voltage	$V_{ISOL}$	RMS, $f = 50 \text{ Hz}$ , $t = 1 \text{ min}$	2.5	kV
Internal isolation		basic insulation (class 1, IEC 61140)	$Al_2O_3$	
Comparative tracking index	$CTI$		> 200	
Relative thermal index (electrical)	$RTI$	housing	140	°C

**Table 2** Characteristic values

Parameter	Symbol	Note or test condition	Values			Unit
			Min.	Typ.	Max.	
Stray inductance module	$L_{sCE}$			20		nH
Module lead resistance, terminals - chip	$R_{CC'+EE'}$	$T_H = 25 \text{ °C}$ , per switch		4.2		mΩ
Storage temperature	$T_{stg}$		-40		125	°C
Mounting force per clamp	$F$		20		50	N
Weight	$G$			24		g

*Note:* The current under continuous operation is limited to 25 A rms per connector pin.  
The electrical characterization was performed in NPC2 topology, which combines two FF75R12W1T7E\_B11 modules. It has to be considered, that the commutation in this configuration takes place between both modules.

## 2 IGBT, Inverter

**Table 3** Maximum rated values

Parameter	Symbol	Note or test condition		Values	Unit
Collector-emitter voltage	$V_{CES}$		$T_{vj} = 25 \text{ °C}$	1200	V
Implemented collector current	$I_{CN}$			75	A
Continuous DC collector current	$I_{CDC}$	$T_{vj \text{ max}} = 175 \text{ °C}$	$T_H = 65 \text{ °C}$	65	A
Repetitive peak collector current	$I_{CRM}$	$t_p$ limited by $T_{vj \text{ op}}$		150	A
Gate-emitter peak voltage	$V_{GES}$			±20	V

**Table 4** Characteristic values

Parameter	Symbol	Note or test condition		Values			Unit
				Min.	Typ.	Max.	
Collector-emitter saturation voltage	$V_{CE\ sat}$	$I_C = 75\ A, V_{GE} = 15\ V$	$T_{vj} = 25\ ^\circ C$		1.55	1.80	V
			$T_{vj} = 125\ ^\circ C$		1.69		
			$T_{vj} = 175\ ^\circ C$		1.77		
Gate threshold voltage	$V_{GETh}$	$I_C = 1.7\ mA, V_{CE} = V_{GE}, T_{vj} = 25\ ^\circ C$		5.15	5.80	6.45	V
Gate charge	$Q_G$	$V_{GE} = \pm 15\ V, V_{CC} = 600\ V$			1.25		$\mu C$
Internal gate resistor	$R_{Gint}$	$T_{vj} = 25\ ^\circ C$			2		$\Omega$
Input capacitance	$C_{ies}$	$f = 100\ kHz, T_{vj} = 25\ ^\circ C, V_{CE} = 25\ V, V_{GE} = 0\ V$			15.1		nF
Reverse transfer capacitance	$C_{res}$	$f = 100\ kHz, T_{vj} = 25\ ^\circ C, V_{CE} = 25\ V, V_{GE} = 0\ V$			0.053		nF
Collector-emitter cut-off current	$I_{CES}$	$V_{CE} = 1200\ V, V_{GE} = 0\ V$	$T_{vj} = 25\ ^\circ C$			0.0056	mA
Gate-emitter leakage current	$I_{GES}$	$V_{CE} = 0\ V, V_{GE} = 20\ V, T_{vj} = 25\ ^\circ C$				100	nA
Turn-on delay time (inductive load)	$t_{don}$	$I_C = 75\ A, V_{CC} = 600\ V, V_{GE} = \pm 15\ V, R_{Gon} = 0.68\ \Omega$	$T_{vj} = 25\ ^\circ C$		0.101		$\mu s$
			$T_{vj} = 125\ ^\circ C$		0.108		
			$T_{vj} = 175\ ^\circ C$		0.112		
Rise time (inductive load)	$t_r$	$I_C = 75\ A, V_{CC} = 600\ V, V_{GE} = \pm 15\ V, R_{Gon} = 0.68\ \Omega$	$T_{vj} = 25\ ^\circ C$		0.025		$\mu s$
			$T_{vj} = 125\ ^\circ C$		0.029		
			$T_{vj} = 175\ ^\circ C$		0.031		
Turn-off delay time (inductive load)	$t_{doff}$	$I_C = 75\ A, V_{CC} = 600\ V, V_{GE} = \pm 15\ V, R_{Goff} = 0.68\ \Omega$	$T_{vj} = 25\ ^\circ C$		0.256		$\mu s$
			$T_{vj} = 125\ ^\circ C$		0.327		
			$T_{vj} = 175\ ^\circ C$		0.360		
Fall time (inductive load)	$t_f$	$I_C = 75\ A, V_{CC} = 600\ V, V_{GE} = \pm 15\ V, R_{Goff} = 0.68\ \Omega$	$T_{vj} = 25\ ^\circ C$		0.086		$\mu s$
			$T_{vj} = 125\ ^\circ C$		0.165		
			$T_{vj} = 175\ ^\circ C$		0.215		
Turn-on energy loss per pulse	$E_{on}$	$I_C = 75\ A, V_{CC} = 600\ V, L_\sigma = 78\ nH, V_{GE} = \pm 15\ V, R_{Gon} = 0.68\ \Omega, di/dt = 1.76\ kA/\mu s (T_{vj} = 175\ ^\circ C)$	$T_{vj} = 25\ ^\circ C$		2.01		mJ
			$T_{vj} = 125\ ^\circ C$		3.14		
			$T_{vj} = 175\ ^\circ C$		4.17		
Turn-off energy loss per pulse	$E_{off}$	$I_C = 75\ A, V_{CC} = 600\ V, L_\sigma = 78\ nH, V_{GE} = \pm 15\ V, R_{Goff} = 0.68\ \Omega, dv/dt = 2360\ V/\mu s (T_{vj} = 175\ ^\circ C)$	$T_{vj} = 25\ ^\circ C$		4.91		mJ
			$T_{vj} = 125\ ^\circ C$		7.5		
			$T_{vj} = 175\ ^\circ C$		8.95		

(table continues...)

**Table 4** (continued) Characteristic values

Parameter	Symbol	Note or test condition	Values			Unit
			Min.	Typ.	Max.	
SC data	$I_{SC}$	$V_{GE} \leq 15 \text{ V}, V_{CC} = 800 \text{ V}, V_{CEmax} = V_{CES} - L_{SCE} \cdot di/dt$	$t_p \leq 8 \mu\text{s}, T_{vj} = 150 \text{ }^\circ\text{C}$		240	A
			$t_p \leq 7 \mu\text{s}, T_{vj} = 175 \text{ }^\circ\text{C}$		225	
Thermal resistance, junction to heat sink	$R_{thJH}$	per IGBT, $\lambda_{grease} = 1 \text{ W}/(\text{m}\cdot\text{K})$		0.813		K/W
Temperature under switching conditions	$T_{vj op}$		-40		175	$^\circ\text{C}$

Note:  $T_{vj op} > 150^\circ\text{C}$  is allowed for operation at overload conditions. For detailed specifications, please refer to AN 2018-14.

### 3 Diode, Inverter

**Table 5** Maximum rated values

Parameter	Symbol	Note or test condition	Values	Unit	
Repetitive peak reverse voltage	$V_{RRM}$	$T_{vj} = 25 \text{ }^\circ\text{C}$	1200	V	
Continuous DC forward current	$I_F$		75	A	
Repetitive peak forward current	$I_{FRM}$	$t_p = 1 \text{ ms}$	150	A	
$I^2t$ - value	$I^2t$	$t_p = 10 \text{ ms}, V_R = 0 \text{ V}$	$T_{vj} = 125 \text{ }^\circ\text{C}$	840	$\text{A}^2\text{s}$
			$T_{vj} = 175 \text{ }^\circ\text{C}$	710	

**Table 6** Characteristic values

Parameter	Symbol	Note or test condition	Values			Unit	
			Min.	Typ.	Max.		
Forward voltage	$V_F$	$I_F = 75 \text{ A}, V_{GE} = 0 \text{ V}$	$T_{vj} = 25 \text{ }^\circ\text{C}$		1.72	2.10	V
			$T_{vj} = 125 \text{ }^\circ\text{C}$		1.59		
			$T_{vj} = 175 \text{ }^\circ\text{C}$		1.52		
Peak reverse recovery current	$I_{RM}$	$V_{CC} = 600 \text{ V}, I_F = 75 \text{ A}, V_{GE} = -15 \text{ V}, -di_F/dt = 1.76 \text{ kA}/\mu\text{s} (T_{vj} = 175 \text{ }^\circ\text{C})$	$T_{vj} = 25 \text{ }^\circ\text{C}$		140		A
			$T_{vj} = 125 \text{ }^\circ\text{C}$		146		
			$T_{vj} = 175 \text{ }^\circ\text{C}$		152		

(table continues...)

**Table 6 (continued) Characteristic values**

Parameter	Symbol	Note or test condition	Values			Unit
			Min.	Typ.	Max.	
Recovered charge	$Q_r$	$V_{CC} = 600\text{ V}, I_F = 75\text{ A},$ $V_{GE} = -15\text{ V}, -di_F/dt = 1.76$ $\text{kA}/\mu\text{s} (T_{vj} = 175\text{ }^\circ\text{C})$	$T_{vj} = 25\text{ }^\circ\text{C}$		6.9	$\mu\text{C}$
			$T_{vj} = 125\text{ }^\circ\text{C}$		11.5	
			$T_{vj} = 175\text{ }^\circ\text{C}$		14.8	
Reverse recovery energy	$E_{rec}$	$V_{CC} = 600\text{ V}, I_F = 75\text{ A},$ $V_{GE} = -15\text{ V}, -di_F/dt = 1.76$ $\text{kA}/\mu\text{s} (T_{vj} = 175\text{ }^\circ\text{C})$	$T_{vj} = 25\text{ }^\circ\text{C}$		2.4	mJ
			$T_{vj} = 125\text{ }^\circ\text{C}$		4.67	
			$T_{vj} = 175\text{ }^\circ\text{C}$		5.98	
Thermal resistance, junction to heat sink	$R_{thJH}$	per diode, $\lambda_{grease} = 1\text{ W}/(\text{m}\cdot\text{K})$			1.12	K/W
Temperature under switching conditions	$T_{vj\text{ op}}$		-40		175	$^\circ\text{C}$

Note:  $T_{vj\text{ op}} > 150\text{ }^\circ\text{C}$  is allowed for operation at overload conditions. For detailed specifications, please refer to AN 2018-14.

## 4 NTC-Thermistor

**Table 7 Characteristic values**

Parameter	Symbol	Note or test condition	Values			Unit
			Min.	Typ.	Max.	
Rated resistance	$R_{25}$	$T_{NTC} = 25\text{ }^\circ\text{C}$		5		k $\Omega$
Deviation of $R_{100}$	$\Delta R/R$	$T_{NTC} = 100\text{ }^\circ\text{C}, R_{100} = 493\text{ }\Omega$	-5		5	%
Power dissipation	$P_{25}$	$T_{NTC} = 25\text{ }^\circ\text{C}$			20	mW
B-value	$B_{25/50}$	$R_2 = R_{25} \exp[B_{25/50}(1/T_2 - 1/(298,15\text{ K}))]$		3375		K
B-value	$B_{25/80}$	$R_2 = R_{25} \exp[B_{25/80}(1/T_2 - 1/(298,15\text{ K}))]$		3411		K
B-value	$B_{25/100}$	$R_2 = R_{25} \exp[B_{25/100}(1/T_2 - 1/(298,15\text{ K}))]$		3433		K

Note: For an analytical description of the NTC characteristics please refer to AN2009-10, chapter 4.

## 5 Characteristics diagrams

### Output characteristic (typical), IGBT, Inverter

$$I_C = f(V_{CE})$$

$$V_{GE} = 15 \text{ V}$$

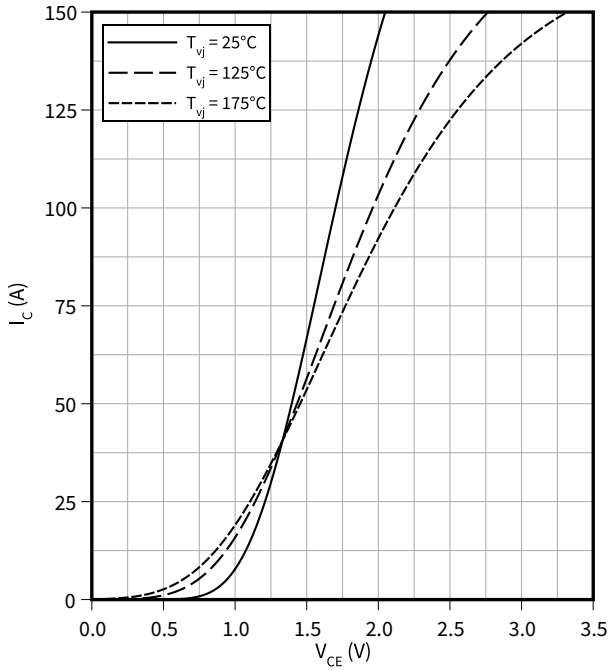

### Output characteristic field (typical), IGBT, Inverter

$$I_C = f(V_{CE})$$

$$T_{vj} = 175 \text{ }^\circ\text{C}$$

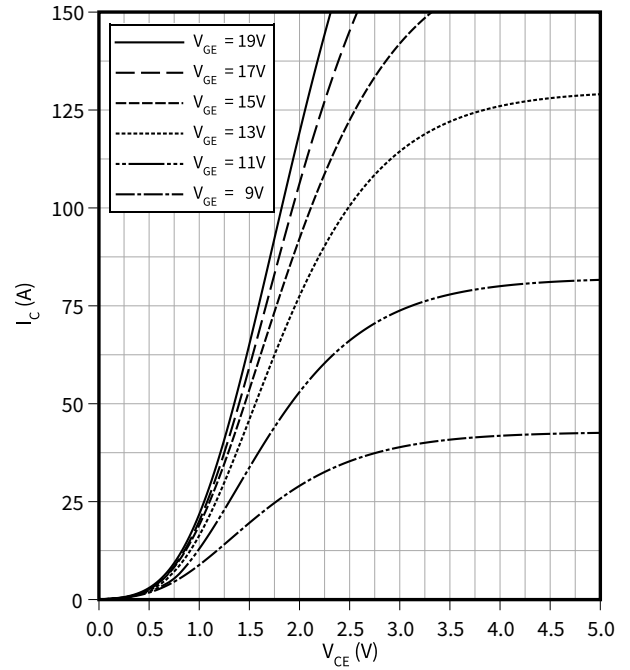

### Transfer characteristic (typical), IGBT, Inverter

$$I_C = f(V_{GE})$$

$$V_{CE} = 20 \text{ V}$$

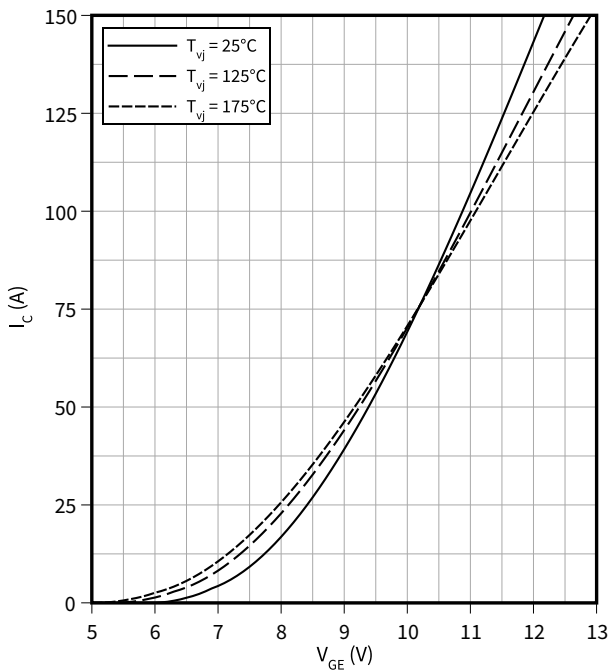

### Gate charge characteristic (typical), IGBT, Inverter

$$V_{GE} = f(Q_G)$$

$$I_C = 75 \text{ A}, T_{vj} = 25 \text{ }^\circ\text{C}$$

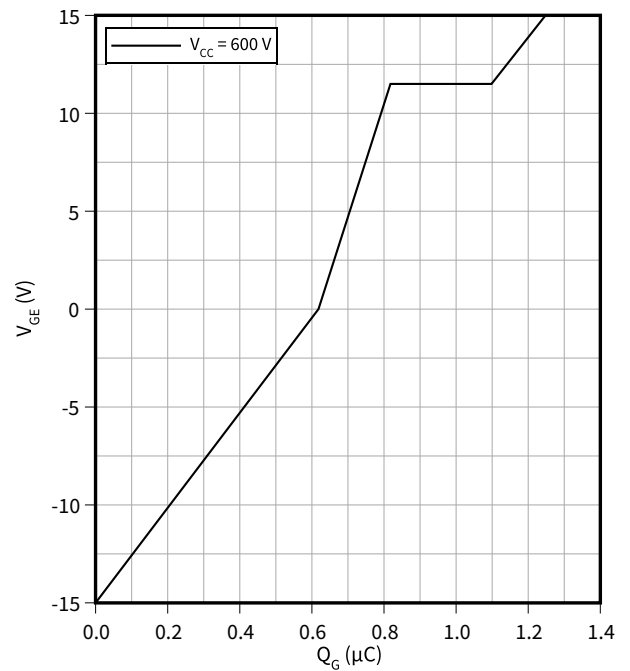

5 Characteristics diagrams

**Capacity characteristic (typical), IGBT, Inverter**

$C = f(V_{CE})$

$f = 100 \text{ kHz}, V_{GE} = 0 \text{ V}, T_{vj} = 25 \text{ }^\circ\text{C}$

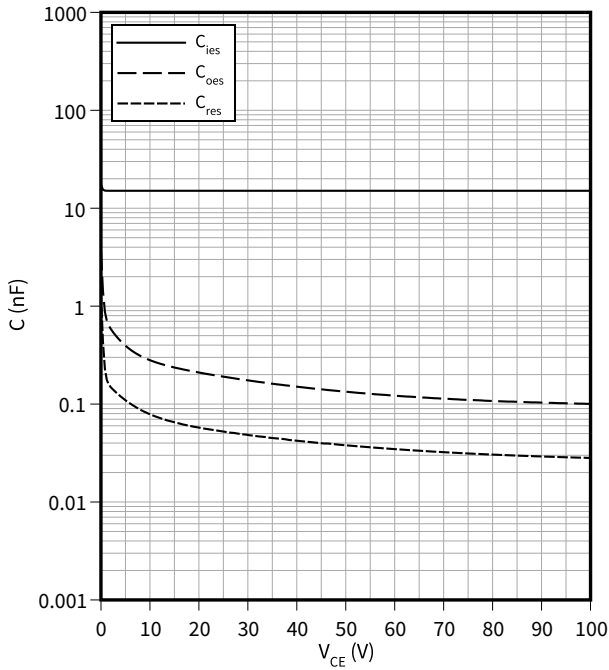

**Switching times (typical), IGBT, Inverter**

$t = f(I_C)$

$R_{Goff} = 0.68 \text{ } \Omega, R_{Gon} = 0.68 \text{ } \Omega, V_{GE} = \pm 15 \text{ V}, V_{CC} = 600 \text{ V}, T_{vj} = 175 \text{ }^\circ\text{C}$

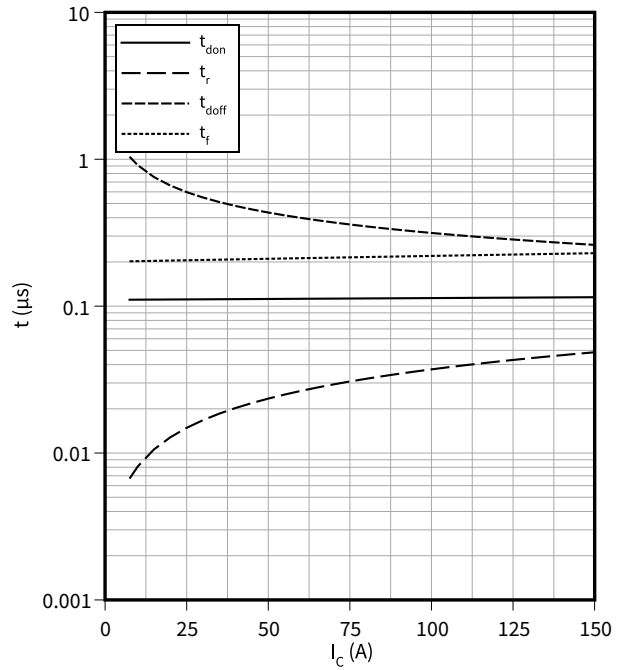

**Switching times (typical), IGBT, Inverter**

$t = f(R_G)$

$V_{GE} = \pm 15 \text{ V}, I_C = 75 \text{ A}, V_{CC} = 600 \text{ V}, T_{vj} = 175 \text{ }^\circ\text{C}$

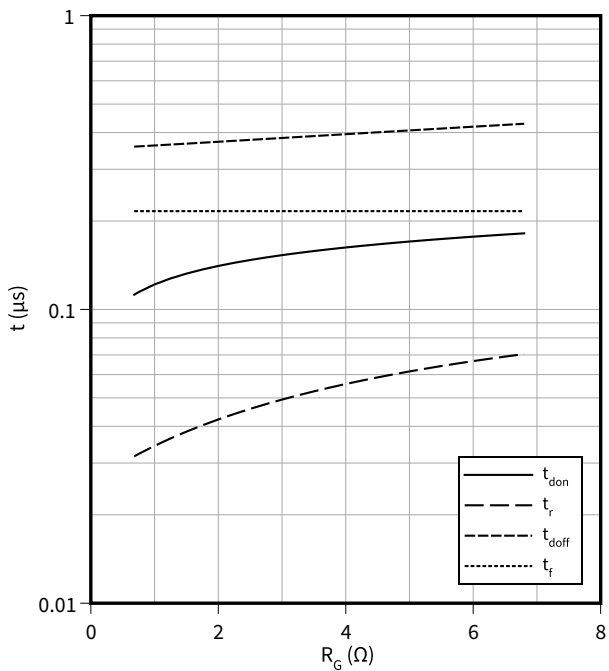

**Voltage slope (typical), IGBT, Inverter**

$dv/dt = f(R_G)$

$I_C = 75 \text{ A}, V_{CC} = 600 \text{ V}, V_{GE} = \pm 15 \text{ V}, T_{vj} = 25 \text{ }^\circ\text{C}$

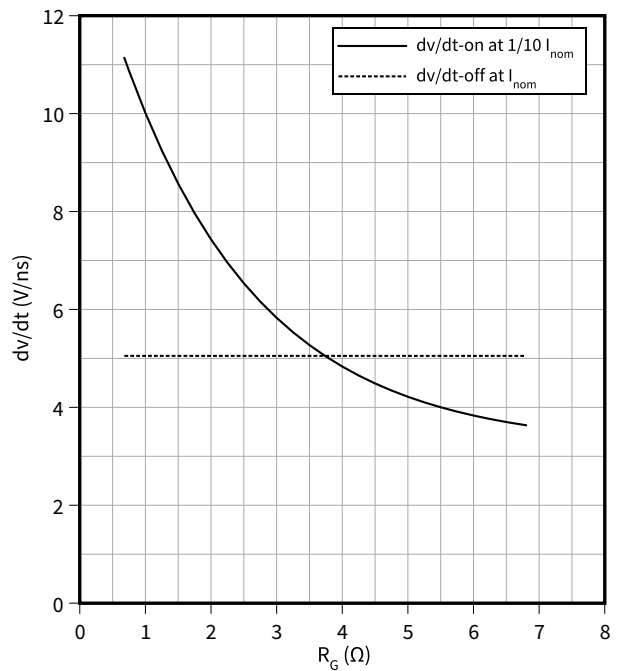



5 Characteristics diagrams

**Switching losses (typical), IGBT, Inverter**

$E = f(I_C)$

$R_{Goff} = 0.68 \Omega$ ,  $R_{Gon} = 0.68 \Omega$ ,  $V_{GE} = \pm 15 \text{ V}$ ,  $V_{CC} = 600 \text{ V}$

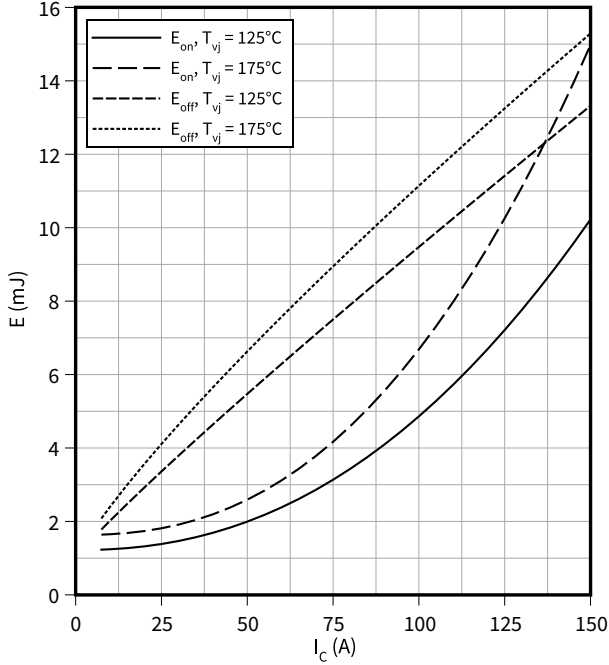

**Switching losses (typical), IGBT, Inverter**

$E = f(R_G)$

$V_{GE} = \pm 15 \text{ V}$ ,  $I_C = 75 \text{ A}$ ,  $V_{CC} = 600 \text{ V}$

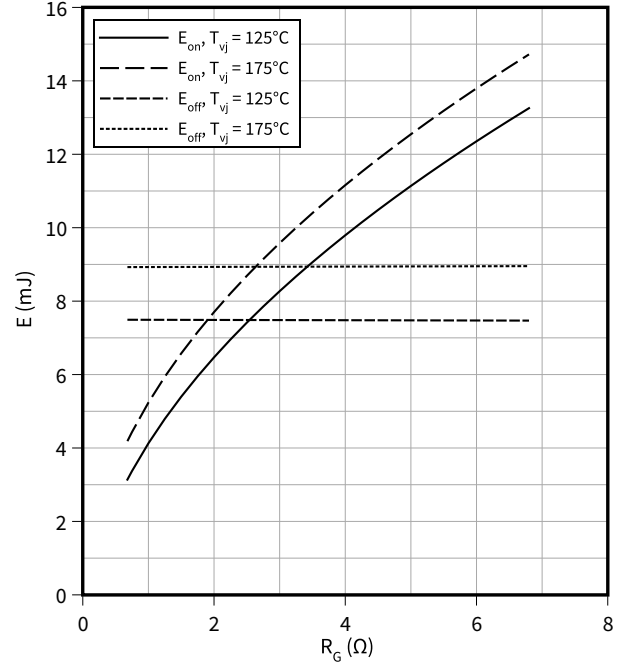

**Reverse bias safe operating area (RBSOA), IGBT, Inverter**

$I_C = f(V_{CE})$

$R_{Goff} = 0.68 \Omega$ ,  $V_{GE} = \pm 15 \text{ V}$ ,  $T_{vj} = 175 \text{ °C}$

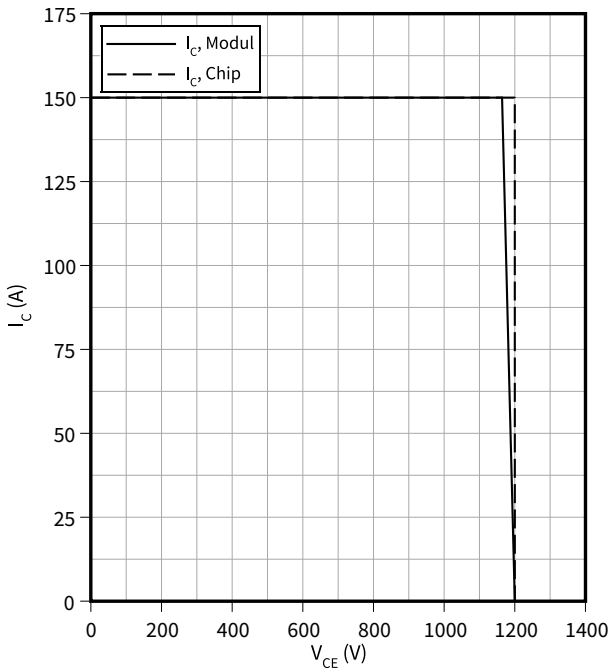

**Transient thermal impedance, IGBT, Inverter**

$Z_{th} = f(t)$

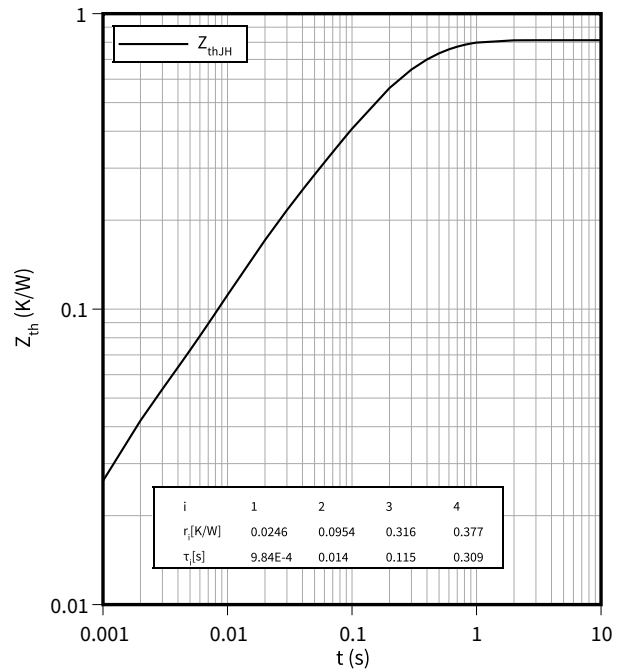

**Forward characteristic (typical), Diode, Inverter**

$I_F = f(V_F)$

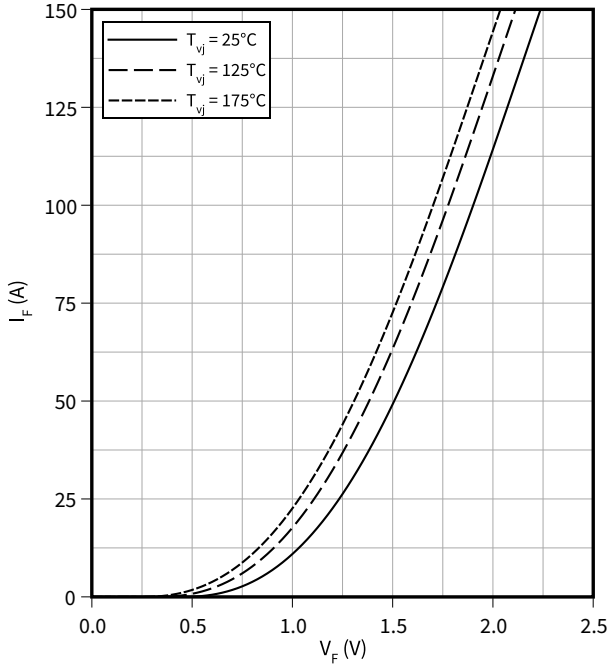

**Switching losses (typical), Diode, Inverter**

$E_{rec} = f(I_F)$

$R_{Gon} = 0.68 \Omega, V_{CC} = 600 \text{ V}$

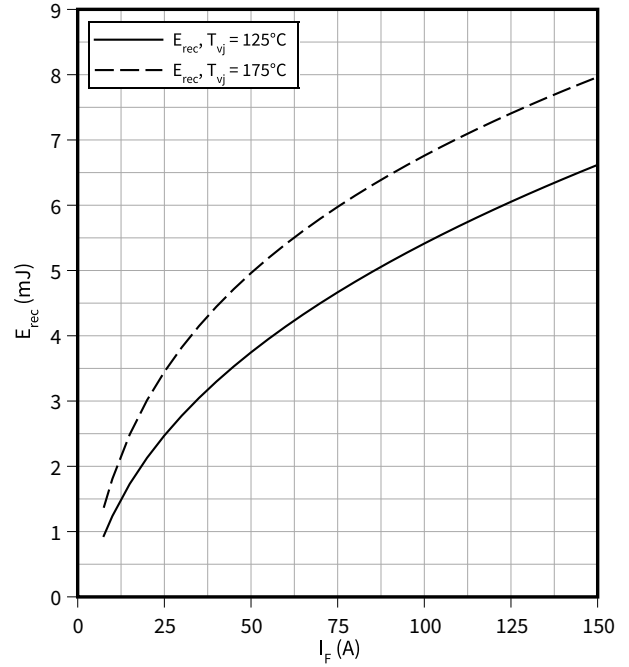

**Switching losses (typical), Diode, Inverter**

$E_{rec} = f(R_G)$

$I_F = 75 \text{ A}, V_{CC} = 600 \text{ V}$

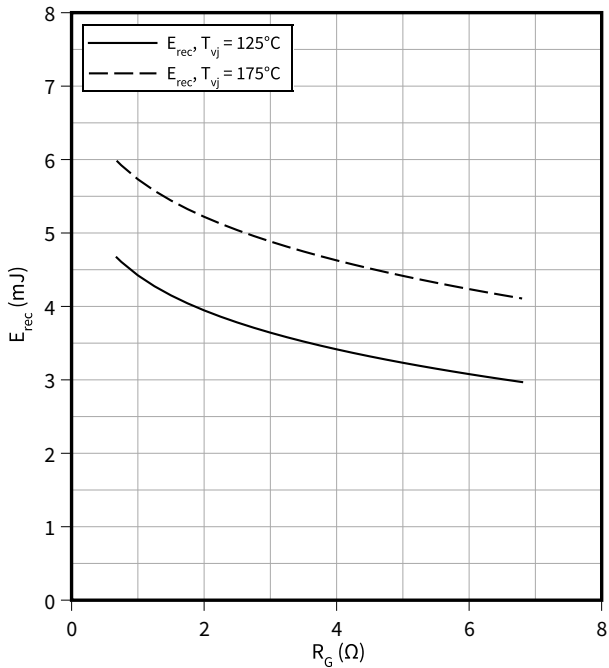

**Transient thermal impedance, Diode, Inverter**

$Z_{th} = f(t)$

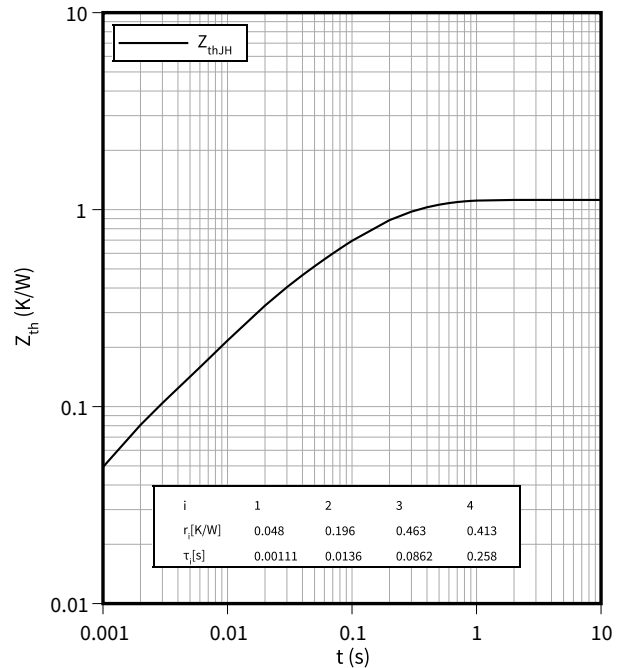

Temperature characteristic (typical), NTC-Thermistor

$$R = f(T_{NTC})$$

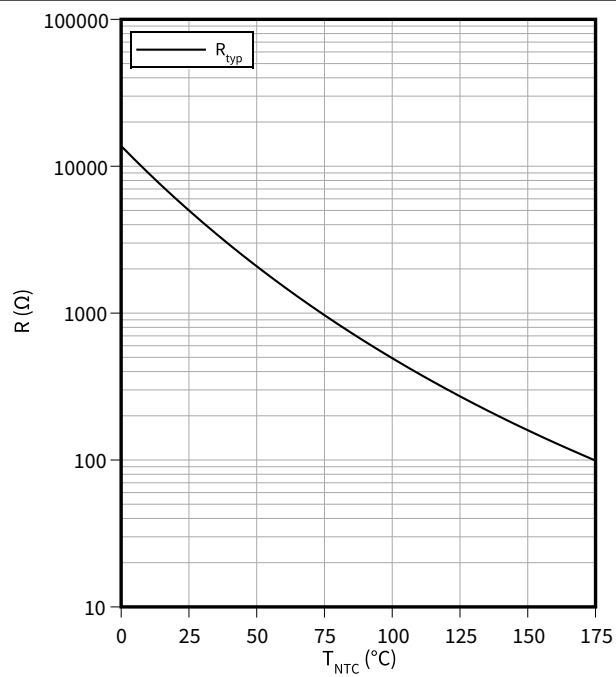

## 6 Circuit diagram

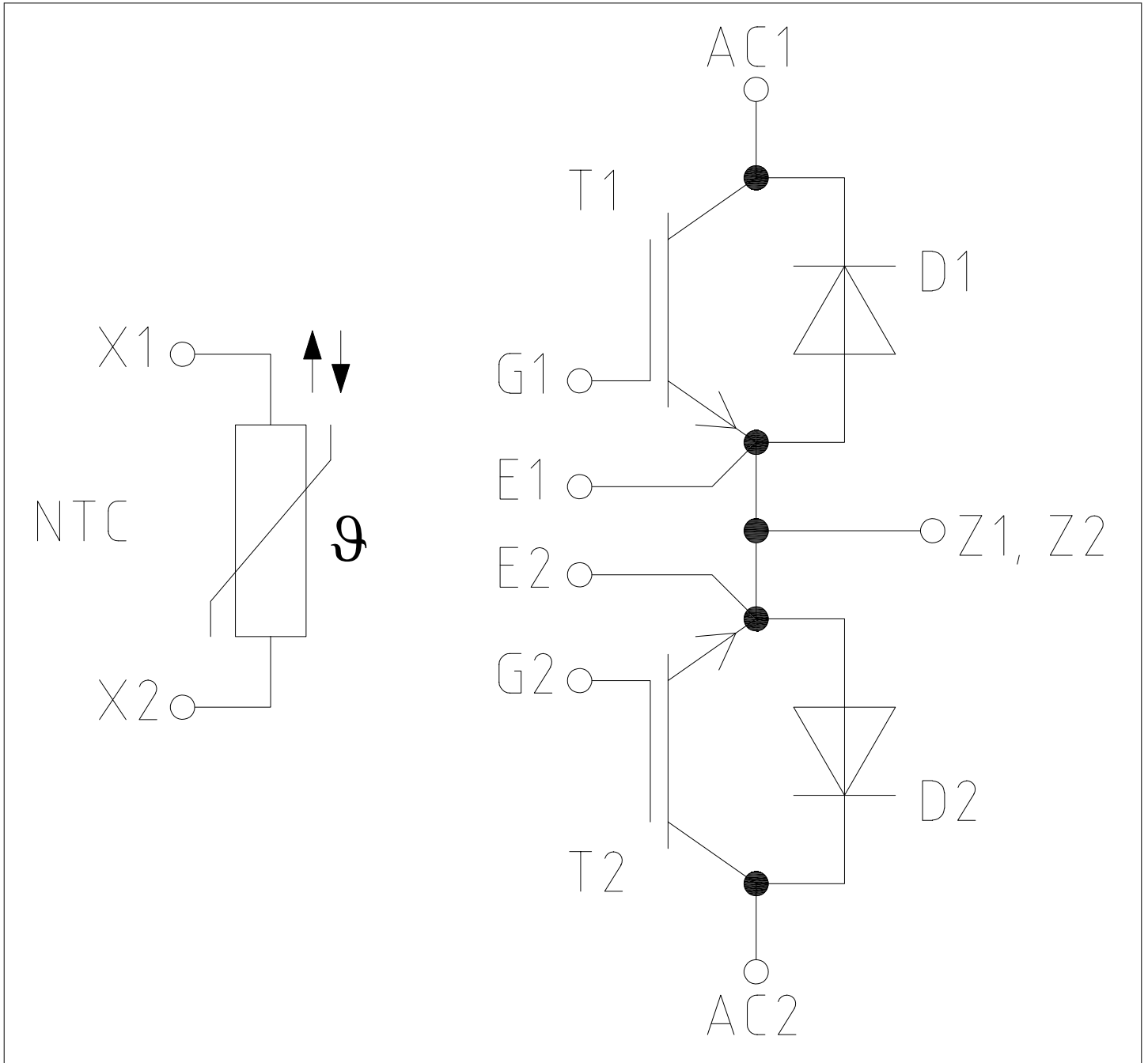
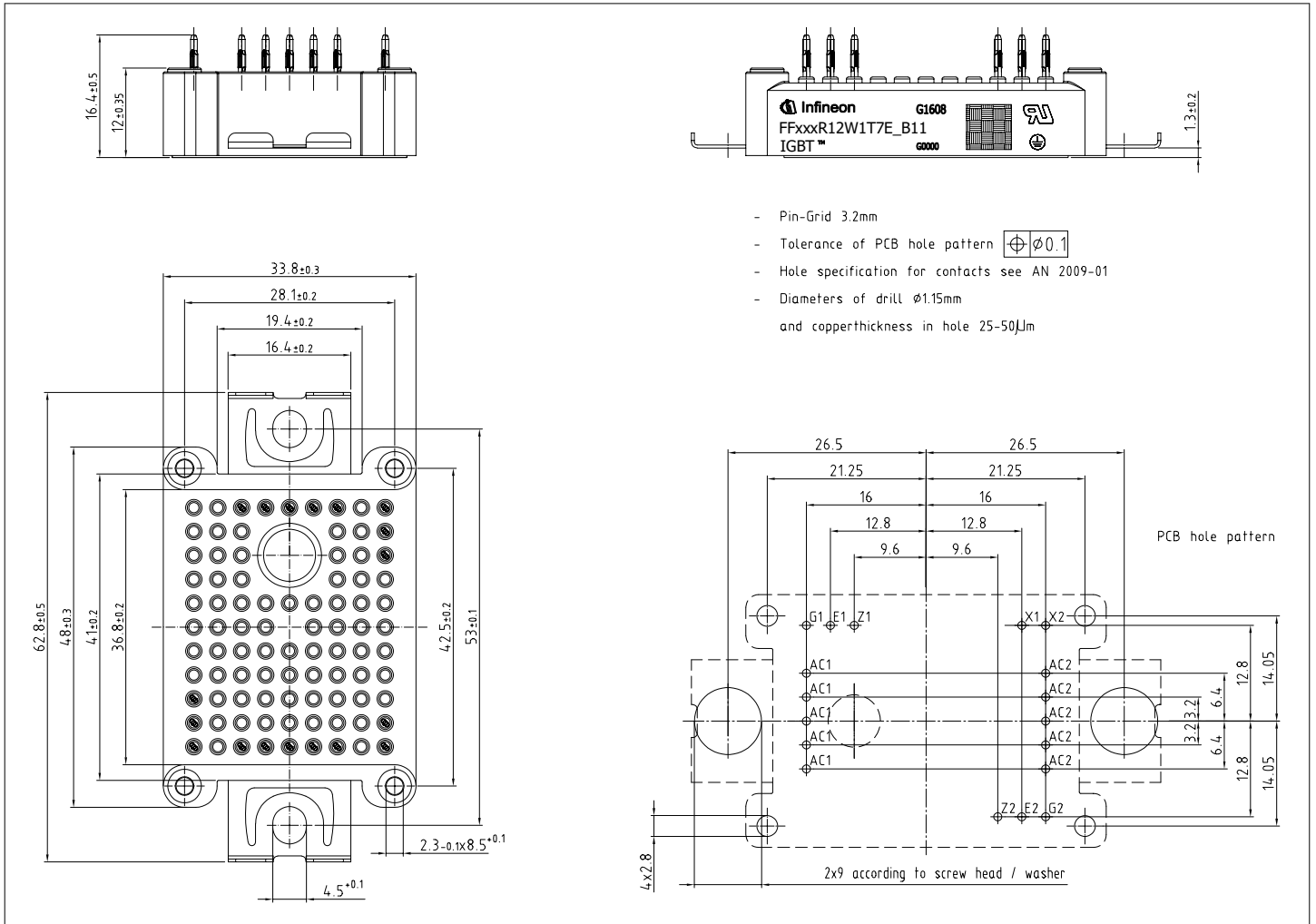



Figure 1

**7 Package outlines**



**Figure 2**

## 8 Module label code

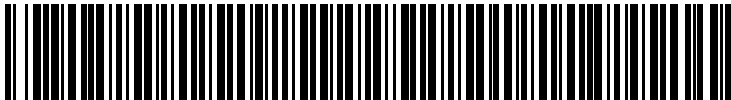
Module label code			
Code format	Data Matrix	Barcode Code128	
Encoding	ASCII text	Code Set A	
Symbol size	16x16	23 digits	
Standard	IEC24720 and IEC16022	IEC8859-1	
Code content	<i>Content</i> Module serial number Module material number Production order number Date code (production year) Date code (production week)	<i>Digit</i> 1 - 5 6 - 11 12 - 19 20 - 21 22 - 23	<i>Example</i> 71549 142846 55054991 15 30
Example	<div style="display: flex; justify-content: space-around; align-items: center;"> <div style="text-align: center;">               71549142846550549911530         </div> <div style="text-align: center;">               71549142846550549911530         </div> </div>		

**Figure 3**

## Revision history

Document revision	Date of release	Description of changes
0.10	2023-05-30	Initial version
1.00	2023-08-28	Final datasheet

## Trademarks

All referenced product or service names and trademarks are the property of their respective owners.

**Edition 2023-08-28**

**Published by**

**Infineon Technologies AG**

**81726 Munich, Germany**

**© 2023 Infineon Technologies AG**

**All Rights Reserved.**

**Do you have a question about any aspect of this document?**

**Email: [erratum@infineon.com](mailto:erratum@infineon.com)**

**Document reference**

**IFX-ABH271-002**

## Important notice

The information given in this document shall in no event be regarded as a guarantee of conditions or characteristics ("Beschaffheitsgarantie").

With respect to any examples, hints or any typical values stated herein and/or any information regarding the application of the product, Infineon Technologies hereby disclaims any and all warranties and liabilities of any kind, including without limitation warranties of non-infringement of intellectual property rights of any third party.

In addition, any information given in this document is subject to customer's compliance with its obligations stated in this document and any applicable legal requirements, norms and standards concerning customer's products and any use of the product of Infineon Technologies in customer's applications.

The data contained in this document is exclusively intended for technically trained staff. It is the responsibility of customer's technical departments to evaluate the suitability of the product for the intended application and the completeness of the product information given in this document with respect to such application.

## Warnings

Due to technical requirements products may contain dangerous substances. For information on the types in question please contact your nearest Infineon Technologies office.

Except as otherwise explicitly approved by Infineon Technologies in a written document signed by authorized representatives of Infineon Technologies, Infineon Technologies' products may not be used in any applications where a failure of the product or any consequences of the use thereof can reasonably be expected to result in personal injury.