

E9XA

Automotive surface mount crystal resonator MHz



Photo is representative

Product features

- 0806 (2016 metric) package
- Moisture sensitivity level (MSL): 1
- AEC-Q200
- Frequency range 16 MHz to 50 MHz
- Variety of frequency tolerance and stability options

Applications

- Tire-pressure monitoring system (TPMS)
- Remote keyless entry (RKE)
- Front lighting system
- ADAS
- Camera/radar system
- In-vehicle infotainment (IVI)
- Car audio
- Battery management systems (BMS)

Environmental compliance and general specifications

- Operating temperature range: -40 °C to +125 °C
- Storage temperature range (component): -40 °C to +125 °C



Part number system

E	9	X	260	08	1	Z	A1
	Size code	Product category	Frequency	Load capacitance	Frequency tolerance	Frequency stability	Internal code
E = Eaton	9 = 2016 metric, 0806 imperial	X = crystal	260 = 26 MHz	08 = 8 pF 10 = 10 pF 12 = 12 pF	1 = ±10 ppm 7 = ±15 ppm 2 = ±20 ppm 4 = ±30 ppm 5 = ±50 ppm	Z = ±50 ppm Q = ±100 ppm	(A1 - A9, AA - AZ without I&O) for automotive

Electrical specifications

Items	Parameters
Frequency range	16 MHz to 50 MHz
Oscillation mode	Fundamental
Frequency tolerance at +25 °C	±10, ±15, ±20, ±30, ±50 ppm
Frequency stability vs. operating temperature range	See table below
Equivalent series resistance	See table below
Drive level	10, 100, 200 µW or specify
Insulation resistance	500 MΩ minimum at 100 Vdc
Load capacitance	8, 10, 12 pF or specify
Shunt capacitance (C0)	3 pF maximum or specify
Aging at +25 °C	±3 ppm (first year)

Frequency stability vs. operating temperature range table

ppm	±50	±100
Operating temperature -40 °C to +125 °C	x	x

Equivalent series resistance table

Frequency (MHz)	ESR (Ω) maximum	Oscillation mode
16 ≤ f < 20	120	Fundamental
20 ≤ f < 32	80	
32 ≤ f ≤ 50	50	

Construction

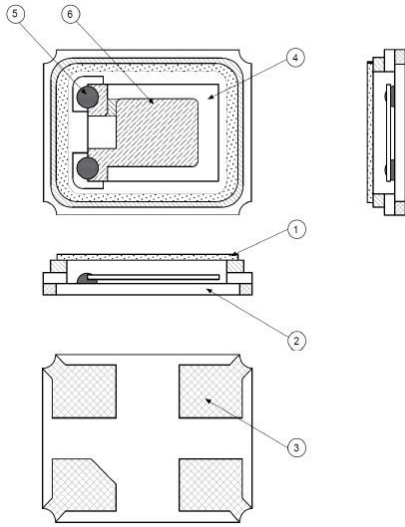

Item number	Component	Description
1	Cap (lid)	Kovar (Fe-Ni-Co)
2	Base (package)	Almina Ceramic (Al ₂ O ₃)
3	Pad (package)	Ni + Au
4	Crystal blank	SiO ₂
5	Conductive adhesive	Ag
6	Electrode	Cr + Au

Dimensions -mm

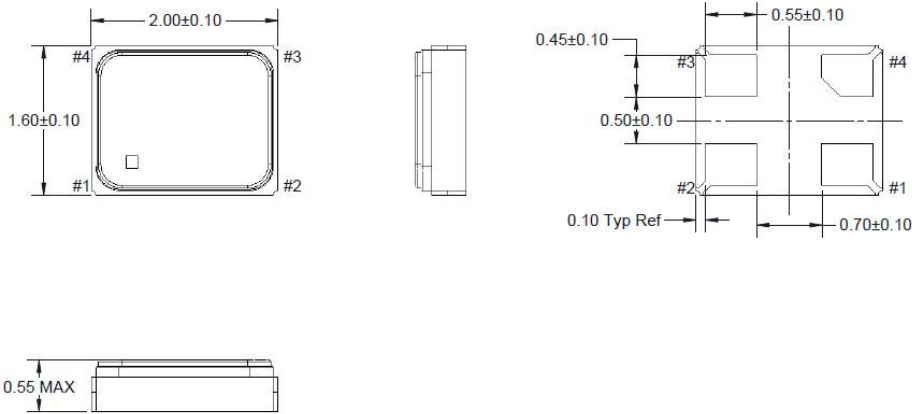

Pad layout -mm

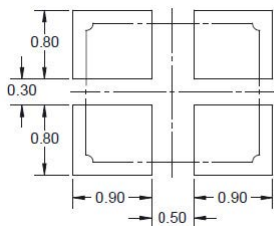

Function diagram

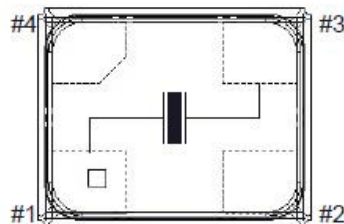

Pad	Function
1	In / out
2	Ground
3	Out / in
4	Ground

Tolerance unless otherwise specified: ±0.1 mm

Part marking

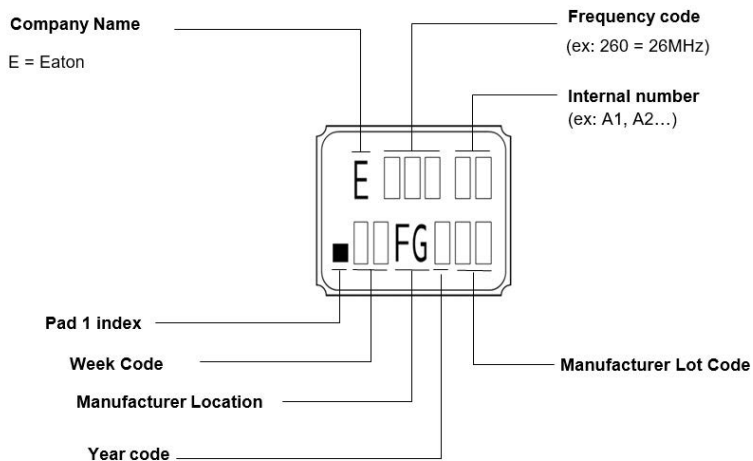

Packaging information - mm

3,000 parts on a 7 inch tape and reel (Drawing not to scale)

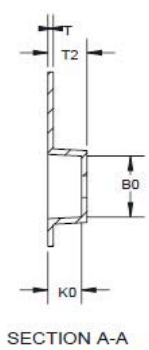
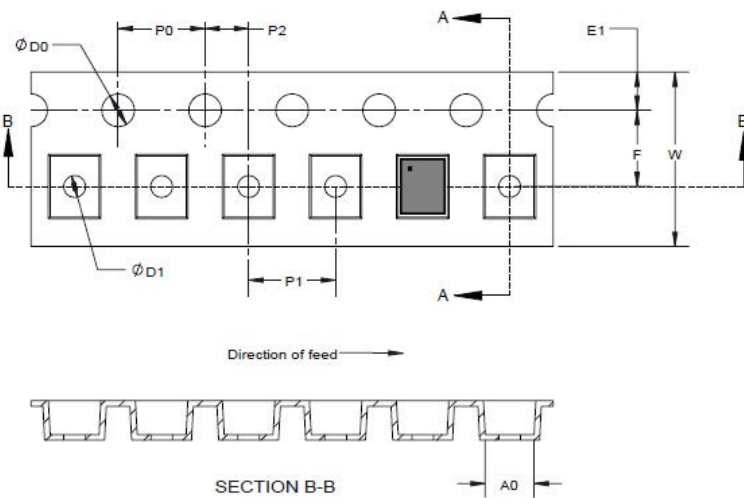

Dimension	Millimeter
W	8.00 ± 0.30
F	3.50 ± 0.05
E1	1.75 ± 0.10
P0	4.00 ± 0.10
P1	4.00 ± 0.10
P2	2.00 ± 0.05
D0	1.55 ± 0.05
D1	1.00 minimum
A0	1.90 ± 0.10
B0	2.30 ± 0.10
K0	0.65 ± 0.10
T	0.25 ± 0.05
T2	1.15 maximum

Solder reflow profile



Table 1 - Standard SnPb solder (T_C)

Package thickness	Volume mm ³ <350	Volume mm ³ ≥350
<2.5 mm	235 °C	220 °C
≥2.5 mm	220 °C	220 °C

Table 2 - Lead (Pb) free solder (T_C)

Package thickness	Volume mm ³ <350	Volume mm ³ 350 - 2000	Volume mm ³ >2000
<1.6 mm	260 °C	260 °C	260 °C
1.6 – 2.5 mm	260 °C	250 °C	245 °C
>2.5 mm	250 °C	245 °C	245 °C

Reference J-STD-020

Profile feature	Standard SnPb solder	Lead (Pb) free solder
Preheat and soak	<ul style="list-style-type: none"> Temperature min. (T_{smin}) Temperature max. (T_{smax}) Time (T_{smin} to T_{smax}) (t_s) 	<ul style="list-style-type: none"> 100 °C 150 °C 60-120 seconds
Ramp up rate T _L to T _p	3 °C/ second max.	3 °C/ second max.
Liquidous temperature (T _L)	183 °C	217 °C
Time (t _L) maintained above T _L	60-150 seconds	60-150 seconds
Peak package body temperature (T _p)*	Table 1	Table 2
Time (t _p)* within 5 °C of the specified classification temperature (T _C)	20 seconds*	30 seconds*
Ramp-down rate (T _p to T _L)	6 °C/ second max.	6 °C/ second max.
Time 25 °C to peak temperature	6 minutes max.	8 minutes max.

* Tolerance for peak profile temperature (T_p) is defined as a supplier minimum and a user maximum.

Manual solder

+350 °C maximum, 4 seconds maximum by soldering iron, 2 times maximum, generally manual, hand soldering is not recommended

Life Support Policy: Eaton does not authorize the use of any of its products for use in life support devices or systems without the express written approval of an officer of the Company. Life support systems are devices which support or sustain life, and whose failure to perform, when properly used in accordance with instructions for use provided in the labeling, can be reasonably expected to result in significant injury to the user.

Eaton reserves the right, without notice, to change design or construction of any products and to discontinue or limit distribution of any products. Eaton also reserves the right to change or update, without notice, any technical information contained in this bulletin.

Eaton
Electronics Division
1000 Eaton Boulevard
Cleveland, OH 44122
United States
Eaton.com/electronics

© 2023 Eaton
All Rights Reserved
Printed in USA
Publication No. ELX1391 BU-ELX22259
December 2023

Eaton is a registered trademark.
All other trademarks are property of their respective owners.

Follow us on social media to get the latest product and support information.

