

Thermoelectric Cooler Assembly Direct To Air

multicomp PRO

**RoHS
Compliant**

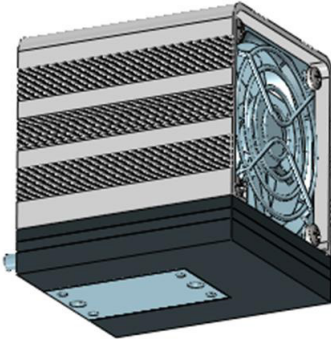

Description

Adaptive thermoelectric cooling assemblies come in direct to air, air to air and liquid to air variations comprising thermoelectric cooler module/s, heat exchangers, fan/s and thermal interfaces which are optimised for effective heat transfer.

European Thermodynamics are specialists in thermal management and thermoelectrics, developing the high performance thermoelectrics products and materials of the future. The Direct-to-Air Thermoelectric cooling assemblies are compact devices that can be used to cool down objects through conduction. The objects to be cooled down are mounted onto the metallic plate at the 'cold side' of the assembly from where heat is pumped by Peltier thermoelectric modules and dissipated to the environment through the use of bespoke heatsinks and highly efficient DC fans at the hot side of the assemblies. The thermoelectric modules, whose reliability and maintenance-free operation has been proven by the years, are carefully selected for each assembly to ensure the best cooling performance and minimise power consumption.

Features

- Easy to install
- High reliability
- Low noise
- Precise temperature control

Applications

- Analytical & Lab instruments
- Liquid cooling
- Fluid analysis

Specification

Maximum cooling power	: 14W
Nominal voltage	: 12V
Maximum voltage	: 15V
Maximum current	: 4A
Power input	: 36W
Operating temperature	: -10°C to +50°C
Weight	: 0.39kg
Performance tolerance	: 10%
L10 of fans at 40°C	: Hot side:70121hrs

Performance graph

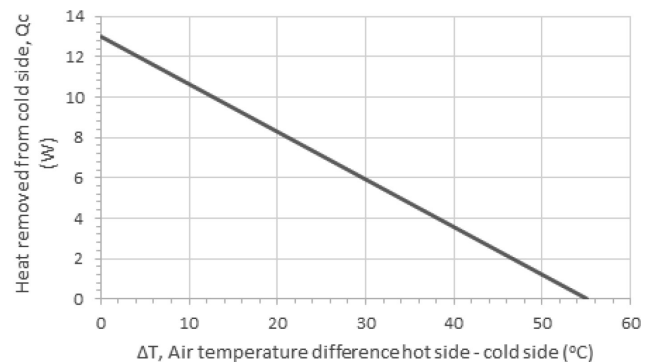

Newark.com/multicomp-pro
Farnell.com/multicomp-pro
sg.element14.com/b/multicomp-pro

multicomp PRO

Thermoelectric Cooler Assembly Direct To Air



Diagram

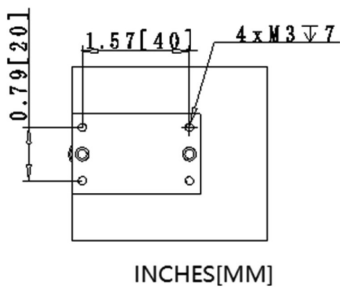
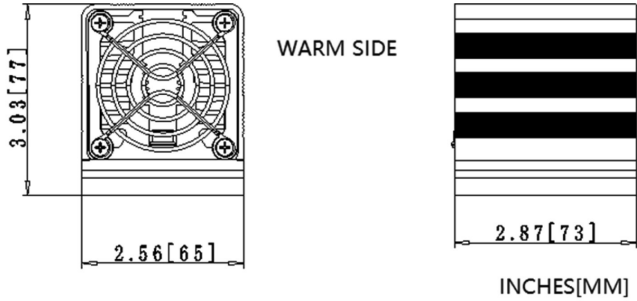

Part Number Table

Description	Part Number
Thermoelectric Cooler, Adaptive Valve, Direct To Air, 14W, 12V D	MP-DT-AR-014-12-ADV

Important Notice : This data sheet and its contents (the "Information") belong to the members of the AVNET group of companies (the "Group") or are licensed to it. No licence is granted for the use of it other than for information purposes in connection with the products to which it relates. No licence of any intellectual property rights is granted. The Information is subject to change without notice and replaces all data sheets previously supplied. The Information supplied is believed to be accurate but the Group assumes no responsibility for its accuracy or completeness, any error in or omission from it or for any use made of it. Users of this data sheet should check for themselves the Information and the suitability of the products for their purpose and not make any assumptions based on information included or omitted. Liability for loss or damage resulting from any reliance on the Information or use of it (including liability resulting from negligence or where the Group was aware of the possibility of such loss or damage arising) is excluded. This will not operate to limit or restrict the Group's liability for death or personal injury resulting from its negligence. Multicomp Pro is the registered trademark of Premier Farnell Limited 2019.

Newark.com/multicomp-pro
Farnell.com/multicomp-pro
sg.element14.com/b/multicomp-pro

