

IP67 USB Type-C Connector

Harsh Environment Connector Series

Stewart Connector introduces IP67 USB Type-C Connectors. These IP67 rated USB Type-C connectors support USB 3.1 Gen 1 and Gen 2 to meet 10Gbps. USB Type-C connectors allow for a reversible mating interface, providing an easy and reliable mating of the plug to jack in any plug direction. USB Type-C connectors are growing in popularity in new and emerging products, introducing the need for a connector that can support high-speed transmissions of audio and video signal output in harsh environments.

Features & Benefits

- Reflow solder compatible
- Current carrying capacity of 5A
- Support USB 3.1 and are backwards compatible with USB 2.0
- SS-52400-004:
 - Mid-surface mount design feature
 - Packaged in tape and reel for pick and place operations
- SS-52400-007:
 - Bulkhead Mount
 - Packaged in trays for pick and place operations

Applications

- Medical devices
- Industrial environments
- Military communication
- Renewable energy industry
- Rugged computing equipment

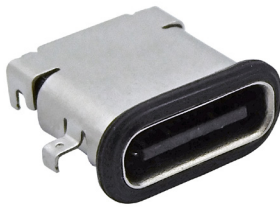

Part Number	IP Rating	Operating Temperature	Performance Speed	PCB Height
SS-52400-004	IP67	-40°C – 80°C	USB 3.1	0.012 in (0.30 mm)
SS-52400-007	IP67	-30°C – 80°C	USB 3.2	0.012 in (0.30 mm)

SS-52400-004

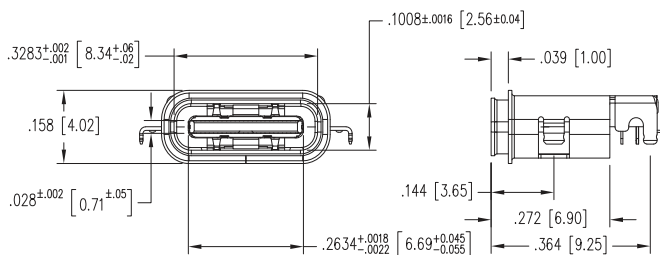

SS-52400-007

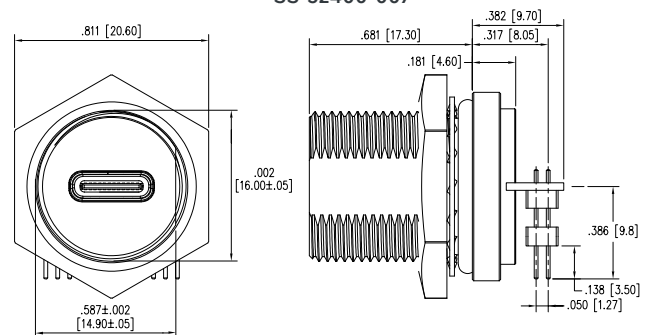

+1 717.235.7512
techhelp@belf.com

belfuse.com/stewart-connector

Specification subject to change without notice.

ds-Stewart-IP67-USB-Type-C-Connector-12-2024-1.0R