

groovRIO® UNIVERSAL EDGE I/O

Features

- > Powered by either Power over Ethernet (PoE) **or** 10-32 VDC power supply
- > 10 channels of software-configurable inputs and outputs
- > Analog I/O, temperature, discrete I/O, and mechanical relays
- > Two switched Gigabit Ethernet network interfaces for wired networks; supports star or daisy-chain topologies
- > CODESYS runtime engine to run control programs in any IEC 61131-3 compliant language (license required)
- > Embedded web-based applications: *groov*® Manage, Node-RED, and MQTT; GRV-R7-MM2001-10 includes Ignition Edge®
- > USB port for adding devices like Wi-Fi adapter or USB memory drive (user supplied)
- > Built-in security with encryption and authentication



GRV-R7-MM1001-10, GRV-R7-MM2001-10

DESCRIPTION

Opto 22's *groov* RIO—remote Ethernet I/O for industrial internet of things (IIoT) and automation applications—solves two main problems with most remote I/O today:

- First, specifying all the required components (rack, power supply, bus coupler, module types, and more) is time-consuming, difficult, and requires significant domain expertise.
- Second, communicating data among field devices, control systems, company software, and cloud services is complex and costly, requiring PLCs, programming, and middleware.

groov RIO revolutionizes remote I/O by solving both problems.

- **One module.** A single module includes built-in, software-configurable I/O; an I/O processor; power over Ethernet; robust cybersecurity features; and mounting without the need for a rack or chassis—in a compact industrial package.
- **Built-in data and control processing.** Web-based configuration, Node-RED software, CODESYS runtime engine for IEC 61131-3 applications, and available SSH access for developing your own custom applications that run on the module.
- **Multiple communication options.** Data communication methods and protocols, including MQTT, Sparkplug, OPC UA, REST API, and Modbus to address any IIoT or automation application.

This data sheet covers *groov* RIO universal I/O modules. For a *groov* RIO module designed specifically for energy monitoring (*groov* RIO EMU), see the [groov RIO Energy Monitoring Unit Data Sheet](#).

groov RIO is Edge I/O—and More

These features make *groov* RIO an advanced kind of I/O product: *edge I/O*. Edge I/O does not require an external PLC, PAC, or industrial PC, but is designed as an intelligent, distributed I/O device to meet the needs of IIoT projects, especially those that require data acquisition or communications.

If you need control capability, the on-board CODESYS runtime engine fully supports IEC 61131-3 application programs written in the programming language of your choice: structured text, ladder logic diagram, functional block diagram, and continuous or sequential function chart. Licensing for the CODESYS runtime engine is available separately (see [GROOV-LIC-CRE-RIO](#) or below).

Part Number

Part	Description
GRV-R7-MM1001-10	<i>groov</i> RIO universal edge I/O; 8 multifunction, 2 form C electromechanical relay output channels
GRV-R7-MM2001-10	<i>groov</i> RIO universal edge I/O; 8 multifunction, 2 form C electromechanical relay output channels; Ignition Edge
GROOV-LIC-EDGE8	Activation key for Ignition Edge software, version 8.1 (only for GRV-R7-MM2001-10)
GROOV-LIC-SHELL	Activation key for secure shell access to Linux operating system
GROOV-LIC-CRE-RIO	Activation key for CODESYS Runtime Engine software on <i>groov</i> RIO modules

With *groov* RIO, you can:

- Place the module almost anywhere for remote I/O and data communications. *groov* RIO operates through a wide range of operating temperatures (-20 to 70 °C), is UL/cUL listed, and complies with the ATEX, Low Voltage, and EMC CE directives and UKCA directives.
- Supply power to *groov* RIO through one of the following:
 - The ETH1 network interface connected to a Power over Ethernet Switch and cable (802.3af PoE Class 0), **or**
 - the power supply terminals connected to a 10–32 V DC power supply.
- Connect the two switched Gigabit Ethernet network interfaces in a daisy-chain configuration or in a standard star configuration. Both interfaces use a single IP address.
- Connect additional devices like a Wi-Fi adapter, a USB memory stick (up to 32 GB), or a USB-to-serial adapter via the *groov* RIO's USB port (additional devices are user supplied).
- Simplify field connections using the 26-pin removable field I/O termination connector with spring clamp wire retention.
- Easily see the status of power, network, and I/O activity on the module's LEDs.
- Use embedded software to quickly set up data communications between field devices and on-premises or cloud-based systems and software.
- Run a control program you build using the CODESYS Development System—right there on your remote I/O.

groov RIO as Edge I/O

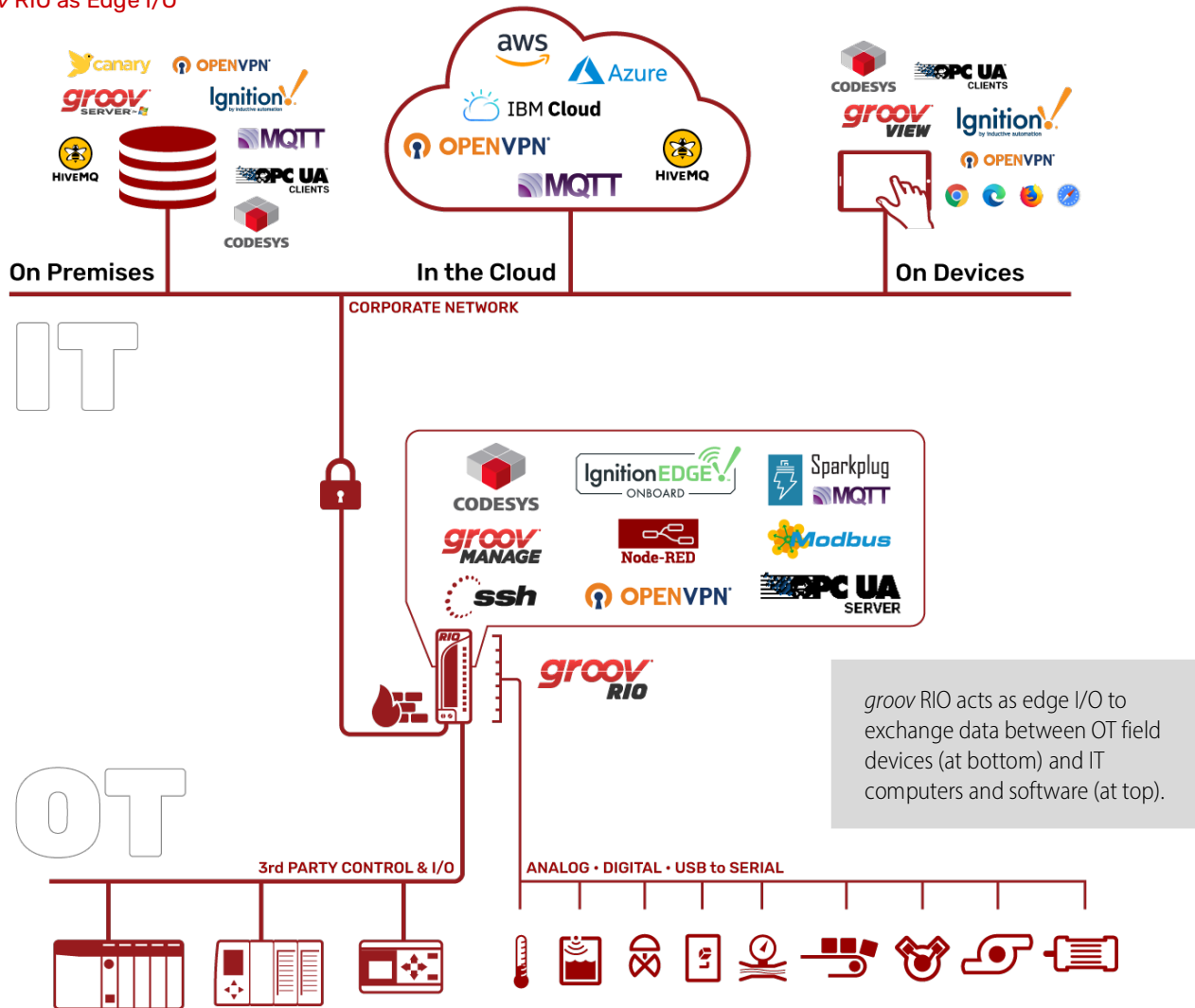

Get Up and Running Faster

groov RIO's single part number gives you everything you need for edge I/O, plus options. With Power over Ethernet, you can avoid the extra time and expense of routing power or adding a power supply dedicated to *groov* RIO. Just run a Category 5e or 6 Ethernet cable from a PoE-supplying network switch to ETH1—bringing power and networking over a single cable.

After you turn on your *groov* RIO, open a web browser on a computer or mobile device to connect to your RIO's IP address or hostname.

groov Manage—a web app that gives you command center-like access to your *groov* RIO—opens so you can configure, troubleshoot, and commission built-in I/O, networking, and security.

Configure a Mix of I/O Channels

The GRV-R7-MM1001-10 and GRV-R7-MM2001-10 are 10-channel universal edge I/O modules supporting thousands of unique field I/O combinations. (How is this possible? Take a look at the wiring diagram on [page 19](#) to see all the available features and input/output configurations or visit info.opto22.com/thousands.)

Through *groov* Manage, you can select a channel, configure its I/O signal, select any feature—such as counting, latching, clamping, and more—supported by the selected channel, and then save your configuration.

Exchange/Send Data Wherever You Like

groov RIO supports both OT and IT protocols and tools, making it easier to safely move data among field devices and computer networks, in some cases without requiring a PLC or middleware. Choose the method that works best for you:

Modbus TCP/IP master—*groov* RIO is a Modbus TCP slave out of the box. Use your favorite Modbus TCP master device or software to poll RIO's I/O channels. A Modbus TCP calculator is built into *groov* RIO's *groov* Manage application, helping you quickly find the Modbus Unit ID and register for a memory map area.

C++ or .NET and free SDKs—With your favorite development tool and our free SDKs, you can programmatically access I/O values on a *groov* RIO by accessing the OptoMMP memory map locations of each channel. An OptoMMP calculator is built into *groov* RIO's *groov* Manage, making it simple to identify the MMP addresses of I/O channels and their features.

HTTP/S, JSON, and REST APIs—The developer community has embraced REST APIs as a method of accessing I/O with HTTP/S and JSON. Opto 22 provides REST APIs for *groov* Manage, which you use to access the I/O values on a *groov* RIO module. A Swagger API document is built into *groov* RIO to quickly access REST API calls and evaluate responses.

MQTT broker/server—An efficient and robust publish/subscribe protocol, MQTT is an ideal method of exchanging data for industrial internet of things (IIoT) applications. *groov* RIO has support for MQTT built in, requiring only a simple configuration to publish I/O data and subscribe to commands as Sparkplug-B or string payloads.

Node-RED—Create a data flow with the built-in Node-RED editor and runtime to send data to cloud services, databases, other I/O channels, and APIs through pre-built nodes. Even develop simple user interfaces (UIs) with Node-RED UI nodes and serve them directly from *groov* RIO to any mobile or web-based device.

groov RIO in a Control Program or SCADA

In addition to its use as autonomous edge I/O, *groov* RIO can also be used to expand the scope of existing control programs or industrial applications. You can add *groov* RIO modules to monitor, control, and collect data from field devices:

- **In a PAC Control™ strategy**—With PAC Project™ Basic or Professional Software Suite, add a *groov* RIO as an I/O unit, configure your I/O points, then download your strategy to a:
 - *groov* EPIC® processor running firmware version 2.0.0 or higher
 - SNAP PAC controller or SoftPAC running PAC Controller firmware 10.3 or higher (also requires PAC Project 10.3 or higher)
- **In a CODESYS® application**—Download and install the Opto 22 Library Package for CODESYS Development System, version 2.0.0.0 or later. If you plan to use *groov* RIO as a PLC, see below. Update your application and you'll be ready to add a *groov* RIO and configure I/O points.
- **In an Ignition SCADA**—Ignition Edge in GRV-R7-MM2001-10 connects to Allen-Bradley®, Siemens®, and Modbus®/TCP devices via OPC UA and offers efficient IIoT communications using MQTT with Sparkplug B payload (requires purchase of license [GROOV-LIC-EDGE8](#)).
- **In a custom control program**—You can access *groov* RIO I/O programmatically through OptoMMP or REST APIs.

groov RIO as a PLC

Automation control programming and configurable I/O in one box? It's possible with the on-board CODESYS runtime engine (requires purchase of [GROOV-LIC-CRE-RIO](#)). Download and install version 3.1.0.0 or later of the [Opto 22 Library Package for CODESYS Development System](#) to create applications that you can then download to your *groov* RIO. Running a control program, your *groov* RIO becomes a compact PLC, great when the local I/O monitoring footprint is small but your application requires access to remote I/O.

Independent PID Loop Control

A *groov* RIO universal I/O module can independently solve PID loops when any analog output is configured as the Control Output (CO) of the loop. Up to four independent loops are supported, with configurable loop times.

Leverage Existing *groov* and SNAP PAC Knowledge

If you already have *groov* EPIC or SNAP PAC control systems, you can expand your I/O footprint with the addition of *groov* RIOs. *groov* RIO works as remote I/O with *groov* EPIC and SNAP PACs, and it uses many of the same principles and technologies found in your existing *groov* EPIC or SNAP PAC control system:

- *groov* Manage for I/O configuration and other tools to help manage your *groov* RIO
- MQTT to transmit Sparkplug or string payloads
- Node-RED for simple data flows
- OpenVPN client to connect to an OpenVPN server running a virtual private network
- PAC Control for programming and I/O configuration
- Distributed control—I/O features like counting, latching, totalization, and minimum & maximum values continue to run independently on *groov* RIO, even if communication to the controller is lost.

groov RIO in an Opto 22 Control System, also Responding to a Modbus/TCP Master and Custom Program

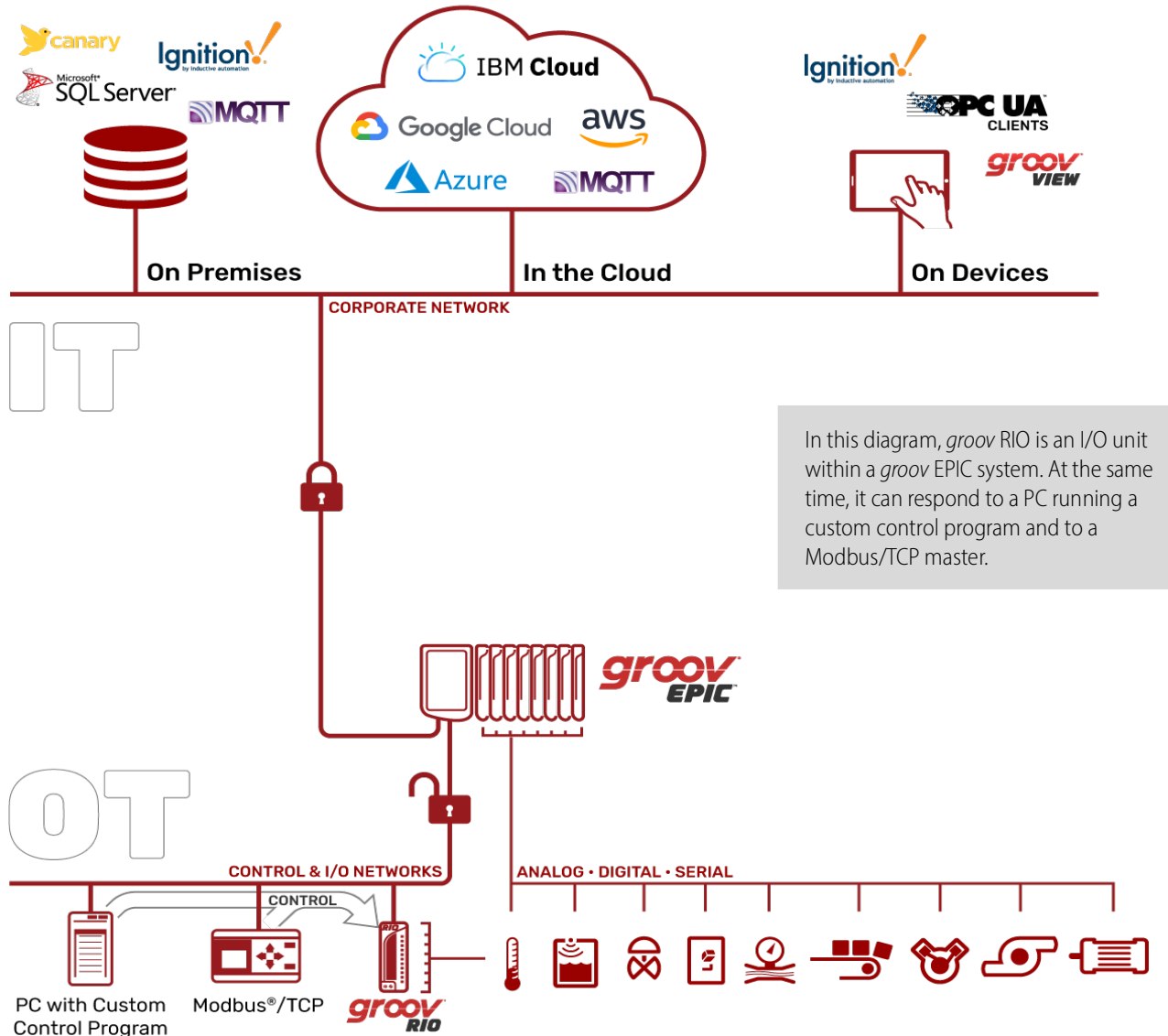

Security

groov RIO provides several features to help keep your data secure.

User account management—*groov* RIO has no default username or password. You must set up the first Admin user account and remember its username and password, as these user credentials are secure and cannot be recovered. You can also locally create more users, set their passwords and permissions, and set global and individual user session timeouts.

Centralized user management—*groov* RIO can help you scale your control system by supporting user management through LDAP. Configure your *groov* RIOs to connect to your LDAP-compatible directory service, then your IT staff can manage users/groups from one spot. LDAP support can also help satisfy data integrity requirements in regulated industries.

VPN client—You can securely connect to *groov* RIO using a VPN. Support is provided for OpenVPN servers.

Configurable firewall—Configure the device (or host) firewall in *groov* RIO for greater security. You can control which ports, protocols, and interfaces are open for incoming connections to the services listening on each port number. For example, you should disable the ports of unused protocols.

Security certificate management—You have control over the Client and Server Security Certificates used with your *groov* RIO, from a self-signed certificate you can create on the module to a signed certificate from an internet-based Certificate Authority (CA). See the *groov* RIO EMU User's Guide for details.

Need help? Try the *groov* RIO Explorer

It can sound overwhelming sifting through thousands of unique field I/O combinations, so we created an online app to help you select the right combination and correctly wire your field devices to your *groov* RIO: [the *groov* RIO Explorer](#).

With this web app, you can select which function you want on each channel, and then the app displays the corresponding wiring diagram. You can print out the wiring diagram or save it as an image for reference.

LEDs, NETWORK INTERFACES, PORTS, AND CONNECTORS

The LEDs, network interfaces, USB port, and connectors (terminal and power supply) on the *groov* RIO offer features to help you review the status and health of your *groov* RIO, as well as connect it to a power supply, a network, and field devices. For more information about these features and how to utilize them, see [groov RIO Universal I/O User's Guide](#) (form 2324).

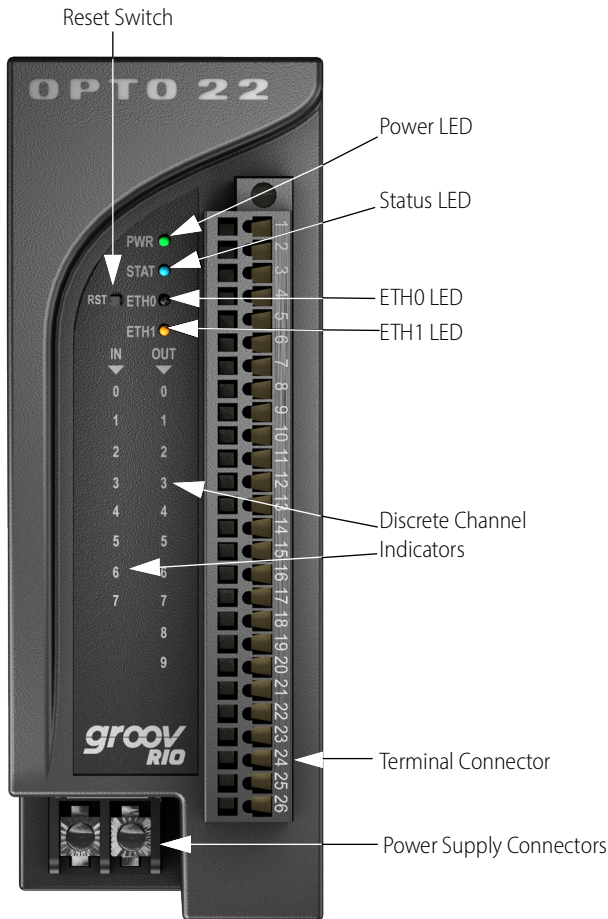

LEDs

LED	Indicates															
PWR	The status of power. <ul style="list-style-type: none"> • Solid green—<i>groov</i> RIO is powered on. • Solid red—<i>groov</i> RIO is restarting. 															
STAT	Indicates whether <i>groov</i> RIO is running or resetting. <ul style="list-style-type: none"> • Solid green—<i>groov</i> RIO is running normally. • Blinking green—<i>groov</i> RIO is starting (power on) or restarting (initiated by Reset button). • Blinking between green and red—<i>groov</i> RIO is resetting to factory defaults. 															
ETH0, ETH1	Network connection speed and whether there is any transmission activity: <table border="1"> <thead> <tr> <th>Color</th> <th>Connection Speed</th> <th>Transmission Activity</th> </tr> </thead> <tbody> <tr> <td>Solid green</td> <td>1 Gbps</td> <td>No</td> </tr> <tr> <td>Blinking green</td> <td>1 Gbps</td> <td>Yes</td> </tr> <tr> <td>Solid orange</td> <td>10 or 100 Mbps</td> <td>No</td> </tr> <tr> <td>Blinking orange</td> <td>10 or 100 Mbps</td> <td>Yes</td> </tr> </tbody> </table>	Color	Connection Speed	Transmission Activity	Solid green	1 Gbps	No	Blinking green	1 Gbps	Yes	Solid orange	10 or 100 Mbps	No	Blinking orange	10 or 100 Mbps	Yes
Color	Connection Speed	Transmission Activity														
Solid green	1 Gbps	No														
Blinking green	1 Gbps	Yes														
Solid orange	10 or 100 Mbps	No														
Blinking orange	10 or 100 Mbps	Yes														

Terminal Connector

The terminal connector provides a spring-clamp wiring system to securely connect the wires from your field devices/electrical systems to *groov* RIO. To learn how to use the spring-clamp wiring system, see ["Pinout and Wiring"](#) on page 16.

The terminal connector for GRV-R7-MM1001-10 and GRV-R7-MM2001-10 is gray in color. This terminal connector is designed to accurately read thermocouple inputs, and energy. If a terminal connector is black, all the pin numbers are labeled, and there are no other labels, then you can use that terminal connector on most *groov* I/O modules. For a list of which terminal connectors work with which *groov* I/O or *groov* RIO modules, see [groov Accessories Data Sheet](#) (form 2314).

Power Supply Connector

To supply power with an external power supply, Opto 22 recommends you follow these wiring guidelines:

- Use a 10 to 32 V DC power source or supply.
- Use wire size 22 to 14 AWG. Keep the wires as short as possible.

Note: If you are using an external power supply, do **NOT** connect PoE. PoE cannot be used as an alternate power source.



Reset Switch

This switch reboots your *groov* RIO or can reset it to factory defaults, erasing all the changes you made to your module and setting the firmware to the version installed when it was shipped.

Discrete Channel Indicators

There are two columns of indicators on the face of *groov* RIO to indicate state for discrete channels:

- Input on the left.
- Output on the right.

When a channel is configured for discrete input or output, its corresponding indicator lights up when the channel is on.

Power Supply Wiring Diagram

Before wiring the *groov* RIO to an external power supply, verify that your wiring cables conform to the requirements described above.



Network Ports

The Ethernet ports are part of an internal Ethernet switch, which means you can network *groov* RIOs in a daisy-chain configuration or in a standard star configuration using either Ethernet port. Both ports share the same IP address.

The network ports support speeds of up to 1 Gbps. Check that your Ethernet cable is rated for the speed of your network.

The **ETH1** port, when connected to Power Sourcing Equipment (PSE)—for example, a PoE switch—through a PoE-rated Ethernet cable, can power the *groov* RIO module. Opto 22 recommends you select a PSE that supports IEEE 802.3af and has sufficient power available for all the powered devices (PDs) connected to it.

Do not supply power through PoE as an alternative or backup to powering through a separate external power supply. Supply power through an external power supply or PoE, but not both.

USB Port

The USB port acts as a USB host device that can help you extend the capabilities of the *groov* RIO. You can connect a:

- WiFi adapter to add wireless connectivity.
- USB-to-serial adapter to read and write data to serial devices.
- USB memory stick to expand the storage space; for example, to increase data logging capacity.

The wireless interface WLAN0 (which becomes available when you plug in a WiFi adapter) does not provide access to other *groov* RIOs in a daisy-chain configuration because this interface has a separate IP address on a separate subnet.

Wireless Connectivity

The following WiFi USB adapters have been tested and proven to be compatible with *groov* RIO:

Device Manufacturer	Model
Netis	WF2190
Linksys	AE6000
TP-Link	Archer T1U
Sabrent	AC600

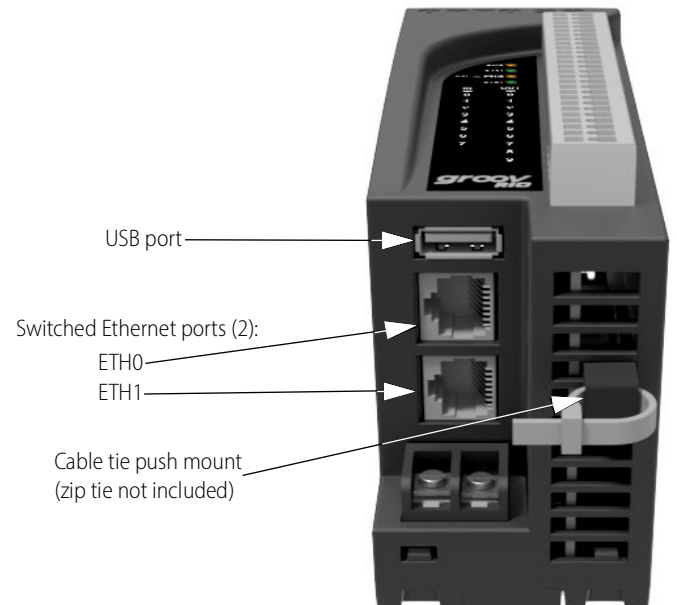

Cable Tie Push Mounts (Optional Use)

Cable tie push-mounts can help you manage wires. Each *groov* RIO includes two user-installable cable tie push mounts that snap into a vent, providing a sturdy loop through which you can thread a zip tie (not included), and then bundle the wires together with the zip tie.



FEATURES AND SPECIFICATIONS

Features

The following table lists the features available for each signal type. Note that some signal types are available only on specific channels, as listed in the "Channels" row.

GRV-R7-MM1001-10 GRV-R7-MM2001-10		Signal Type					
	DI: • Discrete • Switch Input, Powered	DI: • Discrete • Switch Input, Powered	DO: • DC Sinking	DO: • Form C Mech. Relay	AI: • Voltage • ICTD • Thermistor • Resistor	AI: • Current • Thermocouple • Millivolt	AO: • Voltage • Current
Channels	0-1	2-7	0-7	8-9	0-7	0-3	4-7
Features							
On/off State	●	●	●	●			
On/off Latching	●						
Counting	●						
On/off Totalization	●						
Frequency Measurement	●						
Period Measurement	●						
Pulse Measurement	●						
Scaling					●	●	●
Offset and Gain					●	●	
Minimum/Maximum Values					●	●	
Average Filter Weight					●	●	
Simple Moving Average							
Analog Totalizing					●	●	
Output Pulsing / TPO			●				
Ramping							●
Clamping							●
Watchdog Timeout Value			●	●			●
Quality Indication					●	●	●

Specifications

The specifications are divided into two categories: common and by signal type. The common category (located at the bottom of the following table, [page 14](#)) lists the specifications that apply to all channels, regardless of the signal type you select. The by signal type category applies when the channel is configured for that particular signal type.

Specification	GRV-R7-MM1001-10 GRV-R7-MM2001-10
Voltage Input	
Available Channels	0–7
Input Range	0–10 V DC
Over-range Limit	0–11 V DC
Resolution	0.5 mV
Accuracy	±0.05% of range (±5 mV)
Gain Temperature Coefficient	30 ppm/°C
Offset Temperature Coefficient	15 ppm/°C
Input Impedance	> 425 kOhms
Data Refresh Time	550 ms
50 / 60 Hz rejection	> 90 dB
Current Input	
Available Channels	0–3
Input Range	0–20 mA, 4–20 mA
Over-range Limit	0.0–20.8 mA, 2.0–20.8 mA
Recommended Fuse	32–40 mA, Fast Acting (for example, Eaton S500-32-R)
Resolution	1.0 µA
Accuracy	±0.05% (±10 µA)
Gain Temperature Coefficient	30 ppm/°C
Offset Temperature Coefficient	15 ppm/°C
Input Voltage Drop (±10%)	0.9 V @ 4 mA, 2.0 V @ 20 mA, 25 °C
Equivalent Input Impedance (±10%)	225 Ohms @ 4 mA, 100 Ohms @ 20 mA, 25 °C
Data Refresh Time	550 ms

Specification	GRV-R7-MM1001-10 GRV-R7-MM2001-10
50 / 60 Hz rejection	> 90 dB
ICTD Input	
Available Channels	0–7
Input Range with ICTD Probe	-40 to +100 °C
Resolution	0.04 °C
Accuracy with ICTD Probe	±1.0 °C (1.8 °F)
Gain Temperature Coefficient	30 ppm/°C
Offset Temperature Coefficient	60 ppm/°C
Data Refresh Time	550 ms
50 / 60 Hz rejection	> 90 dB
Thermocouple Input	
Available Channels	0–3 (see Note)
Nominal Input Range	-75 to +75 mV
Full Scale Range	-78 to +78 mV
Input Resolution	3 microvolts
Input Impedance	> 1 megohm
Data Refresh Time	550 ms
50 / 60 Hz rejection	> 90 dB
Thermocouple ITS90 Types	± Accuracy / Resolution
B: 90 °C to 1,820 °C	7 °C / 0.4 °C
E: -80 °C to 1,000 °C	2 °C / 0.1 °C
J: -100 °C to 1,200 °C	2 °C / 0.1 °C
K: -80 °C to 1,372 °C	2 °C / 0.1 °C
N: -100 °C to 1,300 °C	3 °C / 0.1 °C
R: 100 °C to 1,768 °C	7 °C / 0.3 °C
S: 100 °C to 1,768 °C	7 °C / 0.3 °C
T: -60 °C to 400 °C	3 °C / 0.1 °C
Note: To achieve the best thermocouple accuracy when also using current outputs or discrete outputs, always configure thermocouples on the lowest channel numbers and outputs on the highest channel numbers.	
Millivolt Input	
Available Channels	0–3
Input Ranges	±150 mV, ±75 mV, ±25 mV
Over-range Limits	±165.0 mV, ±78.0 mV, ±27.5 mV
Resolution	10 µV, 3 µV, 2 µV
Accuracy	±0.1% of Full Scale (±150 µV) ±0.1% of Full Scale (±75 µV) ±0.2% of Full Scale (±50 µV)

Specification	GRV-R7-MM1001-10 GRV-R7-MM2001-10
Input Impedance	> 1 MOhms
Data Refresh Time	450 ms
50 / 60 Hz rejection	> 90 dB
Thermistor Input (Requires firmware version 3.0.0 or later)	
Available Channels	0–7 (see Note)
Input Range (Ohm)	0–400 k
Accuracy (Ohm @ Range)	greater of 3 Ohm or 0.5%@0–25k, 400@25k–50k, 900@50k–75k, 1.5k@75k–100k, 5k@100k–200k, 20k@200k–400k
Gain Temperature Coefficient	500 ppm/°C
Resolution (Ohm @ Range)	0.5@0–1k, 1@1k–5k, 2@5k–10k, 5@10k–25k, 50@25k–100k, 200@100k–200k, 700@200k–400k
Power Dissipation @ Resistance (µW @ Ohm)	375@1k, 950@5k, 1075@10k, 875@25k, 600@50k, 450@75k, 350@100k, 200@200k, 100@400k
Predefined Thermistor Curves	Accuracy (°C) @ Range (°C)
2252	0.2 °C @ -40 °C to 70 °C 2.5 °C @ 70 °C to 150 °C
3K	0.2 °C @ -40 °C to 70 °C 2.5 °C @ 70 °C to 150 °C
10K type 2	0.75 °C @ -40 °C to -20 °C 0.2 °C @ -20 °C to 120 °C 0.6 °C @ 120 °C to 150 °C
10k type 3	0.5 °C @ -40 °C to -20 °C 0.3 °C @ -20 °C to 120 °C 0.6 °C @ 120 °C to 150 °C
Custom	depends on curve
Data Refresh Time	550 ms
Note: To achieve the best thermistor accuracy when also using current outputs, always configure thermistors on the lowest channel numbers and current outputs on the highest channel numbers.	
0–400 kOhm Input (Requires firmware version 3.0.0 or later)	
Available Channels	0–7 (see Note)
Input Range (Ohm)	0–400k
Accuracy (Ohm @ Range)	greater of 3 Ohm or 0.5%@0–25k, 400@25k–50k, 900@50k–75k, 1.5k@75k–100k, 5k@100k–200K, 20k@200k–400k
Gain Temperature Coefficient	500 ppm/°C

Specification	GRV-R7-MM1001-10 GRV-R7-MM2001-10
Resolution (Ohm @ Range)	0.5@0–1k, 1@1k–5k, 2@5k–10k, 5@10k–25k, 50@25k–100k, 200@100k–200k, 700@200k–400k
Power Dissipation @ Resistance (µW@Ohm)	375@1k, 950@5k, 1075@10k, 875@25k, 600@50k, 450@75k, 350@100k, 200@200k, 100@400k
Data Refresh Time	550 ms
Note: To achieve the best resistance accuracy when also using current outputs, always configure the 0-400 kOhm channel type on the lowest channel numbers and current outputs on the highest channel numbers.	
Discrete DC Input	
Available Channels	0–7
Input Voltage Range	5–30 V DC
Minimum ON Voltage	5.0 V
Maximum OFF Voltage	1.5 V
Input Impedance	> 425 KOhms
Max. Input Frequency (50% square wave)	10000 Hz
Switch Input, Powered	
Available Channels	0–7
Open Circuit Voltage (Switch Open)	10.5 V (minimum)
Channel Current Limit	1.1 mA max.
Channel Operating Current	0.63 mA typical
Minimum Off Resistance	3300 Ohms
Maximum On Resistance	1200 Ohms
Minimum ON Voltage	5 V
Maximum OFF Voltage	1.5 V
Maximum Continuous Survivable Input Voltage	32 V
Input Impedance	> 425 KOhms
Max. Freq. (50% square wave)	10000 Hz
Discrete Counter Input	
Available Channels	0–1
Input Voltage Range	5–30 V DC
ON Threshold	5 V
OFF Threshold	1.5 V
Input Impedance	> 425 KOhms
Max. Frequency (50% square wave): State, Latches, Counter	10000 Hz

Specification	GRV-R7-MM1001-10 GRV-R7-MM2001-10
Max. Frequency (50% square wave): On/Off pulse width, Period, Frequency	2000 Hz
Max. Frequency (50% square wave): On/Off totalization	750 Hz
Pulse Width Measurement Resolution	100 microseconds
Pulse Width Measurement Error (50% square wave)	0.1% 0 to 20 Hz
	1% 21 to 200 Hz
	5% 201 to 2000 Hz
Period/Frequency Error (50% square wave)	0.05% 0 to 20 Hz
	0.1% 21 to 200 Hz
	1% 201 to 2000 Hz
Discrete DC Sinking Output	
Available Channels	0–7 (4-7 if using any thermocouple inputs)
Line Voltage Range	5–30 V DC
Maximum Continuous Current	1.0 A
Peak Current (< 10 ms)	4.0 A
Recommended Fuse / Circuit Breaker	1 A at 30 V DC
Output Voltage Drop	175 mV at 1 A
Off-State Leakage (per channel)	< 80 μ A at 24 V, -20 to +70 °C
Peak Blocking Voltage	32 V
TPO Period (min, max, resolution)	0.004, 4294967, 0.001
Turn On / Off Time	20 ms nominal
Form C Relay Output	
Available Channels	8, 9
Line Voltage Range	0–250 V AC or 5–30 V DC
Clamp Voltage	440 V nominal
Current Rating	5 A per channel
Surge Current	6 A peak for 1 second
Recommended Fuse / Circuit Breaker	5 A at 250 V AC / > 30 V DC per channel
Initial Contact Resistance	< 100 milliohms
Turn On Time	8 ms
Turn Off Time	4 ms
Operating Life (to specification)	Min. 30,000 cycles at max. ratings
Mechanical Life	Min. 10,000,000 cycles
Voltage Output	

Specification	GRV-R7-MM1001-10 GRV-R7-MM2001-10
Available Channels	4–7
Range	0–10 V
Resolution	2.5 mV
Accuracy	±0.3% of range (±30 mV)
Gain Temperature Coefficient	50 ppm/°C
Offset Temperature Coefficient	20 ppm/°C
Output Slew Rate	> 15 V/ms
Minimum Load Resistance	7.5 kOhms
Output Impedance	< 10 Ohms
Short-circuit Current	20 mA
Data Refresh Time	Nominal 20 ms. Proportional to I/O scan time.
Current Output	
Available Channels	4–7
Output Range	0–20 mA
Resolution	5 µA
Accuracy	±0.325% of range (±65 µA)
Gain Temperature Coefficient	60 ppm/°C
Output Slew Rate	> 10 mA/ms
Maximum Loop Resistance	700 Ohms
Data Refresh Time	Nominal 20 ms. Proportional to I/O scan time.
Common Specifications	
Ethernet	Two switched Gigabit ports; Ethernet communication daisy-chainable. Supports Auto MDI-X (crossover cable not needed)
USB	One Port, USB 2.0 HS
Memory	GRV-R7-MM1001-10: 1 GB RAM, 4.0 GB disk space GRV-R7-MM2001-10: 2 GB RAM, 7.0 GB disk space
Power Supply	10–32 V DC or 802.3af PoE Class 0 (ETH1)
Power Consumption	10 W
Max. Survivable Input (channels 0 - 7)	32 V DC
Isolation (between channels 0 - 7)	None
Isolation (between channel 8 or 9 and all others)	3000 V AC _{rms} 1 min.
Isolation (field to Ethernet / power input)	1500 V AC _{rms} 1 min.
Minimum <i>groov</i> RIO Firmware Version	GRV-R7-MM1001-10: N/A GRV-R7-MM2001-10: 3.0.0
Minimum <i>groov</i> EPIC Firmware Version	GRV-R7-MM1001-10: 2.0.0 (3.0.0 for Thermistors) GRV-R7-MM2001-10: 3.0.0

Specification	GRV-R7-MM1001-10 GRV-R7-MM2001-10
Minimum PAC Project Version	GRV-R7-MM1001-10: 10.3000 (10.3003 for Thermistors) GRV-R7-MM2001-10: 10.3003
Minimum Library Package for CODESYS Version	GRV-R7-MM1001-10: 2.0.0.0 (2.0.1.0 for Thermistors) GRV-R7-MM2001-10: 2.0.1.0
Field Connector Wire Size	28–14 AWG
Torque, field connector screw	2.5 in-lb (0.28 N-m)
Power Connector Wire Size	22–14 AWG
Torque, DC power connector screws	7.0 in-lb (0.79 N-m)
Torque, panel mount tab screw	2.0 in-lb (0.23 N-m)
Temperature (operating)	-20 °C to +70 °C
Temperature (storage)	-40 °C to +85 °C
Relative Humidity (non-condensing)	5–95%
MTBF (minimum, 25 °C)	1.2 Mhrs
Agency Approvals	UL/cUL(Class 1 Div. 2); CE, ATEX(Category 3, Zone 2), RoHS; DFARS; CB Scheme; UKCA
Warranty	30 months

Wire Assignments

The following wire assignments apply to the thermocouple signal type:

Type	-	+	Range
B	Red	Gray	+90 °C to +1,820 °C
E	Red	Purple	-80 °C to +1,000 °C
J	Red	White	-100 °C to +1,200 °C
K	Red	Yellow	-80 °C to +1,372 °C
N	Red	Orange	-100 °C to +1,300 °C
R,S	Red	Black	100 °C to +1,768 °C
T	Red	Blue	-60 °C to +400 °C

MOUNTING ON DIN RAIL

Before mounting your *groov* RIO:

- Ensure that the vents around the module are not obstructed.
- Ensure that the mounting location meets the clearances described in "Orientation and Clearances".

The module is built with a DIN rail adapter for use on 35 mm DIN rail. No additional assembly is required.

1. Hold your module so that the Opto 22 logo is at the top and at an angle such that the top of the DIN rail adapter is away from the DIN rail and the bottom of the DIN rail adapter can slide behind the bottom lip of the DIN rail. See the circled area in the image below.

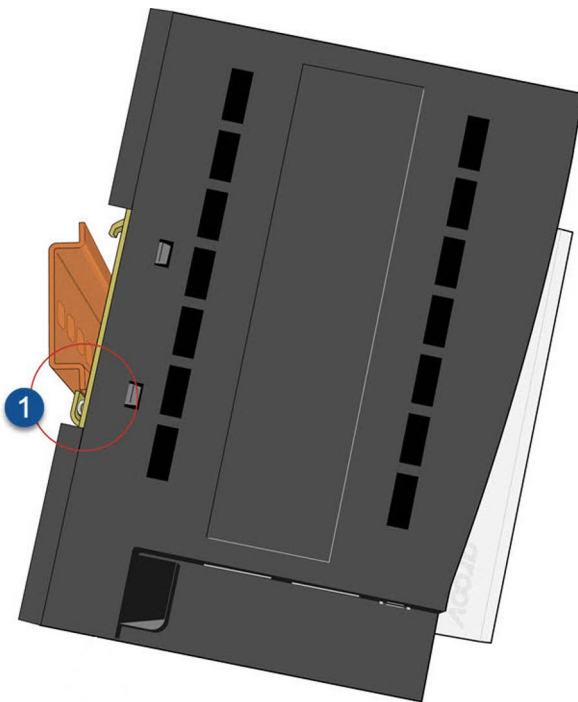

2. Push the bottom part of the module upward, making sure that you feel the clip catch on to the rail, and simultaneously push the

top half of the module toward the DIN rail until the top of the DIN rail adapter engages the top lip of the DIN rail.

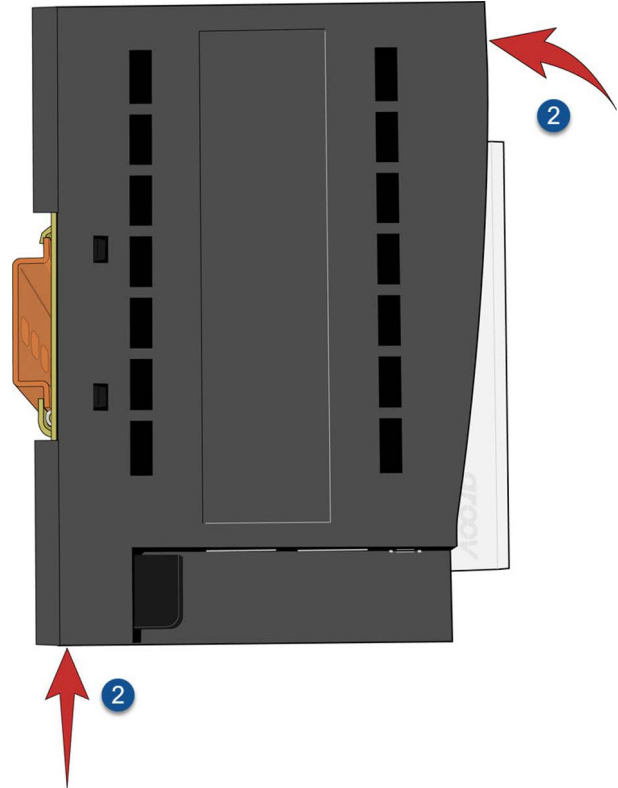

Before you release the module, verify that the top and bottom of the DIN rail adapters have engaged the DIN rail.

ORIENTATION AND CLEARANCES

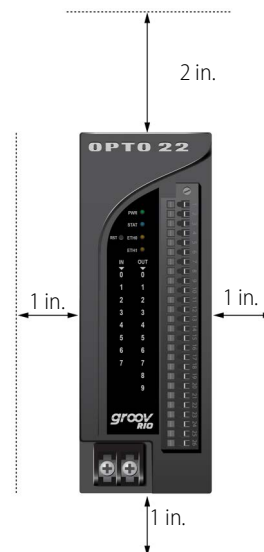

Make sure that there is a minimum of 2 inches clearance on the top, and 1 inch clearance on the bottom, each side, and in front of RIO, after it is mounted. Mount RIO as shown in the diagram: with the Opto 22 logo at the top. Compliance with these guidelines helps ensure that *groov* RIO performs as described in the specifications.

MOUNTING ON A PANEL

Before mounting your *groov* RIO on a panel:

- Ensure that the vents around the module are not obstructed.
 - Review the clearance requirements described in "[Orientation and Clearances](#)" on page 16.
1. Extend and secure the tabs to expose the mounting holes on each tab:
 - a. Turn the module so you can see the backside.

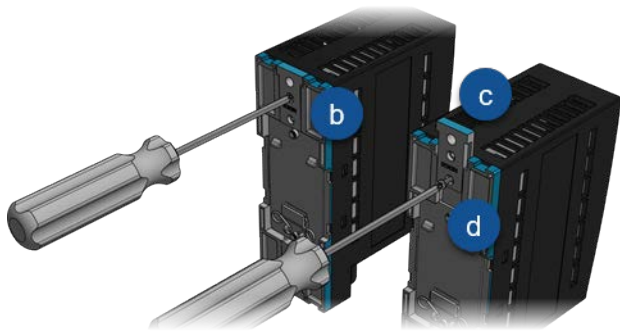

- b. With a small Phillips screwdriver, remove the tab-locking screw on one tab.
 - c. Slide the tab out so the middle hole on the tab aligns with the screw hole on the module.
 - d. Reinsert the tab-locking screw to the torque indicated for the panel mount tab screw in the specifications table on .
 - e. Repeat steps b through d with the other tab.
2. Use the module as a template to mark where the holes should be drilled and tapped on the panel and verify placement before attaching the module.
3. Attach the module to the panel with screws (not provided):
 - a. Tighten a screw into one tab *close* to the torque indicated for the panel mount tab screw in the specifications table on .
 - b. Tighten another screw into the second tab *up* to the torque indicated for the panel mount tab screw.
 - c. Return to the first screw and re-tighten the screw up to the torque indicated.

INSERTING A CABLE TIE PUSH MOUNT

Each *groov* RIO comes with two user-installable cable tie push mounts. You only need to insert one mount.

1. Identify the thin side of the mount, then position it over a vent so that the thin side faces the ports and is away from the PCB, which is visible through the vents (see image on [page 7](#)).
2. With one hand, hold the *groov* RIO down on a sturdy surface. With the other hand, push the mount in, beginning with the thin side. Push until you hear a loud click. Verify that the mount is securely inserted by gently pulling on it; it should not come out.

Thread a zip tie (not included) through the mount. Collect the wires into a bundle, wrap the zip tie around the bundle, then clip the excess zip tie.

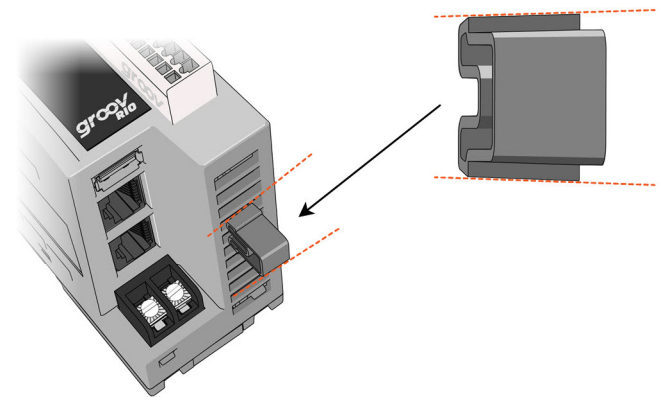

PINOUT AND WIRING

Before you begin wiring, do the following tasks:

- Select the appropriate wire. The terminal connectors are rated for 28–14 AWG wire. If you're using stranded wire, you can make an easier and better connection by tinning the strands or adding ferrules.
- Ensure that you have the *groov* spring-clamp terminal tool, typically supplied with your *groov* RIO. (You can order a replacement on our website, www.opto22.com. Search for [GRV-TEX-SCTOOL](#).)
- It may be easier to insert wires if you remove the terminal connector from the module. To remove the terminal connector,

loosen the terminal connector screw at one end of the connector, then pull the connector straight out to remove it from the module.

- If you have never used a spring-clamp wiring system, take a moment to familiarize yourself with the diagram below. Insert the spring-clamp terminal tool in the clamp release hole. Insert field wires in the field wiring holes.
- If you look into the field wiring hole, you will see a highly reflective surface. If you can see that surface, that means that the clamp is closed.

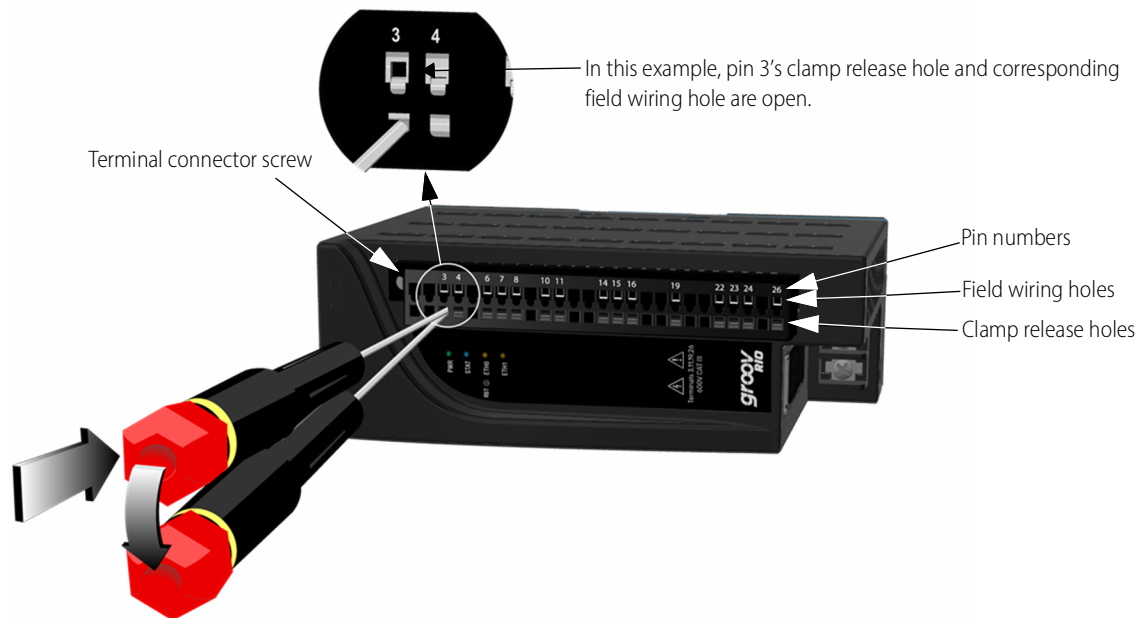

Connecting Field Wires

CAUTION: For electrical safety, before starting, de-energize field devices wired to the terminal connector.

1. Orient the module or terminal connector to match the wiring diagrams on the following page.
2. To make it easier to handle the spring-clamp terminal tool and the field wires, secure the module by doing one of the following:
 - If you are working only with the terminal connector, secure the terminal connector with a clamp.
3. Insert the spring-clamp terminal tool into the clamp release hole, then press and hold down the tool to open the clamp. Look into the field wiring hole. If it is dark, the clamp is open. You can go to [step 4](#). If you can still see the highly reflective surface, gently push down again and maintain downward pressure on the

spring-clamp terminal tool. Look into the field wiring hole. If it is dark, the clamp is open.

Note: If you push down too hard, the spring-clamp terminal tool might pop out of the clamp release hole.

4. Insert the wire into the field wiring hole until it meets complete resistance. Then pull out the spring-clamp terminal tool.
5. Test that the wire is secure by gently pulling on it. If the wire pulls out, repeat steps 3 and 4.

To remove a wire, push the spring-clamp terminal tool into the clamp release hole as described in [step 3](#) above, and then pull the wire out.

WIRING DIAGRAM



Notes:

1. You must supply external fusing.
2. Opto 22 recommends adding external fusing. Review the specification table for specific ratings. Compatible with an externally powered or self powered transmitter. Wiring for externally powered transmitter is shown on channels 0 and 1. Wiring for a self powered transmitter is shown on channels 2 and 3.
3. Thermocouple inputs and discrete sinking outputs cannot be mixed on channels 0-3.

DIMENSIONS: *groov RIO*

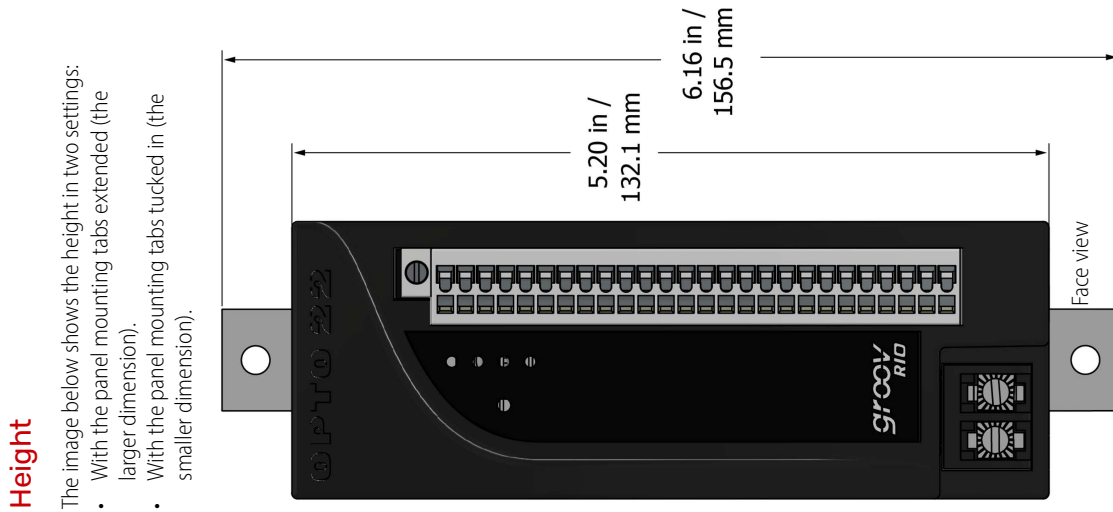
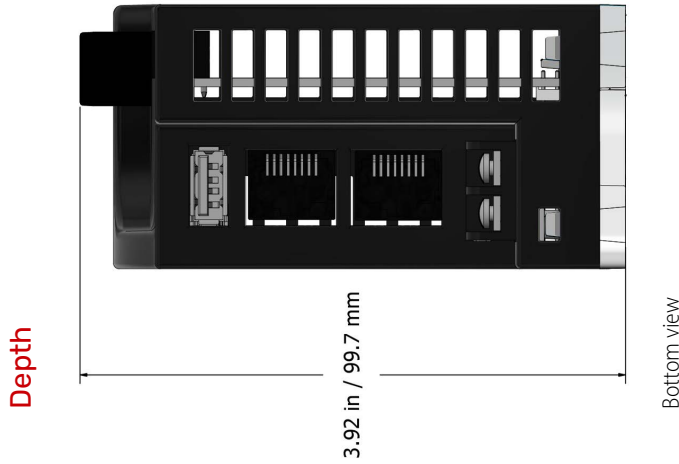

Note: If you attach a cable tie mount, the bundle of wires you attach to the mount may exceed the height of the module with the panel mounting tabs extended.