



# EV5026-V-00A

## 16V, 20A, Hot-Swap Intelli-Fuse Solution Evaluation Board

### DESCRIPTION

The EV5026-V-00A is an evaluation board designed to demonstrate the capabilities of the MP5026, a fully integrated hot-swap protection device. The EV5026-V-00A allows for reference circuit evaluation of the MP5026. The MP5026 is designed to protect circuitry on its output from transients on its input. It also protects its input from undesired shorts and transients coming from its output. The device can achieve up to 20A of continuous output current ( $I_{OUT}$ ) per device at room temperature.

The MP5026 limits the inrush current to the load when a circuit card is inserted into a live backplane power source, which limits the power supply voltage drop. The MP5026 also limits the internal MOSFET current ( $I_{FET}$ ) by controlling the gate voltage ( $V_{GATE}$ ) via a low-power resistor connected between the ISET pin and ground as well as soft-start (SS) ramp.

The MP5026 offers many features to simplify system design, such as an integrated current mirror that monitors  $I_{OUT}$  and the integrated on-die temperature sense. This eliminates the need for an external current-sense power resistor, power MOSFET, and temperature-sense device.

The MP5026 provides a variety of fault protections, including over-current protection (OCP), short-circuit protection (SCP), over-temperature protection (OTP), damaged MOSFET detection, over-voltage protection (OVP), and under-voltage protection (UVP).

The MP5026 is available in an LGA-26 (4mmx4mm) package. The EV5026-V-00A has 4 layers, which are each 2oz, and the total size is 7.15cmx6.35cm.

### PERFORMANCE SUMMARY

Specifications are at  $T_A = 25^\circ\text{C}$ , unless otherwise noted.

Parameters	Conditions	Value
Input voltage ( $V_{IN}$ ) range		2.7V to 16V
Soft-start time ( $t_{SS}$ )	$C_{SS} = 100\text{nF}$	9.9ms
Over-current protection (OCP) limit during steady state	$R_{ISET} = 12\text{k}\Omega$	25A
OCP limit during soft start		20A
Short-circuit protection (SCP) limit		50A
Insertion delay time ( $t_{IDT}$ )	$C_{TIMER} = 10\text{nF}$	3ms
OCP delay time ( $t_{OC}$ )		300 $\mu\text{s}$
Over-voltage protection (OVP) rising threshold	$R_{OV\_UP} = 100\text{k}\Omega$ , $R_{OV\_BOT} = 10\text{k}\Omega$	13.3V
OVP falling threshold		12.5V
Under-voltage protection (UVP) rising threshold	$R_{EN\_UP} = 365\text{k}\Omega$ , $R_{EN\_BOT} = 100\text{k}\Omega$	5.6V
UVP falling threshold		5.1V
LOADEN blanking time	$C_{ENTM} = 1\mu\text{F}$	1.1s

EVALUATION BOARD

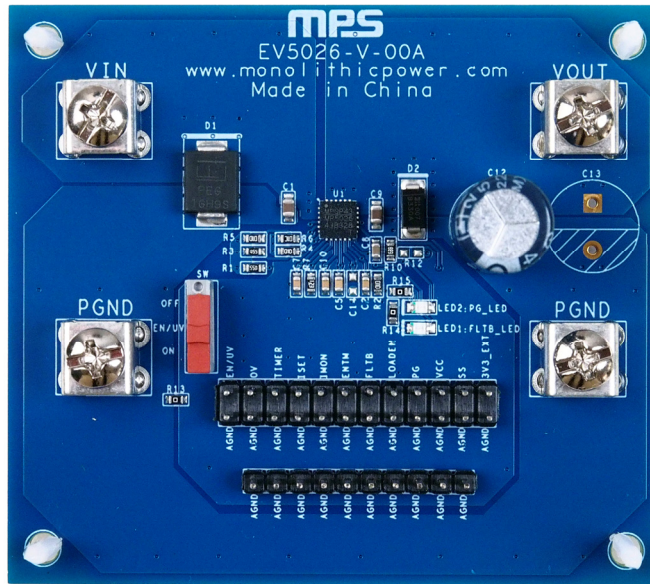

LxWxH (7.15cmx6.35cmx1.6cm)

Board Number	MPS IC Number
EV5026-V-00A	MP5026GLRT

## QUICK START GUIDE

To start up the EV5026-V-00A, follow the steps below:

### Start-Up through VIN

1. Preset the power supply between 2.7V and 12V, then turn off the power supply. <sup>(1)</sup>
2. Connect the power supply terminals to:
  - a. Positive (+): VIN
  - b. Negative (-): PGND
3. Connect the load terminals to:
  - a. Positive (+): VOUT
  - b. Negative (-): PGND
4. Turn the EN/UV switch (SW) on. Ensure the switch remains on. <sup>(2)</sup>
5. After making the connections, turn on the power supply. The output voltage ( $V_{OUT}$ ) should start up automatically.

### Start-Up through EN/UV

1. Connect the power supply terminals to:
  - a. Positive (+): VIN
  - b. Negative (-): PGND
2. Connect the load terminals to:
  - a. Positive (+): VOUT
  - b. Negative (-): PGND
3. Turn SW off, then turn on the power supply.  $V_{OUT}$  remains low during this time.
4. Turn SW on.  $V_{OUT}$  should start up automatically.

#### Notes:

- 1) If testing with a continuous input voltage ( $V_{IN}$ ) that exceeds 12V, remove the existing TVS diode (D1) and replace them with the appropriate TVS diodes according to  $V_{IN}$ .
- 2) Ensure that the EN/UV voltage is greater than its rising threshold voltage (typical 1.21V).

### EVALUATION BOARD SCHEMATIC

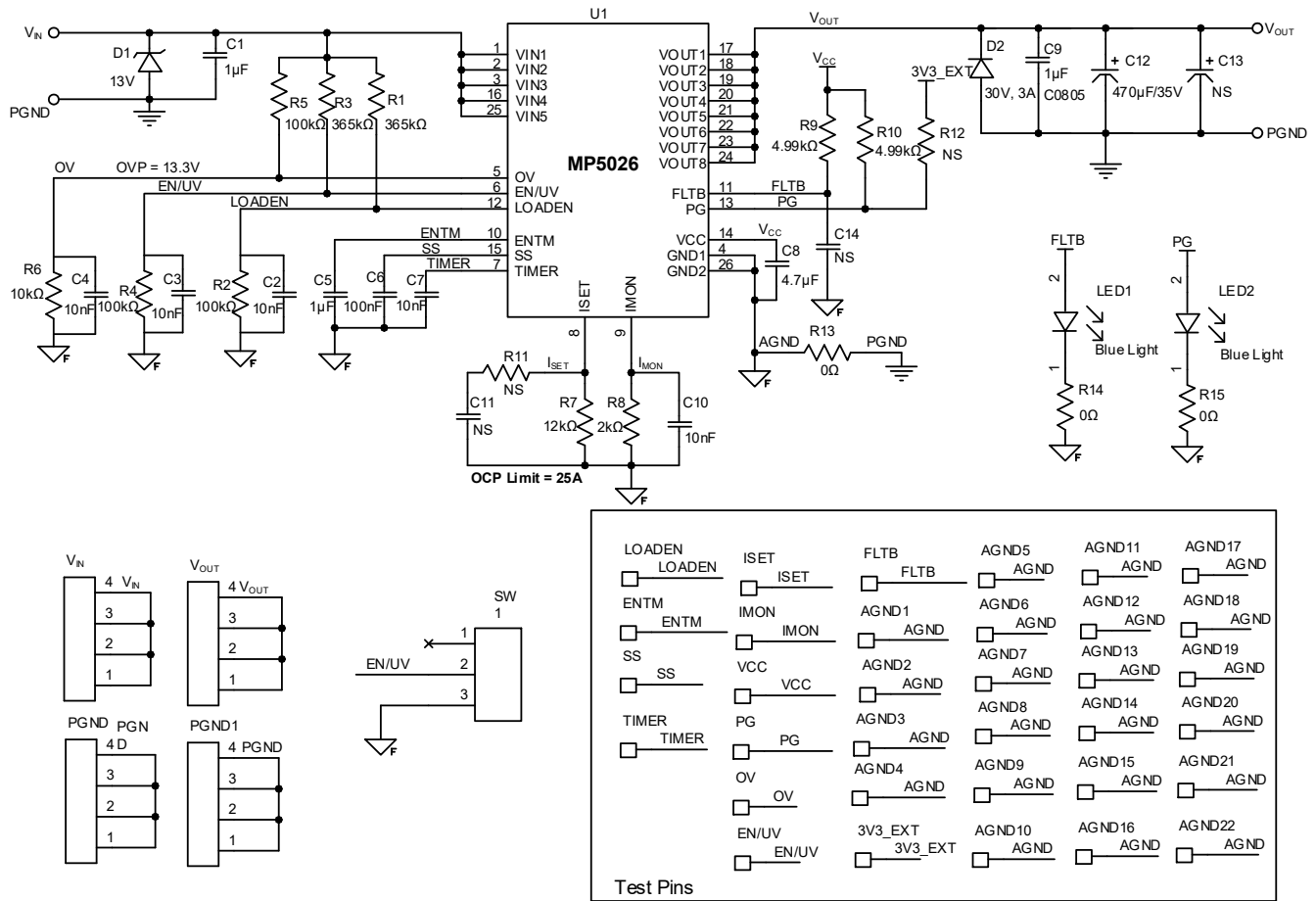

Figure 1: Evaluation Board Schematic

**EV5026-V-00A BILL OF MATERIALS**

Qty	Ref	Value	Description	Package	Manufacturer	Manufacturer PN
34	AGND1, AGND2, AGND3, AGND4, AGND5, AGND6, AGND7, AGND8, AGND9, AGND10, AGND11, AGND12, AGND13, AGND14, AGND15, AGND16, AGND17, AGND18, AGND19, AGND20, AGND21, AGND22, 3V3_EXT, VCC, TIMER, SS, PG, OV, LOADEN, ISET, IMON, FLT, ENT, EN/UV	3A	Test point	Through-hole	Any	
2	C1, C9	1µF	Capacitor, 50V, X7R	0805	Murata	GCM21BR71H105 KA03L
5	C2, C3, C4, C7, C10	10nF	Capacitor, 25V, X7R	0603	Würth	885012206065
1	C5	1µF	Capacitor, 16V, X7R	0603	Würth	885012206052
1	C6	100nF	Capacitor, 16V, X7R	0603	Murata	GRM188R71C104 KA01D
1	C8	4.7µF	Capacitor, 16V, X5R	0603	Murata	GRM188R61C475 KAAJD
2	C11, C14	NS				
1	C12	470µF	Capacitor, 35V	Through-hole	Jianghai	CD263-35V470
1	C13	NS				
1	D1	13V	TVS diode	SMDJ13A	Concord	DO-214AB
1	D2	3A	Schottky diode	SMA	Diodes, Inc.	B330A
2	LED1, LED2	20mA	Blue LED	0805	Honglitronic	HL-PSC- 2012H203BC
4	PGND1, VOUT, VIN, PGND	30A	White connector	Through-hole	Any	
2	R1, R3	365kΩ	Film resistor, 1%	0603	Yageo	RC0603FR- 07365KL
3	R2, R4, R5	100kΩ	Film resistor, 1%	0603	Yageo	RC0603FR- 07100KL
1	R6	10kΩ	Film resistor, 1%	0603	Yageo	RC0603FR- 0710KL
2	R9, R10	4.99kΩ	Film resistor, 1%	0603	Yageo	RC0603FR- 074K99L
1	R7	12kΩ	Film resistor, 1%	0603	Yageo	RC0603FR- 0712KL
1	R8	2kΩ	Film resistor, 1%	0603	Yageo	RC0603FR-072KL
1	R11, R12	NS				

**EV5026-V-00A BILL OF MATERIALS (continued)**

Qty	Ref	Value	Description	Package	Manufacturer	Manufacturer PN
3	R13, R14, R15	0Ω	Film resistor, 1%	0603	Yageo	RC0603FR-070RL
1	SW1	0.5A	Switch	Through-hole	Wurth	450301014042
1	U1	MP5026	16V, 20A, 2.8mΩ R <sub>DS(ON)</sub> , hot-swap Intelli-Fuse	LGA-26 (4mmx4mm)	MPS	MP5026GLRT

## EVB TEST RESULTS

Performance waveforms are tested on the evaluation board.  $V_{IN} = 12V$ ,  $R_{ISET} = 12k\Omega$ ,  $R_{IMON} = 2k\Omega$ ,  $T_A = 25^\circ C$ , unless otherwise noted.

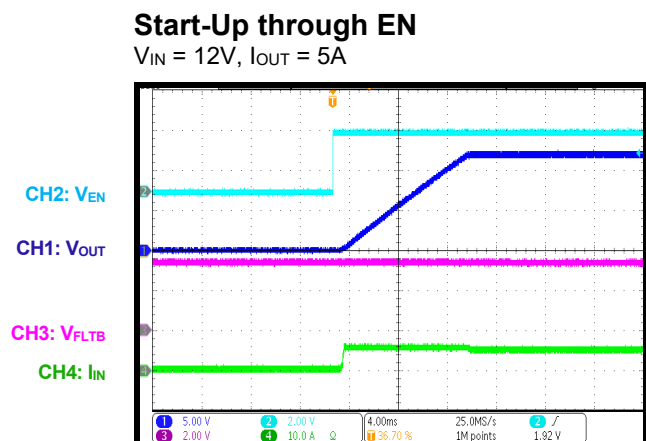
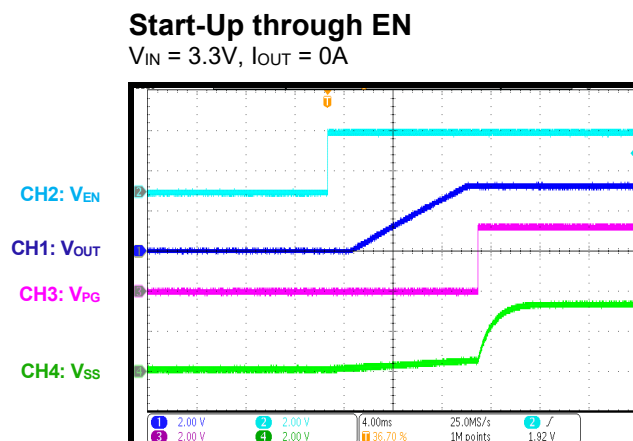
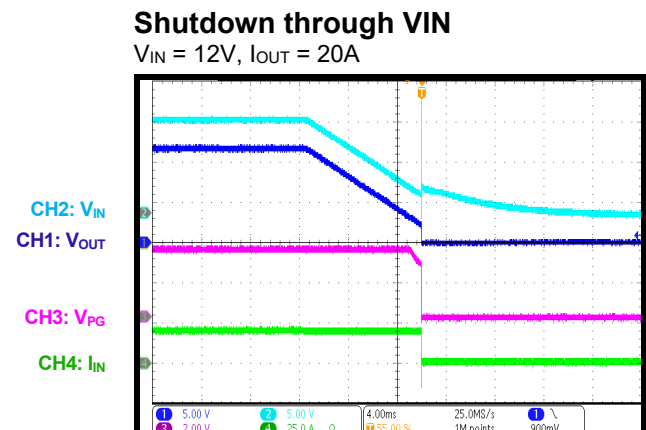
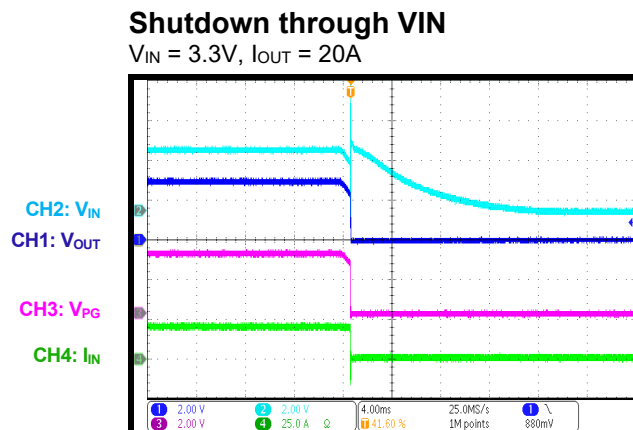
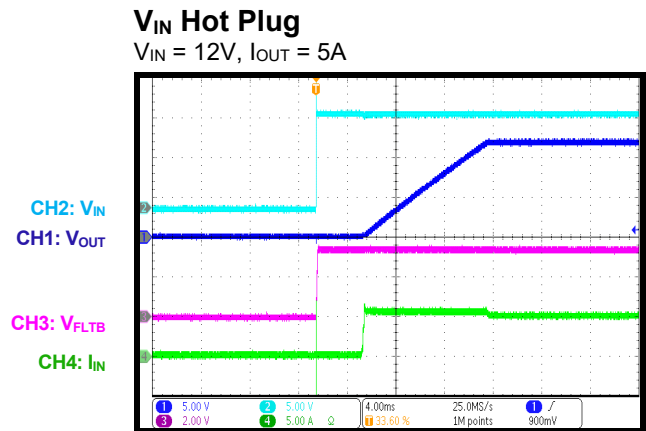
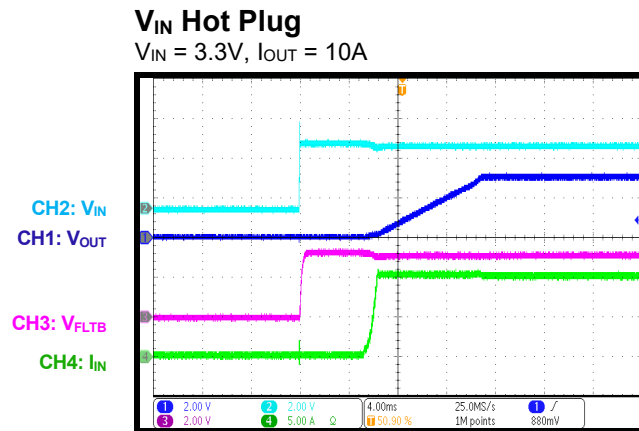

**EVB TEST RESULTS (continued)**
 $V_{IN} = 12V$ ,  $R_{ISET} = 12k\Omega$ ,  $R_{IMON} = 2k\Omega$ ,  $T_A = 25^\circ C$ , unless otherwise noted.

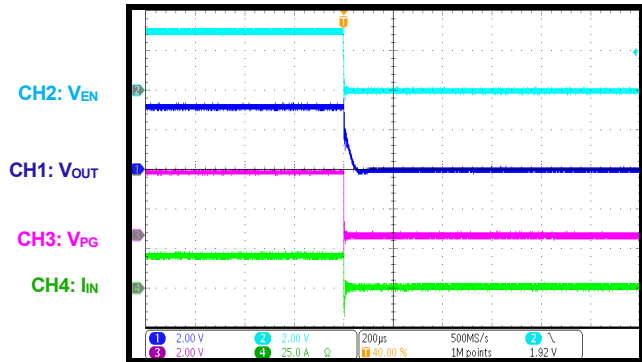
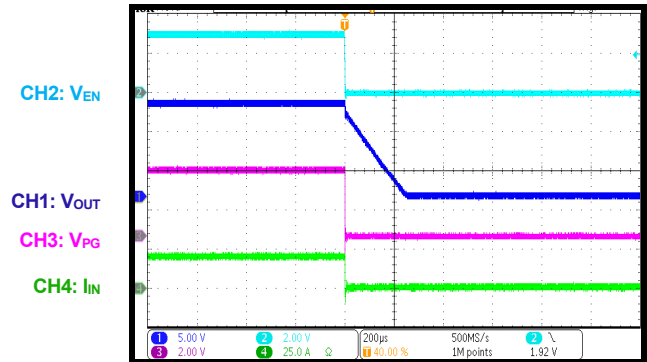
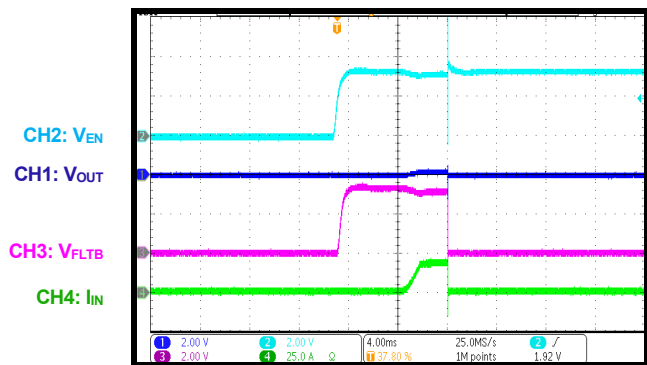
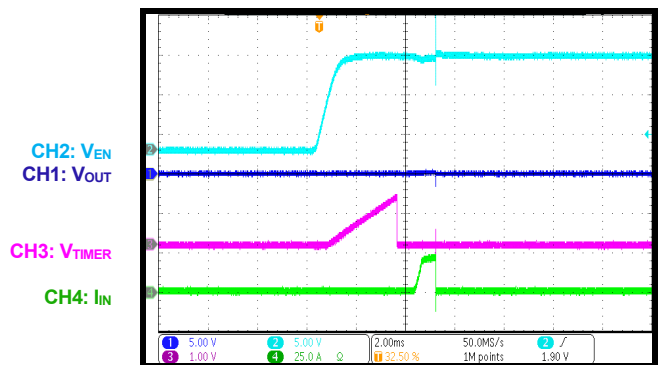
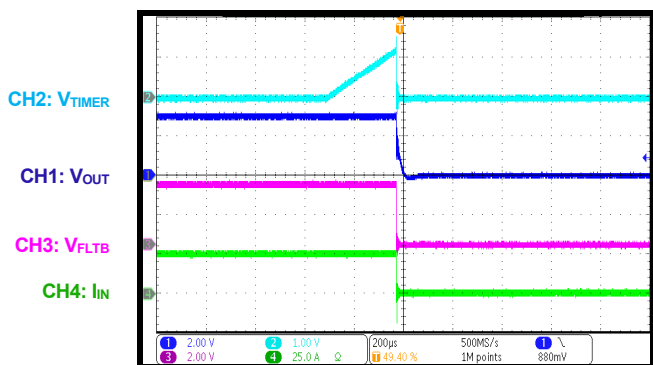
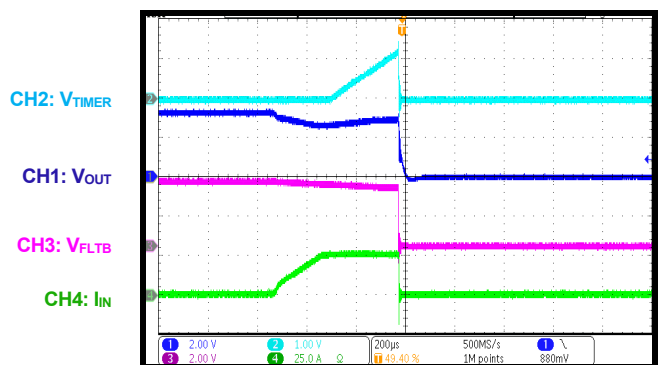
**Shutdown through EN**
 $V_{IN} = 3.3V$ ,  $I_{OUT} = 20A$ 

**Shutdown through EN**
 $V_{IN} = 12V$ ,  $I_{OUT} = 20A$ 

**Short Circuit Start-Up**
 $V_{IN} = 3.3V$ 

**Short Circuit Start-Up**
 $V_{IN} = 12V$ 

**Over-Current Protection**
 $V_{IN} = 3.3V$ , add load to 25A slowly

**Over-Current Protection**
 $V_{IN} = 3.3V$ , add load to 25A quickly



## EVB TEST RESULTS (continued)

$V_{IN} = 12V$ ,  $R_{ISET} = 12k\Omega$ ,  $R_{IMON} = 2k\Omega$ ,  $T_A = 25^\circ C$ , unless otherwise noted.

### Over-Current Protection

$V_{IN} = 12V$ , add load to 25A slowly

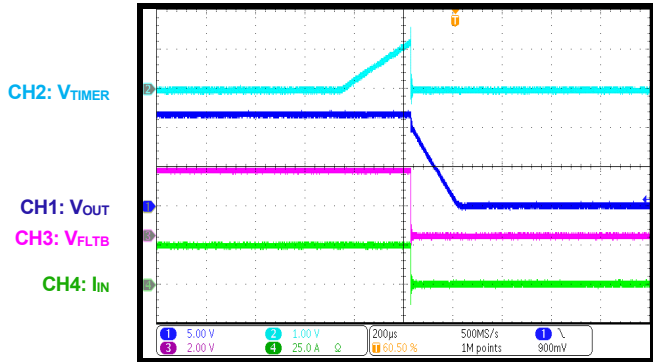

### Over-Current Protection

$V_{IN} = 12V$ , add load to 25A quickly

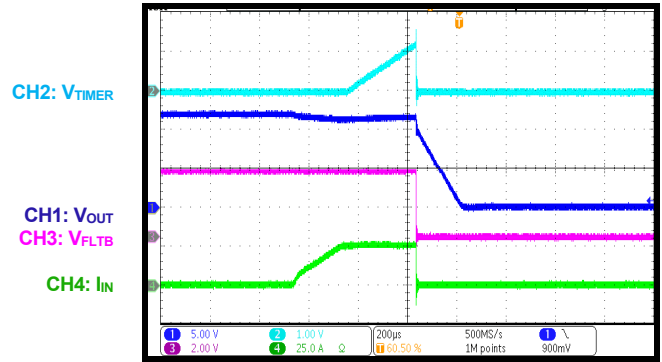

### Short-Circuit Protection

$V_{IN} = 12V$

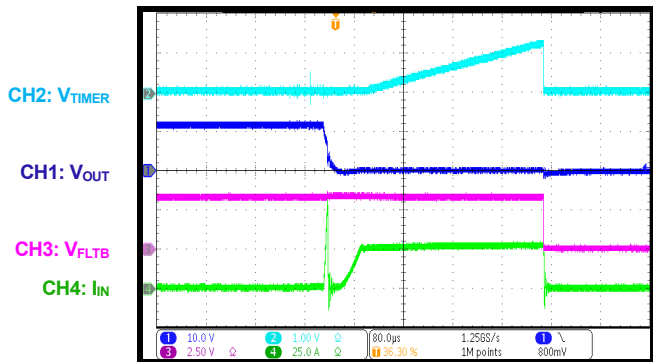

### DS Short

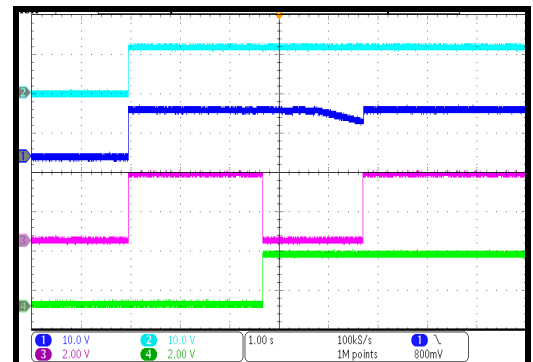

### $V_{IN}$ OVP Shutdown

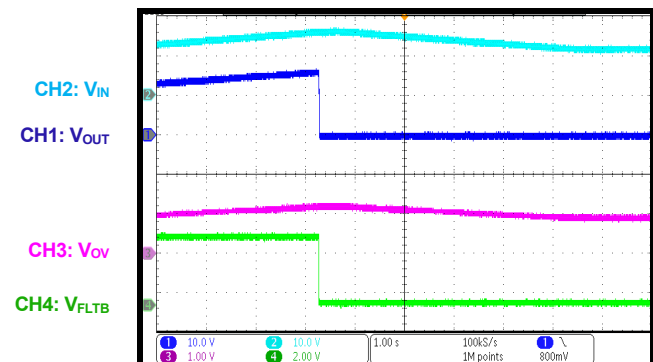

### $V_{IN}$ OVP Recovery

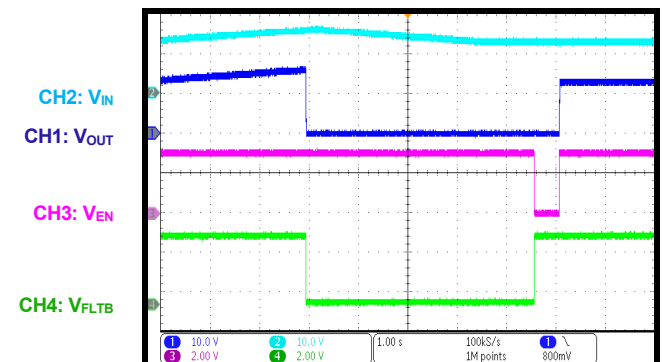

### PCB LAYOUT

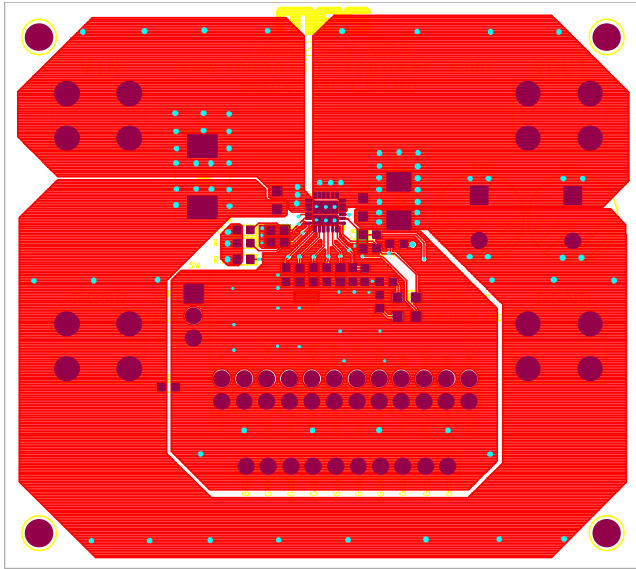

Figure 3: Top Layer

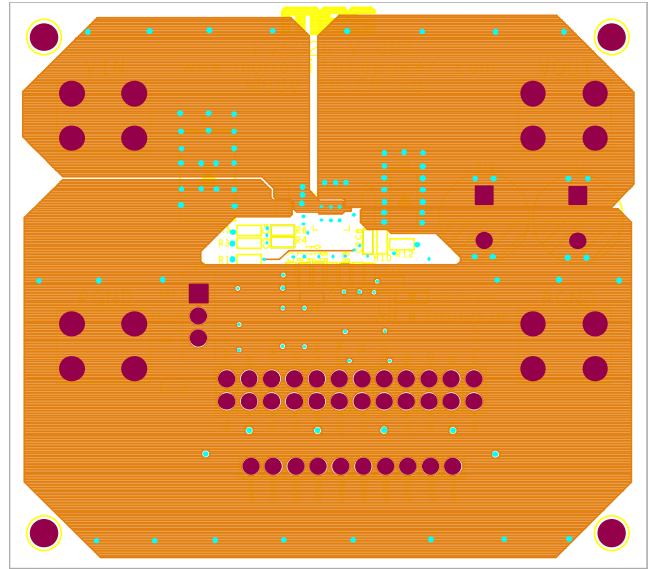

Figure 4: Mid-Layer 1

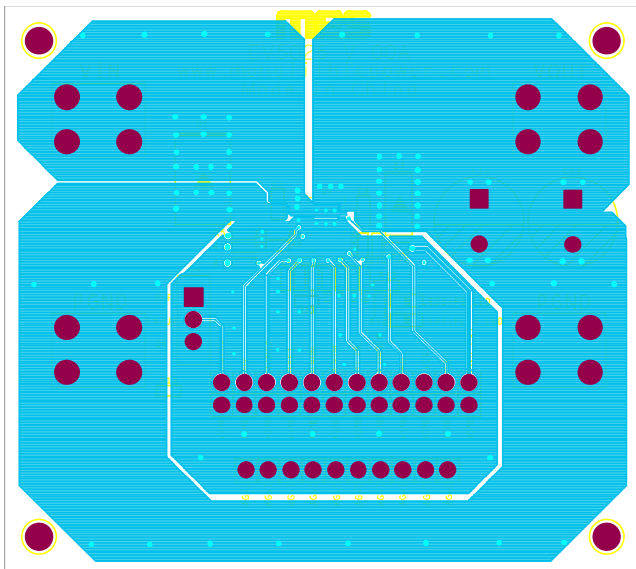

Figure 5: Mid-Layer 2

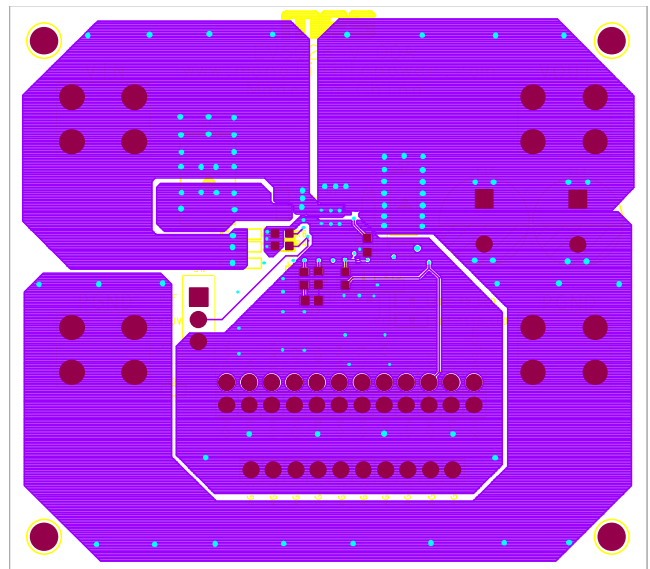

Figure 6: Bottom Layer

## REVISION HISTORY

Revision #	Revision Date	Description	Pages Updated
1.0	3/29/2024	Initial Release	-

**Notice:** The information in this document is subject to change without notice. Please contact MPS for current specifications. Users should warrant and guarantee that third-party Intellectual Property rights are not infringed upon when integrating MPS products into any application. MPS will not assume any legal responsibility for any said applications.