

**RoHS  
Compliant**

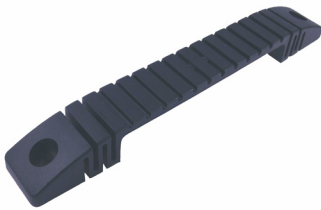

## Description

Strap Handle is a 7" long, elegant one piece moulded handle. Matt black finish. Nylon 6, highly impact modified natural material. Useable for static loads up to 15Kg.

Mechanical Properties			
Properties (DAM)	Test Method	Typical Value	Units
Tensile Strength	ISO R 527	50	MPa
Ultimate Elongation	ISO R 527	100	%
Flexural Modulus	ISO R 178	1.3	GPa
Flexural Strength	ISO R 178	55	MPa
Izod Notched Impact	ISO R 180	90	kJ/m <sup>2</sup>
Thermal Properties			
Melting Point	ISO R 75	220	°C
Heat of Deflection Temperature	0.46MPa	50	°C
	1.85MPa	145	°C
Miscellaneous			
24 Hour Moisture Absorption	ISO R 62	1.2	%
Specific Gravity	ISO R 1183	1.09	-
Mould Shrinkage	-	1.5 - 2	%
Flammability to UL94	-	HB94	Rating

## Diagram

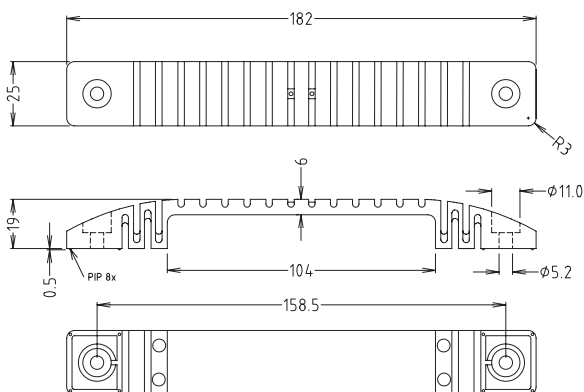

Dimensions : Millimetres

## Part Number Table

Description	Part Number
Strap Handle, 7", Matt Black Finish	MP001632

**Important Notice :** This data sheet and its contents (the "Information") belong to the members of the AVNET group of companies (the "Group") or are licensed to it. No licence is granted for the use of it other than for information purposes in connection with the products to which it relates. No licence of any intellectual property rights is granted. The Information is subject to change without notice and replaces all data sheets previously supplied. The Information supplied is believed to be accurate but the Group assumes no responsibility for its accuracy or completeness, any error in or omission from it or for any use made of it. Users of this data sheet should check for themselves the Information and the suitability of the products for their purpose and not make any assumptions based on information included or omitted. Liability for loss or damage resulting from any reliance on the Information or use of it (including liability resulting from negligence or where the Group was aware of the possibility of such loss or damage arising) is excluded. This will not operate to limit or restrict the Group's liability for death or personal injury resulting from its negligence. Multicomp Pro is the registered trademark of Premier Farnell Limited 2019.