

---

# PXle-1090

# Specifications

---

2025-03-09



# Contents

PXIe-1090 Specifications ..... 3

# PXIe-1090 Specifications

This document contains specifications for the PXIe-1090 chassis.



**Note** You will impair the protection the PXIe-1090 provides if you use it in a manner not described in this document.

## Looking For Something Else?

For information not found in the specifications for your product, such as operating instructions, browse ***Related Information***.

### Related information:

- [PXIe-1090 User Guide](#)
- [Software and Driver Downloads](#)
- [Dimensional Drawings](#)
- [Product Certifications](#)
- [Letter of Volatility](#)
- [Discussion Forums](#)
- [NI Learning Center](#)

## Chassis Components

The following figures show key features of the PXIe-1090 chassis front and back panels.

Figure 1. PXIe-1090 Front Panel Features

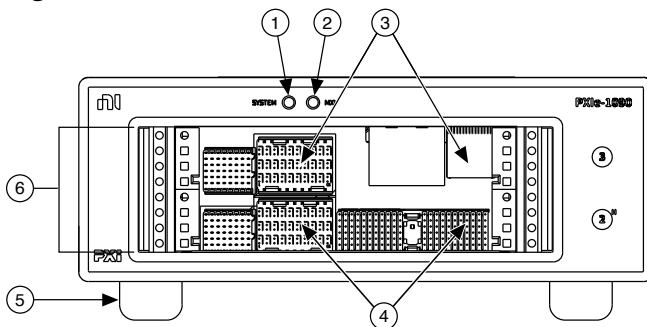

1. System LED
2. MXI LED
3. PXI Express Peripheral Slot
4. PXI Express Hybrid Peripheral Slot
5. Rubber Foot
6. Backplane Connectors

Figure 2. PXIe-1090 Back Panel Features

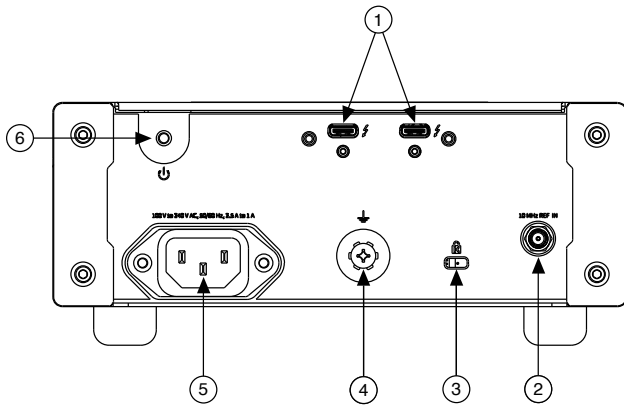

1. Thunderbolt 3 MXI-Express Ports
2. 10 MHz REF IN SMA Connector
3. Kensington Slot
4. Chassis Grounding Terminal
5. Universal AC Input
6. Power Inhibit Switch

## Electrical

The following section provides information about the PXIe-1090 AC input and DC output.

### AC Input

Input rating	100 VAC to 240 VAC, 50 Hz/60 Hz, 3 A to 1.5 A
--------------	---

Operating voltage range <sup>11</sup>	90 VAC to 264 VAC
Nominal input frequency	50 Hz/60 Hz
Operating frequency range <sup>1</sup>	47 Hz to 63 Hz
Efficiency	93.5% typical
Over-current protection	Internal fuse in line
Main power disconnect	The AC power cable provides main power disconnect. Do not position the equipment so that it is difficult to disconnect the power cord. The front-panel power switch causes the internal chassis power supply to provide DC power to the PXI Express backplane.



**Caution** Disconnect power cord to completely remove power.

## DC Output

DC output characteristics of the PXIe-1090.

1. The operating range is guaranteed by design.

Voltage Rail	Maximum Current	Load Regulation	Maximum Ripple and Noise (20 MHz BW)
+5V_AUX	0.5 A	±5%	50 mVpp
+12 V	8.0 A	±5%	120 mVpp
+5 V	2.5 A	±5%	50 mVpp
+3.3 V	6.0 A	±5%	50 mVpp
-12 V	0.25 A	±5%	120 mVpp

Maximum total available card-cage power for the PXIe-1090 is 116 W.

The maximum power available for each Thunderbolt port is 15 W (5 V/3 A).

Table 1. Backplane Slot Current Capacity

Slot	+5 V	V (I/O)	+3.3 V	+12 V	-12 V	5 V <sub>AUX</sub>
Hybrid Peripheral Slot with PXI-5 Peripheral	—	—	3 A	6 A	—	1 A
Hybrid Peripheral Slot with PXI-1 Peripheral	2.5 A	2.5 A	6 A	1 A	1 A	—



**Note** PCI V(I/O) pins in Hybrid Peripheral Slots are connected to +5 V.



**Note** The maximum power dissipated in a peripheral slot should not exceed 58 W. Refer to the **Operating Environment** section for ambient temperature considerations at 58 W.

Over-current protection	All outputs are protected from short circuit and overload. They recover and return to regulation when the overload is removed and the power is cycled.
Over-voltage protection	+3.3 V clamped at 3.7 V to 4.3 V, +5 V clamped at 5.7 V to 6.5 V, +12 V clamped at 13.4 V to 15.6 V

## Chassis Cooling

Module cooling	Forced air circulation (positive pressurization) through two 42 CFM fans
Module slot airflow direction	Bottom of module to top of module
Module intake	Right side or bottom <sup>2</sup> of chassis
Module exhaust	Left side or top <sup>2</sup> of chassis
Slot cooling capacity	58 W
Power supply cooling	Forced air circulation (positive pressurization) through one 17 CFM fan
Power supply intake	Right side or bottom <sup>2</sup> of chassis
Power supply exhaust	Left side or top <sup>2</sup> of chassis

### Minimum chassis cooling clearances

Intake	44.5 mm (1.75 in.)
Exhaust	44.5 mm (1.75 in.)

2. Optional cooling direction applies when using the PXIe-1090 in a vertical orientation.

Figure 3. PXIe-1090 Cooling Air Flow

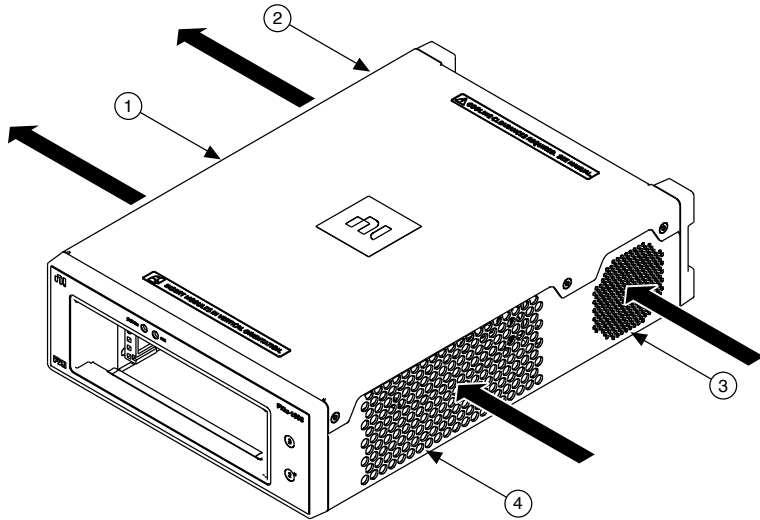

1. Module Exhaust
2. Power Supply Exhaust
3. Power Supply Intake
4. Module Intake

## Environmental

Maximum altitude	2,000 m (6,560 ft.), 800 mbar (at 25 °C ambient, high fan mode)
Pollution Degree	2

Indoor use only.

## Operating Environment

<b>Ambient temperature range</b>	
When all peripheral modules require $\leq 38$ W cooling capacity per slot	0 °C to 50 °C
When any peripheral module requires $> 38$ W to 58 W cooling capacity per slot	0 °C to 40 °C



Relative humidity range	20% to 80%, noncondensing
-------------------------	---------------------------

## Storage Environment

Ambient temperature range	-40 °C to 71 °C
Relative humidity range	10% to 95%, noncondensing

## Shock and Vibration

Operational shock	30 g peak, half-sine, 11 ms pulse
Operational random vibration	5 to 500 Hz, 0.3 grms
Non-operating vibration	5 to 500 Hz, 2.4 grms

## Acoustic Emissions

### Sound Pressure Level (at Operator Position)

<b>38 W Profile</b>	
Auto fan (up to 30 °C ambient)	32.3 dBA
High fan	44.3 dBA

58 W Profile	
Auto fan (up to 30 °C ambient)	48.9 dBA
High fan	51.4 dBA

## Sound Power Level

38 W Profile	
Auto fan (up to 30 °C ambient)	39.4 dBA
High fan	51.9 dBA

58 W Profile	
Auto fan (up to 30 °C ambient)	58.5 dBA
High fan	60.5 dBA

## Safety Compliance Standards

This product is designed to meet the requirements of the following electrical equipment safety standards for measurement, control, and laboratory use:

- IEC 61010-1, EN 61010-1
- UL 61010-1, CSA C22.2 No. 61010-1



**Note** For safety certifications, refer to the product label or the [Product Certifications and Declarations](#) section.

## EMC Guidelines

This product was tested and complies with the regulatory requirements and limits for electromagnetic compatibility (EMC) stated in the product specifications. These requirements and limits provide reasonable protection against harmful interference when the product is operated in the intended operational electromagnetic environment.

This product is intended for use in industrial locations. However, harmful interference may occur in some installations, when the product is connected to a peripheral device or test object, or if the product is used in residential areas. To minimize interference with radio and television reception and prevent unacceptable performance degradation, install and use this product in strict accordance with the instructions in the product documentation.

Furthermore, any changes or modifications to the product not expressly approved by NI could void your authority to operate it under your local regulatory rules.

## EMC Notices

Refer to the following notices for cables, accessories, and prevention measures necessary to ensure the specified EMC performance.



### Notice

For EMC declarations and certifications, and additional information, refer to the [Product Certifications and Declarations](#) section.



**Notice** Changes or modifications to the product not expressly approved by NI could void your authority to operate the product under your local regulatory rules.



**Notice** Operate this product only with shielded cables and accessories.

## Electromagnetic Compatibility Standards

This product meets the requirements of the following EMC standards for electrical equipment for measurement, control, and laboratory use:

- EN 61326-1 (IEC 61326-1): Class A emissions; Basic immunity
- EN 55011 (CISPR 11): Group 1, Class A emissions
- AS/NZS CISPR 11: Group 1, Class A emissions



**Note** Group 1 equipment (per CISPR 11) is any industrial, scientific, or medical equipment that does not intentionally generate radio frequency energy for the treatment of material or inspection/analysis purposes.



**Note** In Europe, Canada, Australia, and New Zealand (per CISPR 11) Class A equipment is intended for use in nonresidential locations.

## CE Compliance

This product meets the essential requirements of applicable European Directives, as follows:

- 2014/35/EU; Low-Voltage Directive (safety)
- 2014/30/EU; Electromagnetic Compatibility Directive (EMC)
- 2011/65/EU; Restriction of Hazardous Substances (RoHS)

## Product Certifications and Declarations

Refer to the product Declaration of Conformity (DoC) for additional regulatory compliance information. To obtain product certifications and the DoC for NI products, visit [ni.com/product-certifications](https://ni.com/product-certifications), search by model number, and click the appropriate link.

## Environmental Management

NI is committed to designing and manufacturing products in an environmentally responsible manner. NI recognizes that eliminating certain hazardous substances from

our products is beneficial to the environment and to NI customers.

For additional environmental information, refer to the ***Engineering a Healthy Planet*** web page at [ni.com/environment](http://ni.com/environment). This page contains the environmental regulations and directives with which NI complies, as well as other environmental information not included in this document.

## EU and UK Customers

-  **Waste Electrical and Electronic Equipment (WEEE)**—At the end of the product life cycle, all NI products must be disposed of according to local laws and regulations. For more information about how to recycle NI products in your region, visit [ni.com/environment/weee](http://ni.com/environment/weee).

## 电子信息产品污染控制管理办法（中国RoHS）

-  **中国RoHS**—NI符合中国电子信息产品中限制使用某些有害物质指令 (RoHS)。关于NI中国RoHS合规性信息，请登录 [ni.com/environment/rohs\\_china](http://ni.com/environment/rohs_china)。(For information about China RoHS compliance, go to [ni.com/environment/rohs\\_china](http://ni.com/environment/rohs_china).)

## Backplane

Size	3U-sized; 2 peripheral slots. Compliant with IEEE 1101.10 mechanical packaging. PXI Express Specification compliant. Accepts both PXI Express and CompactPCI (PICMG 2.0 R 3.0) 3U modules.
Backplane bare-board material	UL 94 V-0 Recognized
Backplane connectors	Conforms to IEC 917 and IEC 1076-4-101, UL 94 V-0 rated

## System Synchronization Clocks

### 10 MHz System Reference Clock: PXI\_CLK10

Maximum slot-to-slot skew	250 ps
Accuracy	±25 ppm max (guaranteed over the operating temperature range)
Maximum jitter	5 ps RMS phase-jitter (10 Hz–1 MHz range)
Duty-factor	45% to 55%
Unloaded signal swing	3.3 V ±0.3 V



**Note** For other specifications, refer to the *PXI-1 Hardware Specification*.

### 100 MHz System Reference Clock: PXIe\_CLK100 and PXIe\_SYNC100

Maximum slot-to-slot skew	100 ps
Accuracy	±25 ppm max (guaranteed over the operating temperature range)
Maximum jitter	3 ps RMS phase-jitter (10 Hz to 12 kHz range), 2 ps RMS phase-jitter (12 kHz to 20 MHz range)
Duty-factor for PXIe_CLK100	45% to 55%

Absolute differential voltage (When terminated with a 50 $\Omega$ load to 1.30 V or Thévenin equivalent)	400 mV to 1000 mV
--	-------------------



**Note** For other specifications, refer to the *PXI-5 PXI Express Hardware Specification*

## Mechanical

Dimensions (with removeable feet)	
Height	80 mm (3.2 in.)
Width	190 mm (7.5 in.)
Depth	272 mm (10.7 in.)
Dimensions (without removeable feet)	
Height	67 mm (2.6 in.)
Width	190 mm (7.5 in.)
Depth	272 mm (10.7 in.)
Weight	3.24 kg (7.15 lb)
Chassis materials	Extruded Aluminum (6063-T5, 6060-T6), Cold Rolled Steel/Stainless Steel, Santoprene, Urethane Foam, PC-ABS, PC, Polyethylene

Finish	Conductive Clear Iridite on Aluminum, Electroplated Zinc on Cold Rolled Steel
--------	---

The following figure shows the PXIe-1090 chassis dimensions. You can remove the rubber feet with a Philips screwdriver. This exposes screw threads in the exterior of the product chassis, which you can use with a mounting accessory. Consult the ***PXIe-1090 Dimensional Drawings*** for more detailed dimensional information.

Figure 4. PXIe-1090 Dimensions

