



Product Change Notification: SYST-05RWXR026

Date:

21-Mar-2025

Product Category:

Wireless Modules

Notification Subject:

Data Sheet - ATWINC15x0-MR210xB IEEE 802.11 b/g/n SmartConnect IoT Module

Affected CPNs:

[SYST-05RWXR026_Affected_CPN_03212025.pdf](#)

[SYST-05RWXR026_Affected_CPN_03212025.csv](#)

Notification Text:

SYST-05RWXR026

Microchip has released a new Datasheet for the ATWINC15x0-MR210xB IEEE 802.11 b/g/n SmartConnect IoT Module of devices. If you are using one of these devices please read the document located at [ATWINC15x0-MR210xB IEEE 802.11 b/g/n SmartConnect IoT Module](#).

Notification Status: Final

Description of Change:

Features • Removed Wi-Fi® Direct

- Added compatibility for Wi-Fi 6/7 2.4 GHz band
- Updated Superior MAC throughput
- Editorial updates

WLAN Subsystem Updated content

Description Removed HCCA

MAC Features • Removed PCF, traffic scheduling

- Removed transmission feature in Advanced IEEE 802.11n

- Editorial updates.

PHY Features Editorial updates.

Recommended External

Antenna for ATWINC15x0-

MR210UB

Removed RN-SMA-4 from Table 11-1

Receiver Performance Added note

Memory Subsystem Changed unit MB to Mb

Application Schematic • Updated Figure 9-1

- Updated notes

Module Package Drawing Updated Package drawing

Pin Description Updated Pin description and notes for WAKE Pin

Impacts to Data Sheet: See above details

Reason for Change: To Improve Productivity

Change Implementation Status: Complete

Date Document Changes Effective: 21 Mar 2025

NOTE: Please be advised that this is a change to the document only the product has not been changed.

Markings to Distinguish Revised from Unrevised Devices: N/A

Attachments:

ATWINC15x0-MR210xB IEEE 802.11 b/g/n SmartConnect IoT Module

Please contact your local [Microchip sales office](#) with questions or concerns regarding this notification.

Terms and Conditions:

If you wish to receive Microchip PCNs via email please register for our PCN email service at our [PCN home page](#) select register then fill in the required fields. You will find instructions about registering for Microchips PCN email service in the [PCN FAQ](#) section.

If you wish to change your PCN profile, including opt out, please go to the [PCN home page](#) select login and sign into your myMicrochip account. Select a profile option from

Affected Catalog Part Numbers (CPN)

ATWINC1500-MR210PB

ATWINC1500-MR210PB1140

ATWINC1500-MR210PB1172

ATWINC1500-MR210PB1944

ATWINC1500-MR210PB1952

ATWINC1500-MR210PB1952-T

ATWINC1500-MR210PB1954

ATWINC1500-MR210PB1961

ATWINC1500-MR210PB1961-T

ATWINC1500-MR210PB1965-T

ATWINC1500-MR210PB1976

ATWINC1500-MR210PB1976-T

ATWINC1500-MR210PB1977

ATWINC1500-MR210PB1977-T

ATWINC1500-MR210UB

ATWINC1500-MR210UB1140

ATWINC1500-MR210UB1944

ATWINC1500-MR210UB1954

ATWINC1500-MR210UB1961

ATWINC1500-MR210UB1961-T

ATWINC1500-MR210UB1976

ATWINC1500-MR210UB1976-T

ATWINC1500-MR210UB1977

ATWINC1500-MR210UB1977-T

ATWINC1510-MR210PB

ATWINC1510-MR210PB1140

ATWINC1510-MR210PB1944

ATWINC1510-MR210PB1952

ATWINC1510-MR210PB1954

Date: Friday, March 21, 2025

ATWINC1510-MR210PB1961
ATWINC1510-MR210PB1961-T
ATWINC1510-MR210PB1963
ATWINC1510-MR210PB1963-T
ATWINC1510-MR210PB1967
ATWINC1510-MR210PB1976
ATWINC1510-MR210PB1976-T
ATWINC1510-MR210UB
ATWINC1510-MR210UB1140
ATWINC1510-MR210UB1944
ATWINC1510-MR210UB1952
ATWINC1510-MR210UB1954
ATWINC1510-MR210UB1961
ATWINC1510-MR210UB1976
ATWINC1510-MR210UB1976-T

ATWINC15x0-MR210xB IEEE 802.11 b/g/n SmartConnect IoT Module

ATWINC15x0

www.microchip.com Product Pages: [ATWINC1500](#), [ATWINC1510](#)



Introduction

The ATWINC15x0-MR210xB is a low power consumption 802.11 b/g/n IoT (Internet of Things) module, specifically optimized for low power IoT applications. The module integrates Power Amplifier (PA), Low-Noise Amplifier (LNA), Switch, Power Management and a printed antenna or a micro co-ax (U.FL) connector for an external antenna resulting in a small form factor (21.7 x 14.7 x 2.1 mm) design. It is interoperable with various vendors' 802.11 b/g/n access points. This module provides Serial Peripheral Interface (SPI) ports to interface with a host controller.

The references to the ATWINC15x0-MR210xB module include the module devices listed in the following:

- ATWINC1500-MR210PB
- ATWINC1500-MR210UB
- ATWINC1510-MR210PB
- ATWINC1510-MR210UB

Features

- IEEE 802.11 b/g/n, Single Stream (1x1) 20 MHz Bandwidth WLAN Link
 - Compatible with Wi-Fi[®] 6/7 2.4 GHz band
- Single Spatial Stream in 2.4 GHz ISM Band
- Integrated Transmit/Receive Switch
- Integrated PCB Antenna or U.FL micro co-ax Connector for External Antenna
- Superior Sensitivity and Range via Advanced PHY Signal Processing
- Advanced Equalization and Channel Estimation
- Advanced Carrier and Timing Synchronization
- Soft-AP Support
- Supports IEEE 802.11 WEP, WPA, WPA2 Security
- Support Enterprise Security with WPA/WPA2 (802.1X)⁽¹⁾
 - EAP-TLS
 - EAP-PEAPv0/1 with TLS
 - EAP-TTLSv0 with MSCHAPv2
 - EAP-PEAPv0/1 with MSCHAPv2
- Superior MAC Throughput Through Hardware Accelerated Aggregate A-MPDUs/A-MDSU Frame Reception and Block Acknowledgment
- On-chip Memory Management Engine to Reduce Host Load
- SPI Host Interface

- Operating Temperature Range from -40°C to +85°C. RF Performance at Room Temperature of 25°C with a 2-3 dB Change at Boundary Conditions
- Power supply for I/O (VDDIO) Ranges from 2.7V to 3.6V
- Power Supply for DC/DC Converter (VBAT) Ranges from 3.0V to 4.2V
- Built-in 26 MHz Crystal
- Integrated Flash Memory for System Software
- Power Save Modes
 - 4 μ A Power-Down mode typical at 3.3V I/O
 - 380 μ A Doze mode with chip settings preserved (used for beacon monitoring) ⁽²⁾
 - On-chip low power sleep oscillator
 - Fast host wake-up from Doze mode by a pin or SPI transaction
- Fast Boot Options
 - On-chip boot ROM (Firmware instant boot)
 - SPI flash boot
 - Low-leakage on-chip memory for state variables
 - Fast AP re-association (150 ms)
- On-Chip Network Stack to Offload MCU
 - Network features TCP, UDP, DHCP, ARP, HTTP, TLS and DNS
 - Hardware accelerators for Wi-Fi and TLS security to improve connection time
- Hardware Accelerator for IP Checksum
- Hardware Accelerators for OTA Security
- Small Footprint Host Driver
- Wi-Fi Alliance[®] Certifications for Connectivity and Optimizations
 - ID: [WFA61069](#)

Notes:

1. For more information on the software features, refer to the *Wi-Fi Network Controller Software Design Guide* at ww1.microchip.com/downloads/en/DeviceDoc/00002389A.pdf.
2. For more information on the module power modes, refer to [Power Consumption](#).

Table of Contents

1. Ordering Information and Module Marking.....	5
2. Functional Overview.....	6
2.1. Block Diagram.....	6
2.2. Pin Description.....	6
3. Electrical Specifications.....	9
3.1. Absolute Maximum Ratings.....	9
3.2. Recommended Operating Conditions.....	9
3.3. DC Electrical Characteristics.....	9
3.4. Receiver Performance.....	10
3.5. Transmitter Performance.....	12
3.6. SPI Timing Characteristics.....	12
4. CPU and Memory Subsystems.....	14
4.1. Processor.....	14
4.2. Memory Subsystem.....	14
4.3. Nonvolatile Memory (eFuse).....	14
5. WLAN Subsystem.....	16
5.1. MAC.....	16
5.2. PHY.....	17
5.3. Radio.....	17
6. External Interfaces.....	19
6.1. Interfacing with the Host Microcontroller.....	19
6.2. SPI Client Interface.....	20
6.3. UART Interface	21
6.4. GPIO Pins.....	21
7. Power Consumption.....	23
7.1. Description of Device States.....	23
7.2. Current Consumption in Various Device States.....	23
7.3. Restrictions for Power States.....	23
7.4. Power-up/down Sequence.....	24
7.5. Digital I/O Pin Behavior During Power-up Sequences.....	24
7.6. Module Reset.....	25
8. Notes On Interfacing to the ATWINC15x0-MR210xB.....	26
8.1. Programmable Pull-Up Resistors.....	26
9. Schematic Design Information.....	27
9.1. Application Schematic.....	27
10. Module Package Drawing.....	28
10.1. Module Footprint.....	30
11. Design Considerations.....	31
11.1. ATWINC15x0-MR210PB Placement and Routing Guidelines.....	31

11.2. Printed PCB Antenna Performance of ATWINC15x0-MR210PB.....	32
11.3. ATWINC15x0-MR210UB Placement and Routing Guidelines.....	35
11.4. Recommended External Antenna for ATWINC15x0-MR210UB.....	36
11.5. Module Assembly Considerations.....	37
11.6. Conformal Coating.....	38
11.7. Reflow Profile Information.....	38
12. Regulatory Approval.....	39
12.1. United States.....	40
12.2. Canada.....	42
12.3. Europe.....	44
12.4. Japan.....	45
12.5. Korea.....	46
12.6. Taiwan.....	46
12.7. China.....	47
12.8. Brazil.....	47
12.9. Other Regulatory Information.....	49
13. Reference Documentation and Support.....	50
13.1. Reference Documentation.....	50
14. Document Revision History.....	51
Microchip Information.....	57
Trademarks.....	57
Legal Notice.....	57
Microchip Devices Code Protection Feature.....	57

1. Ordering Information and Module Marking

The following table provides the ordering information for the ATWINC15x0-MR210xB modules.

Table 1-1. Ordering Information

Model Number	Ordering Code ⁽¹⁾	Package Dimension	No. of Pins	Description	Regulatory Certification
ATWINC1500-MR210PB	ATWINC1500-MR210PBXXXX	21.7 x 14.7 x 2.1 mm	28	Certified Module with ATWINC1500B chip (4Mb Flash) and PCB printed antenna	FCC, ISED, CE, MIC, KCC, NCC, SRRC, ANATEL
ATWINC1500-MR210UB	ATWINC1500-MR210UBXXXX	21.7 x 14.7 x 2.1 mm	28	Certified Module with ATWINC1500B chip (4Mb Flash) and U.FL connector	FCC, ISED, CE, ANATEL
ATWINC1510-MR210PB	ATWINC1510-MR210PBXXXX	21.7 x 14.7 x 2.1 mm	28	Certified Module with ATWINC1510B chip (8Mb Flash) and PCB printed antenna	FCC, ISED, CE, MIC, KCC, NCC, SRRC, ANATEL
ATWINC1510-MR210UB	ATWINC1510-MR210UBXXXX	21.7 x 14.7 x 2.1 mm	28	Certified Module with ATWINC1510B chip (8Mb Flash) and U.FL connector	FCC, ISED, CE, ANATEL

Note:

- XXXX in the Ordering Code represents the Firmware version of the product. For more details, refer to the *Software Release Notes* available on the [Microchip web page](#).

The following figure illustrates the ATWINC15x0-MR210xB modules' marking information.

Figure 1-1. Marking Information

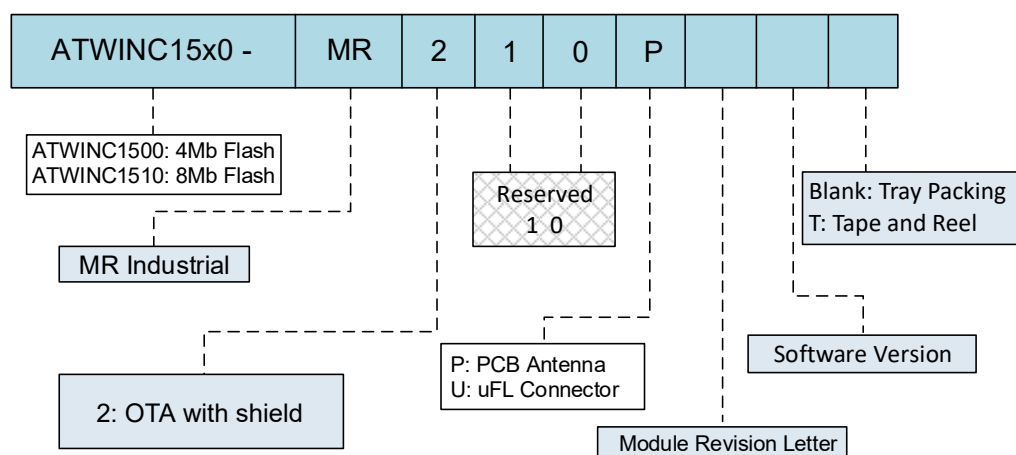

2. Functional Overview

2.1 Block Diagram

The following figure illustrates the ATWINC15x0 block diagram.

Figure 2-1. ATWINC15x0-MR210xB Module Block Diagram

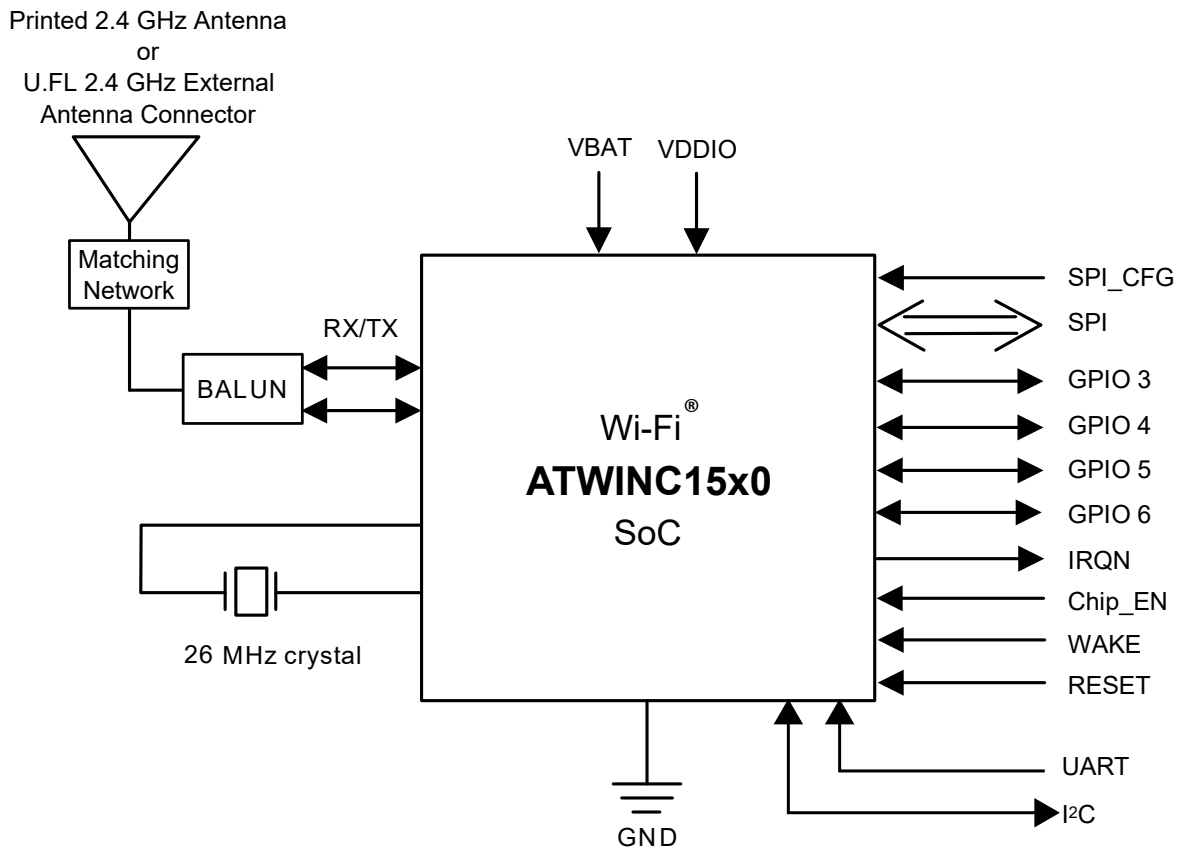

2.2 Pin Description

The following figure illustrates the ATWINC15x0-MR210xB module pin out. This module has an exposed ground pad that must be connected to the system board ground.

Figure 2-2. Pin Diagram

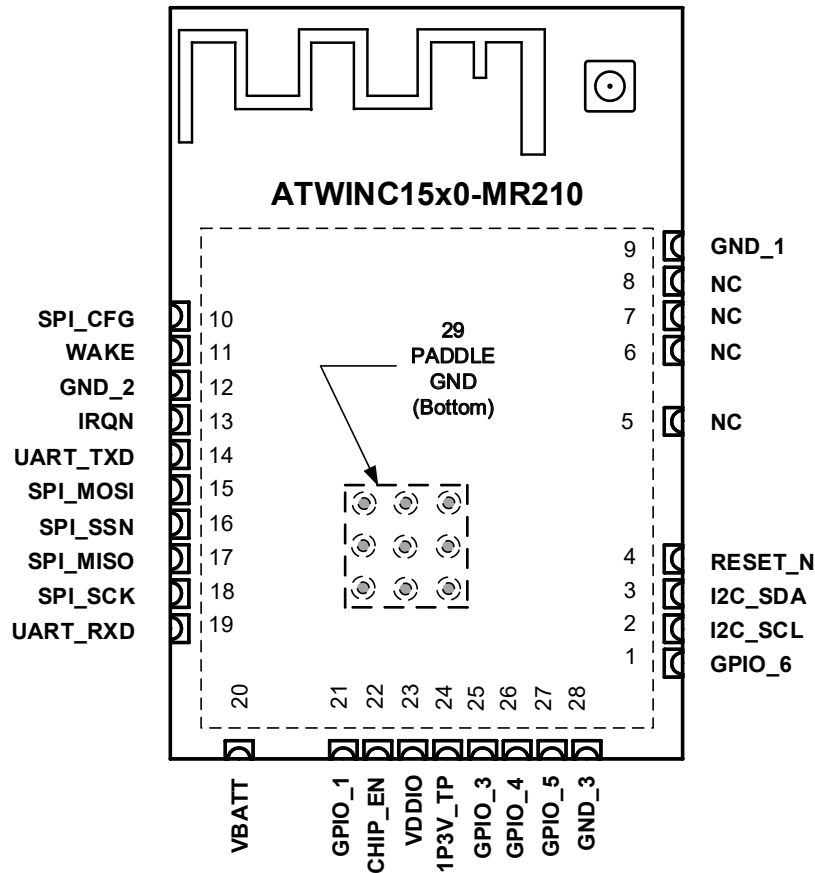

Table 2-1. ATWINC15x0-MR210xB Pin Description

Pin #	Name	Type	Description	Programmable Pull-up Resistor
1	GPIO_6	I/O	General purpose I/O ⁽¹⁾	Yes
2	I2C_SCL	I/O	I ² C Client Clock. Currently used only for development debugging. Leave unconnected. It is recommended to add Test Point to this pin.	Yes
3	I2C_SDA	I/O	I ² C Client Data. Currently used only for development debugging. Leave unconnected. It is recommended to add Test Point to this pin.	Yes
4	RESET_N	I	Active-Low Hard Reset. When this pin is asserted low, the module is set to the Reset state. When this pin is asserted high, the module comes out of Reset and functions normally. Connect to a host output that defaults low at power up. If the host output is tri-stated, add a 1 M Ω pull-down resistor to ensure a low level at power-up.	No
5	NC	—	No connect	—
6	NC	—	No connect	—
7	NC	—	No connect	—
8	NC	—	No connect	—
9	GND_1	—	GND	—
10	SPI_CFG	I	Tie to VDDIO through a 1 M Ω resistor to enable the SPI interface.	No

Table 2-1. ATWINC15x0-MR210xB Pin Description (continued)

Pin #	Name	Type	Description	Programmable Pull-up Resistor
11	WAKE	I	Host Wake control ⁽²⁾	Yes
12	GND_2	—	GND	—
13	IRQN	O	ATWINC15x0-MR210xB Device Interrupt output. Connect to host interrupt input pin.	Yes
14	UART_TXD	O	UART Transmit Output from ATWINC15x0-MR210xB Added for debugging and testing only.	Yes
15	SPI_MOSI	I	SPI MOSI (Host Out, Client In) pin	Yes
16	SPI_SSN	I	SPI Client Select. Active-low.	Yes
17	SPI_MISO	O	SPI MISO (Host In, Client Out) pin	Yes
18	SPI_SCK	I	SPI Clock	Yes
19	UART_RXD	I	UART Receive input to ATWINC15x0-MR210xB Added for debugging and testing only.	Yes
20	VBATT	—	Battery power supply	—
21	GPIO_1	I	General Purpose I/O ⁽¹⁾	Yes
22	CHIP_EN	I	Module enable. High level enables the module; low level places the module in Power-Down mode. Connect to a host output that defaults low at power-up. If the host output is tri-stated, add a 1 M Ω pull-down resistor to ensure a low level at power-up.	No
23	VDDIO	—	I/O Power Supply. Must match the host I/O voltage.	—
24	1P3V_TP	—	1.3V VDD Core Test Point. Decouple with the 10 μ F and 0.01 μ F to the GND. Close to the pin.	—
25	GPIO_3	I/O	General purpose I/O ⁽¹⁾	Yes
26	GPIO_4	I/O	General purpose I/O ⁽¹⁾	Yes
27	GPIO_5	I/O	General purpose I/O ⁽¹⁾	Yes
28	GND_3	—	GND	—
29	PADDLE GND	—	GND	—

Note:

1. Usage of the GPIO functionality is not supported by the ATWINC15x0 firmware. The data sheet will be updated when the support for this feature is added.
2. While the current firmware implementation wakes the ATWINC device through the SPI interface, it is recommended that the WAKE pin is connected to a host I/O pin for possible future use.

3. Electrical Specifications

3.1 Absolute Maximum Ratings

Absolute maximum ratings for the ATWINC15x0-MR210xB modules are listed below.

Table 3-1. Conditions

Symbol	Description	Min.	Max.	Unit
VBATT	Input supply voltage	-0.3	5.0	V
VDDIO	I/O voltage	-0.3	5.0	V
Operating Temperature	—	-40	+85	°C



Stresses listed under "**Absolute Maximum Ratings**" may cause permanent damage to the device. This is a stress rating only. The functional operation of the device at those or any other conditions above those indicated in the operation listings of this specification is not implied. Exposure to the maximum rating conditions for extended periods may affect the device's reliability.

3.2 Recommended Operating Conditions

Table 3-2. Recommended Operating Conditions

Symbol	Min.	Typ.	Max.	Unit
VBATT	3.0	3.3	4.2	V
VDDIO	2.7	3.3	3.6	V

3.3 DC Electrical Characteristics

The following table provides the DC characteristics for the ATWINC15x0-MR210xB digital pads.

Table 3-3. ATWINC15x0-MR210xB Electrical Characteristics

Characteristic	Min.	Typ.	Max.	Unit
Input low voltage (V_{IL})	-0.30	—	0.65	V
Input high voltage (V_{IH})	VDDIO-0.60	—	VDDIO+0.30	
Output low voltage (V_{OL})	—	—	0.45	
Output high voltage (V_{OH})	VDDIO-0.50	—	—	
Output loading	—	—	20	pF
Digital input load	—	—	6	
Pad drive strength (regular pads ⁽¹⁾)	8	13.5	—	mA
Pad drive strength (high-drive pads ⁽¹⁾)	16	27	—	

Note:

1. The I2C_SCL and I2C_SDA are high-drive pads and all other pads are regular.

3.3.1 Current Consumption in Various Device States

The following table provides the current consumption of ATWINC15x0-MR210xB in various device states.

Table 3-4. ATWINC15x0-MR210xB Current Consumption

Device State	Code Rate	Output Power, dBm	Current Consumption ⁽¹⁾	
			IVBATT	IVDDIO
ON_Transmit	802.11b 1 Mbps	17.5	268 mA	22 mA
	802.11b 11 Mbps	18.5	264 mA	22 mA
	802.11g 6 Mbps	17.5	269 mA	22 mA
	802.11g 54 Mbps	16.0	266 mA	22 mA
	802.11n MCS 0	17.0	268 mA	22 mA
	802.11n MCS 7	14.5	265 mA	22 mA
ON_Receive	802.11b 1 Mbps	N/A	61 mA	22 mA
	802.11b 11 Mbps	N/A	61 mA	22 mA
	802.11g 6 Mbps	N/A	61 mA	22 mA
	802.11g 54 Mbps	N/A	61 mA	22 mA
	802.11n MCS 0	N/A	61 mA	22 mA
	802.11n MCS 7	N/A	61 mA	22 mA
ON_Doze	N/A	N/A	380 μ A	<10 μ A
Power_Down	N/A	N/A	<0.5 μ A	<3.5 μ A

Note:

1. Conditions: VBATT =3.3V, VDDIO=3.3V and at 25°C

3.4 Receiver Performance

Table 3-5. Receiver Performance

Parameter	Description	Minimum	Typical	Maximum	Unit
Frequency	—	2,412	—	2,484	MHz

Table 3-5. Receiver Performance (continued)

Parameter	Description	Minimum	Typical	Maximum	Unit
Sensitivity 802.11b	1 Mbps DSS	—	-95	—	dBm
	2 Mbps DSS	—	-90	—	
	5.5 Mbps DSS	—	-92	—	
	11 Mbps DSS	—	-86	—	
Sensitivity 802.11g	6 Mbps OFDM	—	-90	—	
	9 Mbps OFDM	—	-89	—	
	12 Mbps OFDM	—	-88	—	
	18 Mbps OFDM	—	-85	—	
	24 Mbps OFDM	—	-83	—	
	36 Mbps OFDM	—	-80	—	
	48 Mbps OFDM	—	-76	—	
Sensitivity 802.11n (BW=20 MHz)	54 Mbps OFDM	—	-74	—	
	MCS 0	—	-89	—	
	MCS 1	—	-87	—	
	MCS 2	—	-85	—	
	MCS 3	—	-82	—	
	MCS 4	—	-77	—	
	MCS 5	—	-74	—	
	MCS 6	—	-72	—	
Maximum Receive Signal Level	MCS 7	—	-70.5	—	
	1-11 Mbps DSS	—	0	—	
	6-54 Mbps OFDM	—	0	—	
Adjacent Channel Rejection	MCS 0-7	—	0	—	
	1 Mbps DSS (30 MHz offset)	—	50	—	
	11 Mbps DSS (25 MHz offset)	—	43	—	
	6 Mbps OFDM (25 MHz offset)	—	40	—	
	54 Mbps OFDM (25 MHz offset)	—	25	—	
	MCS 0-20 MHz BW (25 MHz offset)	—	40	—	
Cellular Blocker Immunity	MCS 7-20 MHz BW (25 MHz offset)	—	20	—	
	776-794 MHz CDMA	—	-14	—	
	824-849 MHz GSM	—	-10	—	
	880-915 MHz GSM	—	-10	—	
	1710-1785 MHz GSM	—	-15	—	
	1850-1910 MHz GSM	—	-15	—	
	1850-1910 MHz WCDMA	—	-24	—	
1920-1980 MHz WCDMA	—	-24	—		

Note:

- Receiver sensitivity is measured in the Test mode condition on a conducted RF test setup.

3.5 Transmitter Performance

Table 3-6. Transmitter Performance^(3, 4, 5, 6, 7)

Parameter	Description	Minimum	Typical	Maximum	Unit
Frequency	—	2,412	—	2,484	MHz
Output Power ^(1, 2) ON_Transmit	802.11b 1 Mbps	—	13.6	—	dBm
	802.11b 11 Mbps	—	15.3	—	
	802.11g 6 Mbps	—	18.9	—	
	802.11g 54 Mbps	—	14.3	—	
	802.11n MCS 0	—	18.9	—	
	802.11n MCS 7	—	12.2	—	
TX Power Accuracy	—	—	±1.5 ⁽²⁾	—	dB
Carrier Suppression	—	—	30.0	—	dBc
Harmonic Output Power	2nd	—	—	-41	dBm/MHz
	3rd	—	—	-41	

Notes:

- Measured at 802.11 spec compliant EVM/Spectral Mask.
- Measured at balun output.
- Operating temperature range is -40°C to +85°C. RF performance is ensured at a room temperature of 25°C with a 2-3 dB change at boundary conditions.
- With respect to TX power, different (higher/lower) RF output power settings may be used for specific antennas and/or enclosures, in which case recertification may be required.
- The availability of some specific channels and/or operational frequency bands are country dependent and must be programmed at the host product factory to match the intended destination. Regulatory bodies prohibit exposing the settings to the end user. This requirement needs to be taken care of via host implementation.
- The RF parameters for the ATWINC15x0-MR210UB is reduced approximately by 1 dB. This insertion loss accounts for PCB trace loss and a filter network to RF U.FL connector.
- For more details on the I²C Client interface, refer to 6.1 "I²C Client Interface" from the *ATWINC15x0B-MU IEEE® 802.11 b/g/n Network Controller SoC Datasheet (DS70005374)*.

3.6 SPI Timing Characteristics

The SPI timing is provided in the following figure and table.

Figure 3-1. SPI Timing Diagram (SPI Mode CPOL = 0, CPHA = 0)

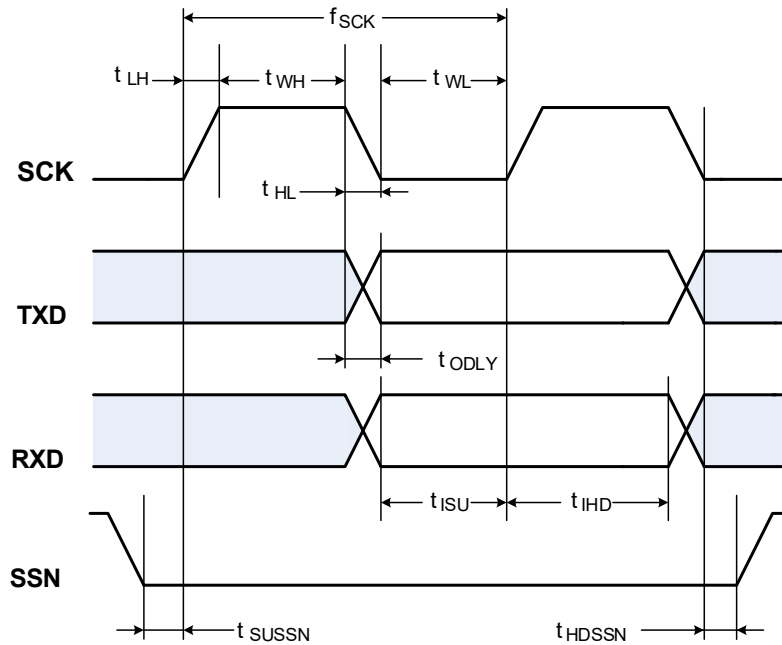

Table 3-7. SPI Client Timing Parameters⁽¹⁾

Parameter	Symbol	Min.	Max.	Units
Clock Input Frequency ⁽²⁾	f_{SCK}	—	48	MHz
Clock Low Pulse Width	t_{WL}	4	—	ns
Clock High Pulse Width	t_{WH}	5	—	
Clock Rise Time	t_{LH}	0	7	
Clock Fall Time	t_{HL}	0	7	
TXD Output Delay ⁽³⁾	t_{ODLY}	4	9 from SCK fall	
RXD Input Setup Time	t_{ISU}	1	—	
RXD Input Hold Time	t_{IHD}	5	—	
SSN Input Setup Time	t_{SUSSN}	3	—	
SSN Input Hold Time	t_{HDSSN}	5.5	—	

Notes:

1. Timing is applicable to all SPI modes.
2. Maximum clock frequency specified is limited by the SPI Client interface internal design, actual maximum clock frequency can be lower and depends on the specific PCB layout.
3. Timing based on 15 pF output loading under all conditions, $t_{LH} + t_{WH} + t_{HL} + t_{WL}$ must be less than or equal to $1/f_{SCK}$.

4. CPU and Memory Subsystems

4.1 Processor

The ATWINC15x0-MR210xB modules have a Cortus APS3 32-bit processor. This processor performs many of the MAC functions, including but not limited to the association, authentication, power management, security key management and MSDU aggregation/de-aggregation. In addition, the processor provides flexibility for various modes of operation, such as STA and AP modes.

4.2 Memory Subsystem

The APS3 core uses a 128 kB instruction/boot ROM along with a 160 kB instruction RAM and a 64 kB data RAM. The ATWINC15x0-MR210xB modules come populated with either 4 Mb or 8 Mb of Flash memory depending on the module model that is ordered. This memory can be used for system software. See [Table 1-1](#) for more information. In addition, the device uses a 128 kB shared RAM, accessible by the processor and MAC, which allows the APS3 core to perform various data management tasks on the TX and RX data packets.

4.3 Nonvolatile Memory (eFuse)

The ATWINC15x0-MR210xB modules have 768 bits of nonvolatile eFuse memory that can be read by the CPU after device reset. The eFuse is partitioned into six 128-bit banks (Bank 0 – Bank 5). Each bank has the same bit map (see the following figure). The purpose of the first 108 bits in each bank is fixed and the remaining 20 bits are general-purpose software-dependent bits or reserved for future use.

Notes: If IQ Amp Used, IQ Amp Correction, IQ Pha Used and IQ Pha Correction bit fields are programmed, Bank 0 must not be programmed with any values, and only the Bank Invalid bit must be programmed. This nonvolatile one-time-programmable (OTP) memory can be used for storing the following customer-specific parameters:

- MAC address
- Calibration information (crystal frequency offset and so on)
- Other software-specific configuration parameters

Each bank can be programmed independently, which allows for several updates of the device parameters following the initial programming. For example, if the MAC address is currently programmed in Bank 2 and to update the new MAC address, perform the following steps:

1. Invalidate the contents of Bank 2 by programming the Bank Invalid bit field of Bank 2.
2. Program Bank 3 with the new MAC address along with the values of ADC Calib (if used in Bank 2), Frequency Offset (from Bank 2), IQ Amp Correction (from Bank 2) and IQ Pha Correction (from Bank 2). The Used bit field for each corresponding value bit field should also be programmed.
3. Validate the contents of Bank 3 by programming the Bank Used bit field of Bank 3.

Each bit field (i.e., MAC Address, ADC Calibration, Frequency Offset, IQ Amp Correction and IQ Pha Correction) has its corresponding Used bit field. Each Used bit field indicates the firmware that the value in the related bit field is valid. A value of '0' in the Used bit field indicates that the following bit field is invalid and a value of '1' programmed to the Used bit field indicates that the corresponding bit field is valid and can be used by firmware. By default, ATWINC15x0-MR210xB modules are programmed with the MAC address, Frequency Offset bits, IQ Amp and IQ Phase fields of Bank 2.

Figure 4-1. Bit map for ATWINC15x0-MR210xB eFuse Bank

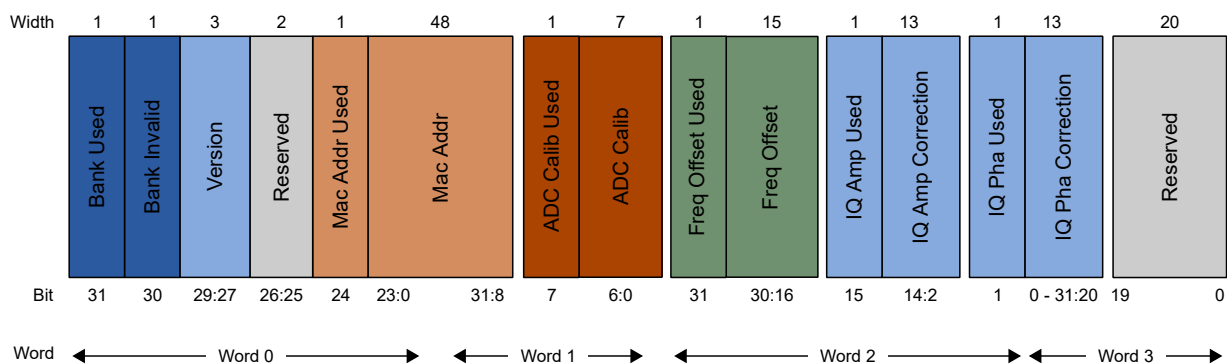

Note: The bit map has been updated with the IQ Amp correction and IQ Pha Correction fields from firmware version 19.7 onwards. Earlier these bit fields were reserved for future use. For customers using firmware older than 19.7, IQ Amp correction and IQ Pha Correction bit fields are not used by the firmware.

The matrix table below provides details on how different versions of the firmware would handle the IQ Amp used, IQ Amp correction, IQ Pha used and IQ Pha correction bit fields during Initialization.

Firmware Version Used by Customer	IQ Amp Used and IQ Pha Used Bit Status	
	Device with IQ Amp Used and IQ Pha Used Bits with Value '1'	Device with IQ Amp Used and IQ Pha Used Bits with Value '0'
19.7 or later for ATWINC15x0	Firmware loads the IQ cal values from the IQ Amp correction and IQ Pha correction bit fields of corresponding eFuse bank and proceeds with Initialization.	Firmware ignores the values in the IQ Amp correction and IQ pha correction bit fields of corresponding eFuse bank and proceeds with initialization.
Prior to 19.7 for ATWINC15x0	Firmware does not check for the IQ Amp and IQ Pha used bit fields and proceeds with Initialization.	

5. WLAN Subsystem

The WLAN subsystem is composed of the Media Access Controller (MAC), Physical Layer (PHY) including the radio.

5.1 MAC

5.1.1 Description

The ATWINC15x0-MR210xB MAC is designed to operate at low power while providing high data throughput. The IEEE 802.11 MAC functions are implemented with a combination of dedicated datapath engines, hardwired control logic and a low-power, high-efficiency microprocessor. The combination of dedicated logic with a programmable processor provides optimal power efficiency and real-time response while providing the flexibility to accommodate evolving standards and future feature enhancements.

Dedicated datapath engines are used to implement datapath functions with heavy computational requirements. For example, an FCS engine checks the CRC of the transmitting and receiving packets and a cipher engine performs all the required encryption and decryption operations for the WEP, WPA-TKIP and WPA2 CCMP-AES.

Control functions that have real-time requirements are implemented using hardwired control logic modules. These logic modules offer real-time response while maintaining configurability via the processor. Examples of hardwired control logic modules are the channel access control module (implements EDCA, Beacon TX control, interframe spacing, etc.), protocol timer module (responsible for the Network Access Vector, back-off timing, timing synchronization function and slot management), MPDU handling module, aggregation/de-aggregation module, block ACK controller (implements the protocol requirements for burst block communication) and TX/RX control FSMs (coordinate data movement between PHY-MAC interface, cipher engine and the DMA interface to the TX/RX FIFOs).

The MAC functions implemented solely in the software on the microprocessor have the following characteristics:

- Functions with high memory requirements or complex data structures. Examples are association table management and power save queuing.
- Functions with low computational load or without critical real-time requirements. Examples are authentication and association.
- Functions that need flexibility and upgradeability. Examples are beacon frame processing and QoS scheduling.

5.1.2 Features

The ATWINC15x0-MR210xB IEEE802.11 MAC supports the following functions:

- IEEE 802.11b/g/n
- IEEE 802.11e WMM QoS EDCA Multiple Access Categories.
- Advanced IEEE 802.11n Features:
 - Reception of aggregated MPDUs (A-MPDU)
 - Reception of aggregated MSDUs (A-MSDU)
 - Immediate Block Acknowledgment
 - Reduced Interframe Spacing (RIFS)
- IEEE802.11i and WFA Security with Key Management:
 - WEP 64/128

- WPA-TKIP
- 128-bit WPA2 CCMP (AES)
- Advanced Power Management:
 - Standard 802.11 Power Save Mode
- RTS-CTS and CTS-self Support
- Either STA or AP Mode in the Infrastructure Basic Service Set Mode

5.2 PHY

5.2.1 Description

The ATWINC1500B WLAN PHY is designed to achieve reliable and power-efficient physical layer communication specified by IEEE 802.11 b/g/n in single stream mode with 20MHz bandwidth. Advanced algorithms have been employed to achieve maximum throughput in a real-world communication environment with impairments and interference. The PHY implements all the required functions that include FFT, filtering, FEC (Viterbi decoder), frequency, timing acquisition and tracking, channel estimation and equalization, carrier sensing, clear channel assessment and automatic gain control.

5.2.2 Features

The ATWINC1500B IEEE802.11 PHY supports the following functions:

- Single Antenna 1x1 Stream in 20 MHz Channels
- IEEE 802.11b DSSS-CCK Modulation: 1, 2, 5.5, 11 Mbps
- IEEE 802.11g OFDM Modulation: 6, 9, 12,18, 24, 36, 48, 54 Mbps
- IEEE 802.11n HT Modulations MCS0-7, 20 MHz, 800 and 400 ns Guard Interval: 6.5, 7.2, 13.0, 14.4, 19.5, 21.7, 26.0, 28.9, 39.0, 43.3, 52.0, 57.8, 58.5, 65.0, 72.2 Mbps⁽¹⁾
- IEEE 802.11n Mixed Mode Operation
- Per Packet TX Power Control
- Advanced Channel Estimation/Equalization, Automatic Gain Control, CCA, Carrier/Symbol Recovery and Frame Detection

Note:

1. Currently, short GI is not supported by firmware. The data sheet will be updated when the feature is supported.

5.3 Radio

This section describes the properties and characteristics of the ATWINC15x0-MR210xB radio device.

The performance measurements are taken at the RF pin assuming 50Ω impedance; the RF performance is ensured at a room temperature of 25°C with a derating of 2-3 dB at boundary conditions.

Measured under the following typical conditions:

- VBATT = 3.3V
- VDDIO = 3.3V
- Temperature: +25°C

Table 5-1. Features and Properties

Feature	Description
Part Number	ATWINC15x0-MR210xB
WLAN Standard	IEEE 802.11 b/g/n, Wi-Fi compliant

Table 5-1. Features and Properties (continued)

Feature	Description
Host Interface	SPI
Dimension	21.7 x 14.7 x 2.1 mm
Frequency Range	2.412 GHz ~ 2.484 GHz (2.4 GHz ISM Band)
Number of Channels	<ul style="list-style-type: none"> • 11 for North America • 13 for Europe • 14 for Japan
Modulation	<ul style="list-style-type: none"> • 802.11b: DQPSK, DBPSK, CCK • 802.11g/n: OFDM/64-QAM, 16-QAM, QPSK, BPSK
Data Rate	802.11b: 1, 2, 5.5, 11 Mbps
	802.11g: 6, 9, 12, 18, 24, 36, 48, 54 Mbps
Data Rate (20 MHz, normal GI, 800 ns)	802.11n: 6.5, 13, 19.5, 26, 39, 52, 58.5, 65 Mbps
Data Rate (20 MHz, short GI, 400 ns) ⁽¹⁾	802.11n: 7.2, 14.4, 21.7, 28.9, 43.3, 57.8, 65, 72.2 Mbps
Operating temperature	-40 to +85°C
Storage temperature	-40 to +125°C
Humidity	<ul style="list-style-type: none"> • Operating Humidity: 10% to 95% Non-condensing • Storage Humidity: 5% to 95% Non-condensing

Note:

1. Currently, short GI is not supported by firmware. The data sheet will be updated when the feature is supported.

6. External Interfaces

The ATWINC15x0-MR210xB external interfaces include:

- I²C for debugging
- SPI for control and data transfer
- UART for debugging
- General Purpose Input/Output pins⁽¹⁾

Note:

1. Usage of the GPIO functionality is not supported by the ATWINC15x0B firmware. The data sheet will be updated once the support for this feature is added.

6.1 Interfacing with the Host Microcontroller

This section describes interfacing the ATWINC15x0-MR210xB module with the host microcontroller. The interface is comprised of a Client SPI and additional control signals, as shown in the following figure. For more information on SPI interface specification and timing, refer to the SPI Interface. Additional control signals are connected to the GPIO/IRQ interface of the microcontroller.

Figure 6-1. Interfacing with the Host Microcontroller

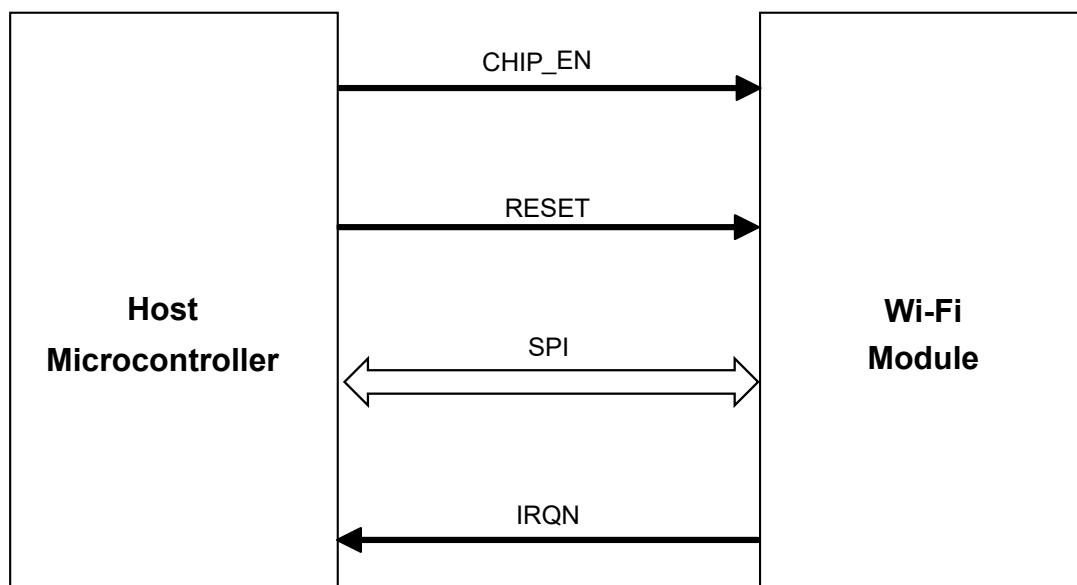

Table 6-1. Host Microcontroller Interface Pins

Pin Number	Function
4	RESET_N
13	IRQ_N
22	CHIP_EN
16	SPI_SSN
15	SPI_MOSI
17	SPI_MISO
18	SPI_SCK

Related Links

[SPI Client Interface](#)

6.2 SPI Client Interface

6.2.1 Overview

The ATWINC15x0-MR210xB has a Serial Peripheral Interface (SPI) that operates as an SPI client. The SPI interface can be used for control and for serial I/O of 802.11 data. The SPI pins are mapped as shown in the following table. The SPI is a full-duplex client-synchronous serial interface that is available immediately following reset when pin 10 (SPI_CFG) is tied to VDDIO.

Table 6-2. SPI Interface Pin Mapping

Pin #	SPI function
10	CFG: Must be tied to VDDIO
16	SSN: Active-Low Client Select
15	MOSI (RXD): Serial Data Receive
18	SCK: Serial Clock
17	MISO (TXD): Serial Data Transmit

When the SPI is not selected, that is, when SSN is high, the SPI interface will not interfere with data transfers between the serial-host and other serial-client devices. When the serial client is not selected, its transmitted data output is buffered, resulting in a high impedance drive onto the MISO line.

The SPI interface responds to a protocol that allows an external host to read or write any register in the chip as well as initiate DMA transfers.

The SPI SSN, MOSI, MISO and SCK pins of the ATWINC15x0-MR210xB have internal programmable pull-up resistors. These resistors must be programmed to be disabled; otherwise, if any of the SPI pins are driven to a low level while the ATWINC15x0-MR210xB is in the low power sleep state, the current will flow from the VDDIO supply through the pull-up resistors, increasing the current consumption of the module.

Related Links

[Programmable Pull-Up Resistors](#)

6.2.2 SPI Timing

The SPI Client interface supports four standard modes as determined by the Clock Polarity (CPOL) and Clock Phase (CPHA) settings. These modes are illustrated in the following table and figure.

Table 6-3. SPI Client Modes

Mode	CPOL	CPHA
0	0	0
1	0	1
2	1	0
3	1	1

Note: The ATWINC15x0 firmware uses “SPI MODE 0” to communicate with the host.

The red lines in the following figure correspond to Clock Phase = 0 and the blue lines correspond to Clock Phase = 1.

Figure 6-2. SPI Client Clock Polarity and Clock Phase Timing

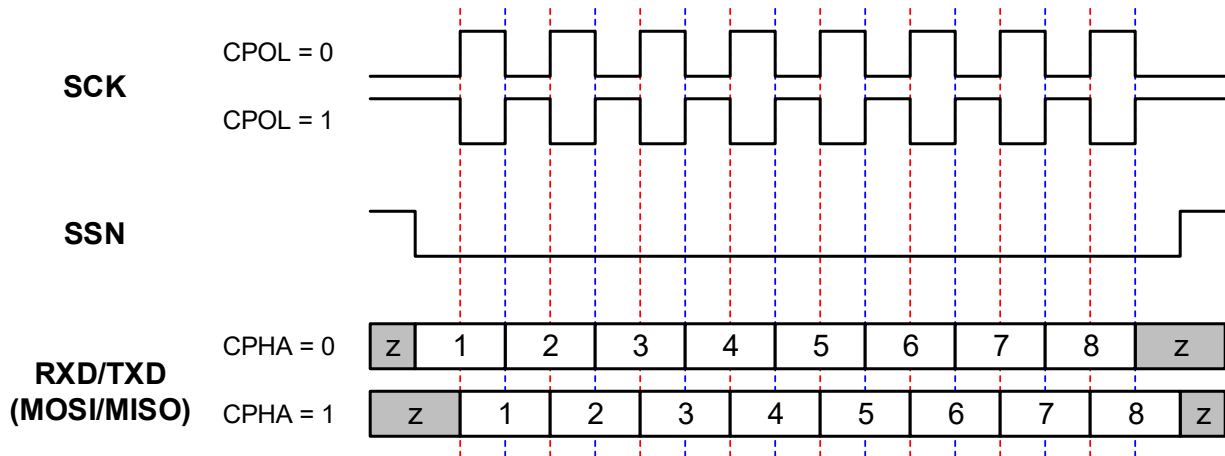

6.3 UART Interface

The ATWINC15x0-MR210xB supports the Universal Asynchronous Receiver/Transmitter (UART) interface. This interface is intended for debugging purposes only. The two UART pins TXD/RXD are available on pin J14 and pin J19, respectively. The UART is compatible with the RS-232 standard.

The default configuration for accessing the UART interface of ATWINC15x0-MR210xB is mentioned below:

- Baud rate: 460800
- Data: 8-bit
- Parity: None
- Stop bit: 1 bit
- Flow control: None

It also has RX and TX FIFOs, which ensure reliable high-speed reception and low software overhead transmission. FIFO size is 4 x 8 for both RX and TX direction. The UART also has status registers showing the number of received characters available in the FIFO and various error conditions, as well as the ability to generate interrupts based on these status bits.

An example of the UART receiving or transmitting a single packet is shown in the following figure. This example shows 7-bit data (0x45), odd parity and two stop bits.

Figure 6-3. Example of UART RX of TX Packet

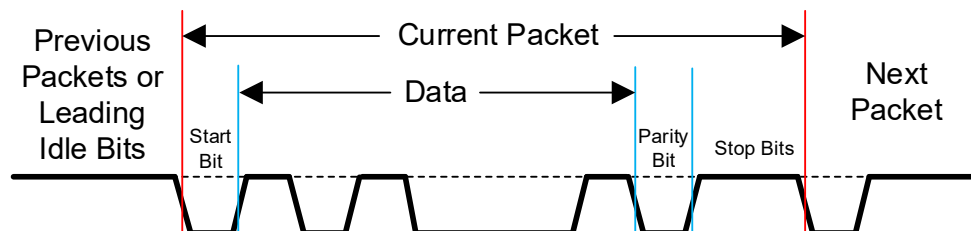

6.4 GPIO Pins

Seven General Purpose Input/Output (GPIO) pins, labeled GPIO 0 to 6, are available to allow for application specific functions. Each GPIO pin can be programmed as an input (the value of the pin can be read by the host or internal processor) or as an output (the output values can be programmed by the host or internal processor), where the default mode after power-up is input.

Note: Usage of the GPIO functionality is not supported by the WINC15x0 FW. The datasheet will be updated once the support for this feature is added.

7. Power Consumption

7.1 Description of Device States

The ATWINC15x0-MR210xB has several device states:

- ON_Transmit – Device is actively transmitting an 802.11 signal. This is the highest output power and nominal current consumption.
- ON_Receive – Device is actively receiving an 802.11 signal. This is the lowest sensitivity and nominal current consumption.
- ON_Doze – Device is ON but is neither transmitting nor receiving.
- Power_Down – Device core supply off (Leakage).
- IDLE connect – Device is connected with 1 DTIM beacon interval.

The following pins are used to switch between the ON and Power_Down states:

- CHIP_EN – Device pin (pin #22) used to enable DC/DC Converter
- VDDIO – I/O supply voltage from external supply
In the ON states, VDDIO is on and CHIP_EN is high (at VDDIO voltage level). To switch between the ON states and the Power_Down state, CHIP_EN has to change between high and low (GND) voltage. When VDDIO is off and CHIP_EN is low, the chip is powered off with no leakage (refer to [Restrictions for Power States](#)).

7.2 Current Consumption in Various Device States

Table 7-1. Current Consumption

Device State	Code Rate	Output power, dBm (1, 2)	Current Consumption ⁽¹⁾	
			IVBATT	IVDDIO
ON_Transmit	802.11b 1 Mbps	17.5	268 mA	22 mA
	802.11b 11 Mbps	18.5	264 mA	22 mA
	802.11g 6 Mbps	17.5	269 mA	22 mA
	802.11g 54 Mbps	16.0	266 mA	22 mA
	802.11n MCS 0	17.0	268 mA	22 mA
	802.11n MCS 7	14.5	265 mA	22 mA
ON_Receive	802.11b 1 Mbps	N/A	61 mA	22 mA
	802.11b 11 Mbps	N/A	61 mA	22 mA
	802.11g 6 Mbps	N/A	61 mA	22 mA
	802.11g 54 Mbps	N/A	61 mA	22 mA
	802.11n MCS 0	N/A	61 mA	22 mA
	802.11n MCS 7	N/A	61 mA	22 mA
ON_Doze	N/A	N/A	380 µA	<10 µA
Power_Down	N/A	N/A	<0.5 µA	<3.5 µA

Notes:

1. Measured conditions (Channel 6): VBATT @ 3.3V, VDDIO@ 3.3V, temp. 25°C
2. RF output power is approximately 1 dB lower for the ATWINC15x0 UB module.

7.3 Restrictions for Power States

When no power is supplied to the device, for example, the DC/DC Converter output and VDDIO are both off (at ground potential), a voltage cannot be applied to the device pins because each pin

contains an ESD diode from the pin to supply. This diode will turn on when a voltage higher than one diode drop is supplied to the pin.

If a voltage must be applied to the signal pads while the chip is in a low-power state, the VDDIO supply must be on, so the SLEEP or Power_Down state can be used.

Similarly, to prevent the pin-to-ground diode from turning on, do not apply a voltage that is more than one diode drop below the ground to any pin.

7.4 Power-up/down Sequence

The power-up/down sequence for ATWINC15x0-MR210xB is shown in the following figure. The timing parameters are shown in the following table.

Figure 7-1. Power Up/Down Sequence

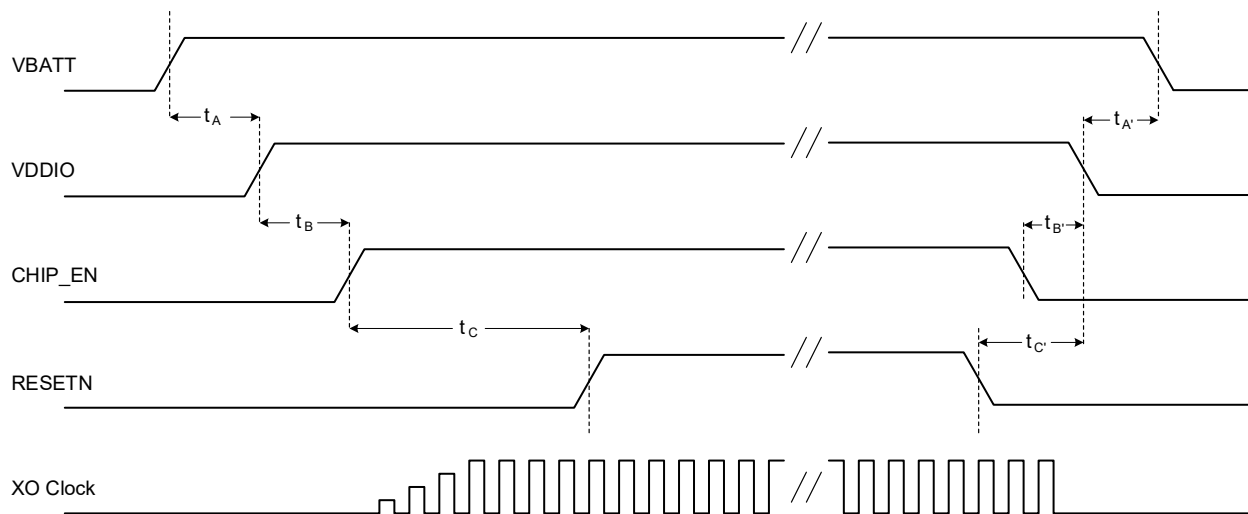

Table 7-2. Power-up/down Sequence Timing

Parameter	Min.	Max.	Units	Description	Notes
t _A	0	—	ms	VBATT rise to VDDIO rise	VBATT and VDDIO can rise simultaneously or can be tied together. VDDIO must not rise before VBATT.
t _B	0	—	ms	VDDIO rise to CHIP_EN rise	CHIP_EN must not rise before VDDIO. CHIP_EN must be driven high or low, not left floating.
t _C	5	—	ms	CHIP_EN rise to RESETN rise	This delay is needed because the XO clock must stabilize before RESETN removal. RESETN must be driven high or low, not left floating.
t _{A'}	0	—	ms	VDDIO fall to VBATT fall	VBATT and VDDIO can fall simultaneously or can be tied together. VBATT must not fall before VDDIO.
t _{B'}	0	—	ms	CHIP_EN fall to VDDIO fall	VDDIO must not fall before CHIP_EN. CHIP_EN and RESETN can fall simultaneously.
t _{C'}	0	—	ms	RESETN fall to VDDIO fall	VDDIO must not fall before RESETN. RESETN and CHIP_EN can fall simultaneously.

7.5 Digital I/O Pin Behavior During Power-up Sequences

The following table represents digital I/O pin states corresponding to device power modes.

Table 7-3. Digital I/O Pin Behavior in Different Device States

Device state	VDDIO	CHIP_EN	RESETN	Output driver	Input driver	Pull up/down resistor (96kΩ)
Power-Down: core supply off	High	Low	Low	Disabled (Hi-Z)	Disabled	Disabled
Power-on Reset: core supply on, hard reset on	High	High	Low	Disabled (Hi-Z)	Disabled	Enabled
Power-On Default: core supply on, the device is out of reset but not programmed yet	High	High	High	Disabled (Hi-Z)	Enabled	Enabled
On Sleep/ On Transmit/ On Receive: core supply on, device programmed by firmware	High	High	High	Programmed by firmware for each pin: Enabled or Disabled	Opposite of Output Driver state	Programmed by firmware for each pin: Enabled or Disabled

7.6 Module Reset

If a module reset is performed, the RESETN pin must be pulsed low for a minimum of 1μ second.

8. Notes On Interfacing to the ATWINC15x0-MR210xB

8.1 Programmable Pull-Up Resistors

The ATWINC15x0-MR210xB provides programmable pull-up resistors on various pins. The purpose of these resistors is to keep any unused input pins from floating, which can cause excess current to flow through the input buffer from the VDDIO supply. These pull-up resistors must remain enabled on any unused module pin on the ATWINC15x0-MR210xB so the pin will not float. The default state at power-up is for the pull-up resistor to be enabled. However, any pin that is used must have the pull-up resistor disabled. This is because if any pins are driven to a low level while the ATWINC15x0-MR210xB is in the low power sleep state, current will flow from the VDDIO supply through the pull-up resistors, increasing the current consumption of the module. The current through any pull-up resistor that is being driven low will be $VDDIO/100K$ because the value of the pull-up resistor is approximately 100 K Ω . For $VDDIO = 3.3V$, the current through each pull-up resistor that is driven low would be approximately $3.3V/100K = 33 \mu A$. Pins that are used and have had the programmable pull-up resistor disabled must always be actively driven to either a high or low level and not be allowed to float.

9. Schematic Design Information

This section provides schematic information for reference. Application schematics for SPI are provided in the following figure. Module design information, such as module schematics, can be obtained under an NDA from Microchip. These schematics are applicable to the ATWINC1500-MR210PB, ATWINC1510-MR210PB, ATWINC1500-MR210UB and ATWINC1510-MR210UB modules.

9.1 Application Schematic

Figure 9-1. SPI Application Schematic

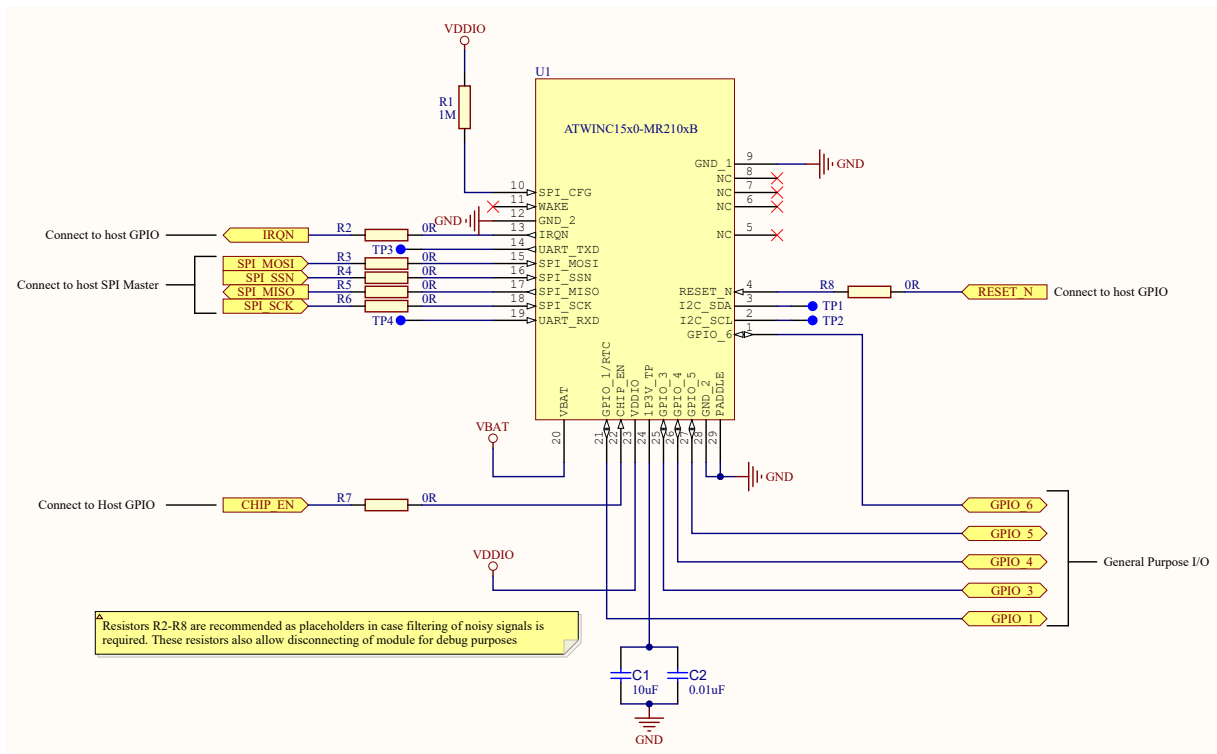

Notes:

1. Add 10 μ F and 0.01 μ F decoupling capacitors very close to pin 24 (1P3V_TP) and GND.
2. U.FL connector feature is available only in the ATWINC1500-MR210UB and ATWINC1510-MR210UB variant.
3. Add either a test point or a connector on pin 14 (UART_TXD), which is used to print the firmware debug logs.
4. Add either a test point or a connector on pin 2 (I2C_SCL) and pin 3 (I2C_SDA), which is used to connect to the MCHPRT2 Radio Test Tool through I2C Aardvark for RF testing.

10. Module Package Drawing

28-Lead PCB Module - 21.72x14.73x2.1 mm Body [Module] ATWINC15x0-MR210PB and ATWILC1000-MR110PB (Package LCB)

Note: For the most current package drawings, please see the Microchip Packaging Specification located at <http://www.microchip.com/packaging>

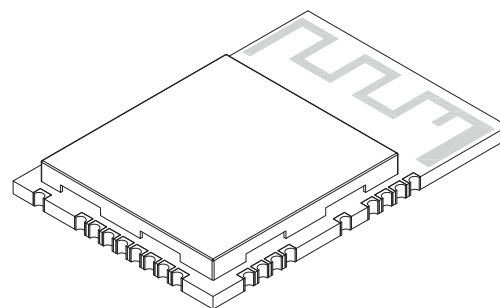
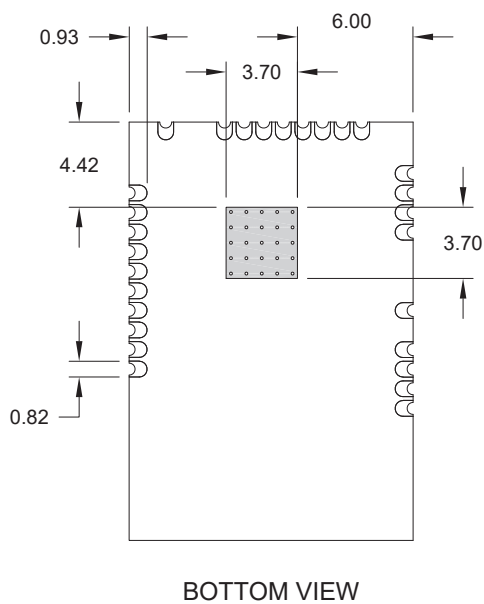
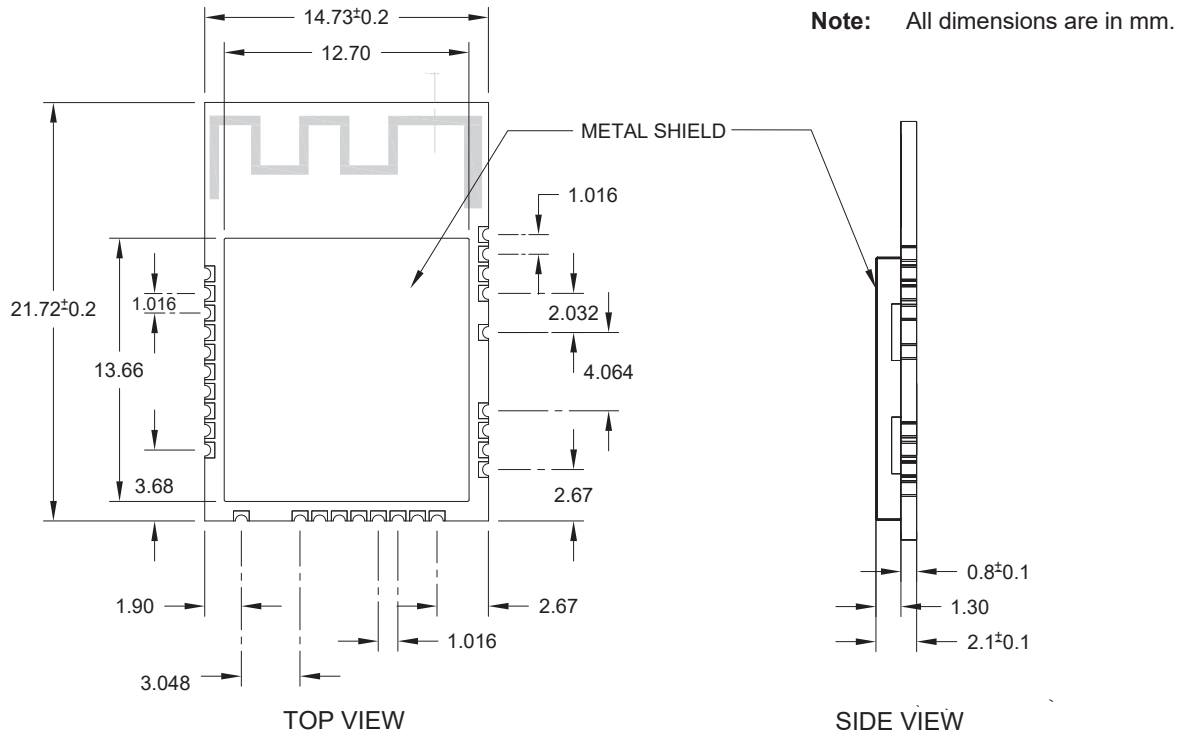

Microchip Technology Drawing C04-21305PB Rev D

**28-Lead PCB Module - 21.72x14.73x2.1 mm Body [Module]
ATWINC15x0-MR210UB and ATWILC1000-MR110UB (Package LFB)**

Note: For the most current package drawings, please see the Microchip Packaging Specification located at <http://www.microchip.com/packaging>

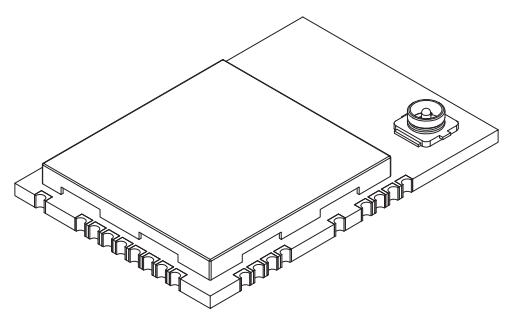
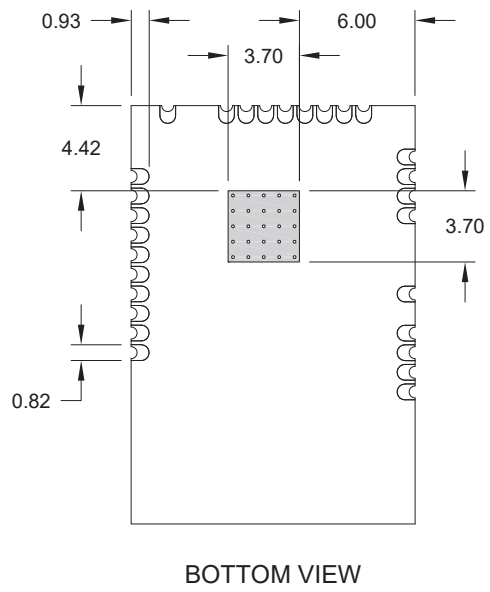
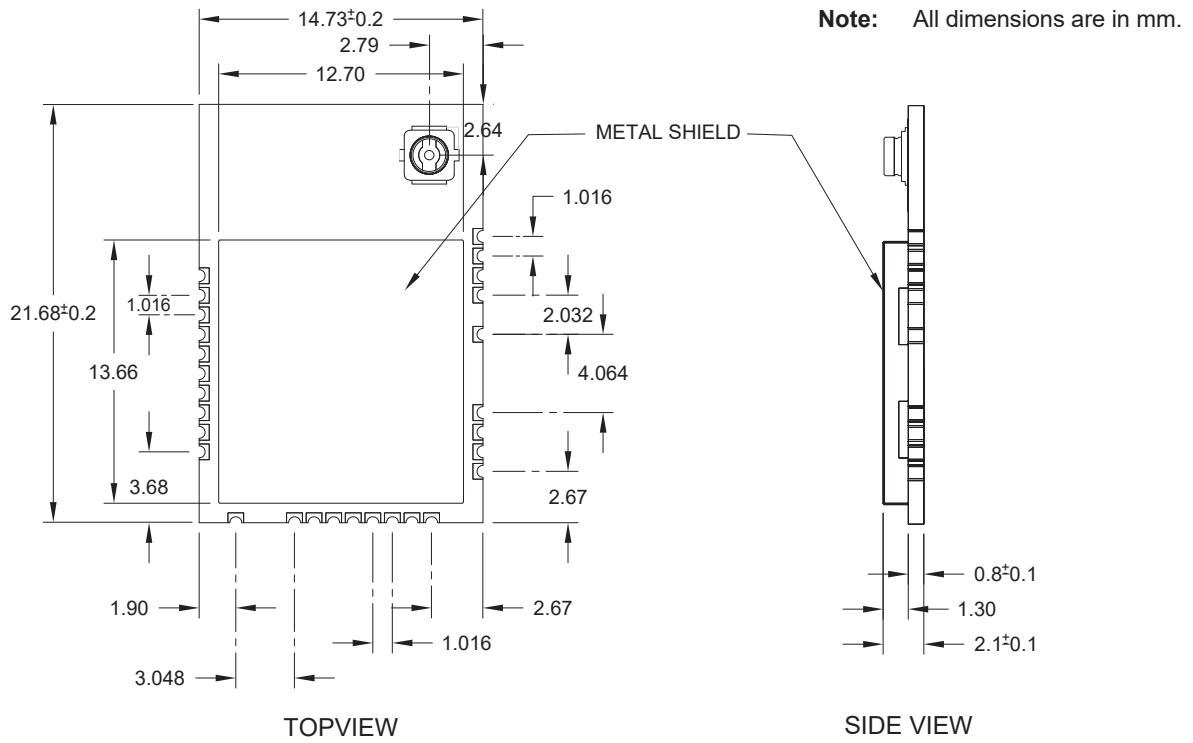

Microchip Technology Drawing C04-21305UB Rev D

10.1 Module Footprint

This section provides the outline drawing for the recommended footprint for the ATWINC15x0-MR210xB module. It is imperative that the center Ground Pad is provided with an array of vias to provide for a good ground and thermal transfer for the ATWINC15x0-MR210xB module.

This footprint is applicable to the ATWINC15x0-MR210xB module devices.

Figure 10-1. Module Solder Pad Footprint (unit = mm)

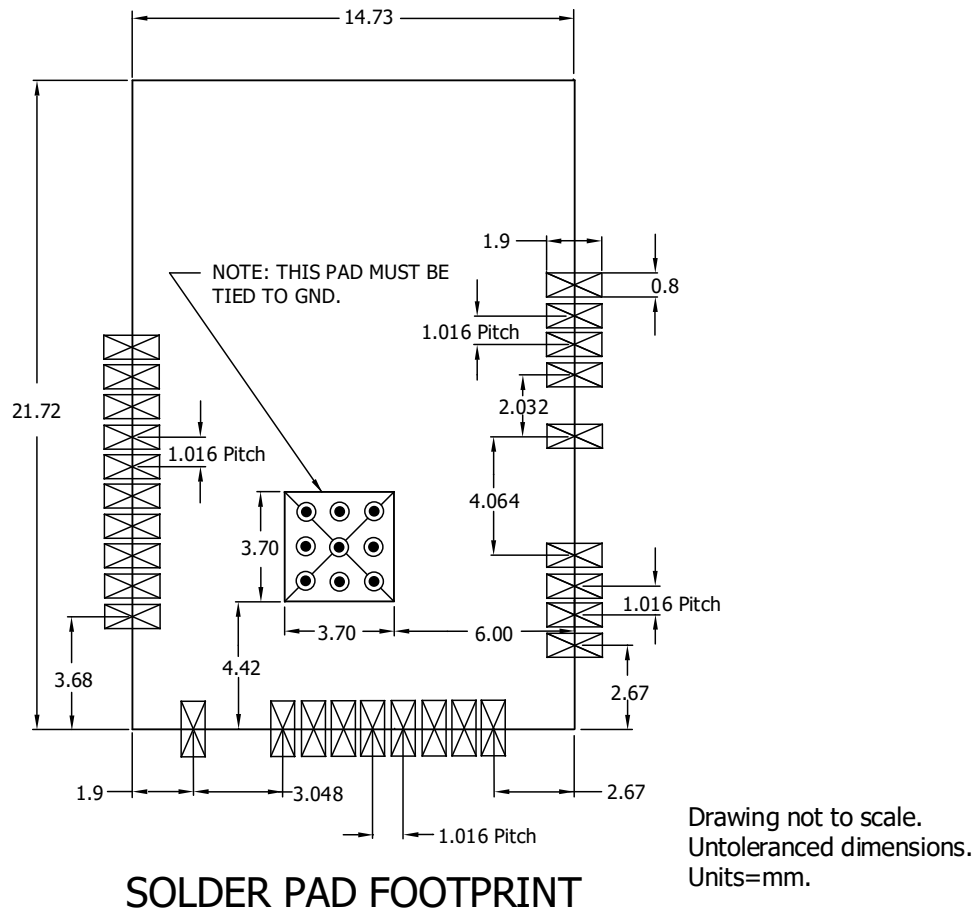

11. Design Considerations

This section provides the guidelines on placement and routing to achieve the best performance.

11.1 ATWINC15x0-MR210PB Placement and Routing Guidelines

- The module must be placed on the main board – the printed antenna area must overlap with the carrier board. The portion of the module containing the antenna must not go outside the edge of the main board. The antenna is designed to work properly when it is sitting directly on top of a 1.5 mm thick printed circuit board. The following figure shows the best, poor and worst case module placements in the host board.
- If the module is placed at the edge of the host board, a minimum 22 mm by 5 mm area directly under the antenna must be clear of all metal on all layers of the board. “In-land” placement is acceptable; however, the depth of the keep-out area must groove to: module edge to host board edge plus 5 mm.
Note: Do not place the module in the middle of the host board or far away from the host board edge.
- Follow the module placement, keepout and host PCB cutout recommendation as shown in the following figure.
 - Avoid routing any traces in the highlighted region on the top layer of the host board, which is directly below the module area.
 - Follow the electrical keep-out layer recommendation as shown in the following figure. There must not be any copper in any of the layers of the host board in this region. Avoid placing any components (like mechanical spacers, bump, etc.) in the recommended electrical keep-out area.
 - Place the GND polygon pour below the module with the recommended boundary in the top layer of the host board as shown in the following figure. There must not be any breaks in this GND plane.
 - Place sufficient GND vias in the highlighted area below the module for better RF performance.
 - It is recommended to have a 3x3 grid of GND vias solidly connecting the exposed GND paddle of the module to the inner layer ground plane. This acts as a good ground and thermal conduction for the ATWINC15x0-MR210PB module. The GND vias must have a minimum via hole size of 0.3 mm.
 - Follow the mechanical boundary of the host PCB as shown in the the following figure.
- Keep large metal objects away from the antenna to avoid electromagnetic field blocking.
- Do not enclose the antenna within a metal shield.
- Keep any components that may radiate noise or signals within the 2.4 GHz – 2.5 GHz frequency band away from the antenna and if possible, shield those components. Any noise radiated from the host board in this frequency band will degrade the sensitivity of the module.
- Make sure the width of the traces routed to GND, VDDIO and VBAT rails are sufficiently larger for handling the peak TX current consumption.

Figure 11-1. ATWINC15x0-MR210PB Placement Reference

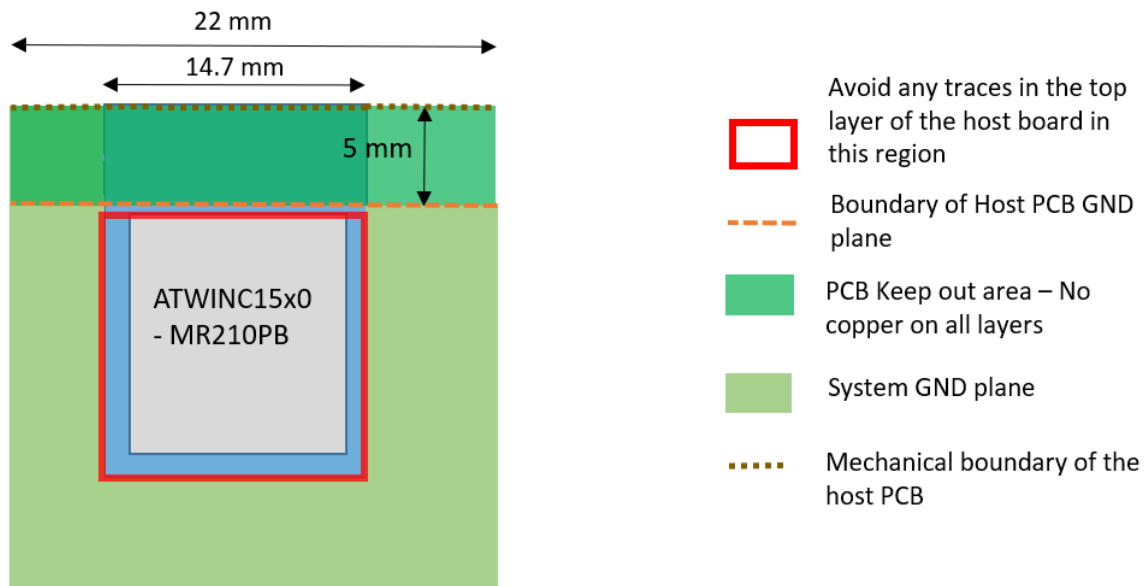
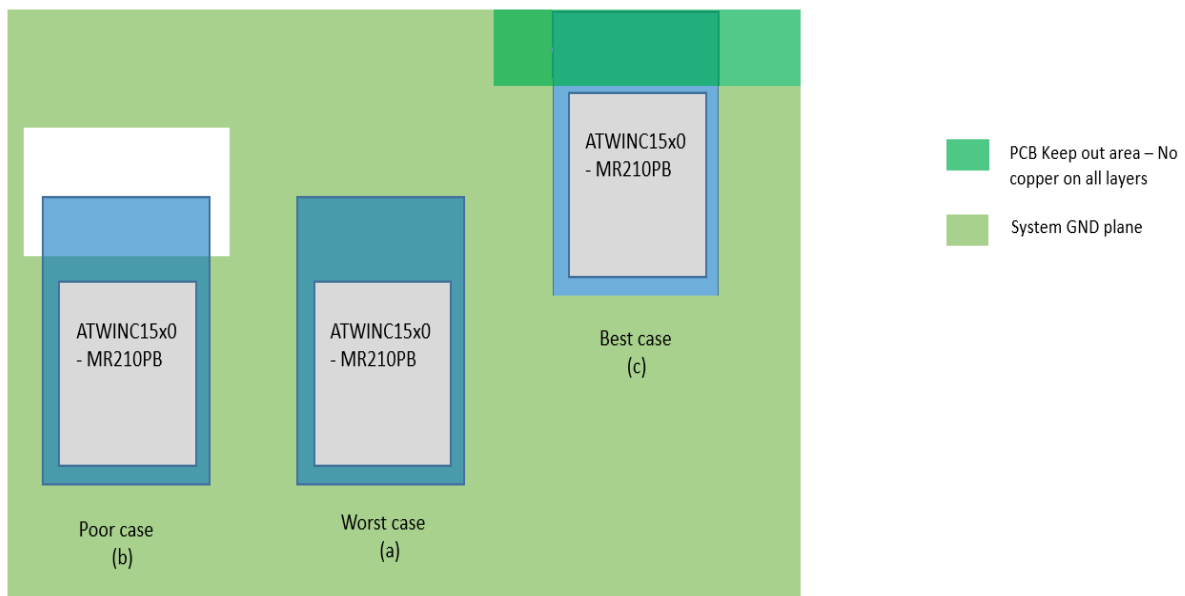

Figure 11-2. ATWINC15x0-MR210PB Placement Example



11.2 Printed PCB Antenna Performance of ATWINC15x0-MR210PB

The printed PCB antenna on the ATWINC15x0-MR210PB is a meandered Inverted F Antenna (IFA). The antenna is fed via matching network that is matched for the module installed on a 1.5 mm thick main board (FR4 substrate material). Main board thickness deviation by ± 1 mm changes RX/TX performance by ± 1 dB maximum, referring to RX/TX performance with a default antenna-matching network and installed on a 1.5 mm thick main board.

Measured peak antenna gain is -0.3 dBi.

Antenna Radiation Pattern

The following figures illustrate the Antenna Radiation Patterns.

Figure 11-3. Antenna Radiation Pattern when Phi = 0 Degree

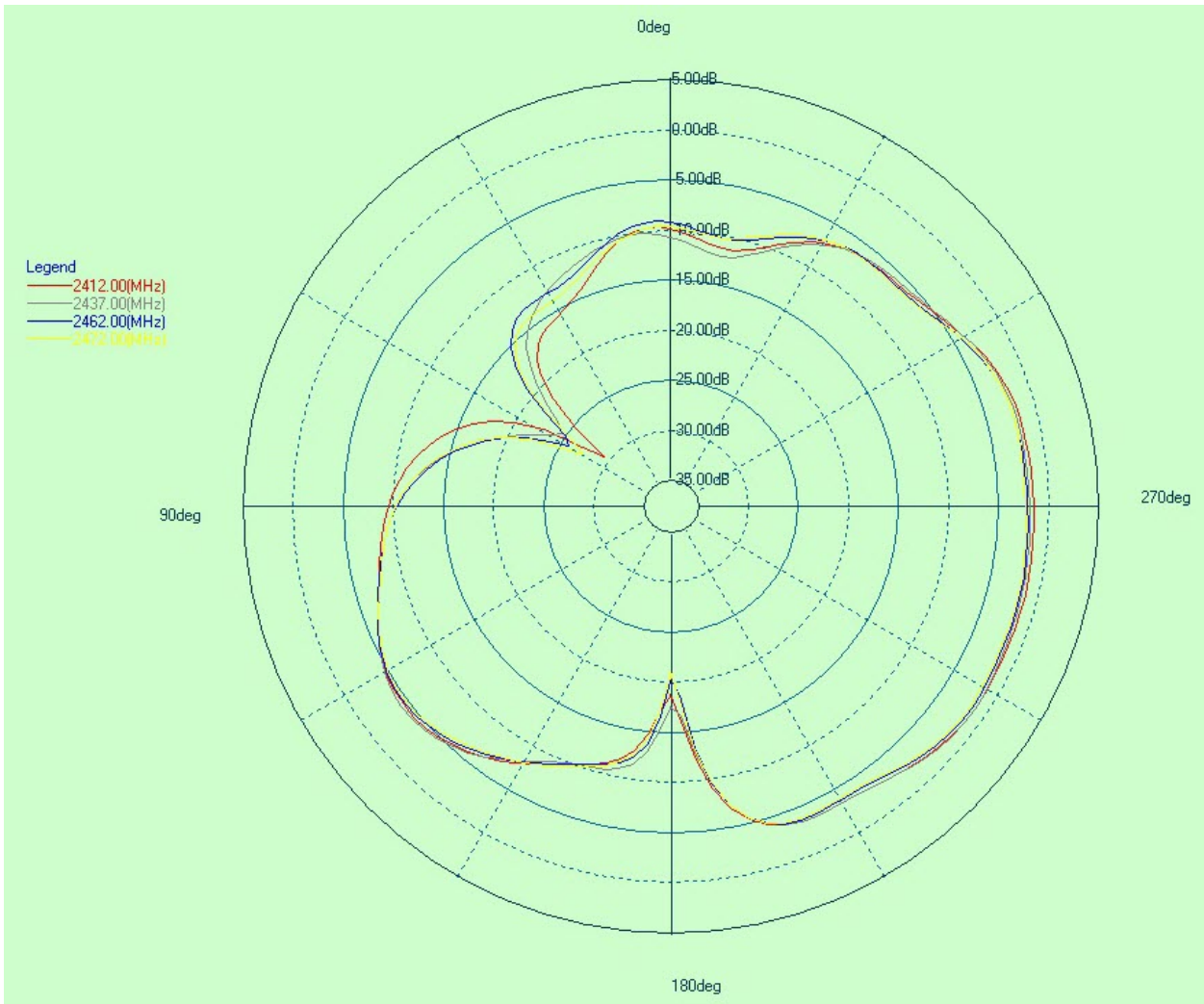

Figure 11-4. Antenna Radiation Pattern when Phi = 90 Degree

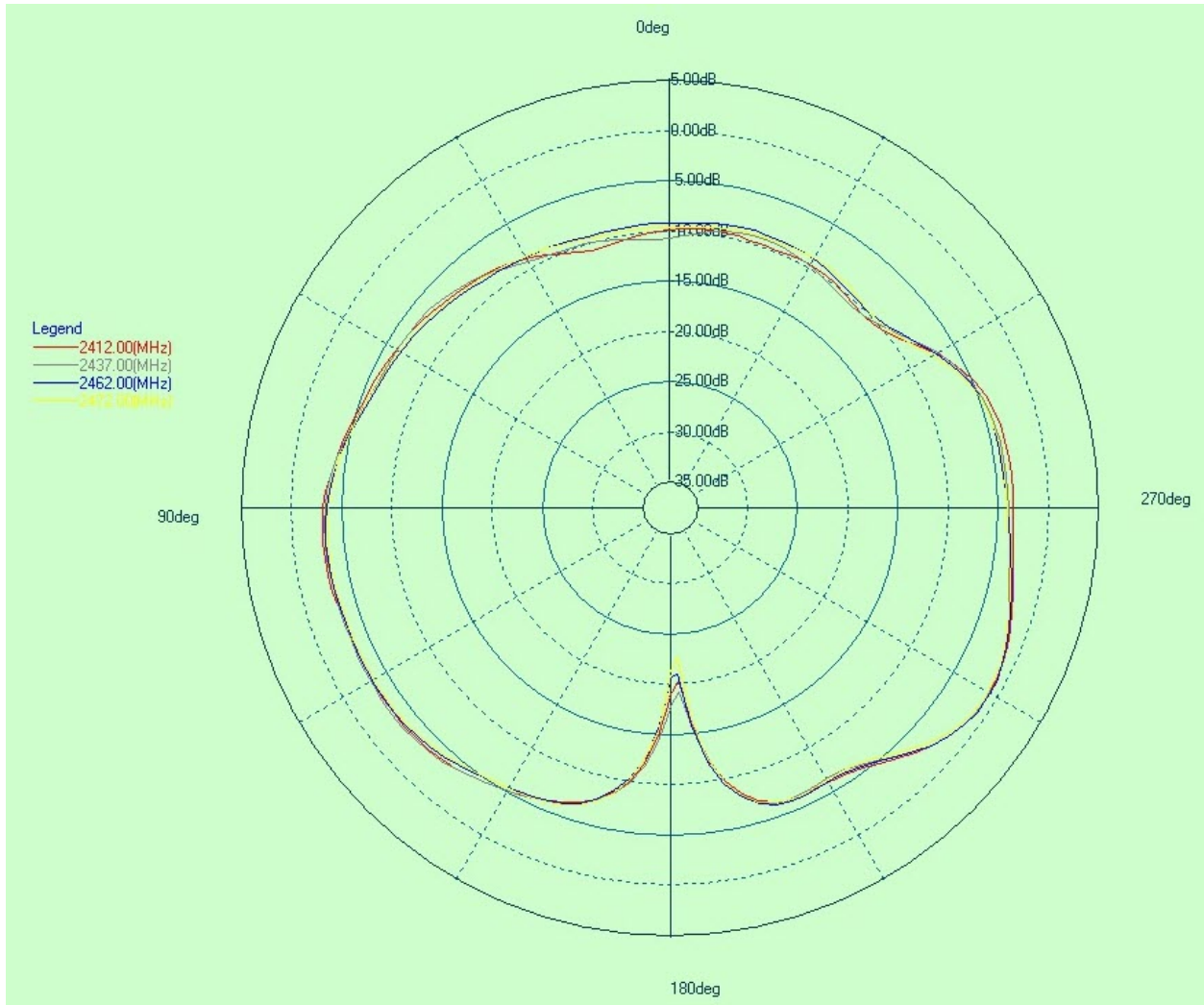
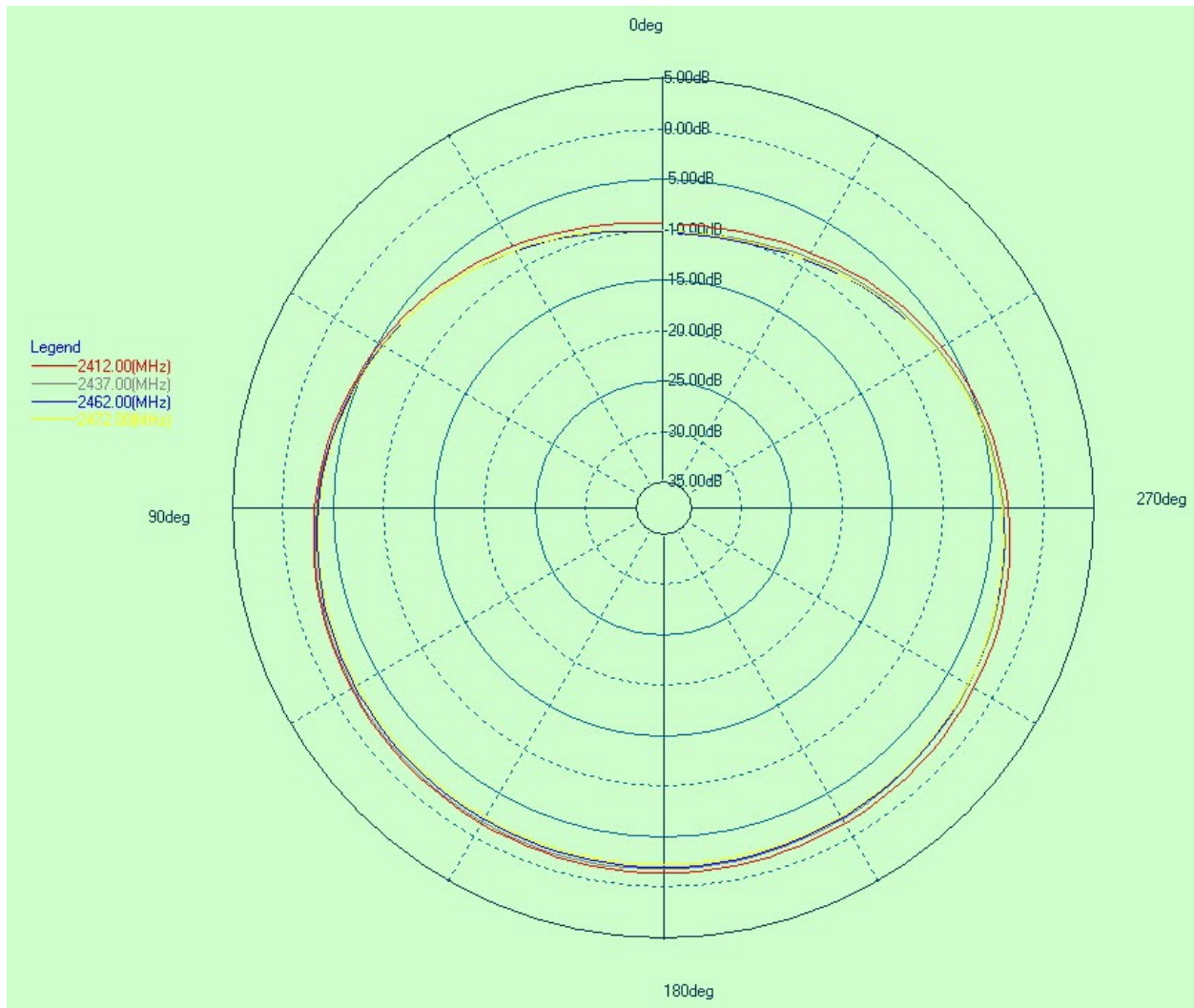

Figure 11-5. Antenna Radiation Pattern when Theta = 90 Degree



11.3 ATWINC15x0-MR210UB Placement and Routing Guidelines

The ATWINC15x0-MR210UB module has an Ultra Small Miniature RF Connector (U.FL) for the external antenna.

The choice of antenna is limited to the antenna types that the module was tested and approved for. For a list of tested and approved antennas that may be used with the module in their respective country, refer to the respective country in [Regulatory Approval](#).

It is critical to follow the recommendations listed below to achieve the best RF performance:

1. Avoid routing any traces on the top layer of the host board that is directly below the module area.
2. Place the GND polygon pour below the complete module area. There must not be any breaks in this GND plane.
3. Place sufficient GND vias in the GND polygon pour below the module area for better RF performance.
4. It is recommended to have a 3x3 grid of GND vias solidly connecting the exposed GND paddle of the module to the inner layer ground plane of the host board. This will act as a good ground and thermal conduction path for the ATWINC15x0-MR210UB module. The GND vias must have a minimum via hole size of 0.3 mm.

5. Keep large metal objects away from the external antenna to avoid electromagnetic field blocking.
6. Do not enclose the external antenna within a metal shield.
7. Keep any components that may radiate noise or signals within the 2.4 GHz – 2.5 GHz frequency band away from the external antenna and if possible, shield those components. Any noise radiated from the host board in this frequency band will degrade the sensitivity of the module.
8. Make sure the width of the traces routed to GND, VDDIO and VBAT rails are sufficiently larger for handling the peak TX current consumption.

11.4 Recommended External Antenna for ATWINC15x0-MR210UB

The ATWINC15x0-MR210UB module is approved to use with the antennas listed in the following table. It is permissible to use a different antenna, provided the same antenna type, antenna gain (equal or less than) and similar in-band and out-of-band characteristics are present (refer to the specification sheet for cutoff frequencies). If other antenna types are used, the OEM installer must conduct the necessary assessments and authorize the antenna with respective regulatory agencies and ensure compliance. Refer to the corresponding regulatory approval sections under [Regulatory Approval](#) for further guidance.

Table 11-1. ATWINC15x0-MR210UB Approved External Antenna Table with Antenna Gain^(1, 2, 3)

List Item	Part Number	Manufacturer	Antenna Gain at 2.4 GHz band	Antenna type	ATWINC15x0-MR210UB	
					FCC/ISED	CE
1	RFA-02-P33	Aristotle	2	PCB	X	X
2	RFA-02-D3	Aristotle	2	Dipole	X	X
3	RFA-02-G03	Aristotle	2	Metal Stamp	X	X
4	RFA-02-L2H1	Aristotle	2	Dipole	X	X
5	RFA-02-P05	Aristotle	2	PCB	X	X
6	RFA-02-C2M2	Aristotle	2	Dipole	X	X
7	86254	Delock	2	PCB	—	X
8	W3525B039	Pulse Electronics	2	PCB	X	X
9	RFDP A870920IM LB301	WALSIN	1.84	Dipole	X	X
10	RN-SMA-S	Microchip	0.56	Dipole	X	X

Notes:

1. X = Antennas covered under the certification
2. If the end product using the Module is designed to have an antenna port that is accessible to the end user, RP (Reverse Polarity)-SMA socket must be used.
3. If an RF coaxial cable is used between the module RF output and the enclosure, an RP-SMA connector must be used in the enclosure wall for interface with the antenna.
4. Contact the antenna vendor for detailed antenna specifications to review the suitability to the end-product operating environment and to identify alternatives.

11.4.1 Antenna Placement Recommendations for ATWINC15x0-MR210UB

The following recommendations must be applied for the placement of the antenna and its cable:

- The antenna cable must not be routed over circuits generating electrical noise on the host board or alongside or underneath the module. It is preferred that the cable be routed straight out of the module.

- The antenna must not be placed in direct contact or in close proximity of the plastic casing/ objects.
- Do not enclose the antenna within a metal shield.
- Keep any components which may radiate noise, signals or harmonics within the 2.4 GHz to 2.5 GHz frequency band away from the antenna and, if possible, shield those components. Any noise radiated from the host board in this frequency band degrades the sensitivity of the module.
- The antenna should preferably be placed at a distance greater than 5 cm away from the module. The following figure shows the antenna keep-out area indication; where the antenna must not be placed in this area. This recommendation is based on an open-air measurement and does not take into account any metal shielding of the customer end product. When a metal enclosure is used, the antenna can be located closer to the ATWINC15x0-MR210UB module.

The drawing below provides an indication of how the antenna cable should be routed depending on the location of the antenna with respect to the ATWINC15x0-MR210UB PCB. There are two possible options for the optimum routing of the cable.

Figure 11-6. ATWINC15x0-MR210UB Antenna Placement Guidelines

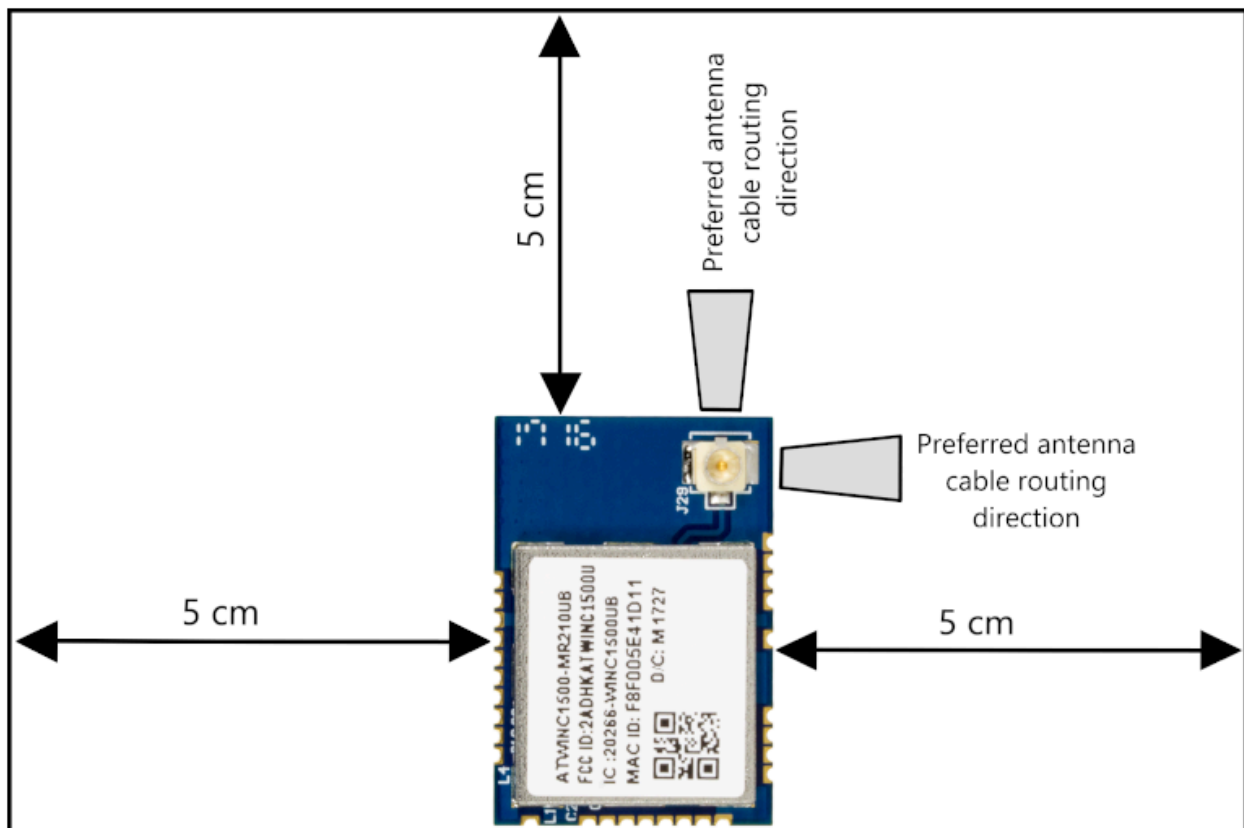

Note: These are generic guidelines and it is recommended that customers check and fine-tune the antenna positioning in the final host product based on RF performance.

11.5 Module Assembly Considerations

The ATWINC15x0-MR210xB modules are assembled with an EMI Shield to ensure compliance with EMI emission and immunity rules. The EMI shield is made of a tin-plated steel (SPTE) and is not hermetically sealed. Solutions like IPA and similar solvents can be used to clean the ATWINC15x0-MR210xB module. However, cleaning solutions that contain acid must never be used on the module.

11.6 Conformal Coating

The modules are not intended for use with a conformal coating and the customer assumes all risks (such as the module reliability, performance degradation and so on) if a conformal coating is applied to the modules.

11.7 Reflow Profile Information

For information on the reflow process guidelines, refer to the “Solder Reflow Recommendation” Application Note ([AN233](#)).

12. Regulatory Approval

The ATWINC15x0-MR210xB module has received regulatory approval from the following countries:

- ATWINC1500-MR210PB
 - United States/FCC ID: 2ADHKATWINC1500
 - Canada
 - IC ID: 20266-WINC1500PB
 - HVIN: ATWINC1500-MR210PB
 - PMN: ATWINC1500-MR210PB
 - Europe: CE
 - Japan/MIC: 005-101762
 - Korea/KCC: R-CRM-mcp-WINC1510MR210P
 - Taiwan/NCC: CCAN18LP0321T2
 - China/SRRC: CMIIT ID: 2018DJ1305
 - ANATEL: 08497-18-08759
- ATWINC1510-MR210PB
 - United States/FCC ID: 2ADHKATWINC1510
 - Canada
 - IC ID: 20266-ATWINC1510
 - HVIN: ATWINC1510-MR210PB
 - PMN: ATWINC1510-MR210PB
 - Europe: CE
 - Japan/MIC: 005-101762
 - Korea/KCC: R-CRM-mcp-WINC1510MR210P
 - Taiwan/NCC: CCAN18LP0320T0
 - China/SRRC: CMIIT ID: 2018DJ1310
 - ANATEL: 08497-18-08759
- ATWINC1500-MR210UB
 - United States/FCC ID: 2ADHKATWINC1500U
 - Canada
 - IC ID: 20266-WINC1500UB
 - HVIN: ATWINC1500-MR210UB
 - PMN: ATWINC1500-MR210UB
 - Europe: CE
 - ANATEL: 08497-18-08759
- ATWINC1510-MR210UB
 - United States/FCC ID: 2ADHKATWINC1500U
 - Canada
 - IC: 20266-WINC1500UB
 - HVIN: ATWINC1510-MR210UB
 - PMN: ATWINC1510-MR210UB

- Europe: CE
- ANATEL: 08497-18-08759

Gain Table for Individual Regulatory Region

The default firmware uses a common gain table that meets IEEE 802.11 specifications and regulatory regions (ATWINC15x0-MR210PB – United States/FCC, Canada/ISED, Europe/CE, Japan/MIC, Korea/KCC, Taiwan/NCC and China/SRRC; ATWINC15x0-MR210UB – United States/FCC, Canada/ISED and Europe/CE). In some cases, the output power is limited by the regulatory region with the most stringent transmit power limits. If the end product's destination is known, the region-specific gain table can optionally be embedded into the firmware to optimize performance.

The application gain table for individual regulatory region is available on ATWINC15x0-MR210PB and ATWINC15x0-MR210UB product page. Customers can update the gain table in firmware by following the instructions in section 6. Updating Application Gain Table into ATWINC15x0 of ATWINC15x0 – *Deriving Application Gain Table Application Note*.

Note: The users in Brazil must ensure that application gain table for Brazil is embedded into the firmware. The application gain table for Brazil/ANATEL is available on ATWINC15x0-MR210PB product page.

12.1 United States

The ATWINC1500-MR210PB, ATWINC1510-MR210PB, ATWINC1500-MR210UB and ATWINC1510-MR210UB modules have received Federal Communications Commission (FCC) CFR47 Telecommunications, Part 15 Subpart C “Intentional Radiators” single-modular approval in accordance with Part 15.212 Modular Transmitter approval. Single-modular transmitter approval is defined as a complete RF transmission sub-assembly, designed to be incorporated into another device, that must demonstrate compliance with FCC rules and policies independent of any host. A transmitter with a modular grant can be installed in different end-use products (referred to as a host, host product or host device) by the grantee or other equipment manufacturer, then the host product may not require additional testing or equipment authorization for the transmitter function provided by that specific module or limited module device.

The user must comply with all of the instructions provided by the Grantee, which indicate installation and/or operating conditions necessary for compliance.

A host product itself is required to comply with all other applicable FCC equipment authorization regulations, requirements, and equipment functions that are not associated with the transmitter module portion. For example, compliance must be demonstrated: to regulations for other transmitter components within a host product; to requirements for unintentional radiators (Part 15 Subpart B), such as digital devices, computer peripherals, radio receivers, etc.; and to additional authorization requirements for the non-transmitter functions on the transmitter module (i.e., Suppliers Declaration of Conformity (SDoC) or certification) as appropriate (e.g., Bluetooth and Wi-Fi transmitter modules may also contain digital logic functions).

12.1.1 Labeling and User Information Requirements

The ATWINC1500-MR210PB, ATWINC1510-MR210PB, ATWINC1500-MR210UB and ATWINC1510-MR210UB modules have been labeled with its own FCC ID number, and if the FCC ID is not visible when the module is installed inside another device, then the outside of the finished product into which the module is installed must display a label referring to the enclosed module. This exterior label must use the following wording:

- For ATWINC1500-MR210PB:

<p>Contains Transmitter Module FCC ID: 2ADHKATWINC1500 or Contains FCC ID: 2ADHKATWINC1500 This device complies with Part 15 of the FCC Rules. Operation is subject to the following two conditions: (1) this device may not cause harmful interference, and (2) this device must accept any interference received, including interference that may cause undesired operation.</p>
<ul style="list-style-type: none"> • For ATWINC1510-MR210PB
<p>Contains Transmitter Module FCC ID: 2ADHKATWINC1510 or Contains FCC ID: 2ADHKATWINC1510 This device complies with Part 15 of the FCC Rules. Operation is subject to the following two conditions: (1) this device may not cause harmful interference, and (2) this device must accept any interference received, including interference that may cause undesired operation.</p>
<ul style="list-style-type: none"> • For ATWINC1500-MR210UB
<p>Contains Transmitter Module FCC ID: 2ADHKATWINC1500U or Contains FCC ID: 2ADHKATWINC1500U This device complies with Part 15 of the FCC Rules. Operation is subject to the following two conditions: (1) this device may not cause harmful interference, and (2) this device must accept any interference received, including interference that may cause undesired operation.</p>
<ul style="list-style-type: none"> • For ATWINC1510-MR210UB
<p>Contains Transmitter Module FCC ID: 2ADHKATWINC1500U or Contains FCC ID: 2ADHKATWINC1500U This device complies with Part 15 of the FCC Rules. Operation is subject to the following two conditions: (1) this device may not cause harmful interference, and (2) this device must accept any interference received, including interference that may cause undesired operation.</p>

The user's manual for the finished product must include the following statement:

<p>This equipment has been tested and found to comply with the limits for a Class B digital device, pursuant to part 15 of the FCC Rules. These limits are designed to provide reasonable protection against harmful interference in a residential installation. This equipment generates, uses and can radiate radio frequency energy, and if not installed and used in accordance with the instructions, may cause harmful interference to radio communications. However, there is no guarantee that interference will not occur in a particular installation. If this equipment does cause harmful interference to radio or television reception, which can be determined by turning the equipment off and on, the user is encouraged to try to correct the interference by one or more of the following measures:</p> <ul style="list-style-type: none"> • Reorient or relocate the receiving antenna • Increase the separation between the equipment and receiver • Connect the equipment into an outlet on a circuit different from that to which the receiver is connected • Consult the dealer or an experienced radio/TV technician for help

Additional information on labeling and user information requirements for Part 15 devices can be found in KDB Publication 784748, which is available at the FCC Office of Engineering and Technology (OET) Laboratory Division Knowledge Database (KDB) apps.fcc.gov/oetcf/kdb/index.cfm.

12.1.2 RF Exposure

All transmitters regulated by FCC must comply with RF exposure requirements. KDB 447498 General RF Exposure Guidance provides guidance in determining whether proposed or existing transmitting facilities, operations or devices comply with limits for human exposure to Radio Frequency (RF) fields adopted by the Federal Communications Commission (FCC).

From the FCC Grant: Output power listed is conducted. This transmitter is restricted for use with the specific antenna(s) tested in this application for Certification.

The antenna(s) used with this transmitter must be installed to provide a separation distance of at least 6.5 cm from all persons and must not be co-located or operating in conjunction with any other antenna or transmitter. Users and installers must be provided with antenna installation instructions and transmitter operating conditions for satisfying RF exposure compliance.

12.1.3 Approved Antenna Types

To maintain modular approval in the United States, only the antenna types that have been tested shall be used. It is permissible to use different antenna provided the same antenna type and antenna gain (equal to or less than) is used. An antenna type comprises antennas having similar in-band and out-of-band radiation patterns.

For the ATWINC15x0-MR210PB, the approval is received using the integral PCB antenna.

For the ATWINC15x0-MR210UB, approved antennas are listed in the [Recommended External Antenna for ATWINC15x0-MR210UB](#).

12.1.4 Helpful Web Sites

- Federal Communications Commission (FCC): www.fcc.gov.
- FCC Office of Engineering and Technology (OET) Laboratory Division Knowledge Database (KDB) apps.fcc.gov/oetcf/kdb/index.cfm.

12.2 Canada

The ATWINC1500-MR210PB, ATWINC1510-MR210PB, ATWINC1500-MR210UB and ATWINC1510-MR210UB modules have been certified for use in Canada under Innovation, Science and Economic Development Canada (ISED, formerly Industry Canada) Radio Standards Procedure (RSP) RSP-100, Radio Standards Specification (RSS) RSS-Gen and RSS-247. Modular approval permits the installation of a module in a host device without the need to recertify the device.

12.2.1 Labeling and User Information Requirements

Labeling Requirements (from RSP-100 - Issue 12, Section 5): The host product shall be properly labeled to identify the module within the host device.

The Innovation, Science and Economic Development Canada certification label of a module shall be clearly visible at all times when installed in the host device; otherwise, the host product must be labeled to display the Innovation, Science and Economic Development Canada certification number of the module, preceded by the word "Contains" or similar wording expressing the same meaning, as follows:

• For ATWINC1500-MR210PB
Contains IC: 20266-WINC1500PB
• For ATWINC1510-MR210PB
Contains IC: 20266-ATWINC1510
• For ATWINC1500-MR210UB
Contains IC: 20266-WINC1500UB

- For ATWINC1510-MR210UB

Contains IC: 20266-WINC1500UB

User Manual Notice for License-Exempt Radio Apparatus (from Section 8.4 RSS-Gen, Issue 5, March 2019): User manuals for license-exempt radio apparatus shall contain the following or equivalent notice in a conspicuous location in the user manual or alternatively on the device or both:

This device contains license-exempt transmitter(s)/receiver(s) that comply with Innovation, Science and Economic Development Canada's license-exempt RSS(s). Operation is subject to the following two conditions:

- (1) This device may not cause interference;**
- (2) This device must accept any interference, including interference that may cause undesired operation of the device.**

L'émetteur/récepteur exempt de licence contenu dans le présent appareil est conforme aux CNR d'Innovation, Sciences et Développement économique Canada applicables aux appareils radio exempts de licence. L'exploitation est autorisée aux deux conditions suivantes:

- 1. L'appareil ne doit pas produire de brouillage;**
- 2. L'appareil doit accepter tout brouillage radioélectrique subi, même si le brouillage est susceptible d'en compromettre le fonctionnement.**

Transmitter Antenna (From Section 6.8 RSS-GEN, Issue 5, March 2019): User manuals, for transmitters shall display the following notice in a conspicuous location:

This radio transmitter [IC: 20266-WINC1500PB, IC: 20266-ATWINC1510, IC: 20266-WINC1500UB and IC: 20266-WINC1500UB] has been approved by Innovation, Science and Economic Development Canada to operate with the antenna types listed below, with the maximum permissible gain indicated. Antenna types not included in this list that have a gain greater than the maximum gain indicated for any type listed are strictly prohibited for use with this device.

Le présent émetteur radio [IC: 20266-WINC1500PB, IC: 20266-ATWINC1510, IC: 20266-WINC1500UB and IC: 20266-WINC1500UB] a été approuvé par Innovation, Sciences et Développement économique Canada pour fonctionner avec les types d'antenne énumérés cidessous et ayant un gain admissible maximal. Les types d'antenne non inclus dans cette liste, et dont le gain est supérieur au gain maximal indiqué pour tout type figurant sur la liste, sont strictement interdits pour l'exploitation de l'émetteur.

Immediately following the above notice, the manufacturer shall provide a list of all antenna types approved for use with the transmitter, indicating the maximum permissible antenna gain (in dBi) and required impedance for each.

12.2.2 RF Exposure

All transmitters regulated by Innovation, Science and Economic Development Canada (ISED) must comply with RF exposure requirements listed in RSS-102 - Radio Frequency (RF) Exposure Compliance of Radio communication Apparatus (All Frequency Bands).

This transmitter is restricted for use with a specific antenna tested in this application for certification, and must not be co-located or operating in conjunction with any other antenna or transmitters within a host device, except in accordance with Canada multi-transmitter product procedures.

The installation of the transmitter must ensure that the antenna has a separation distance of at least 6.5 cm from all persons or compliance must be demonstrated according to the ISED SAR procedures.

12.2.3 Approved Antenna Types

For the ATWINC15x0-MR210PB, the approval is received using the integral PCB antenna.

For the ATWINC15x0-MR210UB, approved antennas are listed in the [Recommended External Antenna for ATWINC15x0-MR210UB](#).

12.2.4 Helpful Web Sites

Innovation, Science and Economic Development Canada (ISED): www.ic.gc.ca/.

12.3 Europe

The ATWINC1500-MR210PB, ATWINC1510-MR210PB, ATWINC1500-MR210UB and ATWINC1510-MR210UB modules is/are a Radio Equipment Directive (RED) assessed radio module that is CE marked and has been manufactured and tested with the intention of being integrated into a final product.

The ATWINC1500-MR210PB, ATWINC1510-MR210PB, ATWINC1500-MR210UB and ATWINC1510-MR210UB modules has/have been tested to RED 2014/53/EU Essential Requirements mentioned in the following European Compliance table.

Table 12-1. European Compliance

Certification	Standards	Article
Safety	EN 62368	3.1a
Health	EN 62311	
EMC	EN 301 489-1	3.1b
	EN 301 489-17	
Radio	EN 300 328	3.2

The ETSI provides guidance on modular devices in the *"Guide to the application of harmonised standards covering articles 3.1b and 3.2 of the RED 2014/53/EU (RED) to multi-radio and combined radio and non-radio equipment"* document available at http://www.etsi.org/deliver/etsi_eg/203300_203399/20_3367/01.01.01_60/eg_203367v010101p.pdf.

Note: To maintain conformance to the standards listed in the preceding European Compliance table, the module shall be installed in accordance with the installation instructions in this data sheet and shall not be modified. When integrating a radio module into a completed product, the integrator becomes the manufacturer of the final product and is therefore responsible for demonstrating compliance of the final product with the essential requirements against the RED.

12.3.1 Labeling and User Information Requirements

The label on the final product that contains the ATWINC1500-MR210PB, ATWINC1510-MR210PB, ATWINC1500-MR210UB and ATWINC1510-MR210UB modules must follow CE marking requirements.

12.3.2 Conformity Assessment

From ETSI Guidance Note EG 203367, section 6.1, when non-radio products are combined with a radio product:

If the manufacturer of the combined equipment installs the radio product in a host non-radio product in equivalent assessment conditions (i.e. host equivalent to the one used for the assessment of the radio product) and according to the installation instructions for the radio product, then no additional assessment of the combined equipment against article 3.2 of the RED is required.

12.3.2.1 Simplified EU Declaration of Conformity

Hereby, Microchip Technology Inc. declares that the radio equipment type ATWINC1500-MR210PB, ATWINC1510-MR210PB, ATWINC1500-MR210UB and ATWINC1510-MR210UB modules is/are in compliance with Directive 2014/53/EU.

The full text of the EU declaration of conformity for this product is available at <http://www.microchip.com/ATWINC1500> (available under Documents > Certifications).

12.3.3 Approved Antenna Types

For the ATWINC15x0-MR210PB, the approval is received using the integral PCB antenna.

For the ATWINC15x0-MR210UB, approved antennas are listed in the [Recommended External Antenna for ATWINC15x0-MR210UB](#).

12.3.4 Helpful Websites

A document that can be used as a starting point in understanding the use of Short Range Devices (SRD) in Europe is the European Radio Communications Committee (ERC) Recommendation 70-03 E, which can be downloaded from the European Communications Committee (ECC) at: <http://www.ecodocdb.dk/>.

Additional helpful web sites are:

- Radio Equipment Directive (2014/53/EU):
https://ec.europa.eu/growth/single-market/european-standards/harmonised-standards/red_en
- European Conference of Postal and Telecommunications Administrations (CEPT):
<http://www.cept.org>
- European Telecommunications Standards Institute (ETSI):
<http://www.etsi.org>
- The Radio Equipment Directive Compliance Association (REDCA):
<http://www.redca.eu/>

12.4 Japan

The ATWINC1500-MR210PB and ATWINC1510-MR210PB modules has/have received type certification and is required to be labeled with its own technical conformity mark and certification number as required to conform to the technical standards regulated by the Ministry of Internal Affairs and Communications (MIC) of Japan pursuant to the Radio Act of Japan.

Integration of this module into a final product does not require additional radio certification provided installation instructions are followed and no modifications of the module are allowed. Additional testing may be required:

- If the host product is subject to electrical appliance safety (for example, powered from an AC mains), the host product may require Product Safety Electrical Appliance and Material (PSE) testing. The integrator should contact their conformance laboratory to determine if this testing is required
- There is an voluntary Electromagnetic Compatibility (EMC) test for the host product administered by VCCI: www.vcci.jp/vcci_e/index.html

12.4.1 Labeling and User Information Requirements

The label on the final product which contains the ATWINC1500-MR210PB and ATWINC1510-MR210PB modules must follow Japan marking requirements. The integrator of the module should refer to the labeling requirements for Japan available at the Ministry of Internal Affairs and Communications (MIC) website.

For the ATWINC1500-MR210PB and ATWINC1510-MR210PB module/s, due to a limited module size, the technical conformity logo and ID is displayed in the data sheet and/or packaging and cannot be displayed on the module label. The final product in which this module is being used must have a label referring to the type certified module inside:



12.4.2 Helpful Web Sites

- Ministry of Internal Affairs and Communications (MIC): www.tele.soumu.go.jp/e/index.htm.
- Association of Radio Industries and Businesses (ARIB): www.arib.or.jp/english/.

12.5 Korea

The ATWINC1500-MR210PB and ATWINC1510-MR210PB modules has/have received certification of conformity in accordance with the Radio Waves Act. Integration of this module into a final product does not require additional radio certification provided installation instructions are followed and no modifications of the module are allowed.

12.5.1 Labeling and User Information Requirements

The label on the final product which contains the ATWINC1500-MR210PB and ATWINC1510-MR210PB modules must follow KC marking requirements. The integrator of the module should refer to the labeling requirements for Korea available on the Korea Communications Commission (KCC) website.

For ATWINC1500-MR210PB and ATWINC1510-MR210PB module/s, due to a limited module size, the KC mark and ID are displayed in the data sheet and/or packaging and cannot be displayed on the module label. The final product requires the KC mark and certificate number of the module:



12.5.2 Helpful Websites

- Korea Communications Commission (KCC): www.kcc.go.kr.
- National Radio Research Agency (RRA): rra.go.kr.

12.6 Taiwan

The ATWINC1500-MR210PB and ATWINC1510-MR210PB modules has/have received compliance approval in accordance with the Telecommunications Act. Customers seeking to use the compliance approval in their product should contact Microchip Technology sales or distribution partners to obtain a Letter of Authority.

Integration of this module into a final product does not require additional radio certification provided installation instructions are followed and no modifications of the module are allowed.

12.6.1 Labeling and User Information Requirements

For the ATWINC1500-MR210PB module, due to the limited module size, the NCC mark and ID are displayed in the data sheet only and cannot be displayed on the module label:

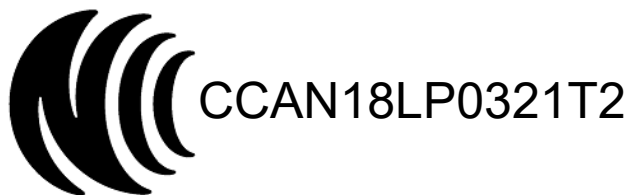

For the ATWINC1510-MR210PB module, due to the limited module size, the NCC mark and ID are displayed in the data sheet only and cannot be displayed on the module label:

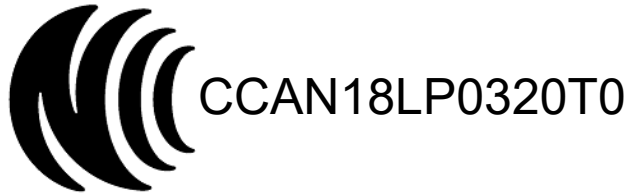

The user's manual should contain following warning (for RF device) in traditional Chinese:

根據 NCC LP0002 低功率射頻器材技術規範_章節 3.8.2:

取得審驗證明之低功率射頻器材，非經核准，公司、商號或使用者均不得擅自變更頻率、加大功率或變更原設計之特性及功能。

低功率射頻器材之使用不得影響飛航安全及干擾合法通信；經發現有干擾現象時，應立即停用，並改善至無干擾時方得繼續使用。

前述合法通信，指依電信管理法規定作業之無線電通信。

低功率射頻器材須忍受合法通信或工業、科學及醫療用電波輻射性電機設備之干擾。

12.6.2 Helpful Web Sites

National Communications Commission (NCC): www.ncc.gov.tw

12.7 China

The ATWINC1500-MR210PB and ATWINC1510-MR210PB modules has/have received certification of conformity in accordance with the China MIIT Notice 2014-01 of State Radio Regulation Committee (SRRC) certification scheme. Integration of this module into a final product does not require additional radio certification, provided installation instructions are followed and no modifications of the module are allowed. Refer to SRRC certificate available in ATWINC15x0-MR210xB product page for expiry date.

12.7.1 Labeling and User Information Requirements

The ATWINC1500-MR210PB module is labeled with its own CMIIT ID as follows:

CMIIT ID: 2018DJ1305

The ATWINC1500-MR210PB module is labeled with its own CMIIT ID as follows:

CMIIT ID: 2018DJ1310

When Host system is using an approved Full Modular Approval (FMA) radio: The host must bear a label containing the statement "This device contains SRRC approved Radio module CMIIT ID: 2018DJ2733".

12.8 Brazil

The ATWINC1500-MR210PB, ATWINC1510-MR210PB, ATWINC1500-MR210UB and ATWINC1510-MR210UB modules has/have received compliance approval in accordance with the Telecommunications Act of the Federal Republic of Brazil National Telecommunications Agency (ANATEL). Customers seeking to use the compliance approval in their product must contact Microchip Technology Inc. sales or distribution partners to obtain a Letter of Authority.

Modelo: ATWINC1500-MR210PB



08497-18-08759

Este equipamento opera em caráter secundário, isto é, não tem direito a proteção contra interferência prejudicial, mesmo de estações do mesmo tipo, e não pode causar interferência a sistemas operando em caráter primário

The End product (Host) manual must include the following statement:

Este product contém a placa Modelo ATWINC1500-MR210PB código de homologação ANATEL08497-18-08759.

Modelo: ATWINC1510-MR210PB



08497-18-08759

Este equipamento opera em caráter secundário, isto é, não tem direito a proteção contra interferência prejudicial, mesmo de estações do mesmo tipo, e não pode causar interferência a sistemas operando em caráter primário

The End product (Host) manual must include the following statement:

Este product contém a placa Modelo ATWINC1510-MR210PB código de homologação ANATEL 08497-18-08759.

Modelo: ATWINC1500-MR210UB



08497-18-08759

Este equipamento opera em caráter secundário, isto é, não tem direito a proteção contra interferência prejudicial, mesmo de estações do mesmo tipo, e não pode causar interferência a sistemas operando em caráter primário

The End product (Host) manual must include the following statement:

Este product contém a placa Modelo ATWINC1500-MR210UB código de homologação ANATEL 08497-18-08759.

Modelo: ATWINC1510-MR210UB



08497-18-08759

Este equipamento opera em caráter secundário, isto é, não tem direito a proteção contra interferência prejudicial, mesmo de estações do mesmo tipo, e não pode causar interferência a sistemas operando em caráter primário

The End product (Host) manual must include the following statement:

Este product contém a placa Modelo ATWINC1510-MR210UB código de homologação ANATEL 08497-18-08759.

12.8.1 Helpful Web Sites

- ANATEL: www.anatel.gov.br.

12.9 Other Regulatory Information

- For information about other countries' jurisdictions not covered here, refer to www.microchip.com/ATWINC1500 (available under Documents > Certifications).
- If the customer needs another regulatory jurisdiction certification or to recertify the module for other reasons, contact Microchip for the required utilities and documentation.

13. Reference Documentation and Support

13.1 Reference Documentation

The following table provides the set of collateral documents to ease integration and device ramp.

Table 13-1. Reference Documents

Title	Content
ATWINC15x0B-MU SoC Data Sheet	Data sheet for the ATWINC15x0 SmartConnect Wi-Fi component. For more details, contact a Microchip sales representative.
Platform Getting Started Guide	Details on how to evaluate the WINC15X0 Network Controller Module.
Flash Memory Download Procedure	Details the download procedures of firmware, root certificate, gain table values, etc.
ATWINC1500 Wi-Fi Network Controller Software Design Guide	Integration guide with a clear description of High-level Arch, an overview on how to write a networking application, list all APIs, parameters and structures. Features of the device, SPI/handshake protocol between device and host MCU, with flow/sequence/state diagram and timing.
Software Programming Guide (ATWINC15x0)	Details the flow chart and how to use each API to implement all generic use cases (for example, start AP, start STA, provisioning, UDP, TCP, HTTP, TLS, p2p, errors management, connection/recovery mechanism/state diagram) – usage and sample application note.
ATWINC15x0B/ATWINC15x0 – MR210xB Errata	This document provides details on the anomalies identified in the ATWINC15x0 family of devices.
ATWINC15x0 – Deriving Application Gain Table Application Note (available in the ATWINC15x0B Reference Design Package on ATWINC1500-IC webpage under Supporting Collateral)	This application note describes the Wi-Fi gain table structure and procedure to derive the application gain table. This document contains further details on the steps to update the device with the gain table.
MCHPRT2 User guide	This document provides detailed information about the MCHPRT2 tool, which allows the user to easily configure, evaluate and test an RF system.

Note: A Design Files Package is available under NDA. For more details, contact a Microchip sales representative.

For a complete list of development-support tools and documentation, visit www.microchip.com or refer to the customer support section on options to locate the nearest Microchip field representative.

14. Document Revision History

Note: The data sheet revision is independent of the die revision (Revision bit in the Device Identification register of the Device Service Unit, DSU.DID.REVISION) and the device variant (last letter of the ordering number).

Revision	Date	Section	Changes
F	03/2025	Features	<ul style="list-style-type: none"> Removed Wi-Fi® Direct Added compatibility for Wi-Fi 6/7 2.4 GHz band Updated Superior MAC throughput Editorial updates
		WLAN Subsystem	Updated content
		Description	Removed HCCA
		MAC Features	<ul style="list-style-type: none"> Removed PCF, traffic scheduling Removed transmission feature in Advanced IEEE 802.11n Editorial updates.
		PHY Features	Editorial updates.
		Recommended External Antenna for ATWINC15x0-MR210UB	Removed RN-SMA-4 from Table 11-1
		Receiver Performance	Added note
		Memory Subsystem	Changed unit MB to Mb
		Application Schematic	<ul style="list-style-type: none"> Updated Figure 9-1 Updated notes
		Module Package Drawing	Updated Package drawing
E	06/2021	Document	Replaced Master/Slave with the new terminologies. For more details, see the following note.
		Europe	Updated European Compliance table
		Ordering Information and Module Marking	Updated Figure 1-1 with Tray and Tape and Reel packing information

Document Revision History (continued)			
Revision	Date	Section	Changes
D	10/2020	ATWINC15x0-MR210PB Placement and Routing Guidelines	Updated <ul style="list-style-type: none"> • Figure 11-1 • Figure 11-2
		Nonvolatile Memory (eFuse)	Updated the contents
		Interfacing with the Host Microcontroller	Updated <ul style="list-style-type: none"> • Figure 6-1 • Table 6-1
		Application Schematic	Updated Figure 9-1
		ATWINC15x0-MR210UB Placement and Routing Guidelines	Updated
		Reference Documentation	Updated Table 13-1
		Block Diagram	Updated Figure 2-1
		Pin Description	Updated Figure 2-2
		WLAN Subsystem	Added footnotes for Short GI feature
		Transmitter Performance	<ul style="list-style-type: none"> • Updated Table 3-6 • Added notes
		External Interfaces	<ul style="list-style-type: none"> • Added lead sentence • Updated the list • Updated Figure 6-1 • Updated Table 6-1
		GPIO Pins	Added Notes
		Current Consumption in Various Device States	Updated Table 7-1
		Recommended External Antenna for ATWINC15x0-MR210UB	Added
		Regulatory Approval	<ul style="list-style-type: none"> • Added Gain Table for Individual Regulatory Region section • Updated United States, Canada and Europe with the details of antennas used for approval • Revamped Europe section • Added expiry date information in China • Added regulatory note for Brazil (ANATEL) in Brazil
		Reference Documentation	Updated Table 13-1

Document Revision History (continued)			
Revision	Date	Section	Changes
C	09/2018	Features	Added Enterprise security feature and related note.
		Ordering Information and Module Marking	Updated Table 1-1
		Pin Description	Updated Table 2-1
		SPI Timing	Added note for Table 6-3
		Schematic Design Information	Editorial updates
		Module Assembly Considerations	Editorial updates
		Reflow Profile Information	<ul style="list-style-type: none"> Removed Solder Paste Removed Stencil Design Editorial updates
Regulatory Approvals	Updated the content of certifications to include the details of ATWINC1510-MR210UB module		
B	12/2017	Introduction	Editorial updates
		Features	Editorial updates
		Regulatory Approvals	Revised the content of certifications
		Reference Documents	Updated Table 15-1
A	02/2017	Document	<ul style="list-style-type: none"> Change of document style Change the name to incorporate all the ATWINC15x0-MR210xB module family New Microchip document number. Previous version was Atmel document 42502 rev. B.
		Product Description	<ul style="list-style-type: none"> Added description information indicating that the document content is relevant to all WINC1500 Module models unless noted. Changed SSL references to TLS. Removed WAPI security. Removed UART as host interface. Editorial updates.
		Product Features	<ul style="list-style-type: none"> Removed WAPI security. Removed UART and I²C as host interfaces. Removed Bluetooth coexistence interface. Replaced SSL with TLS. Added 26 MHz crystal. Removed: (4KB flash – less than 1KB RAM).
		Order Information and Module Marking	<ul style="list-style-type: none"> Revised Ordering table. Revised Marking information. Figure.

Document Revision History (continued)			
Revision	Date	Section	Changes
		Block Diagram	<ul style="list-style-type: none"> Revised Block Diagram figure.
		Pin Description	<ul style="list-style-type: none"> Revised Pin Description drawing. Editorial updates.
		Electrical Specifications	<ul style="list-style-type: none"> Revised VDDIO maximum voltage in table 4.1 and added max temperatures. Revised table 4-2 to include Recommended operating temperature.
		CPU and Memory Subsystems	<ul style="list-style-type: none"> Editorial update.
		WLAN Subsystem RADIO	<ul style="list-style-type: none"> Added text regarding performance derating at cold temperature. Features table revisions and changes: <ul style="list-style-type: none"> Corrected the package height Revised Storage temperature Added performance test conditions to the performance tables. Revised the Receive performance in table 6-2. Revised the 802.11b mode Transmit performance numbers in table 6-3. Revised Transmit performance Footnotes. Changed max frequency to 2.472GHz. Editorial updates.
		External Interfaces	<ul style="list-style-type: none"> Revised SPI timing information in table 7-3. Removed Bluetooth Coexistence section. Removed SDIO. Editorial updates.
		Power Consumption	<ul style="list-style-type: none"> Added Module Reset section for reset duration. Editorial updates.
		ATWINC15x0-MR210PB Placement and Routing Guidelines	<ul style="list-style-type: none"> Added text for antenna types used in test and an associated table. Revised Co-Ax connector type.
		Schematic Design Information	<ul style="list-style-type: none"> Removed SDIO schematic. Editorial updates.
		Module Drawings	<ul style="list-style-type: none"> Updated module drawing figures and figure titles. Added section with footprint drawing.
		Design Considerations	<ul style="list-style-type: none"> Added sections for Module design and assembly considerations and module PCB placement.
		Reflow Profile Information	<ul style="list-style-type: none"> Revised reflow profile picture to be clearer. Editorial updates.
		Certification Notices	<ul style="list-style-type: none"> Added section for Agency Certification notices (now under Regulatory Approvals with Rev. B).
		Agency Regulatory Approvals	<ul style="list-style-type: none"> Added back Agency Approval section. Revised content of certifications.
		Reference Documents	<ul style="list-style-type: none"> Moved Design File Package to a separate paragraph below the table to remove web availability aspect and to contact sales.

Note: Microchip is aware that some terminologies used in the technical documents and existing software codes of this product are outdated and unsuitable. This document may use these new terminologies, which may or may not reflect on the source codes, software GUIs and the documents referenced within this document. The following table shows the relevant terminology changes made in this document.

Table 14-1. Terminology Related Changes

Old Terminology	New Terminology	Description
Master	Host	The following sections are updated with new terminology: <ul style="list-style-type: none"> • Pin Description • SPI Timing Characteristics • Interfacing with the Host Microcontroller • SPI Client Interface • Overview • SPI Timing
Slave	Client	

(Atmel) Rev B - 02/2016

Document	<ul style="list-style-type: none"> • Updated copyright date to 2016. • Updated footers.
Module Outline Drawing	<ul style="list-style-type: none"> • Revised Module outline drawings to show Ground pad to be soldered. • Pulled out Footprint drawing as this is covered in the Module drawing.
WLAN Subsystem Radio	<ul style="list-style-type: none"> • Revised Transmit Performance Table 6-3.
Power Consumption	<ul style="list-style-type: none"> • Revised current table references in Table 8-1.
Schematic Design Information	<ul style="list-style-type: none"> • Updated Schematics Section 11 text and figures Figure 11-1 and Figure 11-2.
Reflow Profile Information	<ul style="list-style-type: none"> • Revised section 12 Reflow Profile Information.
Reference Documents	<ul style="list-style-type: none"> • Updated Document Reference table to include the ATWINC1500-MU datasheet.

(Atmel) Rev A - 07/2015

Document	Updated due to changes in the ATWINC1500 from Rev A to Rev B.
Description	<ul style="list-style-type: none"> • Updated model revisions to rev B. • Corrected Package dimensions.
Features	<ul style="list-style-type: none"> • Added Hardware Accelerator content to features list.
Pinout Information	<ul style="list-style-type: none"> • Updated reference schematic. • New pin list adds GPIO's 3,4,5 and 6.
CPU and Memory Subsystems	<ul style="list-style-type: none"> • Increased Memory from 182KB to 160KB.
External Interfaces	<ul style="list-style-type: none"> • Improved and corrected description of Coexistence interface. • Editorial updates.
Power Consumption	<ul style="list-style-type: none"> • Updated power numbers and description, added high-power and low-power modes.

WLAN Subsystem Radio

- Updated Performance numbers.

Microchip Information

Trademarks

The “Microchip” name and logo, the “M” logo, and other names, logos, and brands are registered and unregistered trademarks of Microchip Technology Incorporated or its affiliates and/or subsidiaries in the United States and/or other countries (“Microchip Trademarks”). Information regarding Microchip Trademarks can be found at <https://www.microchip.com/en-us/about/legal-information/microchip-trademarks>.

ISBN: 978-1-6683-1170-7

Legal Notice

This publication and the information herein may be used only with Microchip products, including to design, test, and integrate Microchip products with your application. Use of this information in any other manner violates these terms. Information regarding device applications is provided only for your convenience and may be superseded by updates. It is your responsibility to ensure that your application meets with your specifications. Contact your local Microchip sales office for additional support or, obtain additional support at www.microchip.com/en-us/support/design-help/client-support-services.

THIS INFORMATION IS PROVIDED BY MICROCHIP “AS IS”. MICROCHIP MAKES NO REPRESENTATIONS OR WARRANTIES OF ANY KIND WHETHER EXPRESS OR IMPLIED, WRITTEN OR ORAL, STATUTORY OR OTHERWISE, RELATED TO THE INFORMATION INCLUDING BUT NOT LIMITED TO ANY IMPLIED WARRANTIES OF NON-INFRINGEMENT, MERCHANTABILITY, AND FITNESS FOR A PARTICULAR PURPOSE, OR WARRANTIES RELATED TO ITS CONDITION, QUALITY, OR PERFORMANCE.

IN NO EVENT WILL MICROCHIP BE LIABLE FOR ANY INDIRECT, SPECIAL, PUNITIVE, INCIDENTAL, OR CONSEQUENTIAL LOSS, DAMAGE, COST, OR EXPENSE OF ANY KIND WHATSOEVER RELATED TO THE INFORMATION OR ITS USE, HOWEVER CAUSED, EVEN IF MICROCHIP HAS BEEN ADVISED OF THE POSSIBILITY OR THE DAMAGES ARE FORESEEABLE. TO THE FULLEST EXTENT ALLOWED BY LAW, MICROCHIP’S TOTAL LIABILITY ON ALL CLAIMS IN ANY WAY RELATED TO THE INFORMATION OR ITS USE WILL NOT EXCEED THE AMOUNT OF FEES, IF ANY, THAT YOU HAVE PAID DIRECTLY TO MICROCHIP FOR THE INFORMATION.

Use of Microchip devices in life support and/or safety applications is entirely at the buyer’s risk, and the buyer agrees to defend, indemnify and hold harmless Microchip from any and all damages, claims, suits, or expenses resulting from such use. No licenses are conveyed, implicitly or otherwise, under any Microchip intellectual property rights unless otherwise stated.

Microchip Devices Code Protection Feature

Note the following details of the code protection feature on Microchip products:

- Microchip products meet the specifications contained in their particular Microchip Data Sheet.
- Microchip believes that its family of products is secure when used in the intended manner, within operating specifications, and under normal conditions.
- Microchip values and aggressively protects its intellectual property rights. Attempts to breach the code protection features of Microchip products are strictly prohibited and may violate the Digital Millennium Copyright Act.
- Neither Microchip nor any other semiconductor manufacturer can guarantee the security of its code. Code protection does not mean that we are guaranteeing the product is “unbreakable”. Code protection is constantly evolving. Microchip is committed to continuously improving the code protection features of our products.